

Annual Report 2015-2017





ANNUAL REPORT 2015-2017

GREETING

A unique R&D infrastructure is the fundamental basis for a relevant R&D programme for the industry and other sectors and sustains over a long span of time. I am happy to see that ForWind managed to extend its already unique wind energy research infrastructure during the period covered by this report. The research and test campus in Hannover-Marienwerder, which includes the test centre for support structures (TTH), the large wave flume, and the 3D wave basin has been expanded by the GeCoLab, a universal motor and generator test bench, which enables in depth investigation of electrical machines and converters. It facilitates a detailed investigation on both conventional and innovative converter and generator concepts including control and filter design methods. This includes investigations into dynamics and system stability, stationary and transient thermal loading, various methods of grid feed-in and control and the response to grid faults. This new generator converter laboratory was inaugurated in 2015 and is situated inside the TTH building. It is not only adding new test capabilities to ForWind, but is also another example of how ForWind facilitates the necessary interdisciplinary research, stimulating electrical and civil engineers to research the interface problems of their respective disciplines.

Only two years later, another key research infrastructure was inaugurated, the WindLab at the Oldenburg location. This laboratory for turbulence and wind energy systems research adds a unique and badly needed wind tunnel facility to ForWind's wind tunnel portfolio. A 30 m long measurement section, high wind speeds and especially the impressive self-developed active grid not only allow to reproduce realistically scaled atmospheric turbulence conditions in the constrained dimensions of a wind tunnel, but even to repeat them as often as necessary. This will change the way wind turbine models and their interactions in wind farm configurations can be investigated under controlled and defined external conditions.

I am also impressed by the welcoming and bright architecture of the WindLab building, which accommodates now all of ForWind's wind energy researchers, technicians and management staff in Oldenburg. Furthermore it provides meeting and lecture rooms to host courses, conferences and workshops. This everything-under-one-roof concept creates the creative and innovative atmosphere, which leads to new ideas and solutions that so often originate from coffee-break discussions and spontaneous hall-way encounters.

At the Bremen location of ForWind, the research and test infrastructure extension continues. Already at the horizon is a laboratory that aims at investigating high-performance power electronic systems for wind turbines under realistic environmental and load conditions. It will be used for investigating their failure causes and to develop and to experimentally verify concepts for optimizing their robustness. I am pleased to see that the Federal Ministry for Economic Affairs and Energy is supporting this concept via the HiPE-WiND project, which was granted 12 million Euro in October 2019. This research infrastructure will also be used by ForWind's prime research partner Fraunhofer IWES pursuing the successful and proven collaboration. Commissioning is scheduled for the end of 2019 and I am sure that this facility will be in great demand by both research establishments and industrial partners.

The realisation of these unique research facilities, their acquisition in competitive tenders and their successful implementation and use in projects reflect the success of ForWind as an interdisciplinary and internationally recognized center of expertise. Thus ForWind is excellently positioned to address the challenges of the global energy system transformation and to support the wind energy industry in doing so.



Dr. h.c. Ir. Jos Beurskens
Chairman of the ForWind Advisory Board

PREFACE

This report covers the period of 2015 to 2017. A period with extensions of ForWind's research infrastructures, new member institutes and exciting new research projects and topics.

Of the many research projects carried out in the reporting period, we would like to highlight a few that are outstanding. First, there is "*ventus efficiens* – collaborative research to increase the efficiency of wind turbines in the energy system". This project involves a very large share of all ForWind members and forms the breeding ground on which many new project ideas are generated.

The joint research within the German Research Alliance Wind Energy (FVWE) – a unique strategic cooperation between the German Aerospace Centre (DLR), the Fraunhofer Institute for Wind Energy Systems (IWES), and ForWind – started with the project "Smart Blades – development and construction of smart rotor blades" in 2012. This project, which finished in 2016, was directly succeeded by the project "SmartBlades2 – construction, testing and development of smart rotor blades". The interest of industry, other stakeholders and media in this topic has been exceptional and clearly shows the relevance of such precompetitive research activities.

Despite the vast research infrastructures and laboratories, which are operated and used by the ForWind members, the comparison of research results with reality remains a challenge. Complete verification and validation under real external conditions is only possible to perfection in or on real plants. For several research questions this is impossible to do in commercially operated wind power plants or turbines. The development of the German Research Facility for Wind Energy (DFWind) is therefore a very exciting possibility. The research wind turbines as well as the many accompanying met masts will offer world class opportunities for the wind energy research community and the entire sector. ForWind, DLR, and IWES are working inexhaustibly to make this platform a reality, which hopefully will be the basis for many thrilling joint research projects yet to come.

We are thrilled to have the project "marTech – testing and development of maritime technologies for reliable energy supply" within the ForWind network. This project, which will tremendously increase the capabilities of the large wave flume in Hannover-Marienwerder, is the largest funded project yet. 35 million EUR have been granted by the Federal Government alone, co-funded by state money and investments by the University of Hanover. We are very much looking forward to using the improved large wave flume in research projects in the future.

All ForWind members are especially grateful to the Federal Ministry for Economic Affairs and Energy (BMWi), including the supporting Project Management Jülich (PtJ), and the Ministry for Science and Culture of Lower Saxony (MWK), who are the most prominent sponsors of ForWind's research projects. In addition, the Federal Ministry for Education and Research (BMBF), the German Research Foundation (DFG), the European Commission (EC), and other regional and national sponsors supported us in tackling the challenges of and developing innovations for the wind energy sector.

ForWind is based on interdisciplinary cooperation and as such, we appreciate the stimulating teamwork with our national and international partners from research and industry. Together we will continue to support the entire sector in increasing the value of wind energy to the maximum.

Last but not least, we would like to thank all members of the ForWind Advisory Board for their always very valuable comments, counseling and suggestions as well as all ForWind staff for their unprecedented efforts and enthusiasm.

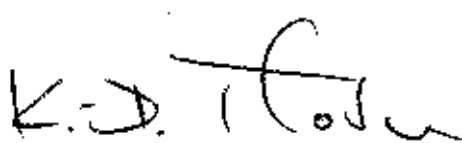

Prof. Dr.-Ing. Klaus-Dieter Thoben
Academic Speaker



Prof. Dr.-Ing. Peter Schaumann
Deputy Speaker

CONTENT

Greeting

Preface

The Organization

• Executive Board	8
• Advisory Board	9
• Participation Institutes	9

Projects

WIND AS A RESOURCE

• Forwind – Small-Scale Wind Field Modelling / Large-Eddy Simulation	10
• Parallel Computing Cluster for CFD and Wind Turbine Modeling	12
• Analysis of the Shadowing Effects and Wake Turbulence Characteristics of Large Offshore Wind Farms by Comparison of <i>alpha ventus</i> and <i>Riffgat</i> (GW Wakes)	15
• ClusterDesign – A Toolbox for Offshore Wind Farm Cluster Design	19
• RealMe – Traceable Acquisition of Meteorological Data	21
• WindScanner.eu – The European WindScanner Facility, Preparatory Phase	22
• European High-performance Infrastructures in Turbulence (EuHIT)	24
• PhD Programme on “System Integration of Renewable Energies”	26
• Turbulence Resolving Simulations for Meteorological Assessment of Wind Energy Sites in Complex Terrain	29
• German Research Facility for Wind Energy (DFWind)	31
• NEWA – New European Wind Atlas Joint Programme	35
• High Performance Computing (HPC) Cluster (WIMS-Cluster)	38
• Further Development of a Two-dimensional Atmospheric Laser Cantilever Anemometer for the High-resolution Investigation of Turbulent Wind Flows for the Optimization of Offshore Wind Turbine Blades	40
• Extended THETA for Site Assessment (ETESIAN)	42
• Highly Accelerated Pitch Bearing Test	44
• Lidar for Wind Energy Deployment (IEA Annex 32) – Phase II	46

SUPPORT STRUCTURES

• GROWup OPC– Grouted Joints for Offshore Wind Energy Converters under Reversed Axial Loadings and Upscaled Thicknesses filled with Ordinary Portland Cement (OPC)	47
• INNWIND.EU – Innovative Wind Conversion Systems (10-20MW) for Offshore Applications	50
• ProBeton – Development and Experimental Testing of Fatigue Resistant Concrete Foundation Structures for Offshore Wind Turbines	52
• HyConCast – Hybrid Substructure of High Strength Concrete and Ductile Iron Castings for Offshore Wind Turbines Cyclic Degradation of Axially Loaded Piles (2013)	55
• Integration of Calculation Methods in the Software Tool <i>IGtHPile</i>	57
• Ventus Efficiens – Joint Research for Raising the Efficiency of Wind Energy Converters within the Energy Supply System Subproject II – Efficiency Enhancement of Supporting Structures	59

• Bearing Behavior of Suction Bucket Foundations under Tensile Loading in Non-cohesive Soils _____	63
• Development and Demonstration of a Rapid and Cost-Effective Installation Concept for Offshore Wind Turbines _____	65
• WinConFat – Fatigue of Materials of Onshore and Offshore Wind Energy Structures Made of Reinforced and Prestressed Concrete under High Cycle Loading _____	67
• ThermoFlight – Concept for the Development of an Opti-mized Maintenance and Inspection Method for Off-Shore Wind Turbines Using Thermography and SHM as Non-Destructive Testing Technologies in Combination with Unmanned Aerial Vehicles _____	69

WIND POWER SYSTEMS

• Development of Nacelle-Based Lidar Technology for Measurement of Power Characteristic and Control of Wind Turbines (LIDAR II) _____	70
• GeCoLab – Test Bench for Generators and Converters Systems _____	72
• EVeQT– Increased Availability and Quality Optimization of Power Train Components and Gears for Wind Energy System _____	74
• BladeMaker _____	75
• CompactWind: Increase of Wind Farm Power Output through Advanced Wind Turbine and Wind Farm Control Algorithms _____	77
• Probabilistic Load Description, Monitoring and Reduction of Loads of Future Offshore Wind Energy Converters (OWEA Loads) _____	80
• Silicon Carbide Power Technology for Energy Efficient Devices (SPEED) _____	83
• Innovation Cluster Power Electronics for Regenerative Energy Supply _____	86
• Manufacturer-independent Retrofitting and Evaluation of the Remaining Life Time of Power Electronic of Wind Turbines with DFIG (WEA-Retrofit) _____	88
• BisWind – Component Integrated Sensor System for Wind Energy Systems _____	91
• Intermittent Wind Loads (InterWiLa) _____	92
• HyRoS – Multifunctional Hybrid Solution for Rotor Blades Protection _____	94
• Adaptive Operation and Control of Offshore Wind Farms Based on Specific Operational Strategies for Optimized Yield, Loads, and Grid Integration (RAVE – OWP Control) _____	96
• Multi-Dimensional Stresses in High Power Electronics of Wind Energy Plants (HiPE-WiND) _____	100
• PiB – Predictive Intelligent Operation System to Reduce the Risk of Icing of Wind Turbines _____	102

WIND ENERGY INTEGRATION

• Advanced Wind Energy Systems Operation and Maintenance Expertise (AWESOME) _____	104
• Resilience of Socio-Technical Systems exemplified at the Electricity Transport and Actor System _____	106
• Influence of Short-time Dynamics of Renewable Energies on the Stability of Power Grids _____	108
• GEOWISOL – Effects of the Geographical Distribution and Temporal Correlation of Wind and Solar Input on the Power Supply System _____	109

STRUCTURAL HEALTH MONITORING

• IR-Vortex – Infrared Thermography as a Measurement Technique for Visualization of Vortex Structures on Rotating Rotor Blades _____	111
• SHM_Rotorblatt: System for Early Damage and Ice Detection for Rotor Blades of Offshore Wind Turbines _____	113
• Monitoring Suction Bucket Jacket – Development of feasible Numerical Simulation Methods for the Investigation of the Compression and Tension Load bearing Behaviour and the Prediction of Displacement Accumulation _____	115
• Multivariate Structural Health Monitoring for Rotor Blades _____	118

- Development and Validation of a Virtual Process Chain for Composite Structural Components Considering Imperfections with Application to a Rotor Blade Component (PROSIM R) _____ 121

Acoustics

- Inflow Noise _____ 123
- WEA-Akzeptanz – From the Source to the Perception _____ 124

Rotor Blades

- Generation of Realistic Turbulent in-Flow Conditions by an Active Grid, Stochastic Analysis of the Resulting Force Dynamics on 2D Segments of Airfoils with Active Control Units _____ 128
- Advanced Aerodynamic Tools for Large Rotors – AVATAR _____ 131
- Hybrid Laminates and Nanoparticle Reinforced Materials for Improved Rotor Blade Structures (LENAH) _____ 134
- Wind Turbine Load Control under Realistic Turbulent In-Flow Conditions _____ 136

Cross-disciplinary Topics

- Smart Blades – Development and Design of Intelligent Rotor Blades _____ 139
- GigaWind life – Life time Research on Support Structures in the Offshore Test Site *alpha ventus* _____ 143
- Innovative Wind Conversion Systems (10-20 MW) for Offshore Applications (INNWIND.EU) _____ 162
- Integrated Research Programme on Wind Energy (IRPWIND) _____ 164
- Extreme Ocean Gravity Waves: Understanding and Predicting Breathers with Wave Breaking and in Coastal Waters _____ 166
- SAMS Save Automation of Maritime Systems _____ 168
- Ventus Efficiens – AP 3 _____ 170
- Ventus Efficiens – Collaborate Research to increase the Efficiency of Wind Turbines in the Energy System _____ 173
- German Research Facility for Wind Energy (DFWind) _____ 178
- Smart Blades 2 – Construction, Testing and Further Development of Intelligent Rotor Blades _____ 184
- Interdisciplinary Research Center on Critical Systems Engineering for Socio-Technical Systems II _____ 188

Qualification and Coordination

- Continuing Studies Programme Wind Energy Technology and Management (“Windstudium”) _____ 190
- European Wind Energy Master (EWEM) _____ 191

ForWind – Events

Events 2015

- Smart Blades Symposium in Oldenburg _____ 192
- Job and Education Fair “zukunftsenergien nordwest” _____ 193
- Hannover Messe 2015 _____ 194
- Visit of the Vice-President for the Energy Union and Energy Minister _____ 196
- Cooperation with Taiwanese University _____ 198

Events 2016

- WindLab – New Research Building for Wind Energy Research _____ 199
- JGenerator Converter Lab (GeCoLab) _____ 201

Events 2017

- Minister President of Lower Saxony Stephan Weil visits ForWind _____ 203
- ForWind Symposia _____ 204

Documentation

PUBLICATION LIST

Peer Reviewed Articles _____	206
Articles, Conference Proceedings, Conference Contributions _____	210
Project Reports _____	218
Public Lectures, Articles in Magazines and Other Publications _____	220
Lectures _____	221
PhD Theses _____	222
Diploma, Master and Bachelor Theses _____	223

LIST OF FORWIND STAFF MEMBERS _____	228
-------------------------------------	-----

IMPRINT _____	238
---------------	-----

FORWIND – CENTER FOR WIND ENERGY RESEARCH

The Organization

ForWind concentrates wind energy research in the northwest and connects 28 institutes and working groups of the universities of Oldenburg, Hannover and Bremen. Thus, ForWind forms a nationwide unique research network and covers a broad spectrum of scientific topics. Research focuses on engineering sciences, physics and meteorology, computational science and economics.

ForWind was founded in 2003 with the support of the Ministry of Science and Culture of Lower Saxony (MWK). Wind energy research at the universities of Oldenburg and Hannover has since been combined in ForWind. In 2009, the University of Bremen joined as a new partner, enabling ForWind to significantly widen its research spectrum once again. ForWind is still supported by the MWK.

Together with the German Aerospace Center (DLR) and the Fraunhofer Institute for Wind Energy Systems IWES, ForWind forms the Research Alliance Wind Energy.



Prof. Dr.-Ing. Bernd Orlik



Prof. Dr.-Ing. habil. Raimund Rolfes



Prof. Dr.-Ing. Klaus-Dieter Thoben



Prof.
Dr. Martin Kühn



Prof. Dr. Joachim Peinke



Prof. Dr.-Ing. Peter Schaumann

Executive Board

ForWind is lead by an Executive Board consisting of two members each of the Carl von Ossietzky University of Oldenburg, the Leibniz University of Hannover and the University of Bremen.

The current board members are Prof. Dr.-Ing. Klaus-Dieter Thoben (1. spokesperson), Prof. Dr.-Ing. Peter Schaumann (2. spokesperson),

Prof. Dr. Martin Kühn,
Prof. Dr.-Ing. Bernd Orlik,
Prof. Dr. Joachim Peinke,
and Prof. Dr.-Ing. habil. Raimund Rolfes.

Advisory Board**Chairman:**

Dr. h.c. Jos Beurskens
Director
SET Analysis, Schagen (NL)

Members:

Dr. Rita Dunker
Advisor
Ministry for Science, Health and
Consumer Protection, Bremen
Department for Universities and
Research

Dr.-Ing. Jörg Hermsmeier
Head of Research and Development
Flender GmbH

Oliver Hilgert
Head of Department Forming and
Application Technology
Salzgitter Mannesmann Forschung
GmbH, Duisburg

Moritz Horn
Managing Director
Van Oord OWP Germany GmbH

Dr. Sebastian Huster
Head of Department Engineering
Sciences and Knowledge Transfer
Ministry of Science and Culture of
Lower Saxony, Hanover

Dr. Klaus Meier
Managing Director
wpd windmanager GmbH & Co. KG,
Bremen

Matthias Schubert
Managing Director
Wyncon GmbH, Hamburg

Lars Weigel
Managing Director
turboMech GmbH & Co. KG,
Uplengen

Guests:

Prof. Dr. Volker Epping
President of the Leibniz Universität
Hannover

Prof. Dr. Dr. Hans Michael Piper
President of the Carl von Ossietzky
Universität Oldenburg

Prof. Dr.-Ing. Bernd Scholz-Reiter
President of the Universität Bremen

Participating Institutes

The following institutes and working
groups at the universities of Oldenburg,
Hannover and Bremen are organized in
ForWind:

Universität Bremen

Bremen Institute for Metrology,
Automation and Quality Science
Prof. Dr.-Ing. habil. Andreas Fischer

Bremen Institute for Mechanical
Engineering
Prof. Dr.-Ing. Bernd Kuhfuß,
Prof. Dr.-Ing. Kirsten Tracht

Institute of Automation
Prof. Dr.-Ing Kai Michels

Institute for Electrical Drives, Power
Electronics and Devices
Prof. Dr.-Ing. Nando Kaminski,
Prof. Dr.-Ing. Bernd Orlik

Institute for Integrated Product
Development
Prof. Dr.-Ing. habil. Klaus-Dieter Thoben

Institute for Microsensors, - actuators and
-systems
Prof. Dr.-Ing. Walter Lang

MARUM – Center for Marine
Environmental Sciences
Prof. Dr. Tobias Mörz

Universität Hannover

Institute for Drive Systems and Power
Electronics
Prof. Dr.-Ing. Axel Mertens,
Prof. Dr.-Ing. Bernd Ponick

Institute for Concrete Construction
Prof. Dr.-Ing. Ludger Lohaus

Institute for Electric Power Systems
Prof. Dr.-Ing. habil. Lutz Hofmann

Institute for Geotechnical Engineering
Prof. Dr.-Ing. Martin Achmus

Institute for Electrical Engineering and
Measurement Technology
Prof. Dr.-Ing. Heyno Garbe

Institute for Machine Design and
Tribology
Prof. Dr.-Ing. Gerhard Poll

Institute for Building Materials Science
Prof. Dr.-Ing. Steffen Marx

Institute of Meteorology and Climatology
apl. Prof. Dr. Siegfried Raasch

Institute for Steel Construction
Prof. Dr.-Ing. Peter Schaumann

Institute of Structural Analysis
Prof. Dr.-Ing. habil. Raimund Rolfes

Institute of Turbomachinery and Fluid
Dynamics
Prof. Dr.-Ing. Jörg Seume

Institute for Wind Energy Systems
Prof. Dr.-Ing. Andreas Reuter

Institute for Business Informatics
Prof. Dr. Michael H. Breitner

Ludwig-Franzius-Institute for Hydraulic,
Estuarine and Coastal Engineering
Prof. Dr.-Ing. habil. Thorsten Schlurmann

Universität Oldenburg

Computing Science, Business Engineering
Prof. Dr.-Ing. Axel Hahn

Institute of Physics, Energy Meteorology
Dr. Detlev Heinemann

Institute of Physics, Turbulence,
Wind Energy and Stochastics
Prof. Dr. Joachim Peinke

Institute of Physics, Wind Energy Systems
Prof. Dr. Martin Kühn

Forwind – Small-Scale Wind Field Modelling / Large-Eddy Simulation

Carl von Ossietzky Universität Oldenburg
Institute of Physics,
Research group: Energy Meteorology

Martin Dörenkämper, Sonja Drüke,
Sonja Krüger, Isabelle Prestel,
Michael Schmidt, Lars Segelken,
Gerald Steinfeld, Lukas Vollmer,
David Wagner, Björn Witha,
Hauke Wurps, Detlev Heinemann

Funding: Ministry for Science and Culture
of the Federal State of Lower Saxony

Ref.Nr. N.A.

Duration: 12/2009 – 11/2015

Introduction

The atmospheric boundary layer (ABL) is the part of the atmosphere in which wind turbines are operating most of their lifetime. It is the layer of the atmosphere in which the impact of the ground surface can be felt in the flow conditions. The flow conditions in the ABL are characterized by turbulence. The turbulent motions in the ABL cover scales from some millimeters to some thousands of meters. The convective ABL is characterized by especially strong turbulence, while in situations with stable stratification the turbulence in the ABL is characterized by a more intermittent character. Besides the stability the roughness of the underlying surface and also the topography of the terrain play a key role for the generation of turbulence in the ABL. As turbulence causes loads on wind turbines a better understanding of atmospheric turbulence can help to optimize the design of wind turbines with regards to the expected turbulence conditions at a certain site.

Wind turbines interact with the flow in the ABL. This means that not only the wind turbine behavior depends on the flow in the ABL, but also the flow in the ABL is modified when it passes a wind turbine. Wind turbine wakes are characterized by reduced wind speeds compared to the undisturbed ambient flow and by additional turbulence. This additional turbulence is caused e.g. by the strong shear of wind speed in the transition region between wake and ambient flow.

Measurements in the real atmosphere as well as in the wind tunnel aim at obtaining a better understanding of turbulent flows. Besides those two approaches turbulence resolving numerical models are widely used in order to gain a better knowledge on flow conditions in the ABL and within wind farms. One limiting boundary condition to numerical modelling of ABL flows is the wide range of scales of turbulent motions in the ABL. The wide range of scales prevents an investigation with the means of direct numerical simulation for most ABL flows. Large-eddy simulation (LES), which follows the approach of explicitly resolving the bulk of the turbulent motions in the ABL while parameterizing the impact of smaller scale turbulence on the resolved scales, is the state-of-the-art approach for in-depth analyses of turbulent ABL flows. Due to the limitation of computational resources today in numerical simulations the flow at the rotor blades cannot be resolved explicitly if also the whole ABL and its interactions with several wind turbines is simulated. Therefore, studies that aim at investigating the interactions between the ABL and wind farms require parameterizations in order to account for the effect of wind turbines on the atmospheric flow.

The small scale wind field modelling team is a sub-group within the Energy Meteorology group of ForWind. The members of the group use the LES model PALM [1] in order to study the interaction between atmospheric

flows for different stratifications, surfaces and topographies with wind turbines. Different wind turbine parameterizations have been implemented into the LES code PALM and these parameterizations are continuously further developed. The final objective of the team is to transfer the knowledge gained from simulations with the pure research tool PALM into improved parameterizations for models used in the wind energy business, such as wind farm parameterizations for mesoscale models or improvements for engineering wake models.

Project Description

Accounting for wind turbines in the large eddy simulation model PALM

Since 2009 different wind turbine models have been implemented into the LES model PALM by members of the small scale wind field modelling group. The available models include different types of actuator disc approaches, an actuator line approach, an enhanced actuator disc model with rotation and finally also an enhanced actuator line approach, in which the aerodynamic forces acting on the rotor blade segments are obtained by coupling the large-eddy simulation model PALM with an aeroelastic code such as FLEX or FAST. The latest implementation of the small scale wind field modeling group into the LES model PALM is an actuator sector method. This method provides still a coupling with the aeroelastic code FAST, but is considerably faster than the actuator line approach, as it allows for larger time-steps.

A major achievement of the members of the small scale wind field modelling group within the reporting period was the integration of the actuator disc model with rotation and the simple actuator disc model into the standard code of PALM. This means that now also other groups can use the developments that have been done at ForWind by

just downloading a recent version of the PALM code. This has led e.g. to the application of PALM for wind energy studies at the TU Delft in the Netherlands and in other groups of ForWind.

The enhanced actuator disc model was e.g. used to study the impact of atmospheric stability on the recovery of wakes within wind farms. The wind turbine models implemented in PALM are continuously verified and improved. One example is e.g. the implementation of different tip-loss correction models into the actuator line and enhanced actuator disc model.

The small scale wind field modelling group of the Energy Meteorology group at ForWind is an active participant and coordinator of German activities in the IEA task 31 “Wakebench”. The IEA task provides a number of benchmarks for flow models for wind energy applications. The participation in these benchmarks is one of the main approaches that are followed in order to verify the wind turbine parameterizations that have been implemented in PALM.

Recently, the small scale wind field modelling group has also contributed to a field experiment that aimed at providing validation data for flow models for wind energy applications. The field experiment took part at a wind farm site consisting of two wind turbines in moderately complex terrain in North-Eastern Germany.

Another focus of the small scale wind field modelling team within the Energy Meteorology group was on the implementation of a dynamic sub-grid scale model into the LES code PALM.

Development of wind farm control strategies

In the reporting period the focus concerning the development of wind farm control strategies was on the method of deflecting wind turbine wakes by intentional misalignment of wind turbines with the wind direction. By numerical experiments with PALM it could be shown that the atmospheric stability is a key parameter for the shape and position of the wind turbine wake. Different yaw angles

for the intentional misalignment of the wind turbine are required to have the wake at the same position for different atmospheric stabilities. Furthermore, it could be shown that the concept of wake deflection by intentional yaw misalignment works well for cases of stable stratification while the concept could not successfully be applied under unstable stratification [2].

Improvement of the engineering wake model FLaP

ForWind’s in-house engineering wake model, the Farm Layout Program (FLaP) [3] has been further developed by coupling it to an analytic wind farm wake model in the reporting period. This means that FLaP can now also be applied for the investigation of the impact of the layout of new wind farms inside existing wind farm clusters.

Flows in complex terrains

In the reporting period members of ForWind took part in the micro-scale model comparison at the moderately complex forested site Ryningsnäs. This benchmark offered an ideal opportunity to validate the

plant canopy model that is available in the LES model PALM. The successful participation in the benchmark provided further trust in the model PALM to apply it also to other forested sites.

Summary

The LES model PALM has been used at ForWind to study the flow conditions in the ABL, the interaction between the atmospheric flow and wind energy converters, the flow conditions within as well as the flow conditions downstream of wind farms. The objective is to gain a deeper insight into these flows and to transfer the knowledge gained to improvements for fast, engineering wake models, the development of wind farm parameterizations for larger-scale models or simply better descriptions of turbulent processes in mesoscale models. The wind turbine models implemented in PALM since 2009 have been further developed in the reporting period. In the reporting period intensive work on the verification of the developed approaches was in progress.

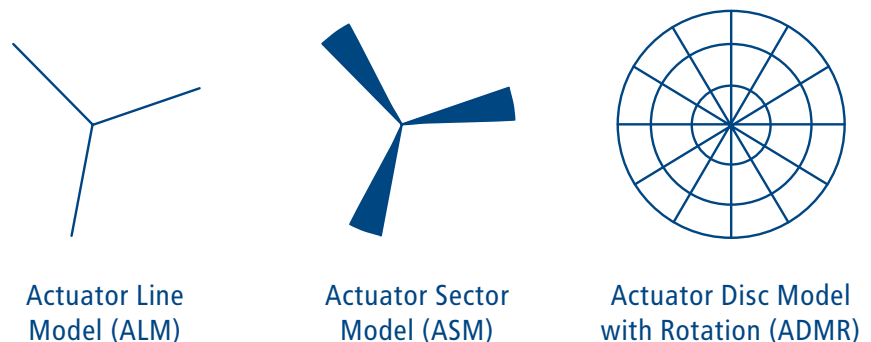

Figure 1: Actuator models

References

- [1] Raasch, S.; Schröter, M.: PALM – A large-eddy simulation model performing on massively parallel computers, *Meteorol. Z.* 10 (2001)
 [2] Vollmer, L.; Steinfeld, G.; Heinemann, D.; Kühn, M.: Estimating the wake deflection downstream of a wind turbine in different atmospheric

stabilities: an LES study, *Wind Energy Sci.*, 1, 129-141, <https://doi.org/10.5194/wes-1-129-2016>, 2016.

- [3] Lange, B.; Waldl, H.-P.; Gil Guerrero, A.; Heinemann, D.; Barthelmie, R.J.: Modelling of Offshore Wind Turbine Wakes with the Wind Farm Program FLaP, *Wind Energy* 6 (2003)

Parallel Computing Cluster for CFD and Wind Turbine Modeling

Carl von Ossietzky Universität Oldenburg
Research Group: Wind Energy
Meteorology

Björn Witha, Stefan Albensoeder,
Wided Medjroubi, Detlev Heinemann,
Joachim Peinke

Funding: Federal Ministry for Economic
Affairs and Energy (BMWi)

Ref.Nr. 0325220

Duration: 07/2010 – 05/2015

Introduction

In wind energy research computational fluid dynamics (CFD) is an essential tool to improve blades and complete wind energy turbines, to better understand wake effects and the interaction of wakes in wind farms. Today's simulations resolve more details and enable the coupling of large and small scale effects. However, to perform these simulations, powerful computational resources are required.

For this purpose, the ForWind/Fraunhofer alliance has been supplied with an own High-Performance Computing (HPC)-facility called FLOW (Facility for Large-Scale Computations in Wind Energy Research). The HPC-cluster is designed for highly parallelized computations and contains more than 2200 cores with a high-performance interconnect and a large storage system.

In the scientific part of the project Large-Eddy Simulations (LES) with the software PALM are performed to investigate the interaction of the atmospheric boundary layer with the wakes of wind turbines. On smaller scales the computations of loads of wind turbines will be improved by simulations with the software OpenFOAM.

The project ended on 31.05.2015, the final report has been published [1].

Project Description

HPC operation

The operational support of the HPC FLOW system and the user support are included in the project. This covers the installation and optimization of software as well as investigations in case of problems and introduction into HPC for users. Further tasks are the coordination between the IT-department and ForWind, and the extension of the HPC system by new or additional hardware.

The FLOW cluster has been running very stably and operated at full capacity for most of the time. Downtimes were in most cases planned, e.g. due to the move of the cluster into the new facilities of the university IT services. In early 2015 the operational system was replaced and the job management systems was re-configured leading to an improved performance of the cluster.

Wake simulations with the LES model PALM

A main task of the project was the further development of wind turbine parameterizations in the LES model PALM [2] to simu-

late the interaction between the atmospheric boundary layer and wind turbine wakes.

Three turbine parameterizations have been implemented in PALM [3] (see also Fig. 1): A simple and fast actuator disk model (ADM), a much more accurate but computationally expensive actuator line model (ALM) and an enhanced actuator disk model with rotation (ADM-R) which considers a distribution of forces over the rotor disk and the rotation of the blades as the ALM but which is much faster.

The turbine parameterizations have been enhanced by turbine control features like speed and yaw control in the framework of the project CompactWind.

In 2016 (after the end of the Parallel Computing Cluster project) the ADM-R including the turbine controller have been implemented in the default version of PALM and is thus available for public use [4].

In the final stage of the project the work on simulating large and infinite wind farms was continued. A joint publication for the Wake Conference 2015 in Visby was written and published together with Technical University of Denmark and Uppsala University [5].

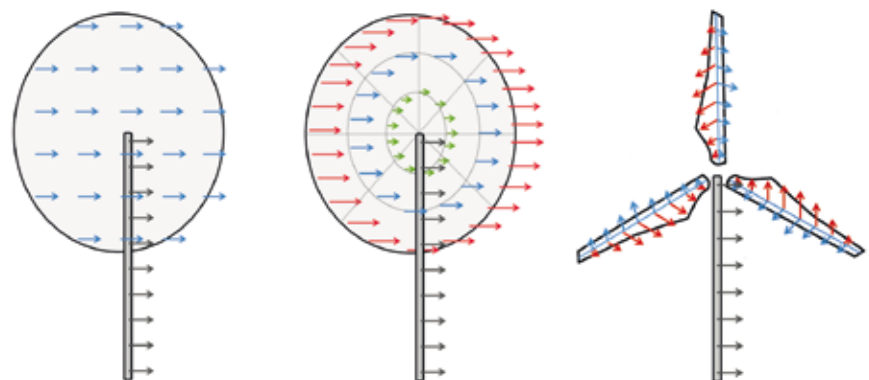

Figure 1: Schematic representation of the three turbine models implemented in PALM: ADM (left), ADM-R (center), ALM (right)

Furthermore, the flow over complex terrain has been investigated, starting with a typical idealized 2D sinusoidal mountain ridge test case. After verification with previous studies and sensitivity studies with different resolutions and aspect ratios of the hill, wind turbines have been placed on the hill top (see Fig. 2).

To account for realistic weather situations, a one-way coupling between PALM and the mesoscale models WRF and COSMO was tested. The coupling method itself is pro-

vided with the default PALM version. It has been complemented by scripts that convert data from WRF output files to the input format required in PALM and that allow averaging over several WRF grid points.

A further objective of the scientific work in the project was the investigation of coherent structures in offshore wake flows which have a strong effect on power production and loads. Wakes simulated by LES have been analyzed by means of power spectra and autocorrelations. For a single wake no

connection between the wake meandering and the vortex shedding behind the rotor disk was found. A connection between the meandering and large eddies in the background flow seems to exist but could not be quantified.

Simulation of the flow around wind turbine blades

Different CFD methods have been compared for the laminar flow around two wind turbines, the NREL Phase VI turbine and a multi-megawatt turbine: The conventional RANS (Reynolds Averaged Navier Stokes) method, the time-resolving URANS (Unsteady RANS) and DDES (Delayed Detached Eddy Simulations) which combine the advantages of RANS and LES in one simulation. It could be shown that it is possible to simulate a full turbine with DDES with results similar to the URANS model. Although URANS could yield slightly more accurate global results for power and thrust, DDES showed benefits for the local pressure coefficients. To further increase the accuracy of the simulation, the CFD solver OpenFOAM [6] was coupled to a structure solver developed at ForWind allowing to consider flexible blade geometries typical for multi megawatt turbines (see Fig. 3).

Further work was dedicated to the testing of different turbulent inflow conditions. All tested methods have their pros and cons and no method is generally superior or inferior. Depending on the application different methods can be recommended. Results

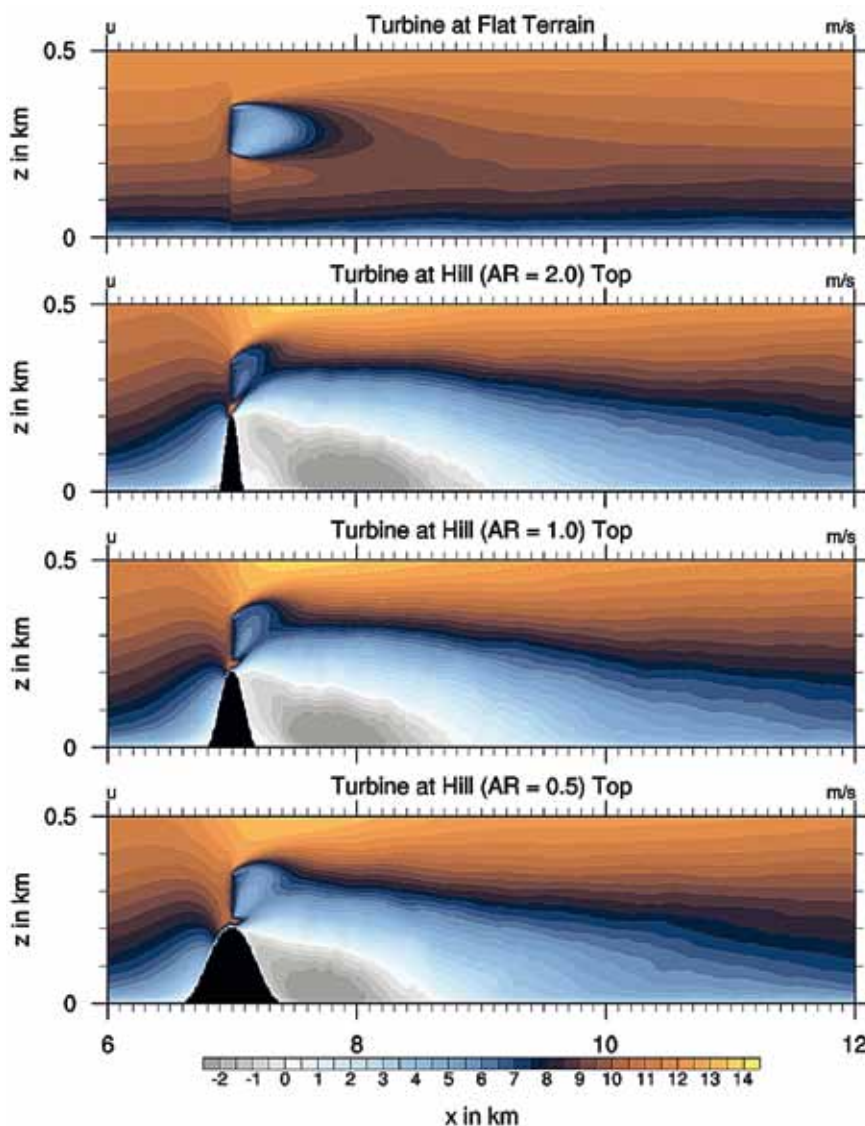

figure 2: Flow across a sinusoidal mountain ridge with a wind turbine placed at hill top for three different aspect ratios of the hill and a flat reference case. Shown is the horizontal wind speed (u-component in m/s).

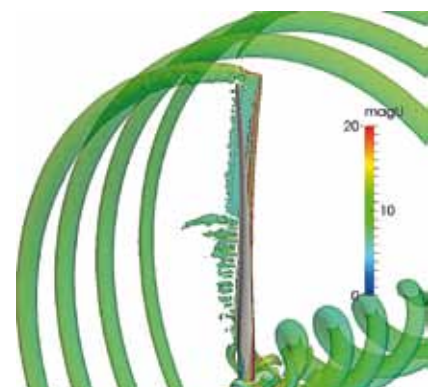

Figure 3: Wake flow behind a deformed flexible blade geometry for an inflow speed of 10.9 m/s

of full turbine simulations have shown that turbulence has a strong effect on the load dynamics of a turbine. However, the effect of turbulence depends on many parameters, e.g. the turbine design, the turbulence intensity and the dynamics of the turbulence. Thus, future work is required to investigate the interaction between turbulence and wind turbines.

Another objective of the scientific work in this project is to gain an improved understanding of the physical mechanisms of flow separation at rotor blades and to improve the accuracy of numerical simulations of separated flow. Of particular relevance is the flow separation in connection with radial flows and the Himmelskamp effect which can lead to delayed flow separation. When investigating the effect of blade rotation on the aerodynamic coefficients, it has been found that the effects of rotation on the drag force are airfoil-type dependent. Thus, the development of a general correction model is challenging. Significantly improved simulation results could be obtained after a modification of the Spalart turbulence model [7].

A comparison study between laminar and turbulent inflow conditions disclosed several qualitative and quantitative differences with respect to performance and loading

of the investigated wind turbine model. The turbulent inflow results show not only a stronger fluctuation of the loads but also a reduction of the mean driving tangential force. The axial loads which are directly related to the thrust are affected in a similar way (see Fig. 4). Furthermore, a stronger mixing of the wake could be observed in the turbulent case leading to an early recovery of the flow.

Summary

Several wind energy projects benefit from the HPC cluster FLOW that was installed as a part of this project. The cluster is operating at full capacity and performs very well.

In the scientific part of the project, different wind turbine parameterizations in the LES model PALM have been enhanced and compared. They are used in this and other projects to investigate the interaction between the atmospheric boundary layer and wind turbine wake. The scales reach from single wakes up to very large and infinite wind farms. Wakes in different types of terrain are simulated, from offshore and flat to forested and hilly terrain.

The second focus of the scientific work in this project is on the details of the flow

around wind turbine blades which was simulated with OpenFOAM and investigated in terms of aerodynamic characteristics. The results stress the lack of generality of the knowledge concerning rotational effects and the need for extensive research in this field using full rotor simulations.

References

- [1] Peinke, J. (Hrsg.): Parallelrechner-Cluster für CFD und WEA Modellierung, Abschlussbericht des Forschungsprojektes, Laufzeit: 01.07.2010-31.05.2015, ForWind - Carl von Ossietzky Universität Oldenburg, doi: 10.2314/GBV:867679581 (2015)
- [2] Maronga, B.; Gryschka, M.; Heinze, R.; Hoffmann, F.; Kanani-Sühring, F.; Keck, M.; Ketelsen, K.; Letzel, M. O.; Sühring, M.; Raasch, S.: The Parallelized Large-Eddy Simulation Model (PALM) version 4.0 for atmospheric and oceanic flows: model formulation, recent developments, and future perspectives, *Geosci. Model Dev.*, 8, 2515–2551, doi:10.5194/gmd-8-2515-2015 (2015)
- [3] Steinfeld, G.; Witha, B.; Dörenkämper, M.; Gryschka, M.: Hochauflösende Large-Eddy Simulationen zur Untersuchung der Strömungsverhältnisse in Offshore-Windparks. *promet-meteorologische Fortbildung*, 39, pp. 163-180 (2015)
- [4] Witha, B.: Description of the PALM wind turbine model, <https://palm.muk.uni-hannover.de/trac/wiki/doc/tec/wtm>, last accessed on Dec. 03 (2018)
- [5] Andersen, S. J.; Witha, B.; Breton, S.-P.; Sørensen, J. N.; Mikkelsen, R. F.; Ivanell, S.: Quantifying variability of Large Eddy Simulations of very large wind farms, *J. Phys.: Conf. Ser.*, p. 625, 012027, doi: 10.1088/1742-6596/625/1/012027 (2015)
- [6] <http://www.openfoam.com/>
- [7] Spalart, P. R.; Allmaras, S. R.: A one-equation turbulence model for aerodynamics flows, *La Recherche Aeronautique*, 1(1), pp. 5-21 (1994).

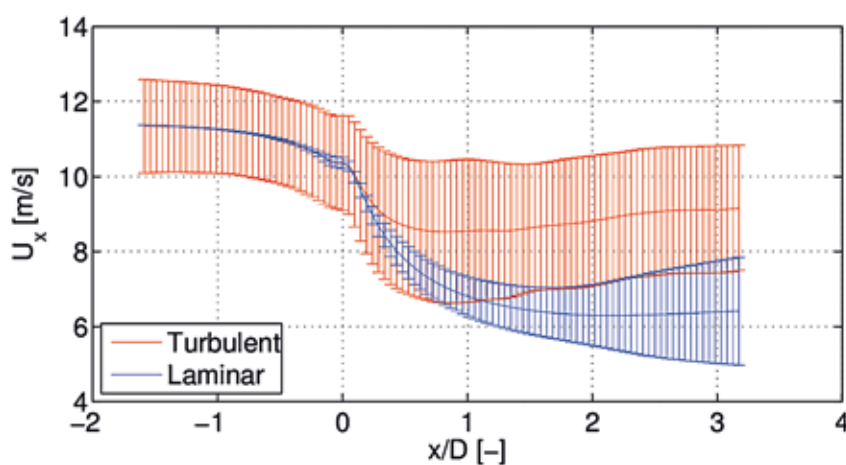

Figure 4: Turbine wake (axial velocity component) for laminar and turbulent flow along the transverse at $r/R = 1$ (blade tip).

Analysis of Shadowing Effects and Wake Turbulence Characteristics of Large Offshore-Wind Farms by Comparison of *alpha ventus* and *Riffgat* (GW Wakes)

Carl von Ossietzky Universität Oldenburg,
Institute of Physics
Research Group: Wind Energy Systems
Research Group: Turbulence, Wind Energy
and Stochastics
Research Group: Energy Meteorology

Teklehaimanot Zere Aman, David Bastine,
Hauke Beck, Martin Dörenkämper,
Marijn Floris van Dooren,
Wilm Friedrichs, Paul Gerke Funcke,
Detlev Heinemann, Julian Hieronimus,
Martin Kühn, Michael Schmidt,
Jörg Schneemann, Gerald Steinfeld,
Davide Trabucchi, Juan José Trujillo,
Lukas Vollmer, Stephan Voß,
Matthias Wächter, Björn Witha

Partner: Fraunhofer IWES

Funding: Federal Ministry for Economic
Affairs and Energy (BMWi)

Ref.Nr. 0325397A

Duration: 08/2011 – 09/2016

Introduction

The goal of the GW Wakes project was to better understand the wake effects in large offshore wind farms in order to optimize the design and operation of offshore wind farms in the future with regard to shadow losses due to wake and wind farm turbulence.

For this purpose, laser-optical measurements and high-resolution numerical simulations of the wind farm flow were carried out. Furthermore, a new model of the wake flow and a software for optimizing the layout of new wind farms were developed.

Project Description

Measurement campaigns:

Two offshore measurement campaigns were carried out by ForWind – University of Oldenburg as part of the GW Wakes joint research project: The first in the German offshore test field *alpha ventus* and the second in the offshore wind farm *Riffgat*, both in the German North Sea. In addition to meteorological parameters, the wake flow behind wind turbines in the wind farm was measured with the remote sensing method Lidar (Light detection and ranging) and the surface temperature of the sea was measured with a measuring buoy to derive atmospheric stability. In *alpha ventus*, the existing measurement infrastructure of the RAVE initiative (Research at *alpha ventus*) could also be used and the lidar systems, for example, compared with the existing Fino1 met mast.

In *Riffgat*, measurements could then be taken in a larger wind farm in which up to tenfold superimposed wakes occur. This is a typical scenario for the offshore wind farms planned and built today.

The data measured within GW Wakes will be used in particular for the development of new models of wind turbine tracking and for the validation of numerical simulations of the maritime boundary layer and the wind farm flow contained therein. The data will continue to provide important insights for future research.

Furthermore, the lidar data from GW Wakes could also be used for a comparison with wind measurements from the radar satellite TerraSAR-X (TS-X). It was shown for the first time that the spatial structures in the two simultaneously measured wind fields of TS-X and the lidar systems are

very similar. TS-X has so far only been compared using local point measurements or modelled wind fields. Both measuring systems can complement each other in the future, since TS-X measurements can cover very large regions, but continuous measurements are not possible (approximately every two to three days). Lidar offers a comparatively smaller measurement range, but can continuously scan the region around the instrument with a higher accuracy.

Shading losses:

Due to the special arrangement of the wind turbines in the *Riffgat* wind farm (3 rows with 10 turbines each), conditions arise for certain wind directions which are to be expected regularly in even larger wind farms. For example, there are wind turbines for northeast and southwest wind that are shaded by up to 9 turbines. In the course of the project, however, it became apparent that the greatest power losses do not occur at the rearmost wind turbines, but at the turbines in the middle of the wind farm. The reason for this is that a sufficiently large wind farm acts on the flow like an almost solid obstacle and is surrounded by an external flow. The rear turbines already notice the acceleration of the flow on the leeward side of the obstacle.

In view of the frequent situation in the North Sea in the future that another wind farm is located downstream, it was shown that the *Riffgat* wind farm influences the wind speed far more than 10 km downstream.

On the basis of these findings, the potential of wind energy utilisation in the North Sea for the planned future expansion of offshore wind farms was calculated.



Figure 1: Lidar system with large measuring range on the transition piece of a wind turbine in the *Riffgat* offshore wind farm

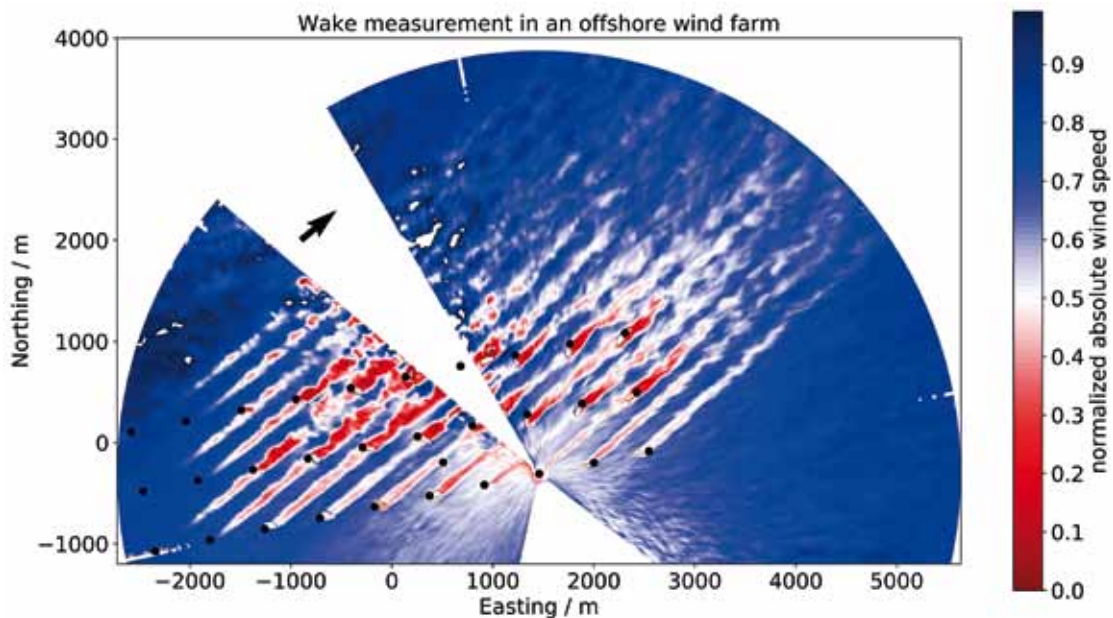

Figure 2: Wind field in the *Riffgat* offshore wind farm. Absolute wind speed with assumed constant wind direction (arrow). The underlying lidar scan used a constant elevation of 2.5° , so that the measuring height from the center to the outside constantly increases. In the southern white sector the view was blocked for the lidar system, the northern sector was hidden because the error is too high for the calculation of the absolute wind speed. The wake of the wind turbines in the wind farm can be clearly seen, they mix behind the wind farm to form the park wake.

Comparison of flow simulation with lidar measurements

The newly developed method for model validation enables the directly comparison of flow measurements with high-resolution physical models for the first time. The good agreement (see fig. 5) strengthens the further application of these models as a data basis for models for wind farm planning.

Wake turbulence:

The wake flows of wind turbines (WTGs) are very complex. In particular, there is a very large range of relevant size scales

from kilometre-long atmospheric structures to small-scale turbulence that extends into the mm range.

For such small scales the investigations showed a surprising similarity to the idealized turbulence in the laboratory, so that strongly simplified models can be considered [2].

The complicated shape changes in the cross-section of the wake flow, on the other hand, could well be described as superposition of different so-called modes. The slow direc-

tional changes of the wake (the so-called meandering) are again caused by kilometre-long structures of the atmospheric wind.

In order to describe the overall wake, it seems appropriate to divide the models according to the above-mentioned orders of magnitude. In order not to develop models that are too complicated, the description must always keep the application in mind. For example, a different description will be suitable for the loads on a wind turbine than for the energy yield of an entire wind farm [2].

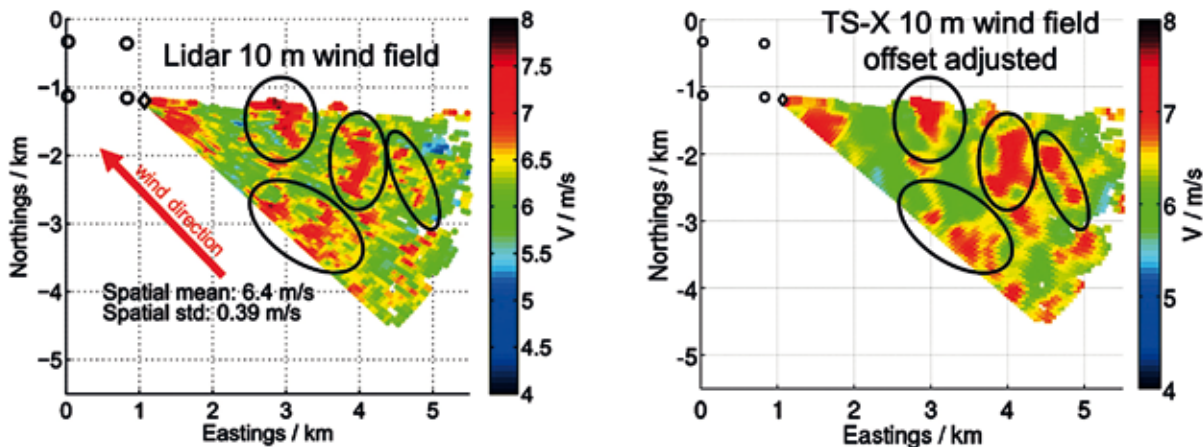

Figure 3: Simultaneous measurement with different sensor systems: Left: Wind field measured with lidar on offshore platform, right: Wind field determined from the data of the radar satellite TerraSAR-X, the data were corrected by an offset. Regions with very similar turbulence structures are marked in black ellipses [5].

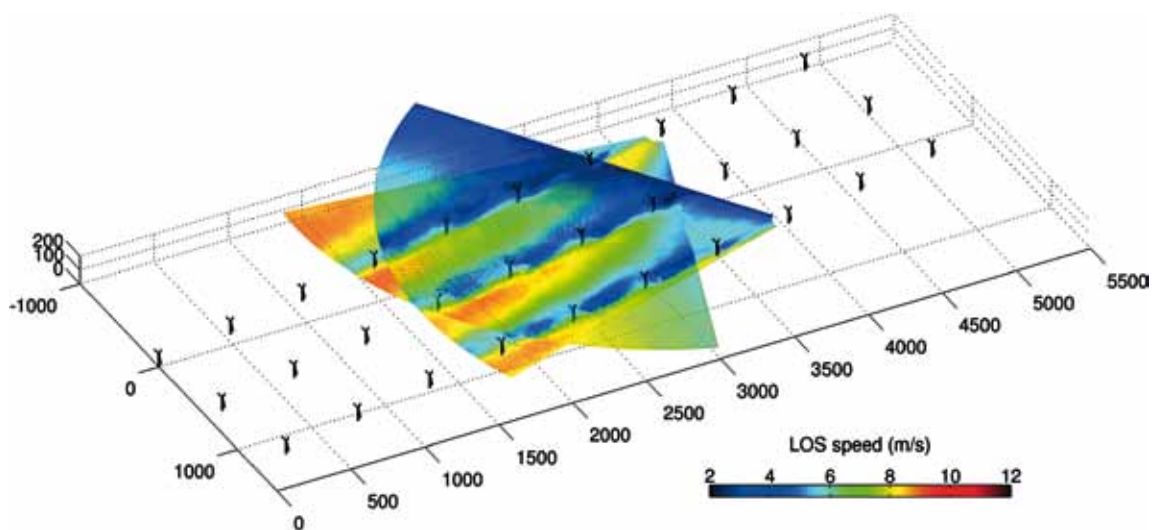

Figure 4: Flow measurement in the Riffgat wind farm with two laser-optical remote sensing devices (Windlidar)

Wake model:

For a more accurate prediction of wind farm performance and for more accurate results from software used to optimize the layout of offshore wind farms, within GW Wakes the "3D Shear Layer Wake Model" was developed. This is a new wake model which, based on physical principles, is better suited for the complex wind flows within a wind farm than the models normally used in engineering software for wind farm planning.

Technology transfer:

Turbulence-resolving Large Eddy (LES) wind farm simulations, such as those car-

ried out in the GW Wakes project, require immense computing capacity and time. For engineering consultants and wind farm planners, neither the corresponding computer hardware nor the required time is normally available, so in practice, highly simplistic calculation methods and models are used.

The transfer from research to applied wind farm planning has been realized by Fraunhofer IWES within GW Wakes with the software "flapFOAM". This is a wind farm and wake modelling software that can calculate a power prediction for a wind farm with little time expenditure. The results of

complex simulations of individual wind turbines are incorporated into these calculations. They were prepared in advance and stored as a result table.

Through this novel coupling of complex numerical calculations and fast modelling, the results of current research in the field of wind turbine simulation can be used for wind farm planning and optimisation tasks. For validation purposes, the results were compared with standard tracking models on the one hand and with RANS and LES simulation results of the Riffgat wind farm on the other [3].

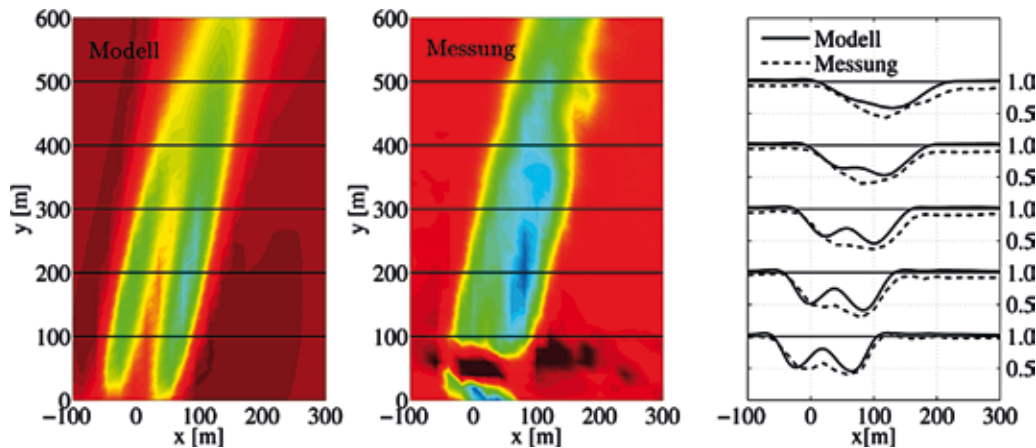

Figure 5: Comparison between model and measurement for a wake flow in alpha ventus on 20 February 2014. The model explicitly takes into account the meteorological conditions measured at the neighbouring measuring mast FINO1. [Figure: Lukas Vollmer, ForWind, University of Oldenburg] Further information: [Vollmer 2015]

References

- [1] Bastine, D.; Wächter, M.; Peinke, J.; Trabucchi, D.; Kühn, M.: Characterizing Wake Turbulence with Staring Lidar Measurements Journal of Physics: Conference Series, IOP Publishing, 2015, 625, 012006
- [2] Bastine, D.; Witha, B.; Wächter, M.; Peinke, J.: Towards a Simplified DynamicWake Model Using POD Analysis Energies, 2015, 8, 895
- [3] Schmidt, J.; Stoevesandt, B. The impact of wake models on wind farm layout optimization Journal of Physics: Conference Series, 2015, 625, 012040
- [4] Schneemann, J.; Bastine, D.; v. Dooren, M.; Schmidt, J.; Steinfeld, G.; Trabucchi, D.; Trujillo, J. J.; Vollmer, L.; Kühn, M.: "GW WAKES": Measurements of wake effects in *alpha ventus* with synchronised long-range lidar windscanners, Proceedings of the German Wind Energy Conference DEWEK, 2015
- [5] Schneemann, J.; Hieronimus, J.; Jacobsen, S.; Lehner, S.; Kühn, M.: Offshore wind farm flow measured by complementary remote sensing techniques: radar satellite TerraSAR-X and lidar windscanners Journal of Physics: Conference Series, 2015, 625, 012015
- [6] Vollmer, L.; van Dooren, M.; Trabucchi, D.; Schneemann, J.; Steinfeld, G.; Witha, B.; Trujillo, J.; Kühn, M.: First comparison of LES of an offshore wind turbine wake with dual-Doppler lidar measurements in a German offshore wind farm Journal of Physics: Conference Series, 2015, 625, 012001
- [7] Abschlussbericht: <https://doi.org/10.2314/GBV:886719402>

ClusterDesign – A Toolbox for Offshore Wind Farm Cluster Design

Carl von Ossietzky Universität Oldenburg
Institute of Physics
Research group Energy Meteorology,
Wind Energy Systems

Sonja Drüke, Robert Günther,
Detlev Heinemann, Michael Schmidt,
Gerald Steinfeld

Funding: EU

Ref.Nr. FP7-Energy-2011 283145 / Cluster-
Design

Duration: 12/2011 – 05/2016

Introduction

A consortium consisting of the six partners 3E, ECN, Imperial College, RWE Innogy, Senvion and ForWind with its working groups Energy Meteorology and Wind Energy Systems, collaborated from 2011 to 2016 in the EU project ClusterDesign [1]. The main objective of the project was the development of a toolbox for the integrated design of offshore wind farm clusters. For that purpose, different wind farm design tools were combined in one toolbox. This toolbox facilitates finding solutions that meet multiple criteria such as a maximization of energy extraction, a reduced uncertainty of energy yield estimates, a maximization of the ratio between income and costs as well as a maximization of the power system support capability.

The project was based on four main elements:

1. Modelling: Existing models, each aiming at optimizing major wind farm functionalities related to design and control have been further developed. The functionalities included power production, loads and power system support. The set of models consisted of advanced wake models, electrical connection models, virtual

power plant operation models, load and performance models and related wind farm control concepts.

2. Integration: The aforementioned models were integrated into a single toolbox allowing for an integrated wind farm cluster design.
3. Validation: The single models as well as the toolbox as a whole were validated against data obtained from measurement campaigns within the project that took place in operating wind farms.
4. Valorisation: In the end, the results of the project were transformed into an industrial applicable solution ensuring a significant impact of the developed solutions.

Project Description

Within the ClusterDesign project the main tasks of ForWind were the further development of wake models, the generation of a wind atlas for the Southern North Sea as well as the contribution to a field experiment in an operating offshore wind farm with a nacelle-based LiDAR.

Aiming at the development of a high-fidelity tool for the simulation of flow conditions and loads in a wind farm a coupling between the large-eddy simulation model PALM and the aeroelastic code Flex5 was established in collaboration with load experts from Senvion.

Due to porting of the code a considerable speed-up of ForWind's in-house wake model FLAP could be reached. Another modification that has been done to FLAP in the project was the implementation of an analytical wind farm model that allows for taking the shadowing effects of neighbouring farms on a target wind farm into account. Therefore, FLAP can now be used to calculate the flow conditions in and energy output of wind farms that are in the wake of other wind farms, i.e. FLAP has been further

developed to a wind farm cluster model. Benchmark runs carried out within the project showed that the Ainslie model in FLAP can deliver results that are in good agreement with much more complex, but considerably slower wake models. Due to its low computational demand, FLAP is well-suited for an evaluation of a huge number of different layouts of a wind farm in order to select a number of promising ones that might be worth of further to be investigated with a slower, but more accurate wake model. Such a combination of slower and faster wake models might contribute to the reduction of computational time required for the optimization of a wind farm layout.

Within the project a unique high-quality LiDAR data set comprising several months of measurements of the flow conditions in an offshore wind farm has been generated by applying a nacelle-based long-range LiDAR system of ForWind. The value of this data set has already been shown in the framework of the ClusterDesign project, as the wake models of the partners ECN and ForWind could be improved based on the data from this measurement campaign.

Within the project ForWind used the concept of a dynamical downscaling of reanalysis data with the mesoscale model WRF in order to generate a wind and stability atlas (WASA) for the Southern North Sea. Before information on the atmospheric conditions in that region with a horizontal resolution of 2 km for the time period between 1993 and 2012 could be generated, some efforts were spent on finding the most appropriate setup of the WRF simulations. Comparisons showed that the setup finally used for the WASA generation was in better agreement with the measurements than previous results obtained with WRF and published in literature. A major characteristic of the WASA is that it provides time series of wind energy relevant parameters instead of merely statistical information. This makes the data very

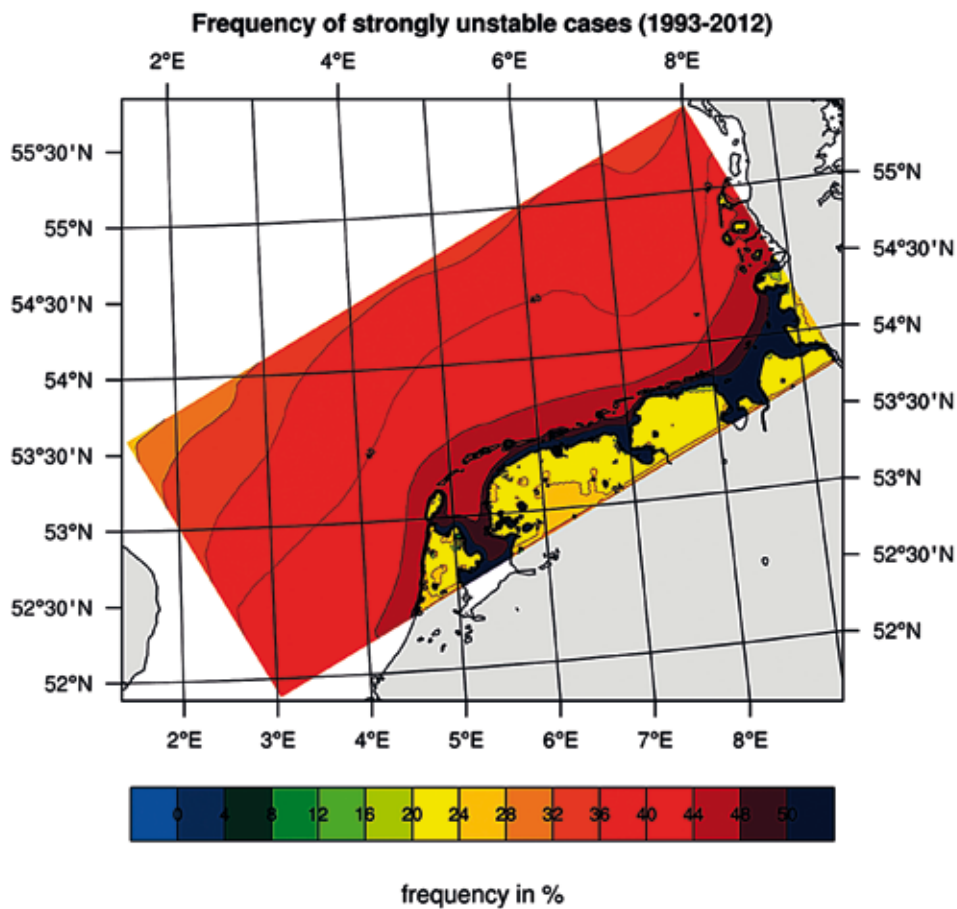

Figure 1: Share of situations with strongly unstable stratification in the period between 1993 and 2012 for the region of the Wind and Stability Atlas.

easy to be handled by wake models and preserves the observed correlation between the different atmospheric parameters.

Summary

Six partners from academia and research including ForWind worked together in the EU project ClusterDesign. The partners aimed at developing a toolbox for the design of offshore wind farm clusters that gives accurate projections of energy production and fatigue-life consumption, that allows for accounting for wind shadows caused by neighbouring wind farms and that allows for controlling each farm with the aim to maximize the production. The final toolbox comprises a meso-scale wind and stability atlas with a resolution of 2 km for the Southern North Sea produced by ForWind that is based on 20 years of simulations with the model

WRF. It contains advanced and fast wind farm wake models, i.a. ForWind's further developed wake model FLAP. Moreover, a turbine load response database and electrical collection and grid connection models as well as wind farm control strategies are part of the toolbox whose IT infrastructure allows for an easy implementation of other models. The toolbox offers a user-friendly graphical interface and infrastructure that allows for linking all simulation outputs and presenting the simulated absolute and comparative costs.

An extensive offshore measurement campaign comprising load, met mast and nacelle-based LiDAR measurements aimed at providing data for model validation. Moreover, ECN's Active wake control concept has been tested for the first time in a real operating wind farm. It turned out that this control concept is especially useful in wind farms

with small distances between single wind turbines. With regards to the wind and stability atlas one of the major results was that according to the results obtained from WRF the atmosphere over the North Sea shows more often an unstable stratification than the atmosphere over the land. Sites with a high percentage of situations with unstable stratification might be favorable for the operation of wind farms as due to the faster recovery of wakes a better efficiency of the wind farm can be expected.

References

- [1] Woyte, A.: Final Report Summary - CLUSTERDESIGN (A Toolbox for Offshore Wind Farm Cluster Design), https://cordis.europa.eu/result/rcn/189357_en.html (2016)

RealMe – Traceable Acquisition of Meteorological Data

Universität Bremen
Bremen Institute for Metrology,
Automation and Quality Science (BIMAQ)

Michael Sorg

Funding: Federal Ministry for Economic
Affairs and Energy (BMWi)

Ref.Nr. ID: 0325468A

Duration: 09/2012 – 04/2016

Project Description

Anemometers and tail vanes are wind sensors, which are sensitive measuring instruments installed to acquire meteorological data to calculate the energy yield of wind turbines and wind farms. Various factors affect the acquisition and transmission of measurement data. Among them are the usual influences due to weather conditions but also incidents distort the measurement results. Thus, research partners from Ammonit Measurement, Adolf Thies, Deutsche Windguard and efm together with scientists of the University of Bremen initiated the research project in order to improve both the reliability and the accuracy of measured meteorological values.

Goal of the cooperative research project is to develop and enhance measuring systems for meteorological data. The results will increase reliability, security and trace-

ability of the measured data for evaluation by developers, operators of wind turbines and service providers. For compliance with enhanced quality-parameters, the sets of measurement-data in comprehension of all components of the measuring chain must be upgraded with digital signatures. This also prevents the manipulation of measured data which is required to ensure a correct assessment of the site's wind energy potential. Furthermore, for reasons of confidentiality the measured data must be encrypted. The partners evaluate appropriate methods to digitize, digitally sign, and encrypt measurement values directly in the sensor. Microelectronic circuits will be developed for the integration in meteorological sensors which are connected by digital bus-systems for secure data transfer (see fig. 1). The development of data plausibility checks requires additional sensors which will be added to the meteorological systems for detecting influences on data quality.

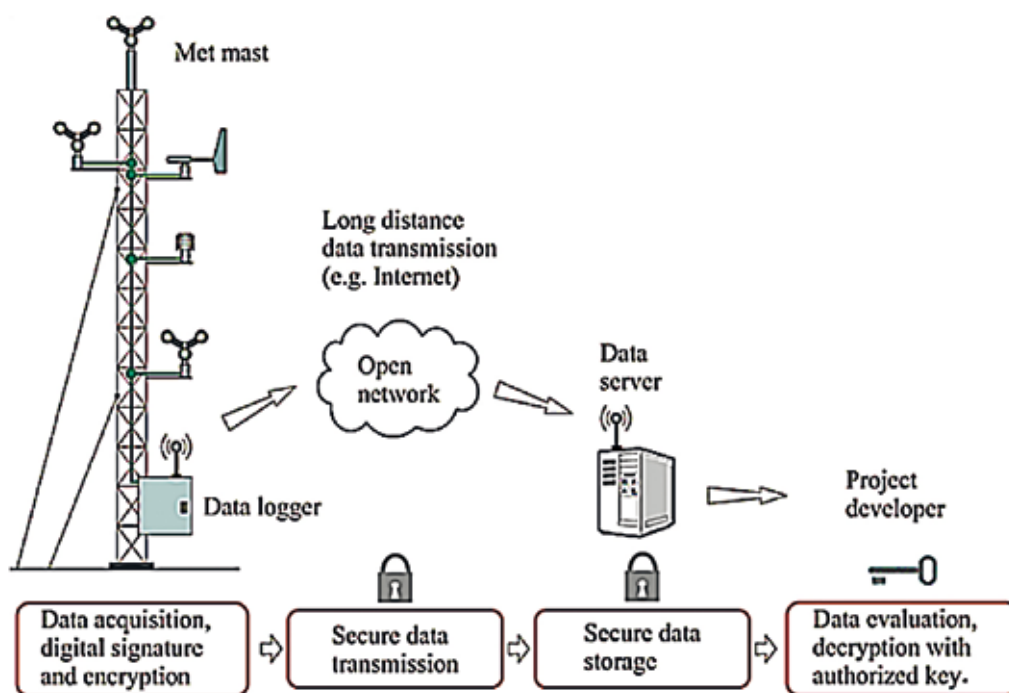

Figure 1: Acquisition of meteorological data with an extension of the data record with encryption and signature, and including all components of the measurement chain

WindScanner.eu – The European WindScanner Facility, Preparatory Phase

Carl von Ossietzky Universität Oldenburg
Institute of Physics,
Research Group: Wind Energy Systems

Partners:

- DTU, Denmark (coordinator)
- CENER-CIEMAT, Spain
- ECN, Netherlands
- CRES, Greece
- Fraunhofer IWES, Germany
- SINTEF, Norway
- LNEG/INETI, Portugal
- University of Porto, Portugal
- IPU, Denmark

Duration: 10/2012 - 09/2015

Introduction

The "WindScanner Facility" should provide a distributed research infrastructure (RI) consisting of advanced remote sensing devices for mainly wind energy applications. It would be established all over Europe as a new and innovative research facility. Included in the European Strategy Forum on Research Infrastructures (ES-FRI) for renewable energies in 2011, the "WindScanner Facility" should be able to provide new knowledge about detailed three-dimensional atmospheric wind flows leading in this way to an increased development of more efficient, stronger, smarter and lighter wind turbines.

Even though the main objective is wind energy research the WindScanner Facility is intended to be open for researchers and users from other disciplines as well.

The main objective of the new facility is to become a center of excellence formed by leading European research organizations.

The preparatory phase (PP) of the project dealt with all technical, legal, financial and administrative fundamentals required for the construction of the research infrastructure.

Project Description

The aim of the PP was to support the construction of the new WindScanner facility. Besides it integrates and upgrades already existing wind energy and wind turbine test centers as well as test sites in Europe. Due to the establishment of the new mobile and all over Europe distributed research infrastructure, it will be possible to coordinate and upgrade major European facilities with modern Lidar-WindScanners at the operational level enhancing in this way the European competitive advantage in wind energy systems.

The concept of the preparatory phase was the coordination of common European activities and European energy research organizations. The network was distributed between WindScanner research demonstration nodes and partners of the European Energy Research Alliance (EERA).

One of the major technical and economical tasks dealt with the equipment of highly trained personnel with mobile WindScanners.

Furthermore innovation generating activities, personal trainings and exchange programs should support the establishment of the facility.

Structure

The structure of the research infrastructure shall include the following elements: Expected are 6-8 associate partners with new WindScanners, designed and created during the preparatory phase, at already existing test facilities in Europe.

A large European-level coordinated experimental research programme would be based on wind energy measurement campaigns with key contributions from WindScanners.

Also a comprehensive database of wind data from potential wind energy sites would be made available to researchers, modelers, wind turbine manufacturers and wind energy developers.

The "WindScanner.eu hub" shall be set up in order to handle data flow and host servers and websites etc.

Objectives of the Preparatory Phase Project

The main objectives of the preparatory phase were:

- Establishment of the project management and logistics
- Development of a financial scheme
- Development and agreement on the legal framework required for the establishment and operation of the facility
- Draft planning of the scientific and technological work
- Realization of the implementation steps for the disseminated regional Wind-Scanners
- A joint planning for the regional expansion of WindScanner facilities

Summary

The research facility WindScanner.eu would consist of remote sensing measurement equipment and concepts based on portable and easy deployable wind lidars and wind scanners. The new measurement technology would be distributed and operated at European nodes and be connected by fast, scientific computer networks. The obtained results would lead to improved computer models on multiple scales of wind energy applications and allow an optimization of wind turbine designs from the blade to the whole wind farm. In conclusion, it would lead to better located as well as better wind turbines thus reducing the cost of renewable energy. The preparatory phase of the windscanner.eu facility project started in November 2012 and ended in 2015.

References

<http://www.windscanner.eu>.

European High-performance Infrastructures in Turbulence (EuHIT)

Carl von Ossietzky Universität Oldenburg
Institute of Physics

Research Group: Turbulence, Wind Energy
and Stochastics

Jaroslav Puczyłowski, Joachim Peinke,
Michael Hölling

Funding: European Community
Framework Programme 7

Ref.Nr. 312778

Duration: 04/2013 – 04/2017

Introduction

EuHIT was created as advances in key economical and societal issues facing Europe, like ground-, air- and sea-transport, energy generation and delivery, processing in chemical industries, marine biosphere management, climate change impact, atmospheric and marine pollution prediction, and carbon capture and storage processes are obstructed by the lack of understanding of turbulence. The reason lies in the fact that turbulent flows underlie all macroscopic natural and technological flows as soon as mass transport is large. In the past 10 years Europe has surpassed all other nations in research output and development of national infrastructures in turbulence research and its applications. However, due to a lack of European wide integration it has not reached its full potential for innovation in the sciences and technologies. EuHIT was thus born to overcome these limitations.

EuHIT is a consortium that aims at integrating cutting-edge European facilities for turbulence research across national bounda-

ries, in order to significantly advance the competitive edge of European turbulence research with special focus on providing the knowledge for technological innovation and for addressing grand societal challenges.

Current members of EuHIT include 25 research institutes and 2 industrial partners from 10 European countries. Total 14 cutting-edge turbulence research infrastructures, most of which are developed on national funds and are run by EuHIT member institutes, consist the material basis of EuHIT. A Networking Program and Joint Research Activities within EuHIT interconnect these infrastructures, together with the knowledge developed upon them.

The main components of EuHIT may be summarized briefly as:

Integration: Not only the research activities at the infrastructures, but also the training programs, the sharing of data, and the interaction with numerical modeling and theoretical analyses are all integrated under EuHIT. This facilitates access to the infrastructures and easy exchange of instruments, techniques, data, and new ideas.

Innovation: New techniques, algorithms, and next generation instruments are developed through Joint Research Activities (JRAs) to maintain the EuHIT infrastructures at the leading edge.

Dissemination: New tools and procedures are implemented to foster easy and open access to data and techniques developed from EuHIT, including the transfer of knowledge from academia to industries.

The University of Oldenburg successfully contributed in the EuHIT project by further developing the so-called 2D-LCA (2D-Laser Cantilever Anemometer), which is a new highly resolving anemometer particularly designed for turbulence research.

Project Description

The work package 19 includes new sensor developments and was processed by 3 partners within the EuHIT consortium (University of Oldenburg, SmartInst and Vision Research Europe B.V.). The task of the University of Oldenburg was to further improve the performance and reliability of the 2D-LCA. For this purpose some requirements were defined. In particular, the 2D-LCA should be able to operate on spatial scales of about 100 μm and at a frequency of up to 100 kHz and also become operable by inexperienced researchers.

Besides modifications to the structural components, new sensing elements (cantilevers) with increased directional sensitivity have been developed. In contrast to the previous cantilevers, the new designs have a "stepped" vane that is aerodynamically optimized and thus results in a better resolution of small angles of attack. Fig. 1 show the final design.

The conversion of the previous 2D-LCA to a more functional and user-friendly design has been concluded successfully. Fig. 2 shows the new design of the 2D-LCA. The main amendments to the previous version are the increased numbers of degrees of freedom (slide #10 for adjustment of the position sensitive detector (PSD) and mount #10 for position adjustment of the cantilever) and the laser beam guidance (detailed illustration in fig. 3). The adjustment possibilities allow the user to precisely align the laser onto the active area of the PSD. The modified laser path (see fig. 3) reduces ghosting by means of a thin beam splitter plate and therefore leads to an improved signal quality. Other modifications involve improved electronics, cable connections and the signal-processing unit.

In order to improve the mobility of the whole system a portable calibration unit has

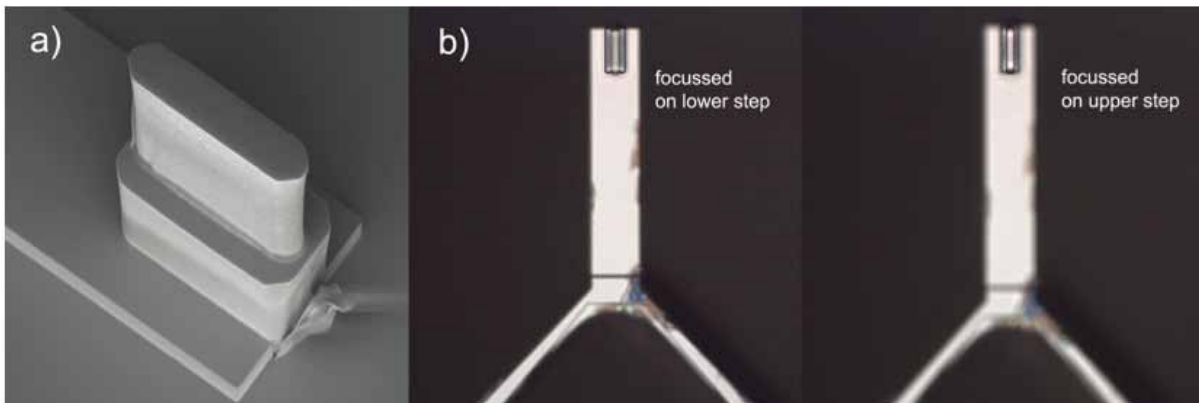

Figure 1: First realization of a cantilever with a "stepped" vane (a) and the final version (b)

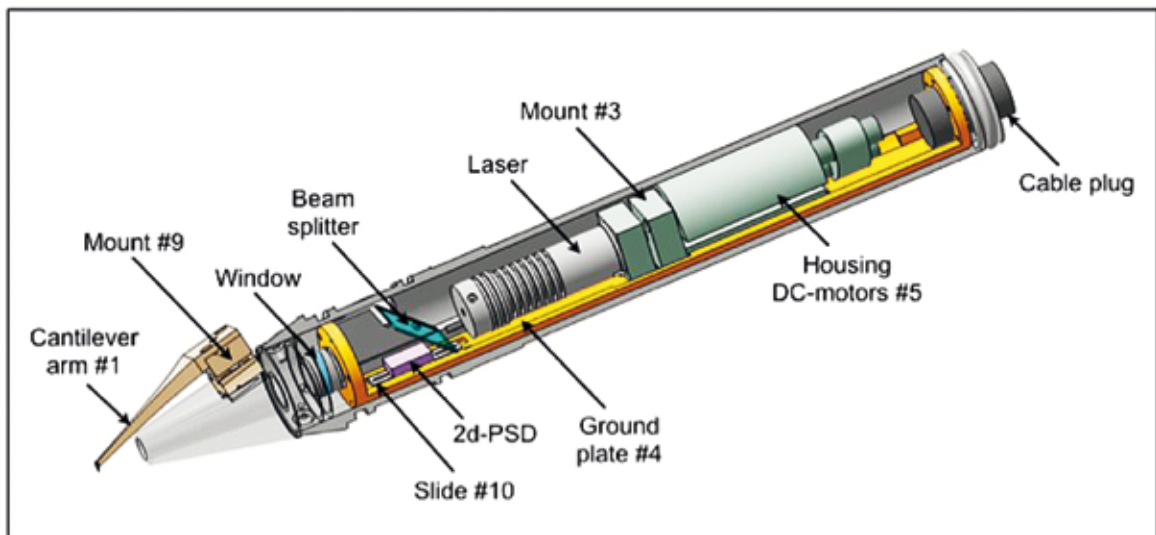

Figure 2: Design of the 2D-LCA

been designed but not yet fully tested. In addition, based on the design of new cantilevers further cantilevers for other velocity ranges were manufactured and tested.

Summary

Within the Euhit project the further development of the 2D-LCA could be advanced considerably. The biggest achievement was the development of the cantilever, which significantly increases the performance of the sensor. Further design improvements, which led to easier handling and better signal quality, were also successfully implemented.

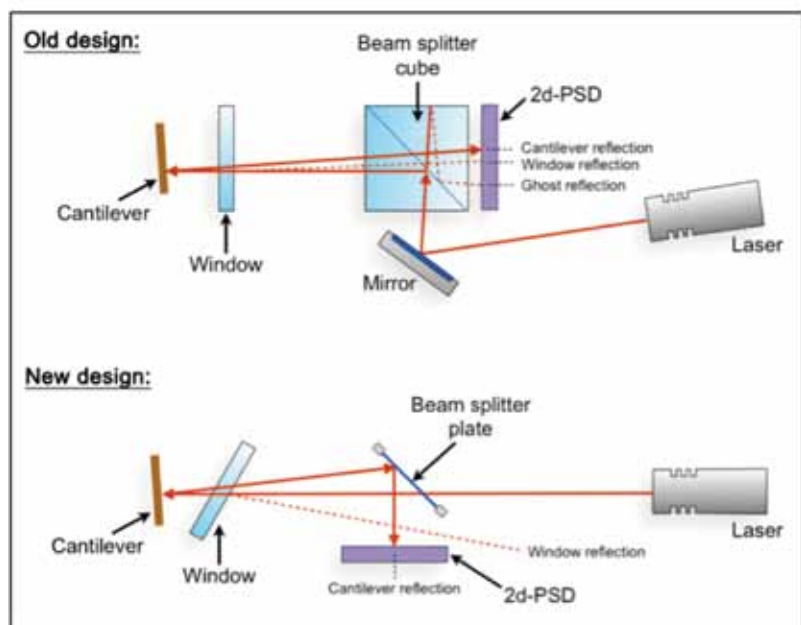

Figure 3: Design of the laser beam guidance.

PhD Programme on "System Integration of Renewable Energies"

Carl von Ossietzky Universität Oldenburg
Institute of Physics,
Research Group: Wind Energy Systems

Martin Kühn (Supervisor)
Mehdi Vali (Candidate)

PhD project title: Wind farm control
framework for performance optimization
with respect to dynamic flow conditions

Funding: Ministry for Sciences and
Culture of the Federal State of Lower
Saxony

Duration: 12/2013 – 12/2016

Introduction

Control of turbines in a wind farm is challenging because of the aerodynamic interactions via wakes. The characteristics of a wake are reduced wind speed and increased turbulence. The former reduces the total power production of the farm and the latter leads to a higher dynamic loading on the downstream turbines. In today commercial wind farms, wind turbines are regulated greedy. By changing operating points of upwind turbines, it is possible to influence the wake interactions, and thus the performance of downwind turbines, possibly increasing overall power capture or decreasing structural fatigue loads. Therefore, wind farm control has recently received significant attention to lower the levelized cost of energy [1]. The inherent modeling uncertainties and time-varying inflow conditions, e.g., turbulent nature of wind, wind direction changes, and wake meandering demand for a closed-loop control approach to react fast enough against sources of the wake interactions within a wind farm.

Project Description

A joint research cooperation is established with Delft Center of Systems and Control (DCSC), TU Delft for investigating the closed-loop wind farm control in order to minimize the undesirable effects of wake interactions. Fig. 1 depicts the control architecture of our investigated optimal control framework for waked wind farms, consisting of the following four main elements:

- 1) a simplified model of wind farm to capture the dominant waked inflow dynamics [2],
- 2) an adjoint-based model predictive control (AMPC) to optimally adjust the wind turbines degrees of freedom, e.g., the axial induction factor and yaw angle [3], [4],
- 3) a state observer for flow field estimation against uncertainties and mismatches [5],
- 4) a large-eddy simulation (LES) model of the wind farm in order to test the perfor-

mance and realization of the designed controller, under detailed time-varying interactions with boundary layer [6].

Adjoint-based model predictive control (AMPC)

The idea to maximize the power production of wind farms in the presence of wakes is to coordinate the control settings of individual turbines, by taking their wake interactions into account. Furthermore, in order to balance power supply with demand, a wind farm plant should respond to grid requirements through control of its power production, the so-called active power control (APC). The non-unique solution of APC for wind farms is a resulting by-product which can be exploited for optimal power/load distributions among the wind turbines.

A model predictive control (MPC) has been developed in order to optimally control of wakes interactions with time-varying atmospheric and operational condi-

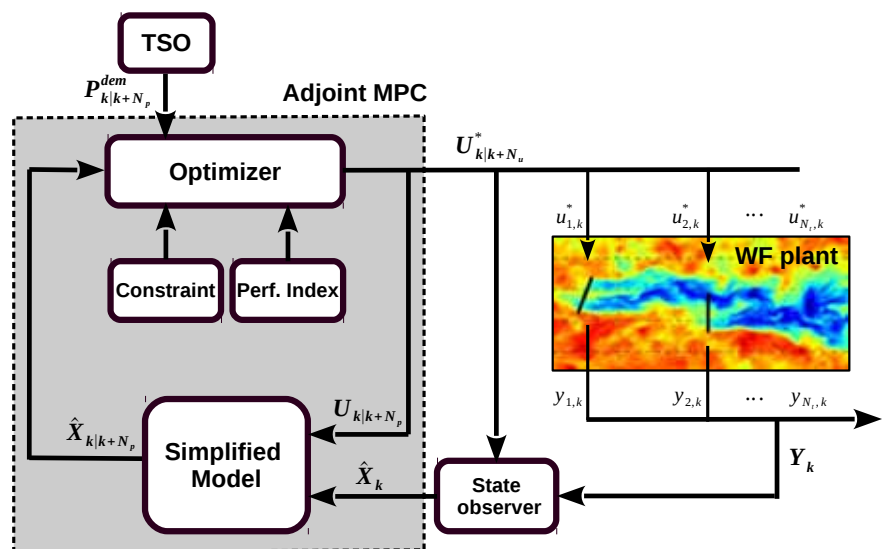

Figure 1: Schematic illustration of the closed-loop optimal control of wind farms. The grey block contains the main components of the adjoint-based model predictive control (AMPC).

tions. It relies on a 2D dynamic wind farm model, the so-called WFSim [2], which predicts the dominant inflows and wake interactions in a reasonably computationally inexpensive manner. A constrained optimization problem is formulated with respect to the wind turbines control inputs. The systematic structure of the optimal control problem allows us to consider it for different wind farm control objectives. An adjoint approach is developed as a cost-effective tool to compute the gradient of the

performance of interest, subjected to disturbances and uncertainties, with the same computational cost of the model. Indeed, adjoint variable associates the variations of the model and the cost function [3],[4].

Investigation of concepts

For practical perspectives of the approach, it is demonstrated that WFSim is able to capture the dominant dynamics of the re-solved turbulent wakes of the PARallelized Large-eddy simulation Model (PALM) of

wind farms. Fig. 2 plots the instantaneous fields of the u-components of the wind at hub height of the wind turbines simulated with both models. The total power production of the wind farm and the wake impacts are well estimated using WFSim, which is a medium-fidelity wind farm model developed for closed-loop control of wind farms [2].

Fig. 3 demonstrates the performance of the adjoint MPC for power maximization and

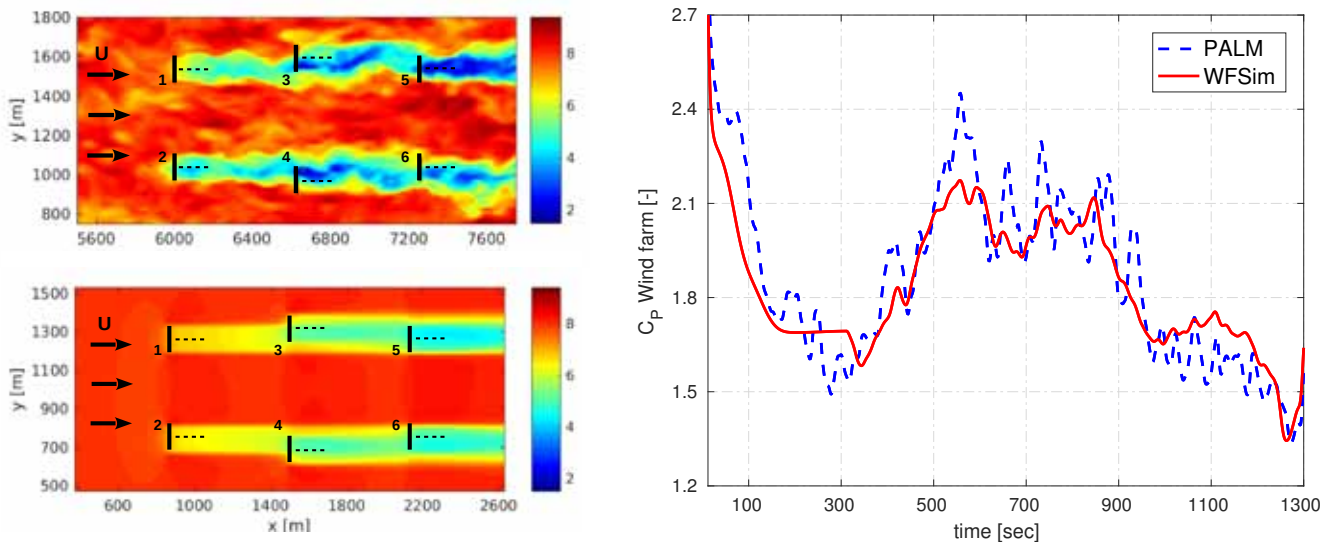

Figure 2: (left) The layout of the 2x3 wind farm example simulated with PALM (upper) and WFSim (lower). (right) The total power coefficient of the wind farm simulated with WFSim, compared with PALM.

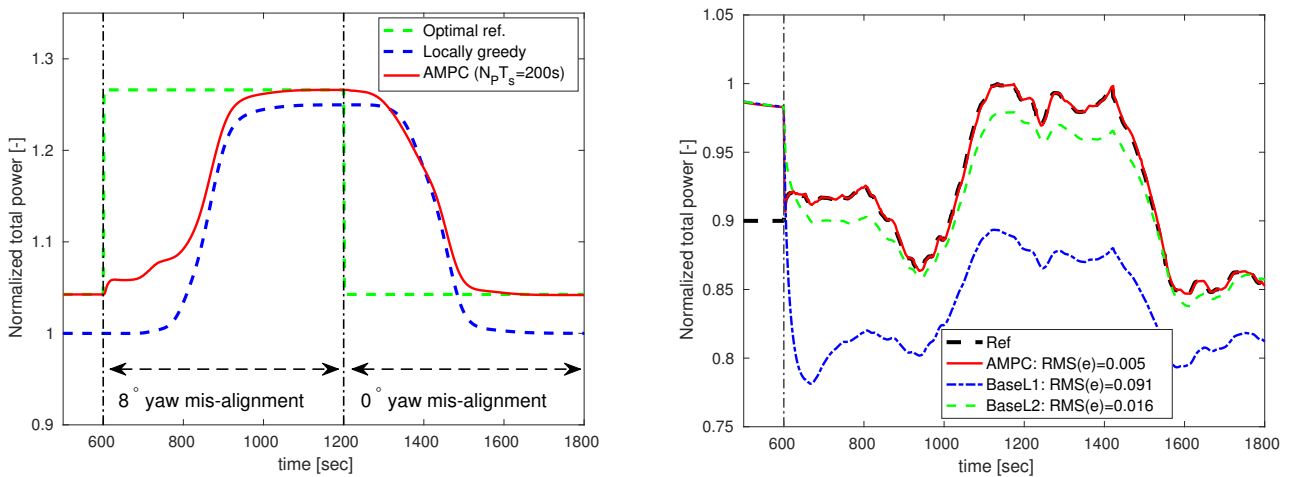

Figure 3: AMPC performance for optimal control of the waked wind farm. (left) The maximized power production when wind direction changes. (right) Active power control for tracking a power reference demanded by the TSO.

providing active power services of waked wind farms for optimally adjusting the wind turbine control inputs in order to realize wind farm control objectives, subjected to time varying atmospheric and operational conditions. The left plot compares the performance of the AMPC with the locally greedy control with dynamic changes in wind direction. The AMPC adjusts the wind turbine control inputs to the corresponding optimal settings using feedbacks and thus the wind farm operates at optimal points. The right plot illustrates the capability of the AMPC for optimally power distributing among the individual wind turbines while their total power productions follow a time-varying power reference, demanded by the TSO (transmission system operator). Contrary to the baseline cases, including a central open-loop control system with two different power set-point distributions, the AMPC improves significantly the RMS (root mean square) of the power tracking error using feedbacks.

Summary

An adjoint-based model predictive control (AMPC) has been developed for optimal energy extraction of wind farms, considering the aerodynamic wake interactions. The closed-loop wind farm control framework relies on a medium fidelity wind farm model, the so-called WFSim, to predict the dominant wake dynamics in an inexpensive computational manner. AMPC benefits from an adjoint approach as a computationally-efficient tool for computing the gradient. Both features are computationally desirable for real-time control implementations. The accuracy and reliability of the model for computing the optimal trajectories are validated using an LES model of wind farm. The systematic formulation of the optimal control problem make the AMPC compatible for different control objectives of waked wind farms, e.g., power maximization, active power control, and optimal load distribution.

References

- [1] Knudsen, T.; Bak, T.; Svenstrup, M.: Survey of wind farm control-power and fatigue optimization. *Wind Energ.*, 18: pp. 1333–1351. (2015)
- [2] Boersma, S.; Doekemeijer, B.; Vali, M.; Meyers, J.; van Wingerden, J.-W.: A control-oriented dynamic wind farm model: WFSim, *Wind Energy Science* 3 (1) pp. 75-95 (2018).
- [3] Vali, M.; Petrovic, V.; Boersma, S.; van Wingerden, J.-W.; Kühn, M.: Adjoint-based model predictive control of wind farms: Beyond the quasi steady-state power maximization, in *IFAC-PapersOnLine*, vol. 50, no. 1, pp. 4510-4515, July 2017.
- [4] Vali, M.; Petrovic, V.; Boersma, S.; van Wingerden, J.-W.; L.Y. Pao; Kühn, M.: Model predictive active power control of waked wind farms, in *American Control Conference*, pp. 707-714, June 2018.
- [5] Doekemeijer, B.; Boersma, S.; L.Y. Pao; van Wingerden, J.-W.: Ensemble Kalman filtering for wind field estimation in wind farms, in *American Control Conference*, pp. 19-24, May 2017.
- [6] Vali, M.; Vollmer, L.; Petrovic, V.; Kühn, M.: A closed-loop wind farm control framework for maximization of wind farm power production, in *1st Wind Energy Science Conference (WESC2017)*, June 2017.

Turbulence Resolving Simulations for Meteorological Assessment of Wind Energy Sites in Complex Terrain

Leibniz Universität Hannover
Institute of Meteorology and Climatology,
PALM research group

Lennart Böske, Christoph Knigge, Siegfried Raasch

Funding: Federal Ministry for Economic Affairs and Energy (BMWi)

Ref.Nr. 0325719C

Duration: 11/2014 – 10/2017

Introduction

The project is part of a larger joint research project coordinated by the German wind turbine manufacturer ENERCON. The main goal is to further develop new high resolution simulation techniques from basic and academic research in order to apply them for load and power forecasts of wind turbines in complex terrain. The turbulent wind field is simulated with the large-eddy simulation (LES) technique, where the large, main energy containing eddies are explicitly resolved by the numerical grid, while only the small scale turbulence is parameterized. The numerical solver is

tested in an industrial environment for real complex terrains, including vegetation and steep topologies, and is validated with field measurements from existing wind turbine sites. One major goal is to demonstrate the applicability of the simulation tool in an industrial environment.

Project Description

Wind energy sites in complex terrain are often exposed to very turbulent atmospheric flow fields which generate heavy mechanical loads on the rotor blades. The rapidly changing loads may significantly reduce



Figure 1: Wind energy site in complex terrain (Source: Courtesy of ENERCON, Germany)

lifetime of the systems. Current simulation techniques used for site assessment studies (Reynolds-Averaged Navier-Stokes models, RANS) only predict the mean flow features and can not account for turbulent fluctuations. Therefore, the project aims to apply an LES model for simulating the turbulent atmospheric boundary layer flow above complex terrain with very high spatial resolution down to a few meters. The high resolution data are used by project partners from the University of Stuttgart (Institut für Aerodynamik und Gasdynamik, IAG) and the DLR Braunschweig (Institut für Aerodynamik und Strömungstechnik) as input to engineering CFD models which calculate the near field flow around the blades in order to determine mechanical loads.

Because of its high computational demands, the LES technique has been used mainly for basic research in the past, but the rapidly increasing power of computer systems nowadays allow to use it also for applied industrial applications. The PARallelized LES Model PALM [1] is the central tool for simulating the atmospheric turbulence in this project. It has been developed at IMUK, has a very high computational performance and is highly optimized to be used on massively parallel computer architectures. Such computer clusters are meanwhile operated even by medium-sized companies, demonstrating that LES has or will become an option e.g. for site assessment studies.

The PALM code is also used by other For-Wind partners, mainly at the University of Oldenburg (Institute of Physics, Research Group Energy Meteorology).

The project has been finished in October 2017. Model results for simple idealized topographies (e.g. Gaussian hills) have been compared and validated with wind tunnel data. Final simulations have been carried out for existing sites with very complex topography like shown in Figure 1 and compared with field measurement data. It has been demonstrated that LES can be applied operationally for site assessment studies. Therefore, sensitivity studies have been done in order to determine optimum values, e.g. for the computational domain size and

grid spacing, that minimize the computational demands of the simulations but guarantee sufficient accuracy of the results.

Summary

The project aimed to demonstrate that turbulence resolving simulations of atmospheric flows are ready to be used for operational site assessment studies in complex terrain. High resolution simulations have been carried out with the LES model PALM for existing sites and compared with field observations.

References

- [1] Maronga, B., Gryschka, M., Heinze, R., Hoffmann, F., Kanani-Sühring, F., Keck, M., Ketelsen, K., Letzel, M. O., Sühring, M., and S. Raasch (2015): The Parallelized Large-Eddy Simulation Model (PALM) version 4.0 for Atmospheric and Oceanic Flows: Model Formulation, Recent Developments, and Future Perspectives, *Geosci. Model Dev. Discuss.*, 8, 1539-1637 DOI: 10.5194/gmdd-8-1539-2015

German Research Facility for Wind Energy (DFWind)

Carl von Ossietzky Universität Oldenburg
Institute of Physics,
Research Group: Wind Energy systems
(WESys),
Research Group: Energy Meteorology
(EnMet),
Research Group: Turbulence, Wind Energy
and Stochastics (TWiSt)

Martin Kühn, Detlev Heinemann,
Joachim Peinke, Martin Kraft,
Gerald Steinfeld, Michael Hölling,
Vlaho Petrovic, Dominik Traphan,
Abdulkarim Abdulrazek,
Agnieszka Hölling, Tim Homeyer,
Hauke Wurps, Agnieszka Hölling,
Leo Höning, Dominik Traphan,
Luis Vera-Tudela, Janna Seifert,
Marijn van Dooren, Róbert Ungurán

Funding: Federal Ministry for Economic
Affairs and Energy (BMWi)

Ref.Nr. 0325936C

Duration: 01/2016 – 12/2020

Introduction

DFWind is a joint research project that is coordinated by the German Aerospace Center (DLR). Besides Carl von Ossietzky Universität Oldenburg (ForWind-OL) the further partners in the project are Leibniz Universität Hannover (ForWind-H), Universität Bremen (ForWind-HB) as well as the Fraunhofer Institute for Wind Energy and Energy System Technology (IWES).

The objective of phase 1 of the project is to deliver the basic infrastructure at the research wind farm that is funded by the German federal state of Lower Saxony in PROwind project. DFWind will include additional equipment such as sensors or a data management system that is required

to do research in the two multi-MW wind turbines in the windfarm. Moreover, phase 1 of the project aims at preparing the installation and the instrumentation of the two wind turbines. Another objective of phase 1 is the execution of meteorological measurements in order to get an information on the flow conditions at the site of the wind farm before the installation of the two wind turbines.

Project Description

The contributions of ForWind-OL to DFWind can be attributed to the field of wind physics. The researchers from Oldenburg are aiming at providing the necessary measurement facilities that are required to get an improved understanding of the turbulent flow in the atmospheric boundary layer as well as the aerodynamic loads felt by the wind turbines. The objective is to obtain data with an unprecedented degree of spatial and temporal resolution. Another goal of the researchers at ForWind-OL is the development of new control methods of the wind farm with the aim to reduce loads, increase power output and reliability of wind turbines. These methods shall in later projects be tested on the wind turbines in the research wind farm.

The main objectives of the subproject of ForWind-OL in phase 1 of DFWind can be summarized as follows:

1. The development of a concept and partial implementation of infrastructure for measurements of the meteorological ambient conditions in the wind farm with high spatial and temporal resolution.
2. First steps towards the development of an aerodynamic measurement system for the local inflow, the circulation and the wake of rotor blade segments delivering data with high resolution.

3. First steps toward the development of a soft- and hardware platform for testing of experimental control concepts for wind turbines and wind farms that might be relevant to security.
4. The further development of monitoring methods for wind turbines during measurement campaigns with changed operational parameters.
5. The specification of a data acquisition and a data management system for the utilization in the research wind farm.

Phase 1 of DFWind is structured in five work packages. Work package AP0 comprises the coordination activities for the whole project as well as for the four scientific work packages. Work package AP1 deals with the complete wind turbine, while work package AP2 aims at implementing the instrumentation that is required for meteorological and acoustic measurements at the site of the wind farm. Work package AP3 deals with the preparation of measurement technique for the rotor blade, while work package AP4 aims at preparing the research wind farm for research concerning the supporting structure and geotechnics. ForWind-OL is involved in the coordination work package as well as the first three scientific work packages of the project.

The following paragraphs summarize the major contributions by ForWind-OL to the DFWind project in the years 2016 and 2017.

WESys:

In AP1 WESys supports DLR in the development of an "Advanced Protection System" which shall assure the safe operation of experimental plant controllers. WESys develops a LiDAR-based system to measure the inflow wind speed for real-time prognosis of the transient loads. For this purpose, the use of a continuous-wave LiDAR system, the so-called Spinner-LiDAR is planned. It is placed in the wind turbine in the rotating spinner. The system



Figure 1: Free field test of short-range LiDAR System on top of Nacelle wind turbine AV04

measures the incoming wind on a spherical surface at a focal distance of 10-150 m at an opening angle of $\pm 30^\circ$ in a temporal resolution of 400 points per second. First models for forecasting the incoming wind field were created. The "Spinner-LiDAR" was successfully tested on the nacelle roof on AV04 in the Alpha Ventus offshore wind farm as well as in the rotating spinner of an eno114 plant in the Brusow wind farm in open field trials. In comparison, the clearly superior information content was shown when placing the device in the rotating spinner with a clear view to the front (see fig. 1).

For the research wind turbines in the DFWind project, knowledge of the fatigue loads sustained is relevant. The knowledge is required regardless of currently available or possibly disturbed sensors. To ensure a reliable determination of the fatigue loads, investigations were carried out with 10-minute Supervisory Control and Data

Acquisition (SCADA) data from two wind turbines from the Baltic I wind farm. Neural networks were designed to estimate the fatigue loads on the blade root. The most suitable input variables for the estimation, i.e. the most important statistical values of different sensors were identified. Depending on the location, wake situation or free flow, the selection of the most suitable signals was different. A generic model was created, considering both wind turbines. Subsequently, the selection was updated in case of failure of individual sensors or the lack of individual statistics. The results showed that no additional statistics were chosen to replace the missing sensor case, while single missing statistics were replaced by their closest complements. In both cases a comparably good estimation accuracy was achieved. This leads to the conclusion that, for an accurate load estimate, no additional signals are needed besides the ones chosen. For normal operating conditions, the use of standard signals

is enough to allow predicting the fatigue loads of a wind turbine.

In AP2 WESys is responsible for the measurement of the near rotor inflow and downflow around the research turbines with relevant temporal and spatial resolution with LiDAR systems. Two coordinated ground based continuous-wave short-range LiDARs (WindScanner) will measure the wind vectors with high resolution due to the 5" prism of the systems. A first WindScanner has already been delivered by Danish Technical University. It has been tested in the large wind tunnel of FW-OL in November / December 2017 with a focus distance of approx. 30 m and showed already a good resolution. [1-4].

EnMet:

In AP1 the Energy Meteorology group was involved in the process of defining the requirements for the data management system for the research wind farm. The data

management system must fulfil two main tasks: Collecting all the measured data from the wind farm and making the data available to users that have the permission to access the data. The main contribution of the Energy Meteorology group was the preparation and evaluation of a survey in which the future users of the research wind farm were asked for their preferences and requirements concerning the data management system. Moreover, staff from the Energy Meteorology group accompanied the process of the acquisition of a data management system as a representative for the future users of that system by taking part in regular meetings with the provider of that data management system during the implementation phase. Furthermore, staff from the Energy Meteorology group collected data from sensors that were already available at the project partners in order to provide it for early tests of the data management system.

In AP2 a major contribution of the Energy Meteorology group was to develop a plan for the measurements and the layout of the IECplus met mast.

Moreover, several sensors have been bought and put into operation in the laboratory during the first two years of the project. Two eddy-covariance systems have extensively been used during a measurement campaign at the site of a wind farm in Northern Germany. The objective of these measurements was to gain information on atmospheric stability at the site in order to analyse the dependency of the wind turbine behaviour from atmospheric stability. A major outcome of the work with the data from the eddy covariance stations at the wind farm in Northern Germany was the development of a postprocessing procedure for eddy covariance data that will further be used in the course of the DFWind project.

TWiSt:

Within DFWind, the research group TWiSt is in AP2 responsible for the conceptual design of the so-called met-mast array positioned between the two wind turbines at the research facility. The array will allow for measuring the wind field with high spatial and temporal resolution in either the wake of the one turbine or the free incom-

ing wind field for the other wind turbine. The arrangement of three met masts is in such a way that the booms span a plane in which the anemometers are located. The individual positions and the distance between the cup- and ultrasonic-anemometers should cover a wide range of scales in order to be able to investigate e.g. correlations within the wind field. Data analysis of free field measurements of an offshore met mast shows that flow structures up to a few hundred meters are self-similar. This implies that anemometers do not have to cover the area with the highest possible spatial resolution but can be positioned in a non-equidistant manner without losing information. Fig. 3 shows a sketch of the three met masts with calculated positions for the anemometers. In this concept the non-equidistant distribution is applied in the vertical and horizontal direction for a few rows, and columns respectively. A regular grid-distribution has also been added in order to provide data that can be easily used for computer simulations. Besides the conceptual design of the met-mast array TWiSt investigated possible boundary conditions that might influence the measurements at

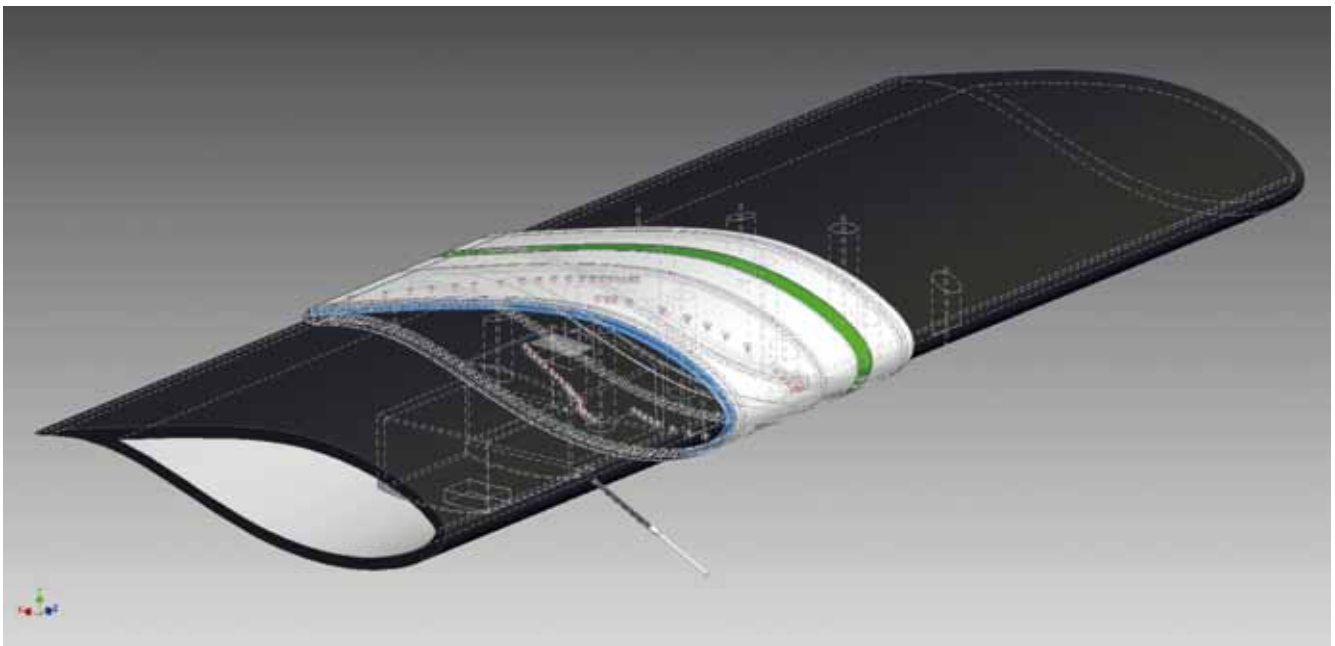

Figure 2: CAD technical drawing of a rotor blade segment with the aerodynamic glove (gray). The pressure taps are located in the green stripe where the microphones are distributed left of them. The 5-hole probe is located outside of the glove and will be mounted at a hard point on the blade directly.

the array e.g. blockage of the wind turbine located in the wake of the array. This topic was addressed in computer simulation as well as in wind tunnel experiments.

Knowledge of the local aerodynamic at the rotating rotor blade is very important in order to better understand the complete performance of the wind turbine. In AP3 Computer simulations are based on models that try to capture aerodynamic effect that can occur on rotor blades. For validating these models, the local inflow conditions as well as the flow around the blade need to be measured in the rotating system in the free field. Therefore, in AP3 TWiSt in co-

operation with the DLR in Braunschweig is involved in the design and development of an aerodynamic glove allowing measuring the local flow conditions. Fig. 2 shows a technical drawing with the basic design of the glove and the position of the different sensors. Here, the 5-hole probe will measure the local flow velocity as well as the local angle of attack for the blade segment. Pressure taps in the green belt can measure the absolute pressure distributed along the span of the profile where additional microphones will give access to the fluctuations to identify e.g. flow separation.

Summary

Within the DFWind project ForWind Oldenburg cooperates with partners to develop an infrastructure that help researches to better understand the physics of wind. In the first years of the project main components have been defined. This includes the unique characteristic met mast to measure the met mast array with several masts that will measure the turbulent wind field with high accuracy as well as the equipment to characterize the atmospheric stability. The methods to use the measuring devices have been improved. Some components could already be delivered, as the first 5" cw-WindScanner, and tested in free field as the cw-Spinner-LiDAR.

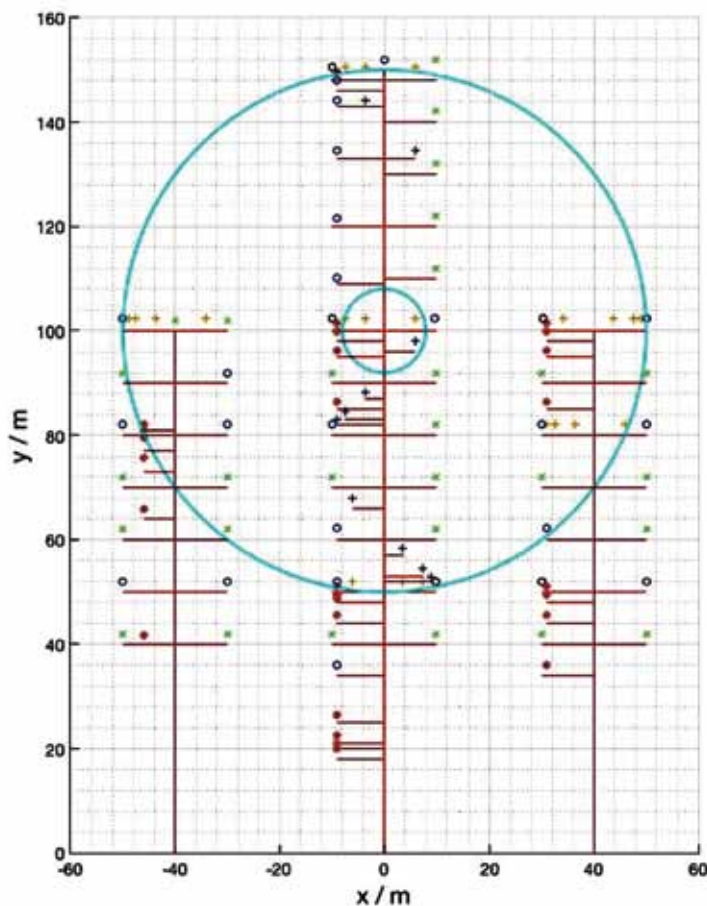

Figure 3: Sketch of met-mast array with three masts. The large circle represents the swept area of the wind turbines at the research facility. The colored symbols represent possible anemometer positions based on the calculations performed.

References

- [1] van Dooren, M. et al., Demonstration of synchronised scanning Lidar measurements of 2D velocity fields in a boundary-layer wind tunnel, in *Journal of Physics: Conference Series*, 2016, vol. 753, no. 7, p. 072032: IOP Publishing.
- [2] Seifert, J.; Vera-Tudela, L.; Kühn, M.: Training requirements of a neural network used for fatigue load estimation of offshore wind turbines, *Energy Procedia*, vol. 137, pp. 315-322, 2017/10/01/ 2017.
- [3] Vera-Tudela, L.; Kraft, M.; Kühn, M.: How do missing data affect your data-driven model? Monitoring fatigue loads with SCADA, presented at the *Offshore Windenergy 2017*, London, UK, 2017.
- [4] Vera-Tudela L.; Kühn, M.: Analysing wind turbine fatigue load prediction: The impact of wind farm flow conditions, *Renewable Energy*, 2017.

NEWA – New European Wind Atlas Joint Programme

Carl von Ossietzky Universität Oldenburg
Research group: Wind Energy
Meteorology

Björn Witha, Gerald Steinfeld, Stephan
Voss, Jörg Schneemann

Partners: 30 institutions from 8 countries
(Belgium, Denmark, Germany, Latvia,
Portugal, Spain, Sweden, Turkey),
coordinator: Technical University of
Denmark (DTU)

Funding: Federal Ministry for Economic
Affairs and Energy (BMWi)

Ref.Nr. 0325832B

Duration: 03/2015 – 02/2019

Introduction

The New European Wind Atlas (NEWA[1, 2]) Project is funded under the European Commission's 7th Framework Programme ERA-Net Plus that comprises nine funding agencies from eight EU Member States. The project aims to create a new and detailed European wind resource atlas, as well as collecting data from field experiments to generate a high-fidelity database of wind characteristics. The NEWA project is developing a new reference methodology for wind resource assessment and wind turbine site suitability based on a mesoscale-to-microscale model-chain. This new methodology will produce a more reliable wind characterization than current models, leading to a significant reduction of uncertainties on wind energy production and wind conditions that affect the design of wind turbines.

The overall objectives of NEWA are:

- To develop a high-value data base of high-fidelity experiments.
- To develop methodologies for wind resource assessment and wind turbine site

suitability based on a mesoscale to microscale model chain.

- To create and publish a European Wind Atlas database publicly accessible through a web interface. It will include a high-resolution mesoscale wind atlas (3 km), as base of a microscale wind atlas (50 m) and joint associated uncertainties.
- To define a verification and validation framework for the model-chain based on the experimental campaigns and means to quantify the uncertainties of the wind atlas.

The last effort of a European wide wind atlas was conducted almost 30 years ago [3]. The region covered by this atlas is smaller, the spatial resolution is lower and additionally, no mesoscale models were used for

its development. Thus, an updated version with state-of-the-art mesoscale models, parameterization schemes and uncertainty quantifications build a solid foundation for the successful subsequent application of the microscale downscaling. All this makes the New European Wind Atlas an invaluable product for the wind energy industry, more so in the context of a shift in the energy production paradigm aimed to comply with the Paris agreements. The information provided by this new atlas is necessary for a realistic planning phase of wind energy development, which can last several years from strategic spatial planning, to site prospecting, to wind farm design and financing. Detailed and robust information about the wind resource across an area is crucial for the commercial evaluation of a wind farm [4].



Figure 1: Spatial coverage of the New European Wind Atlas, covering the EU, Turkey, Norway and extending 100 km offshore. The location of high fidelity experiments are indicated by red dots and a line for a ferry-based profiling transect in the Baltic Sea. Participating countries in the ERA-Net Plus project are in green: Belgium, Denmark, Germany, Latvia, Portugal, Spain, Sweden and Turkey.

Project Description

The project is divided into three main work packages covering the field experiments, the development of a model chain and the wind atlas database.

Field experiments

Within the NEWA project a number of full-scale field experiments have been prepared and executed [5]. These include measurement campaigns over complex terrain as well as over flat terrain and offshore. ForWind has been involved in three of these experiments. Data from the experiments will be released in a publicly accessible database.

The *Kassel forested hill experiment* took place between October 2016 and January 2017 with accompanying long-term measurements from two tall met masts (140 m and 200 m) between November 2016 and October 2017. During the extensive campaign 9 long-range Doppler scanning lidars and 6 vertical wind profilers (2 lidars, 4 sodars) were installed on a forested hill site (Rödese Berg) near Kassel. ForWind contributed with two scanning lidars. The experiment was optimized to measure the flow along the main wind direction (SW towards NE) over the hill.

The *Perdigao experiment* is by far the largest of the NEWA experiments [6]. Altogether 55 met masts (between 2 m and 100 m height), 22 scanning lidars, 7 profiling lidars and several further instruments including radiosondes, radars and sodars have been installed on the site, a nearly perfectly aligned double ridge, in central Portugal. ForWind contributed with two scanning lidars. During 7 months, between December 2016 and July 2017, they have been measuring the flow over the double ridge.

In the *FerryLidar experiment* a Doppler lidar was placed on a ferry boat travelling on a regular route through the southern Baltic Sea between Kiel (Germany) and Klaipeda (Lithuania). Between February and June 2017 the vertical profile of the marine atmospheric boundary layer (meas-

uring heights between 65 m and 275 m) in the Southern Baltic was measured. While mainly conducted by our project partner Fraunhofer IWES, ForWind was involved in the planning of the experiment and in the discussion of the results.

Further experiments conducted during NEWA but without contribution from ForWind:

- RUNE: measuring the near shore flow with scanning lidars at Danish west coast
- Østerild: Measuring the flow in hub height over flat terrain in Northern Denmark with two horizontally scanning lidars mounted on tall masts
- Hornamossen: Measuring the flow over undulating, forested terrain in Sweden with a 180 m met mast, ceilometers, lidar profilers and sodars
- Alaiz: Flow over very complex terrain in Northern Spain

Model chain

The NEWA model chain consists of two parts: the mesoscale model WRF and the microscale CFD model based on OpenFOAM. The NEWA model chain will be open to the public domain and serve as a

reference flow model that can link mesoscale and microscale wind climate conditions consistently.

ForWind is significantly involved in the preparation and implementation of the mesoscale wind atlas. Extensive studies with the mesoscale model WRF have been performed in which different parameter and model settings have been tested and compared. The primary goal of these tests is to find an optimal setup for the wind atlas production runs.

A further main task in NEWA is to develop a probabilistic wind atlas which shall add uncertainty information to NEWA. A key component of the probabilistic wind atlas is a multi-physics ensemble of WRF model runs with different parameter settings, e.g. different parameterizations of the atmospheric boundary layer and different forcing data.

To be able to assess the quality of certain model runs, it is inevitable to compare the simulated results to measurements. For this purpose data from tall met masts (50 m – 300 m height) was collected. An example of such a comparison to measurement data can be seen in Fig. 2.

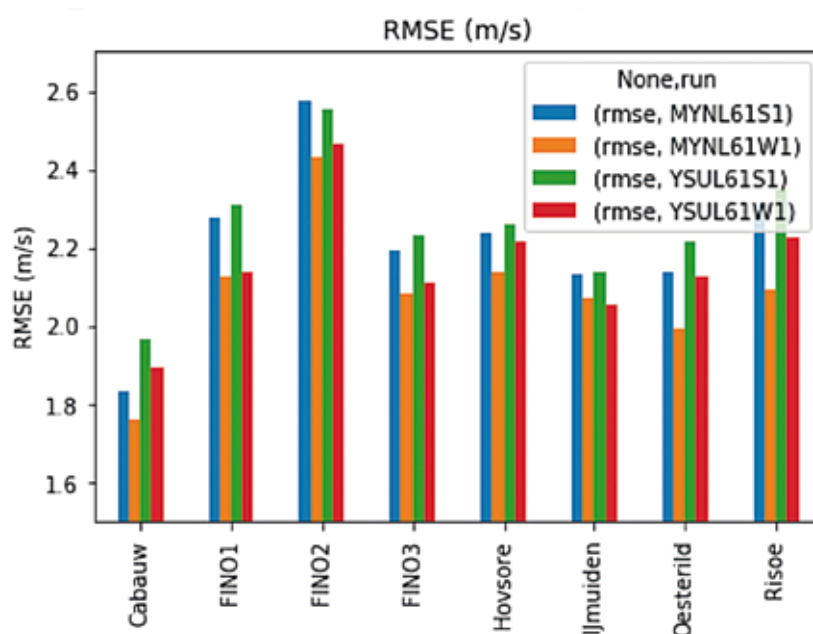

Figure 2: Comparison of simulated WRF data to measurement data for several stations. Courtesy of A. Hahmann (DTU)

A further task was to implement the analog ensemble method, previously used for wind forecasting, for wind resource assessment following the method of Vanvyve et al. (2015)[7]. It is planned to use the analog ensemble for the quantification of uncertainties in the mesoscale modelling.

In the microscale modelling part of this work package, ForWind has participated in the Ryningsnäs benchmark with the LES model PALM. A forested site in Sweden was simulated and compared with measurements.

Wind atlas database

A survey on stakeholders' expectations to NEWA has been conducted among potential end-users in the wind energy community. Based on the results of this survey, the final output parameters for the wind atlas have been defined.

The mesoscale wind atlas will include time series of several quantities (e.g. wind speed and direction, temperature, atmospheric

stability, wind power) in several heights between 50 and 500 m as well as statistical properties (e.g. wind speed distribution, wind rose) for each location in Europe on a 3 km x 3 km grid.

The microscale wind atlas will display the statistical properties on a 50 m x 50 m grid. The wind atlas will be open to the public. End-users can view some of the data via a web-interface and select data to be downloaded from the NEWA database.

Various domain configurations for the mesoscale wind atlas have been tested, and finally 10 domains over Europe have been defined (see Fig. 3).

For the final production runs and the multi-physics ensemble an application requesting computing resources to the amount of 56 Mill. CPU hours has been submitted to the PRACE consortium (Partnership for Advanced Computing in Europe) to be spent on the MareNostrum supercomputer in Barcelona.

Summary

A New European Wind Atlas (NEWA) is being generated, open to the public and based on mesoscale simulations with 3 km resolution which are statistically down-scaled to 50 m resolution. The wind atlas will furthermore include information on extreme winds and uncertainties. Several large field experiments have been conducted in the framework of the NEWA project to be used for model validation.

References

- [1] www.neweuropeanwindatlas.eu,
- [2] Petersen, E. L., Troen, I., Jørgensen, H. E., Mann, J.: Are local wind power resources well estimated? *Environ. Res. Lett.*, 8, 011005, doi: 10.1088/1748-9326/8/1/011005 (2013)
- [3] Troen, I., Petersen, E. L.: *European Wind Atlas*, Roskilde: Risoe National Laboratory (1989)
- [4] Petersen, E. L., Troen, I.: Wind conditions and resource assessment, WIREs Energy *Environ.*, 1, 206–17, doi: 10.1002/wene.4 (2012)
- [5] Mann, J.; Angelou, N.; Arnqvist, J.; Callies, D.; Cantero, E.; Chávez Arroyo, R.; Courtney, M.; Cuxart, J.; Dellwik, E.; Gottschall, J.; Ivanell, S.; Kühn, P.; Lea, G.; Matos, J. C.; Palma, J. M. L. M.; Pauscher, L.; Peña, A.; Sanz Rodrigo, J.; Söderberg, S.; Vasiljevic, N.; Veiga Rodrigues, C.: Complex terrain experiments in the New European Wind Atlas, *Phil. Trans. R. Soc. A*, 375, 20160101, doi: 10.1098/rsta.2016.0101 (2017)
- [6] DTU Wind Energy: The Perdigao 2017 Field Experiment, Video on YouTube, <https://youtu.be/rd3MUG715Bs> (2017)
- [7] Vanvyve, E.; Delle Monache, L.; Monaghan, A. J.; Pinto, J. O.: Wind resource estimates with an analog ensemble approach, *Renew. Energ.*, 74, 761–773, doi:10.1016/j.renene.2014.08.060 (2015)

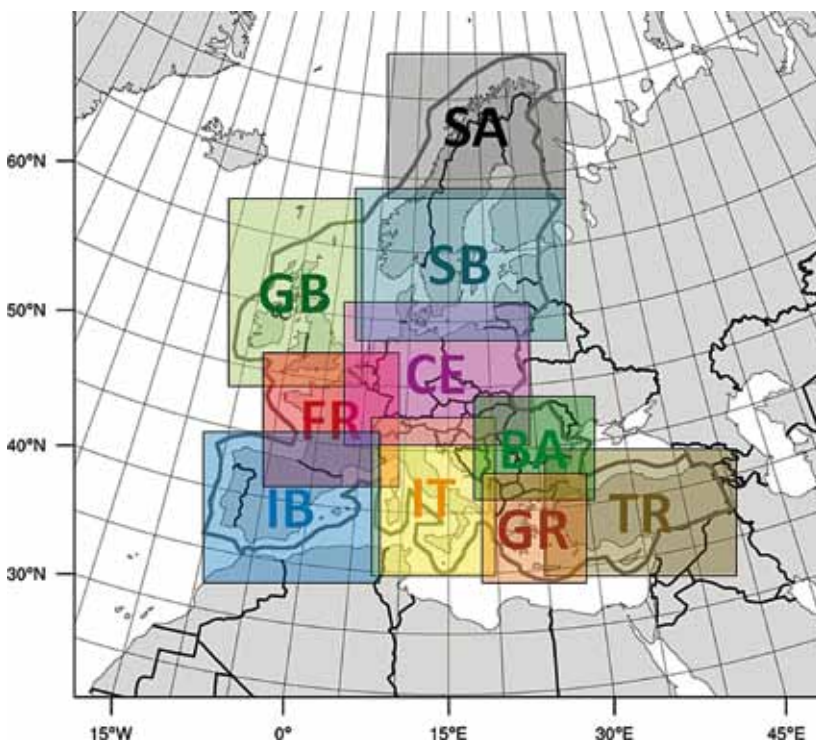

Figure 3: Domain configuration for the mesoscale wind atlas production runs. The thick grey line delimits the area of the final wind atlas

High Performance Computing (HPC) Cluster (WIMS-Cluster)

Carl von Ossietzky Universität Oldenburg
Institute of Physics

Joachim Peinke, Vlaho Petrovic,
Gerald Steinfeld, Wilke Trei, Lena Vorspel,
Sonja Krüger, Mehdi Vali, Marc Bromm,
Hauke Wurps, Stefan Harfst,
Stefan Albensöder, Shumian Zhao

Funding: Federal Ministry for Economic
Affairs and Energy (BMWi)

Ref.Nr. FKZ 0324005

Duration: 11/2015 – 10/2019

Introduction

The main topics of wind energy research are the improvement of turbine designs and investigations about the interaction of the turbines with the atmospheric boundary layer. Computational fluid dynamics (CFD) is a crucial tool for used for the investigation of this interaction in a time and resource efficient manner.

To allow for CFD simulations providing the necessary detailed resolution to address current research questions in the fields of wind turbine design and wind resource estimation on meso- and micro-scales, considerable computational resources are required.

Funded by the German Federal Ministry for Economic Affairs and Energy (BMWi), the High Performance Computing (HPC) cluster EDDY (Heterogener Hochleistungsrechner für windenergierelevante Meteorologie- und Strömungsberechnungen (WIMS-Cluster)) has been acquired and operated by ForWind (University of Oldenburg).

Using the powerful HPC cluster, this project addresses three principal scientific questions: It aims at an improved understanding of the interaction of the atmospheric boundary layer flow with wind turbines as well as the impact on the wind turbine performance, such as power generation and loads. Moreover, the project tackles the improvement of computational methods to allow for a holistic simulation of wind turbines

Project Description

HPC Cluster operation

The first phase of the project was dedicated to the acquisition and installation of the High Performance Computing cluster EDDY, which is equipped with 5.856 CPU cores that are apportioned to 244 computing nodes. All nodes share 21 TB of main memory and are connected via a non-blocking FDR infiniband interconnect for massive parallel computations. The cluster shares much of its infrastructure with the general-purpose scientific computing HPC cluster CARL of the Carl von Ossietzky Oldenburg.

Starting in August of 2016, the housing of the two HPC clusters and the technical installation was completed by the end of October 2016.

The installation phase ended with an ensuing official LINPACK [1] benchmark test, in which the two systems with a combined 571 computing nodes reached 457.2 Tflop/s (tera floating point operations per second). They were thus ranked 363th on the Top 500 worldwide scientific supercomputers list in November 2016 [2].

From November 2016 until February 2017 the installation of the scientific software and an in-depth testing phase took place. Subsequently, the HPC cluster was made available for scientific computations in March 2017.

Since the start of its regular operation, the HPC cluster has been subject to multiple planned updates and optimizations of the installed software in order to guarantee optimal scientific results. User support for about 55-60 users has been provided continuously during the project, including the support for migrating projects on larger scale HPC systems and investigations in the rare case of problems. Therefor the close coordination between the IT-department and the ForWind cluster operator was essential.

Interaction of Wind Turbines with the Atmospheric Boundary Layer

The first scientific work package in this project addresses the interaction between the atmospheric boundary layer (ABL) flow and the wind turbines. Particular emphasis is given to the stable stratified atmospheric boundary layer, which occurs in the southern North Sea region about 20% of the time and in the northern German onshore region about 40% of the time [3]. The stable stratification causes significant wind speed variations across the wind turbine rotor and results in asymmetric and long-lasting wake flows, which are currently not represented in engineering models.

An optimized coupling of the large eddy simulation (LES) model PALM [5] with the aeroelastic model FAST [4] has been realized to create a suitable simulation tool chain for the investigation of interactions of a wind turbine with a stable stratified atmospheric boundary layer. The coupled method has been assessed and optimized regarding computational costs and stability. The resulting improved LES model will be used to investigate wind farm control schemes and to improve the mesoscale model WRF [6].

Wind Farm Control by a Coupled Aeroelastic Model with Large Eddy Simulations

Different atmospheric conditions have a large impact on the properties of wind tur-

bine wakes such as the wake recovery and the wake expansion. However, the wake flow is also impacted by the wind farm control itself, for example in yawed inflow cases or by means of so-called wake steering.

The developed coupled LES model is used to simulate the wake of a wind turbine exposed to various different inflow situations – including different atmospheric stabilities as well as different operational conditions and control strategies of the wind turbine. Wind fields of the wind turbine wake are extracted from the LES to estimate the power performance and loads of downstream turbines using the aeroelastic tool FAST. During the project, the results will be validated against measurements from a field campaign in order to assess the feasibility of the load estimation method.

High Performance Code for Holistic Simulations of Wind Turbines

CFD simulations have proven to be effective in the development process of aerodynamically critical components. A desired future development in wind turbine design is a holistic automatic optimization process. This cannot simply be achieved by using modern high performance computing facilities, but also requires an improved efficiency of the used CFD algorithms. New numerical strategies are thus investigated and their efficiency and scalability is assessed.

A coupled algorithm, which solves the equations for the pressure and the velocity components simultaneously, has been implemented in the CFD code OpenFoam [7]. The solver makes use of the so-called LU-SGS algorithm in order to achieve significantly reduced computational times compared to conventional solvers. Current work focuses on stability and performance

improvements as well as improved grid projection methods. Additional tasks include the adaption of such algorithms for implementation on graphic cards, which is projected to improve the overall performance per hardware cost ratio significantly.

Summary

The successful installation and operation of the High Performance Computing cluster EDDY provides an important tool for multiple research projects. Within the first half of the project WIMS-Cluster, capabilities of several simulation methods have been advanced, including the improvement of algorithms as well as the coupling of different methods. This allows for the investigation of important research questions, such as the impact of the atmospheric boundary layer and wind turbine control schemes on wind farm wakes.

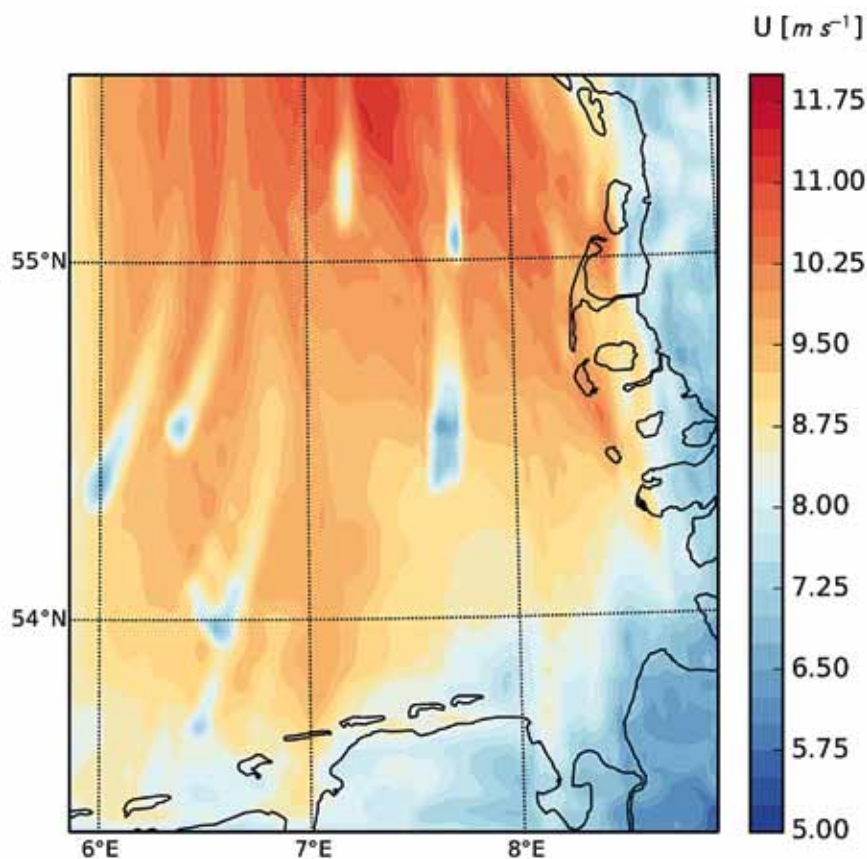

Figure 1: Offshore Wind Farm Wakes in the German bight

References

- [1] <http://www.netlib.org/linpack>
- [2] <https://www.top500.org/site/50678>
- [3] Dörenkämper, M., Witha, B., Steinfeld, G., Heinemann, D., Kühn, M., 2015: The impact of stable atmospheric boundary layers on wind-turbine wakes within offshore wind farms. *J. Wind. Eng. Ind. Aerod.*, doi: 10.1016/j.jweia.2014.12.011.
- [4] <https://www.nas.nasa.gov/Software/FAST/>
- [5] <https://palm.muk.uni-hannover.de>
- [6] <https://www.mmm.ucar.edu/weather-research-and-forecasting-model>
- [7] <https://openfoam.org/>

Further Development of a Two-dimensional Atmospheric Laser Cantilever Anemometer for the High-resolution Investigation of Turbulent Wind Flows for the Optimization of Offshore Wind Turbine Blades

Carl von Ossietzky Universität Oldenburg
Institute of Physics
Research Group: Turbulence, Wind Energy
and Stochastic

Jaroslav Puczyłowski, Joachim Peinke,
Michael Hölling

Funding: Deutsche Bundesstiftung Um-
welt (DBU)

Ref.Nr. 32399/01

Duration: 12/2015 – 12/2016

Introduction

Since intermittent wind fields cause high loads on wind turbines, which can lead to damage, a very precise knowledge of the structure of the wind field is necessary to combat this danger, i.e. to know which vortex sizes can occur. The investigation of the smallest vortex structures in the range of a few millimeters is also necessary. Even if these do not make a significant contribution to the loads, they are decisive for the aerodynamics of the rotors and thus for the yield of the wind turbine. Furthermore, high-resolution data serve as a basis for the development of turbulence models, which in turn are essential for CFD calculations [1,2]. These simulations are often used in research and industry as a cost-effective alternative to complex measurements and are becoming increasingly popular due to the constantly increasing computing power of computers.

Even though the demand for high-resolution wind speed data from industry and the research community is very high, there are currently no such measurements in the offshore area and only very few measurements in the onshore area [3,4,5,6]. This is due to the lack of suitable measuring instruments. For measurements in wind tunnels, hot wires are a widespread standard for high-resolution measurements, but due to their nature (1-5 μ m thick) they are not suitable for long-term measurements in offshore applications.

Within the framework of a joint project between the Kiel University of Applied Sciences and the University of Oldenburg, a new sensor has been developed to address this challenge. The so-called 2D-ALCA enables spatial and temporal high-resolution measurements in the offshore area. The measuring principle utilizes a laser-based measurement of the deflection of a very small bending beam, which is deflected by the flow. In comparison to hot wires, this sensor element is very robust against external influences and is therefore basically suitable for use in offshore applications.

Project Description

The aim of this project is the further development of the existing 2D-ALCA measurement system in order to avoid the problems encountered in an earlier project [7], so that at the end of this project a functional prototype is available, which is suitable for a possible product development within the scope of a cooperation with Sea & Sun GmbH.

In order to achieve a better temporal resolution (>10 kHz), a weight-reduced cantilever is to be developed so that its resonance fre-

quency is outside the measuring range. In addition, a tracking system is to be developed so that the offshore measurements can be carried out more independently of the wind direction and a sudden change in the wind direction does not result in the measurement being aborted or even dropped out. In addition, the reliability of the measured values is to be further increased by temperature control, which makes the sensor more independent of temperature fluctuations and thus lessens the impact of environmental influences. In order to extend the service life of the measuring system as a whole, an additional cover is to be constructed from which the sensor is only moved out for the measurements. These measures are all aimed at making the 2D-ALCA more robust and resistant to offshore conditions in the North Sea. In order to assess the effectiveness of these improvements in a meaningful way, free-field measurements are to be carried out on the FINO3 in the North Sea and the system is to be extensively tested.

After successful tests of the renewals and improvements on the 2D-LCA, the measuring system was tested on the Fino3 platform under real conditions. Fig. 1 shows the installed measurement system on the metmast at a height of 90m.

Measurements were carried out and analyzed on different days. The graph in fig. 2 shows an example of a time series for the absolute velocity and flow direction for the 2D-ALCA and an ultrasonic anemometer, which was installed in the immediate vicinity.

Summary

The aim of this project was the further development of 2D-ALCA to validate a robust and for the offshore area suitable measurement method, which allows temporally and spatially high-resolution measurements of the atmospheric boundary layer. With the development of a cover, the service life of the sensor could be significantly extended, and improved angular coverage and more

stable signal quality could be achieved through tracking and temperature control. Thus a considerable improvement of the system could be achieved and tested under offshore conditions.

Despite minor problems, the measurements have shown that the atmospheric boundary layer can be measured with 2D-ALCA under offshore conditions with high temporal resolution. Triggered measurements

enabled the measurement method to be validated directly by an anemometer. In addition, the service life of the system could be significantly extended, even if a detailed statement about the service life could not be given due to external problems in the data connection. Besides the application in offshore turbulence measurement, further application possibilities in other research areas are conceivable.



Figure 1: The 2D-ALCA mounted at the metmast of the FINO3-platform.

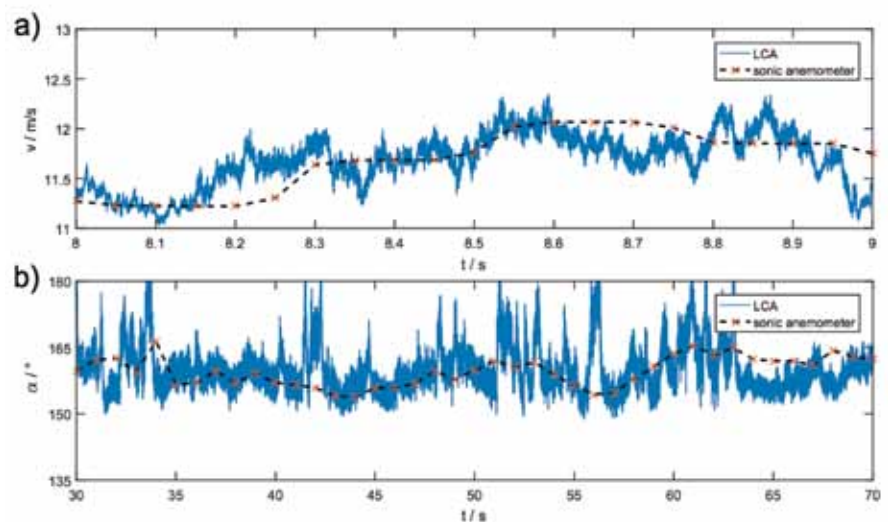

Figure 2: Time series of the 2D-ALCA measurement in comparison with the ultrasonic anemometer (section of measurement). a) Wind speed, b) Wind direction.

References

- [1] Barthelmie, R. J.; Hansen, K.; Frandsen, S. T.; Rathmann, O.; Schepers, J. G.; Schlez, W.; Phillips, J.; Rados, K.; Zervos, A.; Politis, E. S.; Chaviaropoulos, P. K.: Modelling and measuring flow and wind turbine wakes in large wind farms offshore. In: *Wind Energy* 12 (2009), Nr. 5, pp. 431–444. – ISSN 1099–1824
- [2] Mücke, Tanja; Harkness, Christine; Argyriadis, Kimon: Offshore Wind Turbulence - Model versus Measurement. In: *EWEA Offshore 2012*, Copenhagen, Denmark, 2012
- [3] Schreck, S.; Lundquist, J.; Shaw, W.: U.S. Department of Energy Workshop Report: Research Needs for Wind Resource Characterization, National Renewable Energy Laboratory / NREL/TP-500-43521 (2008) – Forschungsbericht
- [4] Neumann, T.; Emeis, S.; Grigutsch, K.; Riedel, V.; Türk, M.: OWID Offshore Wind Design Parameter. In: *DEWI Magazin* Nr. 35 (2009)
- [5] Sreenivasan, K. R.; Dhruva, B.: Is there Scaling in High-Reynolds-Number Turbulence? In: *Progress of Theoretical Physics Supplement* No 130 (1998)
- [6] Siebert, Holger; Lehmann, Katrin; Shaw, Raymond A.: On the use of a hot wire anemometer for turbulence measurements in two-phase flows – A wind tunnel study. In: *Journal of Atmos. Ocean. Technol.* (2007)
- [7] Jeromin, Andreas; Schaffarczyk, Alois P.: Messung und Analyse hochfrequenter ($\gg 1$ kHz) Turbulenzanteile im Offshore-Wind zur Optimierung von aerodynamischen Blattprofilen / Abschlussbericht zu Projekt 122-09-023, gefördert vom Land Schleswig-Holstein (2012) – Forschungsbericht

Extended THETA for Site Assessment (ETESIAN)

Carl von Ossietzky Universität Oldenburg
Wind Energy Meteorology

Renko Buhr, Siamak Akbarzadeh,
Johannes Munk, Björn Witha,
Gerald Steinfeld

Partners: Fraunhofer IWES, DLR-AS-CAS,
WRD (lead)

Funding: Federal Ministry for Economic
Affairs and Energy (BMWi)

Ref.Nr. 0324000D

Duration: 01/2016 – 12/2018

Introduction

Besides re-powering of wind turbines at reliable high-yield locations, the placement of wind turbines in less promising onshore locations (complex and forested terrain) is of significant importance in the conversion of the German energy system to renewable energies. This makes the site assessment much more difficult, so new and more efficient numerical methods for site assessment are required.

The main focus of the joint project ETESIAN is to transfer high resolution numerical approaches from academic research to the industrial site assessment process. Our project partner DLR provides their well-established CFD solver THETA which has previously been used for industrial CFD applications. Together with Fraunhofer IWES ForWind will significantly enhance this code so that it can be applied to atmospheric flows. Project partner and consortium leader WRD will then integrate the enhanced solver into Enercon's industrial site assessment process chain.

Project Description

A main objective of ForWind's work in ETESIAN is to modify the CFD solver THETA in such a way that it can simulate the atmospheric boundary layer and can be used in Enercon's industrial site assessment. The enhancement of the code includes the implementation of a thermal solver that can handle non-neutral situations, the representation of complex terrain in terms of roughness, forest and orography as well as wake modelling. A further focus of the project is to automatize the calibration to important site assessment parameters like roughness and stability which is currently done in a manual process.

Terrain roughness and forest

A CFD solver to be used in site assessment needs to consider terrain roughness and specifically forests. Regarding terrain rough-

ness, the effect of physical obstacles on the surface like grass, buildings or trees have to be represented. In general a surface roughness is used similarly to engineering models. Forests are of special interest in wind energy, as more and more wind parks are built in forested regions. Therefore the simple representation with a surface roughness is not sufficient. The Darcy-Forchheimer-Model [1] was implemented into the THETA code to account for sinks and sources of the forest in both turbulence and momentum. Two different types of forests have been compared and the results were presented at the Wind Energy Science Conference 2017 [2]. Fig. 1 shows the effect of the forest on the flow. Within the forest, the flow is slowed down, above (and at the sides of the forest), a speedup effect is visible. Behind the forest the flow is forced back to the inflow profiles. Several kilometers are necessary to reach free flow conditions.

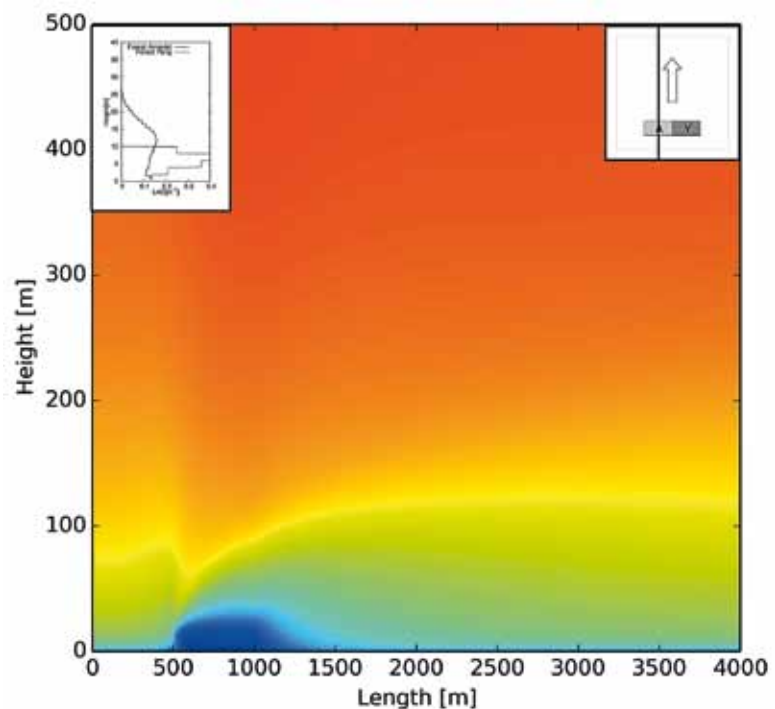

Figure 1: Flow over a forest (streamwise wind component)

Thermal Solver

While in wind energy applications the atmosphere is often assumed to be neutrally stratified, this stratification is barely present in the planetary boundary layer. Therefore, additional source terms have been added to the model, following the Monin-Obukhov Similarity Theory. In detail the model proposed by project partner Fraunhofer IWES [3] was implemented in close collaboration with the project partners Fraunhofer IWES and DLR. A stable stratification dampens vertical movement and therefore turbulent exchange, leading to a stronger vertical wind shear, while a convective stratification enhances turbulent exchange with smaller vertical wind shear. The effect on vertical exchange can be seen particularly in Figure 2, in the wake effect behind a standardized cosine hill.

Coriolis force

The planetary boundary layer can be divided in two important parts, the Prandtl- and the Ekman-Layer. While the first is only influenced by the surface friction and no horizontal wind shears can be observed, the Ekman-Layer is additionally influenced by the free atmosphere and therefore by the Coriolis force. This leads to a rotation of the wind with height. While often neglected in engineering models an advanced numerical model for site assessment should include the Coriolis force. The implementation of the Coriolis force in THETA has been fairly straightforward. Additionally, the turbulent length scale of the flow had to be limited in order to get reasonable results. The results were in good agreement with the well-known Leipzig dataset.

Automatized model calibration

Typically measurements over a certain period are available for prospective wind farm sites. Depending on the size of the wind farm these measurements have been performed at one or several locations within the wind farm. CFD simulations, however, depend on inflow conditions at the boundaries of the simulated domain which are not known a-priori. The accuracy of the simulations is massively depending on the boundary conditions which have to be calibrated with the met mast data.

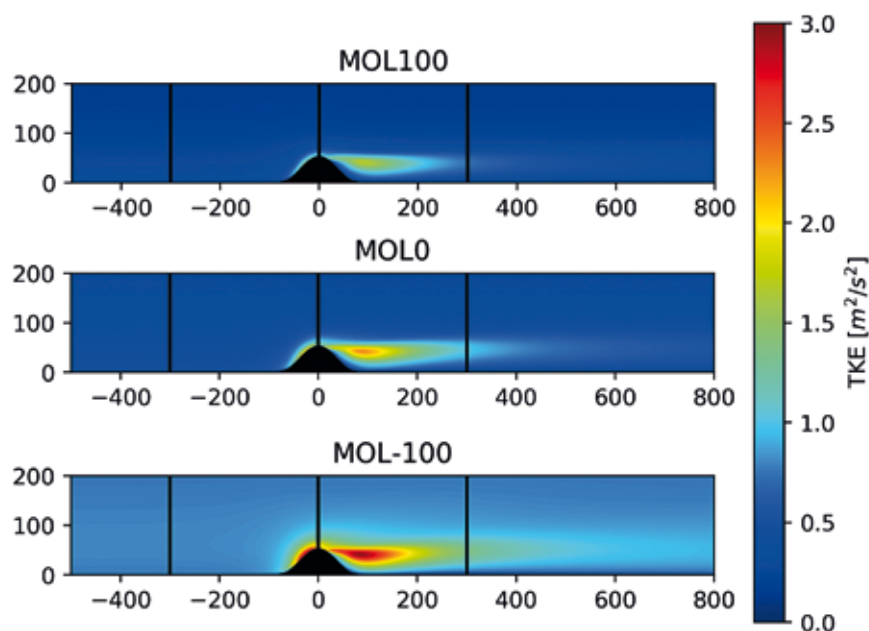

Figure 2: Flow over a cosine hill: Turbulent kinetic energy (TKE) for stable (top), neutral (middle) and convective (bottom) atmospheric stratification

A central part of the project work is to explore the systematic and automatized calibration of two important parameters of the thermal solver which is implemented in the THETA code: the aerodynamic roughness length z_0 and the atmospheric stability through the Obukhov length L .

Summary

In ETESIAN the CFD solver THETA will be significantly enhanced and modified so that it can simulate the atmospheric boundary layer and can be used in industrial site assessment. The enhancement of the code includes the implementation of a thermal solver that can handle non-neutral situations, the representation of complex terrain in terms of roughness, forest and orography as well as wake modelling. A further focus of the project is to automatize the calibration to important site assessment parameters like roughness and stability which is currently done in a manual process.

References

- [1] Bejan, A.: Convection in porous media in A. Bejan (Ed.), Convection Heat Transfer, 4th edition (pp 540-542), Jon Wiley & sons, Inc., Hoboken, New Jersey, doi: 10.1002/9781118671627, 2013
- [2] Buhr, R.; Aposporidis, A.; Munk, J.; Steinfeld, G.; Heinemann, D.: RANS simulations of flows above forest canopies of different topologies, Wind Energy Science Conference 2017, Technical University of Denmark, Lyngby Campus, June 26 - 29 June 2017.
- [3] Chang, C-Y; Schmidt, J; Dörenkämper, M; Stoevesandt, B: A consistent steady state CFD simulation method for stratified atmospheric boundary layer flows, J. Wind Eng. Ind. Aerodyn., 172, 55-67, 2018

Highly Accelerated Pitch Bearing Test

Leibniz Universität Hannover
Institute for Machine Design and
Tribology (IMKT)

Fraunhofer-Institute for Wind Energy
Systems (IWES)

Matthias Stammeler, Arne Bartschat,
Florian Schleich, Karsten Behnke,
Oliver Menck, Fabian Schwack

Funding: Federal Ministry for Economic
Affairs and Energy (BMWi)

Ref.Nr. 0325918A

Duration: 01/2016 – 09/2020

Introduction

Pitch bearings of wind turbines are large, grease-lubricated rolling bearings that connect the rotor blades with the rotor hub. They are used to turn (pitch) the blades around their primary axis. Turning the blades changes the amount of lift they generate. Thus, pitching can be used for both power and load control of the wind turbine. The largest rotatory movement of a blade is a 90° turn, which is used to change from power production mode to idling or vice versa. Under most circumstances, all movements of pitch bearings are oscillatory, as the power output of the blades is at maximum at the 0° position. As the wind speed and turbulence are of complex, stochastic nature, this is also the case for the loads and movements of blade bearings [1].

The complex load situation in combination with the oscillating movements and the ever-increasing size of the bearings have made bearing tests more and more important. HAPT pursues two main goals: Further develop the design methods of pitch bearings and provide a test infrastructure for bearings of turbines of up to 10 MW, together with a comprehensible method for acceptance tests. IWES joined with the IMKT and the bearing manufacturer IMO to achieve these goals.

Project Description

The project splits up into two major parts: Development of calculation and simulation methods, carried out by IMKT, and development of test rig and test method, carried out by IWES.

IMKT uses a combined approach of test with type 7208 roller bearings and finite element simulation to understand the fundamentals of wear damage modes under oscillatory conditions [2, 3].

IWES undertakes efforts to understand the external loads and bearing movements [1, 4] and transform the conditions of the wind turbine application to a test environment. The name of test environment is BEAT6.1 (Bearing Endurance and Acceptance Test rig). IWES commissions the test rig in January 2019. Within the project, IWES will test six blade bearings with a diameter of 5 m.

Summary

HAPT deals with pitch bearings of wind turbines and aims at improving their reliability. The collaboration between Fraunhofer IWES, LUH IMKT and the bearing manufacturer IMO has led to significant progress in the field of simulation and test. The project will culminate in the endurance test of six pitch bearings with the size of 5 m at the newly built BEAT6.1 test rig.

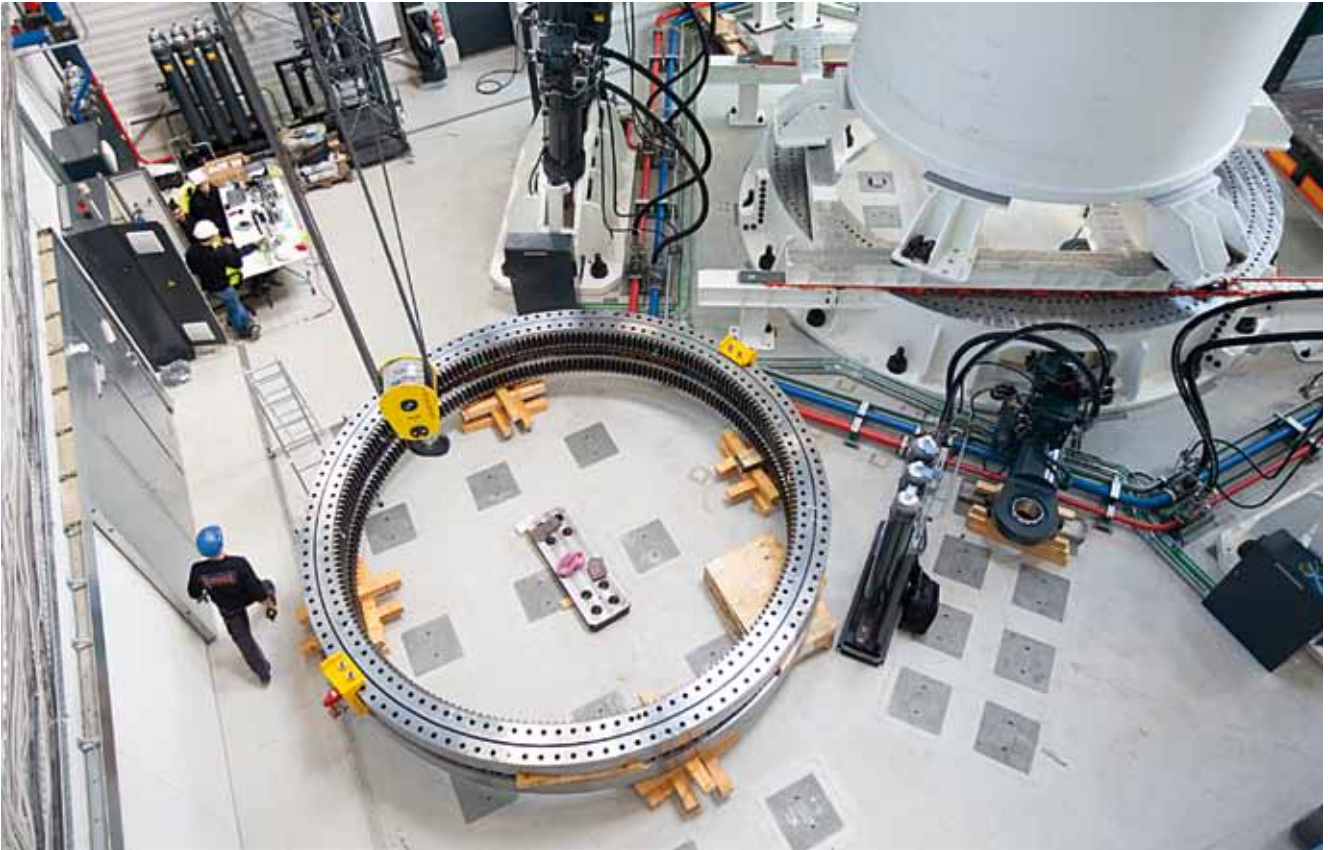

Figure 1: 5 m bearings next to the BEAT6.1 test rig

References

- [1] Stammer, M.; Reuter, A.; Poll, G.: Cycle counting of roller bearing oscillations – case study of wind turbine individual pitching system *Renewable Energy Focus* 25, pp. 40–47 (2018)
- [2] Schwack, F.; Byckov, A.; Bader, N.; Poll, G.: Time-dependent analyses of wear in oscillating bearing applications, Atlanta (2017)
- [3] Schwack, F.; Prigge, F.; Poll, G.: Frictional Work in Oscillating Bearings – Simulation of an Angular Contact Ball Bearing under Dry Conditions and Small Amplitudes, Beijing, China (2017)
- [4] Stammer, M.; Baust, S.; Reuter, A.; Poll, G.: Load distribution in a roller-type rotor blade bearing. *J. Phys.: Conf. Ser.*, p. 1037 (2018)

Lidar for Wind Energy Deployment (IEA Annex 32) – Phase II

Carl von Ossietzky Universität Oldenburg,
Institute of Physics
Research Group: Wind Energy Systems

Davide Trabucchi

Funding: International Energy Agency
IEA – Task 32 – Phase II

Ref.Nr. IEA - Task 32: Wind Lidar Systems
for Wind Energy Deployment – Phase II

Duration: 01/2016 - 12/2018

Introduction

IEA Task 32: is a task included in the International Energy Agency Wind Technology Collaboration Programme (IEA Wind TCP), a cooperation that shares information and research activities to advance wind energy research, development and deployment with its member countries, under the support of the International Energy Agency (IEA).

Project Description

The Phase II of the IEA Task 32: Wind Lidar Systems for Wind Energy Deployment started in 2016 and is focused on identifying and mitigation barriers to the deployment of wind lidar in four application areas:

1. Site assessment.
2. Power performance testing.
3. Turbine controls and load verification.
4. Complex flow.
5. Out of the box: Introduced in 2017, it addresses new developments such as the use of lidar forecasting of wind speed and power, the "Open Lidar" modular lidar concept.

The advisory board of the task is composed mainly of academics and industry representatives. The advisory board organizes monthly conference calls and annual meetings to bring the entire Task 32 community together. Over 250 participants contributed to the meetings and workshops organized in Phase II.

Along with the annual meetings, different workshops are being conducted to solve the challenges set by the community. During 2016-2017 the following workshops were organised:

- Workshop #1: Floating Lidar System: Current Technology Status and Requirements for Improved Maturity. ORE Catapult, Blyth, UK. February, 23-24, 2016
- Workshop #2: Optimizing Lidar Design for Wind Turbine Control Applications. Boston Marriott Copley Place, Boston, MA, USA. July, 5, 2016.
- Workshop #3: Lidar measurements for wake assessment and comparison with wake models. Technical University of Munich, Munich, Germany. October, 4, 2016
- Workshop #4: Power Performance: Round Robin for FDIS IEC 61400 12-1 Ed. 2. Calculation of Uncertainty for Lidar Application. University of Strathclyde, Glasgow, Scotland Scotland. Round Robin August-December 2016. Final workshop: December, 14, 2016.
- Workshop #5: Elaboration of use cases in wake and complex flow measurements. University of Glasgow, Glasgow, Scotland. June, 19-20, 2017
- Workshop #6: Power Performance Measurement Using Nacelle Lidars. DONG Energy, Gentofte, Denmark, September, 27, 2017
- Workshop #7: Lidar Campaigns in Complex Terrain. University of Stuttgart, Stuttgart, Germany. November, 8, 2017

Summary

IEA Task 32 Phase II is a task included in the IEA Wind TCP. It aims at identifying and mitigating barriers to the use of lidars for different wind energy applications including site assessment, power performance testing, turbine controls and load verifications and complex flow. Workshops are organized regularly to address the challenges set by the scientific committee. Results of the workshop are published in different journals, workshop reports and recommended practices.

References

- [1] Bischoff, O.; Würth, I.; Gottschall, J.; Gribben, B.; Hughes, J.; Stein, D.; Verhoef, H.: IEA Wind RP 18. Floating Lidar Systems
- [2] Sathe, A.; Banta, R.; Pauscher, L.; Vogstad, K.; Schlipf, D.; Wylie, S.: Estimating Turbulence Statistics and Parameters from Ground- and Nacelle-Based Lidar Measurements.
- [3] Clifton, A.; Boquet, M.; Burin, E.; Hofsäb, M.; Klaas, T.; Vogstad, K.; Clive, P.; Harris, M.; Wylie, S.; Osler, E.; Banta, R.; Choukulkar, A.; Lundquist, J.; Aitken, M.: Remote Sensing of Complex Flows by Doppler Wind Lidar: Issues and Preliminary Recommendations.

GROWup OPC– Grouted Joints for Offshore Wind Energy Converters under Reversed Axial Loadings and Upscaled Thicknesses filled with Ordinary Portland Cement (OPC)

Leibniz Universität Hannover
Institute for Steel Construction
(project leader)
Institute of Building Materials Science
(project co-leader)

Peter Schaumann, Anne Bechtel,
Alexander Raba, Joshua Henneberg (IfS)
Ludger Lohaus, Michael Werner,
Dario Cotardo (IfB)

Funding: Federal Ministry for Economic
Affairs and Energy (BMWi)

Ref.Nr. 0325290

Duration: 06/2011 – 07/2017

Introduction

Connections between the foundation piles and the support structures of offshore wind turbines are executed by filling the annulus between the two steel tubes with a cementitious grout material. In general, specialized high-performance mortar grouts are used in Germany with respect to the certification body and BSH. Usually, high-performance mortar grouts are cost-intensive and are more sensitive to fluctuations in the water content as well as to varying temperatures, both aspects influence the flowability. To this end, the application of an ordinary Portland cement grout (OPC-grout), which represents a standardized building material, could provide an economic and executional benefit. Indeed, OPC-grouts are already used worldwide and established not only in the oil and gas industry. However, the application of OPC-grouts for offshore wind turbines in Germany is not usual and is only accepted in individual cases with respect to the approval procedure.

Project Description

The development of offshore wind turbines in Germany and worldwide is becoming more efficient and cost effective. The substitution of a high-performance mortar grout typically used with a standardized OPC-grout could have significant economic advantages. The aim of the investigations presented was to compare typical cement grouts with an established high-performance mortar grout and, furthermore, to proof the usability of different OPC-grouts as a grout material in grouted joints for offshore wind turbines. A large-scale test facility for the simulation of filling processes for the in situ assembly of grouted joints was developed. In addition, a submerged test facility was developed, cf. Fig. 1, and was used for investigations to quantify the hydration heat development under nearly realistic conditions.

As a result of the experimental investigations it has been shown that OPC grouts are generally suitable for grouted joints of offshore wind turbines. Using a slurry mixer sufficient properties regarding the pumpability and the flowability can be achieved. In order to achieve a sufficiently high early and final strength of the grout, especially Portland cements with a strength class of 52.5 are suitable, cf. Fig. 2 [1]. Using OPC grouts, an increased hydration heat development must be expected. In order to avoid temperature-induced expansion phenomena, the use of cements with increased sulphate resistance is recommended.

In addition material tests, analyses of filling processes and the fatigue behaviour of different grout materials were determined using small- and large-scale test facilities for cyclic axial loading. With special focus on submerged conditions and the occurring failure mechanism.

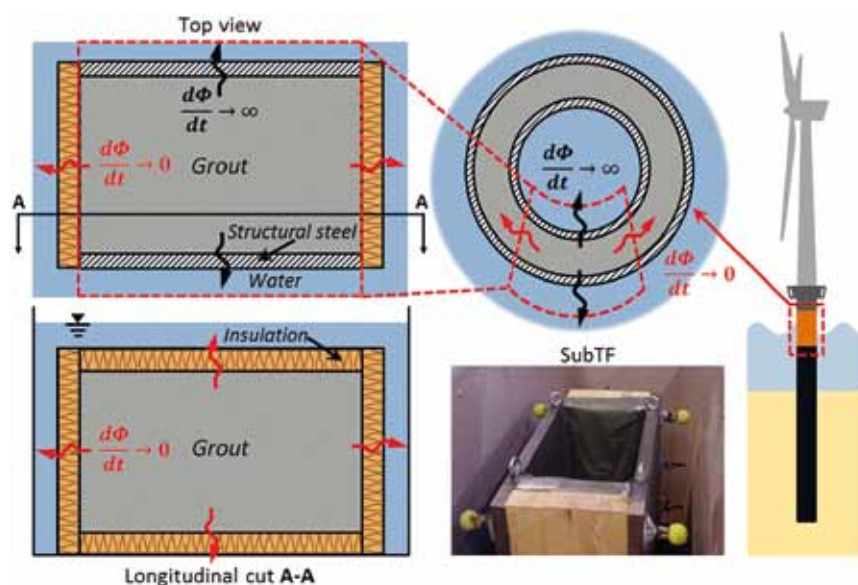

Figure 1: Test facility for hydration heat development under submerged ambient conditions

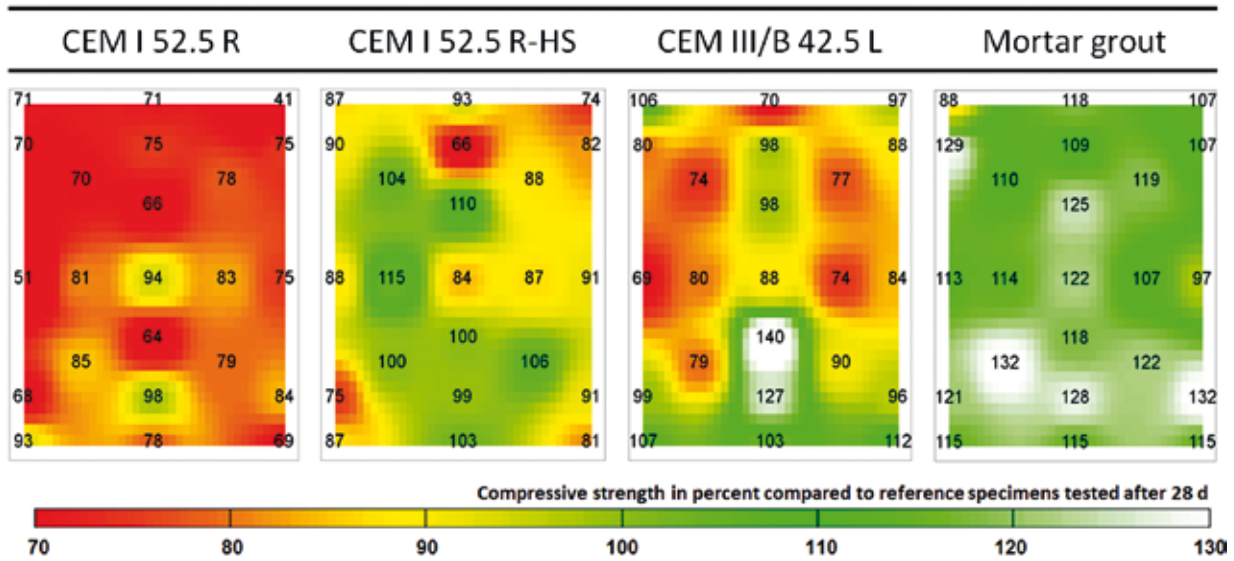
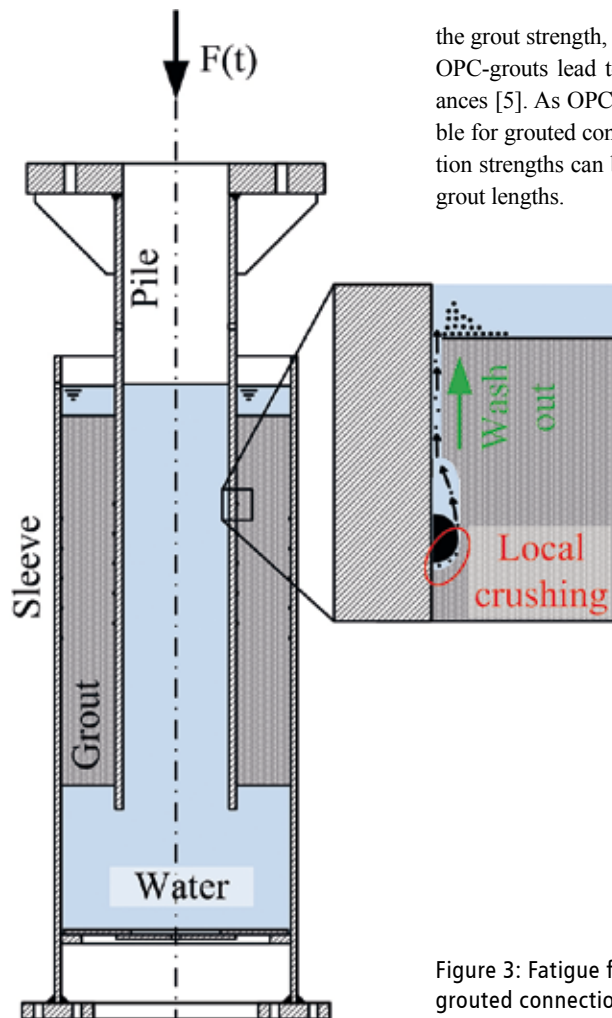

Figure 2: Relative compression strength distribution of filling test setup

Due to shear keys on the inner surfaces of the grouted connection the interlocking between steel and grout increases. This leads to different failure mechanisms under dry and submerged ambient conditions. In both cases grout material nearby the shear keys crushes as consequence of locally concentrated load transfer. Crushed material leads to notch smoothing effects around the shear key and stops further damage under dry ambient conditions. Further connection resistances can be activated. A grouted connection in dry ambient conditions finally fails after additional load increase due to shear cracking (so called compression strut failure) [2]. Contrarily, submerged ambient conditions lead to water ingress into the connection [3]. Due to pumping effects, caused by cyclic loading and elastic deformations, the crushed grout material is washed out, cf. Fig. 3. Over time, the grouted connection fails by pushing the pile continuously through the grout material [4]. Under more realistic submerged ambient conditions the fatigue resistance of axially loaded grouted connections decreases significantly.

Small-scale tests under varying load frequencies show lower fatigue resistances with higher load frequencies cf. Fig. 4. Due to local grout failure the resistance of grouted connections directly depends on



the grout strength, which is one reason why OPC-grouts lead to reduced fatigue resistances [5]. As OPC-grout is generally suitable for grouted connections, higher connection strengths can be reached by increasing grout lengths.

Figure 3: Fatigue failure mechanism of grouted connection under submerged ambient conditions

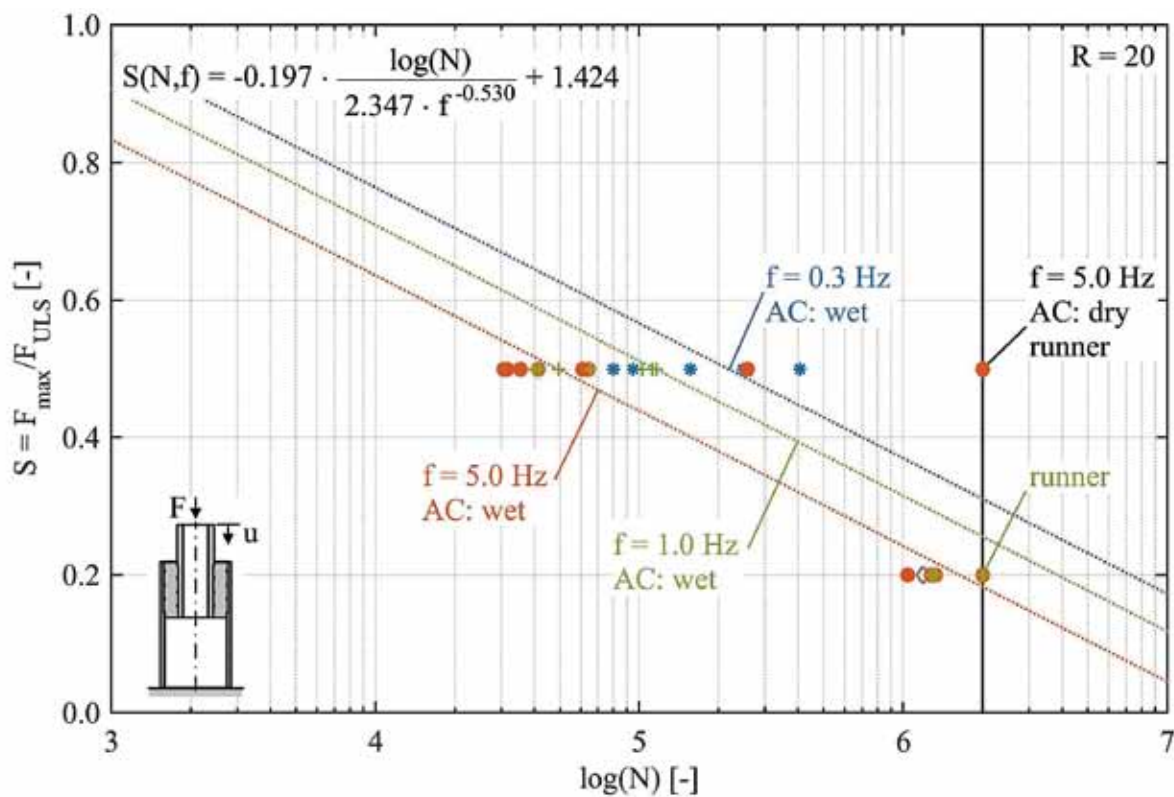

Figure 4: SN-curve showing influence of load frequency on fatigue resistance

Summary

All in all, numerous experimental and numerical investigations are carried out within the BMWi-research project GROWup OPC, which led to two main results. Firstly, OPC-grout is generally suitable for offshore use in grouted connections. Due to lower strength of the material itself more grout length is necessary to reach comparable resistances to grouted connections with high strength grout. Secondly, submerged ambient conditions lead to a different failure mechanism under cyclic loading and thereby to a significant decrease of fatigue resistance of the grouted connection.

The financial support by the Federal Ministry for Economic Affairs and Energy as well as the support by Fraunhofer IWES, Det Norske Veritas Germanischer Lloyd Group, Senvion SE, RWE Innogy and Strabag Offshore is kindly acknowledged.

References

- [1] Cotardo, D.; Lohaus, L.; Werner, M.: Practical Performance of OPC-grout for Offshore Wind Turbines in Large-scale Execution Tests, Proceedings of the 27th International Offshore and Polar Engineering Conference (ISOPE), San Francisco, USA, June 2017
- [2] Bechtel, A.: Fatigue Behaviour of Axially Loaded Grouted Connections in Jacket Structures. Hannover, Germany, Leibniz Universität Hannover, Institute for Steel Construction. Dissertation (2016)
- [3] Schaumann, P.; Raba, A.; Bechtel, A.: Zum Ermüdungsverhalten von Grout-Verbindungen bei unterschiedlichen Umgebungsbedingungen, in Stahlbau 85, 12/2016, pp. 679-688.
- [4] Raba, A.: Fatigue behaviour of submerged predominantly axially loaded grouted connections. Hannover, Germany, Leibniz Universität Hannover, Institute for Steel Construction. Dissertation (2018)
- [5] Schaumann, P.; Henneberg, J.; Raba, A.: Axially loaded grouted connections in offshore conditions using ordinary portland cement, 12th International Conference on Advances in Steel-Concrete Composite Structures, Valencia (2018)

INNWIND.EU – Innovative Wind Conversion Systems (10-20MW) for Offshore Applications

Leibniz Universität Hannover
Institute of Structural Analysis,
Institute for Building Materials,
Institute for Steel Construction

Jan Häfele, Andreas Ehrmann,
Niklas Scholle, Luka Radulovic

Funding: European Union's Seventh
Programme for research, technological
development and demonstration
– EC FP 7

Ref.Nr. Grant Agreement No. 308974,
INNWIND.EU

Duration: 11/2012 – 10/2017

Introduction

The research project with a total of 27 European partners is an ambitious successor for the UpWind project, where the vision of a 20MW wind turbine was put forth with specific technology advances that are required to make it happen. The overall objectives of the INNWIND.EU project are the high performance innovative design of a beyond-state-of-the-art 10-20MW offshore wind turbine and hardware demonstrators of some of the critical components.

Project Description

The overall objectives of the INNWIND.EU project are the high performance innovative design of a beyond-state-of-the-art 10-20MW offshore wind turbine and hardware demonstrators of some of the critical components. These ambitious primary objectives lead to a set of secondary objectives, which are the specific innovations, new concepts, new technologies and proof of concepts at the sub system and turbine level. The progress beyond the state of the art is envisaged as an integrated wind turbine concept with a light weight rotor having a combination of adaptive characteristics from passive built-in geometrical and structural couplings and active distributed smart sensing and control, an innovative, low-weight, direct drive generator and a standard mass-produced integrated tower

and substructure that simplifies and unifies turbine structural dynamic characteristics at different water depths.

The LUH is involved in work package 4 (offshore foundations and support structures). Here, the objective is the preliminary design of a hybrid jacket as shown in Fig. 1 that comprises classical steel and so called sandwich tubes. Sandwich tubes usually have a non-metallic core which might be an elastomer, grout or concrete, wrapped with steel faces at the inner and outer diameter. Due to the considerably better buckling behaviour of sandwich tubes compared to steel tubes it seems possible to reduce the entire costs for the substructure and hence offshore wind energy in this way. But there are many issues that have to be solved before an application of sandwich tubes for offshore structures is possible.

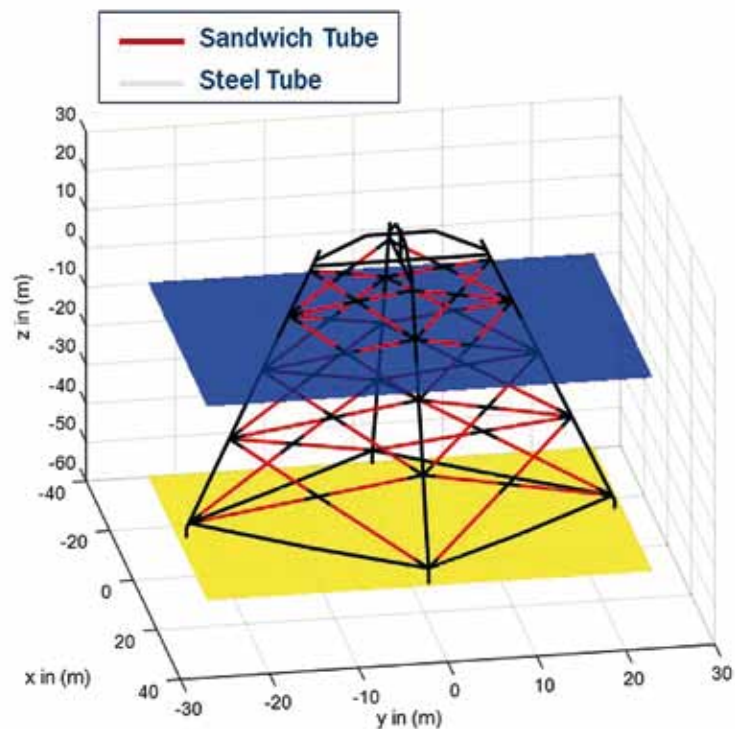
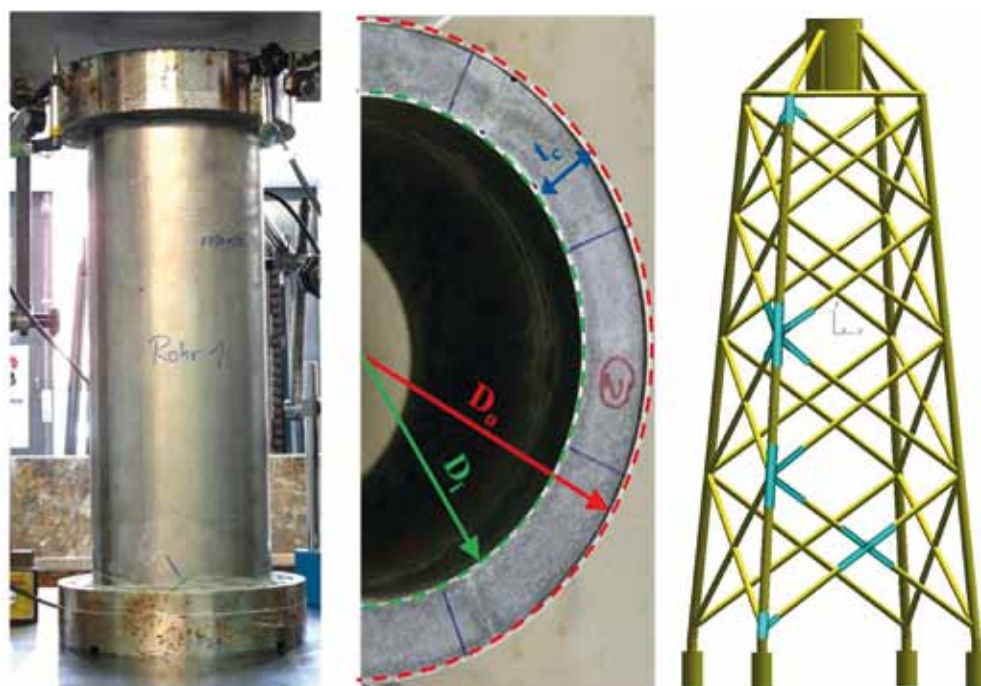

Figure 1: INNWIND.EU reference jacket design with sandwich braces

Figure 2: Bottom-fixed support structure concepts



Different jacket concepts have been developed to support the INNWIND.EU 10 MW reference wind turbine in a water depth of 50 m. Designs are based on conceptual design level using a reduced number of (governing) integrated design load calculations in order to assess the fatigue limit state and ultimate limit state. The developed solutions are compared with an initially designed reference jacket considering the structural mass and associated manufacturing costs. The reference jacket is a classical 4-leg steel jacket concept with pre-piled foundation and is developed in the beginning of the INNWIND.EU project. In parallel, automated design optimization procedures have been developed and successfully applied, connecting the design changes with the design and cost assessment in a loop. The following jacket solutions are addressed:

1. Modular 4-leg and 3-leg jackets with classical pre-piled foundation and tubular tower;
2. Full-lattice tower concept;
3. Hybrid jacket using sandwich materials;
4. 4-leg jacket variant with suction buckets to substitute the piled foundation.

A sketch with reference to the points 3. and 4. is given in Fig. 2.

A central core of the research is the analysis of cost reduction potential considering either innovative support structure concepts or innovations on component level as well as optimized state of the art solutions, such as the application of new materials and load mitigation concepts. At the beginning of the project, a target cost reduction value of 20% was defined. The final cost calculations show a reduction potential between 12%-43%. It should be noted that the technology-readiness level and the level of development differ significantly between the different proposed concepts. Consequently, a direct comparison is rather difficult and the resulting cost estimates of novel concepts still have high uncertainty.

Summary

INNWIND.EU has investigated offshore wind turbines between 10 MW – 20 MW capacity with the development of several component innovations and demonstrations of some of the key technologies. Over the period of its 5-year progress, it has satisfactorily addressed all objectives that were targeted. Several of the results can be directly used by the industry.

For jacket substructures a large cost reduction potential through design optimisation, use of cost-effective materials and improved -automated-manufacturing and installation practices could be shown.

Overall the LCOE of the 20 MW offshore wind turbine was reduced by more than 30% as compared to the 2012 EWII basis of the 5 MW wind turbine. This evaluation of LCOE was primarily based on direct CAPEX savings and increase in AEP from the innovations combined with the larger capacities. Further savings in the LCOE due to OPEX reduction from lower fatigue loading and ease of maintenance is also expected. More details can be found in the final report [1].

References

- [1] <http://www.innwind.eu/news>. October 2017. LCOE Reduction for the Next Generation Offshore Wind Turbines – Outcomes from the INNWIND.EU Project

ProBeton – Development and Experimental Testing of Fatigue Resistant Concrete Foundation Structures for Offshore Wind Turbines

Leibniz Universität Hannover
Institute of Concrete Construction
(project management)
Steffen Marx, Christoph von der Haar,
Jörg Diederley

Institute of Building Materials Science
Ludger Lohaus, Julian Hümme

Partner:
Ed. Züblin AG – Central Engineering
Division

Funding: Federal Ministry for Economic
Affairs and Energy (BMWi)

Ref.Nr. 0325670

Duration: 11/2013 – 10/2016

Introduction

Current foundations of offshore wind turbines (OWT) are typically built as steel structures. Compared to a steel design, concrete constructions offer advantages in terms of manufacturing and maintenance costs as well as durability. This can be verified by the history of civil engineering structures. For example bridges and tanks are initially built as steel constructions and now mainly built as reinforced and partially prestressed concrete constructions. Even in established offshore areas (e. g. oil and gas rigs) this trend can be observed, in particular with increasing system sizes.

For OWT the fatigue resistance is of great importance. Combined stresses by wind, waves and dynamic structural behavior causes load cycles up to 10^9 . There are no reliable findings on material and structural

behavior for this high number of load cycles, especially for concrete under water. The uncertainty in determining the fatigue resistance significantly affects the economic application of concrete foundation structures for OWT.

Project Description

The collaborative research project ProBeton is funded by the German Federal Ministry for Economic Affairs and Energy. This project focuses on the fatigue behavior of large concrete foundation structures for OWT. Within ProBeton, typical fatigue loaded construction details like shell connections, changing cross sections and transition structures are investigated.

For the first time large-scale experimental tests and also small-scale tests under offshore-specific conditions are used to investigate the high cycle fatigue bearing capacity. The experimental tests are accompanied by intensive numerical simulations.

A realistic, experimentally verified description of the fatigue behavior of concrete structures for OWT provides two major advantages:

- Concrete foundation structures can be produced much cheaper and more efficient. In deeper water they also occur in competition with conventional steel structures.
- The residual lifespan of existing concrete support structures of wind turbines can be fundamentally re-evaluated. Numerical studies on a gravity foundation, which take into account the redistribution of stresses in the structure, indicate a multiple of the current design life, cf. [1]. A power production could be possi-

ble long beyond the previously defined life time for numerous OWT in the North and Baltic Sea.

A drastic reduction of electricity production costs would be possible for planned and existing offshore wind farms.

Fatigue behavior of concrete under offshore-specific conditions

A special test rig was built to investigate the influence of different environmental conditions on the fatigue behavior of concrete, cf. fig. 1. In this test rig small-scale test specimens are tested dry, wet and alternating wet/dry with respect to their fatigue behavior. Due to these experimental tests, SN curves could be derived for high strength concrete under offshore-specific conditions. Furthermore, the influence of fatigue-related damage on the chloride migration is analyzed.

Experimental component tests

A swinging system is constructed to investigate large stress ranges with high loading frequencies in large-scale experimental tests. Two unbalance exciters generate dynamic loadings with a frequency nearby the first eigenfrequency of the specimen within the swinging system. In this way, it is possible to investigate even large structural parts or sections effectively in respect to their fatigue behavior. In this process test frequencies up to 14 Hz were conducted. The specimens were prepared with strain gauges and ultrasonic transducers. These sensors were used to measure the strain development and deterioration processes of the concrete due to fatigue loading, cf. fig. 2 and 3. Different stress levels and stress ranges were considered in these experimental investigations.

Numeric structural investigations

The obtained knowledge of the experimental tests was used within the numerical in



Figure 1: Under water test rig (© Institute of Building Materials Science)

gations. They are performed on a design of a heavyweight foundation. A damage model derived from the experimental tests was implemented in numerical simulations.

Summary

Based on previous numerical investigations on wind turbines [2] and small scale experimental tests on high strength concrete specimen [3], this project investigates the fatigue behavior of real structural parts or sections

and the influence of environmental conditions (water, chlorides). The research results were used to optimize concrete foundation structures. The objective target of this project was to describe the fatigue behavior of concrete foundations more realistic and to ensure the economical use of concrete in the field of offshore wind energy. The results of this research project are published in [4] among others.

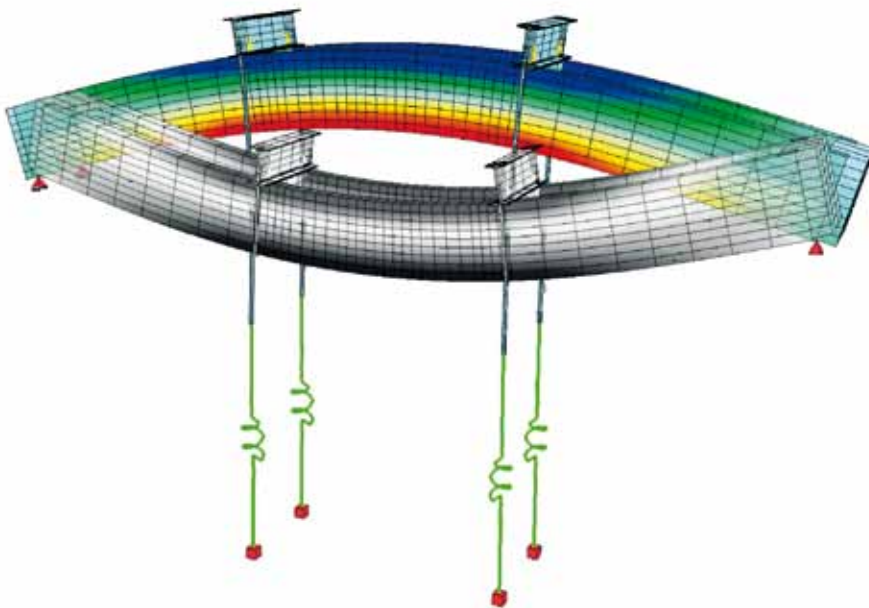

Figure 2: Vibrating test specimen (© Institute of Concrete Construction)



Figure 3: Set up of large-scale fatigue tests (© Institute of Concrete Construction)

References

- [1] Urban, S.; Strauss, A.; Macho, W.; Bergmeister, K.; Dehlinger, C.; Reiterer, M.: Zyklisch belastete Betonstrukturen, in Bautechnik 89, issue 11, pp. 737-753, Ernst & Sohn (2012)
- [2] Göhlmann, J.: Zur Schädigungsberechnung an Betonkonstruktionen für Windenergieanlagen unter mehrstufiger und mehraxialer Ermüdungsbeanspruchung, Dissertation, Institut für Massivbau, Leibniz Universität Hannover (2009)
- [3] Grünberg, J.; Oneschkow, N.: Gründung von Offshore- Windenergieanlagen aus filigranen Betonkonstruktionen unter besonderer Beobachtung des Ermüdungsverhaltens von hochfestem Beton, Abschlussbericht, Hannover, 2010
- [4] Marx, S.; Hansen, M.; von der Haar, C.; Diederley, J.; Lohaus, L.; Hümme, J.: Entwicklung und versuchstechnische Erprobung von ermüdungsfesten Gründungskonstruktionen aus Beton für Offshore-Windenergieanlagen, Abschlussbericht zum BMWi-Forschungsvorhaben ProBeton (FKZ 0325670), 2017, DOI: 10.2314/GBV:889255482

HyConCast – Hybrid Substructure of High Strength Concrete and Ductile Iron Castings for Offshore Wind Turbines

Leibniz Universität Hannover
Institute of Concrete Construction
(project management)
Steffen Marx, Christoph von der Haar,
Marina Stümpel

Institute for Steel Construction
Peter Schaumann, Luka Radulovic

Franzius-Institute for Hydraulic, Estuarine
and Coastal Engineering
Torsten Schlurmann, Arne Stahlmann,
Kim Mario Welzel

Partners:
grbv Ingenieure im Bauwesen GmbH &
Co. KG
SSF Ingenieure AG
Siempelkamp Giesserei GmbH
Max Bögl Bauservice GmbH & Co. KG

Funding: Federal Ministry for Economic
Affairs and Energy (BMWi)
Project Management Jülich (PTJ)

Ref.Nr. 0325651

Duration: 01/2014 – 12/2017

Introduction

Current substructures of offshore wind turbines (OWT) are typically built as steel structures. Compared to steel structures, concrete constructions offer advantages in terms of manufacturing and maintenance costs as well as durability. Therefore, the research project "HyConCast - Hybrid substructure of high strength concrete and ductile iron castings for offshore wind turbines" deals with the development of a novel, hybrid substructure for offshore wind turbines for water depth up to 50 m and outputs of ≥ 6 MW.

The overall objective of this project is to assess the feasibility and applicability as well as to investigate the necessary basics for planning, design and construction of a hybrid substructure. Transport and installation concepts will be developed, the risk of scour on the seabed will be analyzed and the structural behavior of the installed components and connections will be investigated.

Project Description

The research project is funded by the Federal Ministry of Economic Affairs and Energy. Several institutes of the Leibniz University Hannover, several industrial companies and engineering consultants are involved.

The innovative concept of the novel, hybrid substructure bases on combination of large-sized, thin-walled ductile iron casting knots with high-strength, lightweight precast concrete pipes. The relevant design objective is a construction optimally exploited to the properties of the used materials. To ensure high cost efficiency the entire process chain is account from the production of individual components through the inland transport, pre-assembly, the offshore transport, installation, completion up to the operation of the finished support structure.

Used materials

The mechanical properties of ductile iron, a nodular graphite cast iron material, are similar to steel. However, a significant improvement of this material is the manufacturability and increased corrosion resistance. This material provides large-scale knot structures with wall thicknesses according to the flow of forces and deliver higher fatigue resistance than large scale welded steel components.

The mainly claimed to multi-axial bending knots are connected with low-cost,

thin walled concrete precast pipes. In order to their required load bearing capacity the piles are made of high strength or ultra-high strength concrete in less stressed areas of the structure. Filled up with normal-strength mass concrete the substructures are maneuvered to its final position, aligned locally and finally lowered.

These knots of ductile iron can be produced in Germany as well as the high strength precast concrete pipes in excellent quality and with own resources in large quantities. Thus, they have an excellent potential for OWT.

Project course

To achieve the objectives the research project is divided in three work packages. In the first work package the project partners use their expertise to develop a substructure. The aim is to define the conditions that affect the design of the hybrid substructure in terms of serial production, economy, flexible use and stability. The results of the individual works were collected and presented on the screening workshop and compiled in an optimized version, called base construction (cf. fig. 1) for the following work packages.

In the second work package numerical load simulations and structural studies were carried out on the base structure. Experimental investigations of some small scale test specimen lead to better specifications within the structural design.

In the third work package the examinations concentrated on special areas of the base construction and in particular on their connection elements. For these parts numerical and experimental investigations were conducted. In addition to the numeric investigations large-scale experiments were performed.

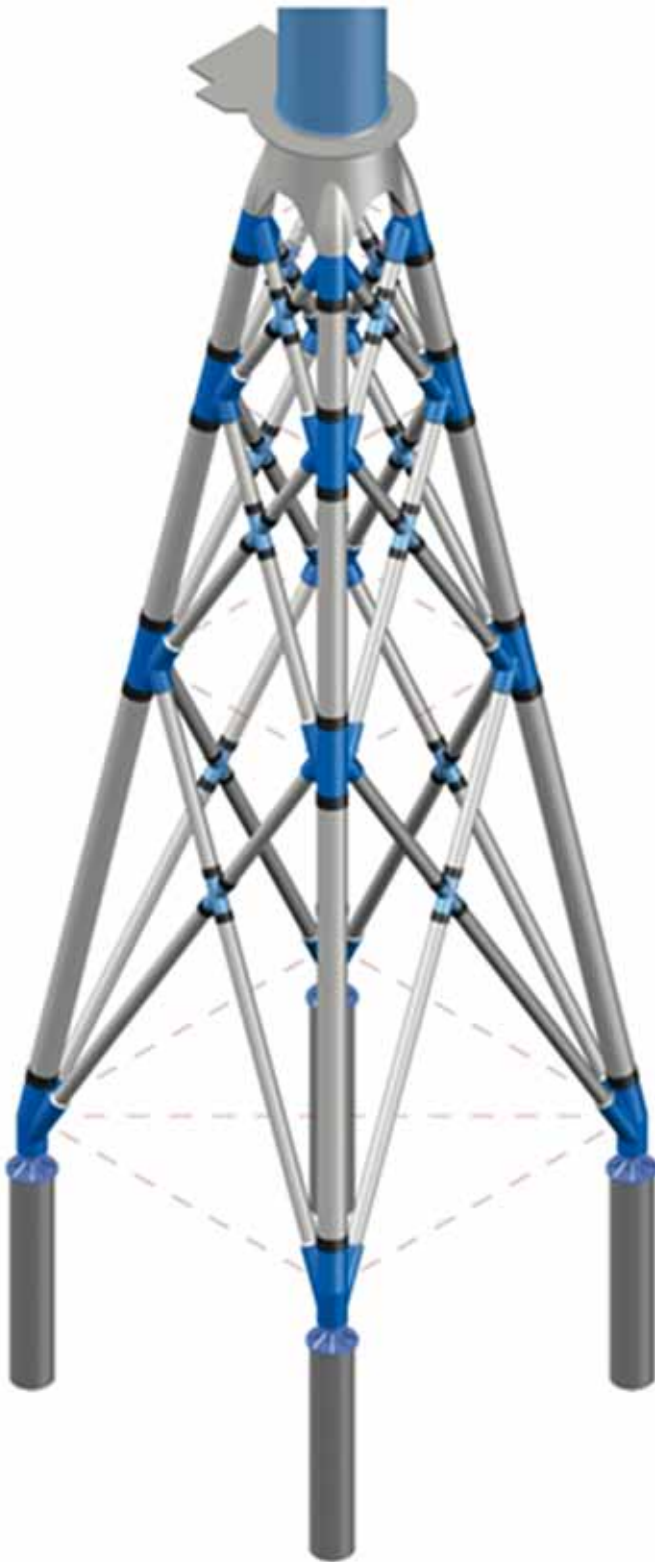

Figure 1: Base construction [3, 4]

Summary

The overall objective of the project is to assess the feasibility and applicability of the design concept and to investigate the necessary basics for planning, detailed design, and construction of this hybrid substructure. Transport and installation concepts are being developed for the substructure, the risk of scouring at the seafloor of the installed substructure is being analyzed, and the structural behavior of the installed components and connections is being examined on the basis of numerical and physical models in different levels of detail.

References

- [1] <http://www.hyconcast.uni-hannover.de>
- [2] Göthel, O. (2014): Forschungsvorhaben HyConCast – Hybride Substruktur aus hochfestem Beton und Sphäroguss für Offshore-Windenergieanlagen, 4. Ingenieurtechnisches Kolloquium des Ingenieurbüros grbv, September 18, 2014, Hannover
- [3] Stümpel, M.; Marx, S.; Schaumann, P. Seidl, G. Göhlmann, J.: An Innovative Hybrid Substructure for Offshore Wind Turbines, Proceedings of the 27th International Offshore and Polar Engineering Conference (ISOPE) June 25-30, 2017, San Francisco, USA
- [4] Stümpel, M.; Marx, S.: An Innovative Hybrid Substructure Made of High-Strength Concrete and Ductile Cast Iron for Offshore Wind Turbines, DEWEK 2017 - 13th German Wind Energy Conference, October 17./18., 2017, Bremen

Integration of Calculation Methods in the Software Tool *IGtHPile*

Leibniz Universität Hannover
Institute for Geotechnical Engineering

Mauricio Terceros, Martin Achmus

Funding: Ventus efficiens; Lower Saxony
Ministry for Science and Culture (MWK)

Ref.Nr. ZN3024

Duration: 01/2014 – 12/2019

Introduction

The offshore wind energy converters have been mainly founded on pile-supported structures. The load-bearing behavior of the axially and horizontally loaded piles has not yet been fully clarified. An intensive research is being carried out to enhance the geotechnical knowledge of the capability of pile foundations. Precise calculation methods which have been developed by the Institute for Geotechnical Engineering (*IGtH*) are highly required to standardize design procedures for an optimal treatment of the relevant effects that exist in offshore foundation structures. For such purpose, the software tool *IGtHPile* is developed simultaneously to facilitate the study of different subjects by implementing analytical methods for proposed or current calculation procedures.

Project Description

The enhancement of the state of knowledge on the load-bearing behavior of pile-supported structures is accomplished through the development of three individual issues that from the author's point of view are considered of crucial importance, among others. These issues and the role played by the software tool *IGtHPile* are briefly explained as follows.

For the design of laterally loaded piles, the p-y methods are commonly applied according to guidelines such as API and DNVGL. However, these approaches were calibrated on small-diameter piles in a homogeneous soil. Several experimental and numerical investigations refute the validity of such p-y approaches for the applications on large-diameter piles as monopiles in a nonhomogeneous soil. On this basis, an evaluation of p-y approaches is carried out through comparative studies by using three-dimensional finite element simulation to verify the reliability of their application on monopile foundation in layered sand. In this sense, the overlay method

proposed by Georgiadis (1983) for making corrections in layered soils has been successfully introduced in the modular source code of the software tool *IGtHPile*. Based on the definition of the equivalent depth, the overlay method attempts to balance abrupt changes in the course of the maximal bedding resistance of the layered soil over depth in all existing layers below the top layer as can be appreciated in Fig. 1. By doing so, the prediction effects of layered soil can be contemplated using homogeneous soil p-y approaches.

For the purpose of obtaining an integrated analysis of the load-bearing behavior of the horizontally loaded piles, the cohesive soils must also be thoroughly examined. In fact, the monopile foundations cannot be completely founded on soft soil due to its low resistance. Nevertheless, layered soils are frequently composed at least partially by cohesive soils. For such reason, studies on the validity of the currently predominantly used p-y approach for soft clay are carried out, making a clear overview of the state of the art p-y methods possible. An extensive assessment of six static p-y

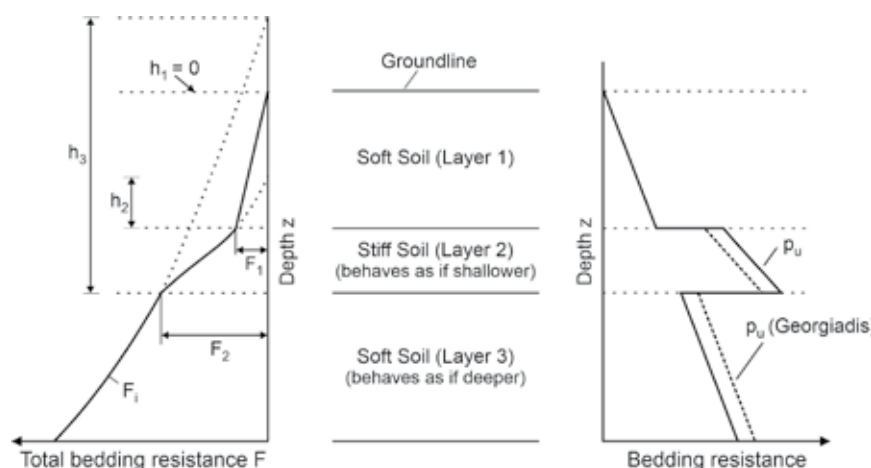

Figure 1: Calculation procedure for consideration of soil layering according to Georgiadis (1983)

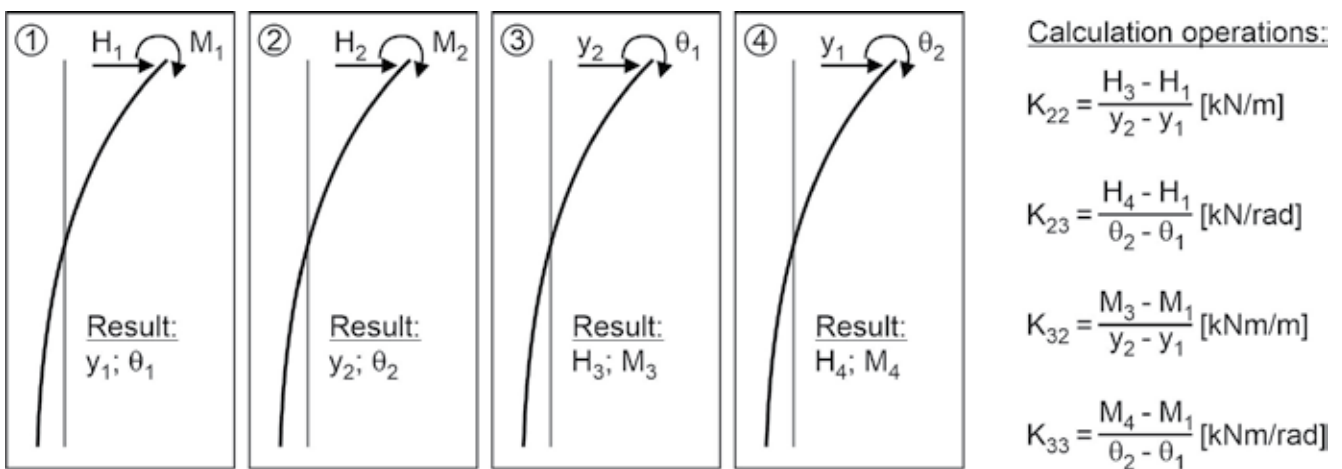

Figure 2: Calculation method for determination of the load-dependent stiffness matrixes according to Terceros (2015)

approaches has been conducted to find the deviations compared to three-dimensional numerical simulation with finite element methods. The investigated p-y methods are replicated with the help of the software tool *IGtHPile* as such the diameter-dependent formulation proposed by Steven & Audibert (1979) for consideration of large diameter pile foundation. Anyhow, the presented results are used to formulate a new, generally valid p-y approach for laterally loaded piles in soft clay.

In addition to the usual geotechnical design proofs of the load-bearing capacity and permissible deformation at the pile head calculated using the p-y methods, the foundation-soil system should have a sufficient stiffness to ensure that the eigenfrequencies of the overall structure remain within the acceptable excitation limits to avoid resonance effect resulting from the dynamic and cyclic loads. The prediction of foundation stiffness is generally derived from the result of the p-y methods. A simplification has to be taken into account by means of a single "nonlinear support node" due to the high calculation effort generated by the overall dynamic simulations. It means that the foundation stiffness is represented in the form of load-dependent stiffness matrixes, which describe the respective influence of the load components on the deformation. The load-dependent

tangent stiffness terms of the matrixes are generated using the pile design software tool *IGtHPile* which can be calculated by the calculating procedure as shown in Fig. 2. For integrated dynamic simulations of the whole structure, the results produced by *IGtHPile* can be considered to obtain a significant simplification of the calculation process in relation to the foundation stiffness.

Summary

In this report, three research issues considered in the scope of the Ventus efficiens project are presented with respect to horizontally loaded piles in which the load-bearing behavior is calculated using three-dimensional numerical simulations. Thereby, systematic comparative analyses are carried out to evaluate the reliability of the analytical solutions. Based on the object-oriented programming technique, the implementation of proposed or current calculation procedures has been successfully undertaken within the software tool *IGtHPile* developed by the Institute for Geotechnical Engineering (*IGtH*).

The conclusion can be drawn that the evaluation and analysis of analytical methods proposed either by the state of the art design or by the Institute for Geotechnical

Engineering (*IGtH*) are possible through the availability of an independent software tool such as *IGtHPile* in which the source code can be freely modified to obtain efficient implementations.

References

- [1] American Petroleum Institute (API): Recommended Practice 2GEO, Geotechnical and Foundation Design Considerations, 1th Edition, April 2011 and Addendum October 2014
- [2] Det Norske Veritas and Germanischer Lloyd (DNV GL): Offshore Standard DNVGL-ST-0126, Support structures for wind turbines, Edition April (2016)
- [3] Georgiadis, M.: Development of p-y curves for layered Soil, Proc Geotech Pract Offshore Eng, Austin, TX, USA, ASCE, pp. 536-545 (1983)
- [4] Steven, J.B.; Audibert, J.: Reexamination of p-y curve formulation, 11th Offshore Technology Conference, Paper No 3402 (1979)
- [5] Terceros, M.; Schmoor, K.; Thieken, K.; Achmus, M.: Software *IGtHPile* Version 3 & Calculation Examples Version 3, <http://www.igth.uni-hannover.de/downloads> (2015)

Ventus Efficiens – Joint Research for Raising the Efficiency of Wind Energy Converters within the Energy Supply System

Subproject II – Efficiency Enhancement of Supporting Structures

Leibniz Universität Hannover
Institute for Steel Construction
Peter Schaumann, Jan Kulikowski

Institute of Building Materials Science
Ludgar Lohaus, Corine Otto, Kerstin Elsmeier

Institute of Concrete Construction
Steffen Marx, Michael Hansen,
Steffen Hartwig

Institute for Geotechnical Engineering
Martin Achmus, Mauricio Terceros

Institute for Structural Analysis
Raimund Rolfes, Cristian G. Gebhardt,
Christian Hente

Funding: Ventus efficiens; Lower Saxony
Ministry for Science and Culture (MWK)

Ref.Nr. ZN3024

Duration: 12/2014 – 12/2019

Introduction

The ForWind research project *ventus efficiens – Joint research for raising the efficiency of wind energy converters within the energy supply system* is funded by the Ministry of Science and Culture of Lower Saxony over a five-year period. The project tackles the main challenges facing the improvement of efficiency for wind energy converters. It is subdivided into four sub-projects (SP) covering energy conversion (SP I), supporting structures (SP II), drive train and grid connection (SP III) and the integration of the whole system (SP IV).

The investigations carried out in SP II – *Efficiency enhancement of supporting structures* – concern the support structures of on- and / or offshore wind turbines. SP II is divided into five work packages (WP) (see Fig. 1).

The support structures together with the wind turbine itself build a system subjected to continuous cyclic and random loads. SP II addresses different crucial points of such a highly dynamically loaded structures start-

ing from the fatigue behavior of welded joints (WP 1) and grouted joints (WP 2), via bearing capacity of the joints of concrete tower segments (WP 3) up to the soil-foundation interaction (WP 4). Beside the studies of the different single components, a numerical investigation of the whole system based on multibody system simulations is carried out (WP 5). Large-scale experimental tests regarding the topics of the work packages within SP II are performed in the Test Center for Support Structure.

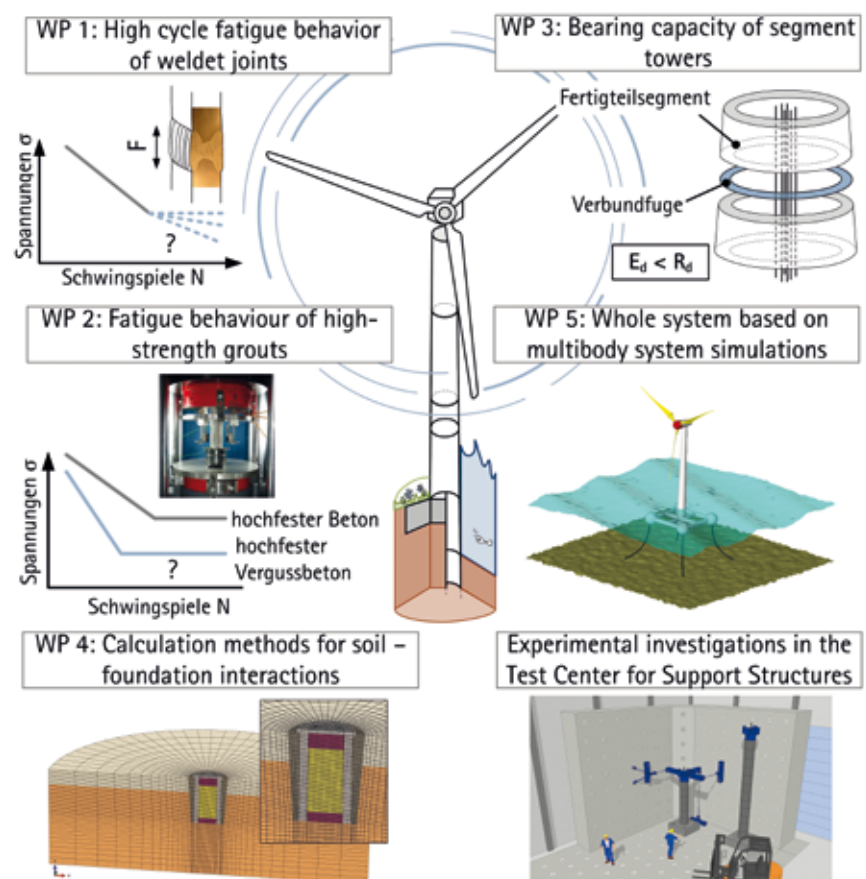

Figure 1: Project Summary: Subproject II

Project Description

Work Package 1

The fatigue limit state represents a driving factor in design of steel support structures. The fatigue design in current standards and guidelines is based on S-N curves, which are mostly based on fatigue tests up to 10^7 load cycles. The range beyond 10^7 cycles and the question of the existence of an endurance limit is of particular interest of ongoing research [1].

Experimental investigation in the very high-cycle range (above 10^7) requires testing facilities able to perform this high number of cycles within a reasonable time frame, allowing simultaneously tests on relatively large scale specimens to limit possible scale effects. For this reason a new testing device operating at a frequency of up to 200 Hz has been developed. This device is able to perform tests on axial loaded plate specimens with a thickness of up to 20 mm and a width of up to 40 mm. It allows testing with a maximum stress amplitude of 70 kN and a stress ratio of $0.1 \leq R \leq 0.5$. The operating principle of the device is based on the resonance at the level of the first natural frequency of the system composed of the testing device and the specimen [2]. The device will be used for fatigue tests of butt welded steel specimens and ductile cast iron specimens with and without notch effects in the range of 10^7 to 10^9 load cycles. At present the validation of the developed testing technology is performed.

The planned fatigue tests within WP 1 will be used to investigate the endurance limit of fatigue strength. The influence of the developed testing technology on the test results is examined. For this purpose, the obtained results are compared with the test results carried out with the conventional testing machines. Furthermore numerical and analytical models for prediction of fatigue behaviour of welded steel components will be developed. The influence of the thickness effect and the welding process as well as the use of high-strength steels will be studied. These models can eventually be used in the design process and will allow further optimization of support structures for wind energy converters.

Work Package 2

High-strength grouts are often used for the production of connections in wind turbines e. g. grouted joints. For such constructions, which are exposed to high-cyclic loadings and must be capable of bearing several hundred million load cycles during their service life, the verification at the fatigue limit state is the decisive factor.

The aim of the investigations is to determine fatigue behavior of high-strength grouts without interferences by testing technology. For this purpose, the testing interferences have to be determined. Based on these results, a time-efficient testing method for fatigue tests in an adequate testing time will be developed. The following influences could be identified as essential influences on the fatigue behaviour of high-strength grouts.

Maximum stress level S_{max} : For stress levels lower than $S_{max} < 0.75$, specimens of high-strength grout reached significantly lower numbers of cycles to failure than expected. During these fatigue tests, a considerable increase in temperature up to 70° C has been observed [3].

Load frequency f_p : Higher load frequencies, e. g. $f_p = 10$ Hz result in: Higher numbers of cycles to failure for maximum stress levels $S_{max} \geq 0.75$ and lower numbers of cycles to failure for maximum stress levels $S_{max} < 0.75$ [3]

Environmental conditions: The storage and testing under water has a significant influence on the fatigue behaviour. The numbers of cycles to failure of specimens stored and tested under water are lower than those of the specimens which were tested in dry environment. The numbers of cycles to failure of sealed specimens tend to be lower than those of unsealed specimen.

Specimen dimensions: Further investigations are necessary because the results from literature and from own experiments on this influence are not yet clear.

Based on the results of the identification of essential influences on the fatigue behaviour

of high-strength grouts, a first approach to time-efficient testing method was developed.

Therefore the test frequency is increased in a fixed time interval. First results with the testing method show that the increase in frequency and the time of each frequency depend on the used material.

Work Package 3

In work package 3, the joint carrying capacity of circular prestressed ring segments of wind turbine towers is investigated by numerical analysis and experimental tests. The current design rules [4], consisting of the classical torsion theories according to Saint-Venant for thin-walled closed and open cross-sections in combination with Coulomb's static friction law, are not correct. Depending on loading situation this leads to both, unsafe results as well as unused potential. The aim of the investigations is to develop new theories, as the current theories do not provide satisfactory results.

The first experimental investigations dealt with the determination of the coefficients of friction of smooth segment joints, which confirmed the assumption of the currently valid value from the standard. In addition, coefficients of friction were determined in dynamic tests. For these tests, the normal stress was run dynamically during the test and a coefficient of friction was determined several times. The results showed an increase of the coefficients of friction after a dynamic load. With regard to the load-bearing capacity in the whole structure, numerical investigations as well as experimental tests were carried out. The numerical investigations illustrate the need for action with regard to a realistic description of the torsional bearing capacity. The investigations prove that the currently valid theories only inadequately describe the load-bearing capacity. An analytical formulation of the existing joint bearing capacity also illustrates the inadequacy of the current approaches [5]. To confirm the identified deficiencies in the design, small-scale tests were carried out on segmented plastic pipes and a large-scale test was carried out on a segmented reinforced concrete tower at the Test Centre for

Support Structures (TTH). In the test with the segmented plastic pipes with a diameter of 20 cm and a total length of 1.2 m the numerically determined load carrying capacity values could be approximately confirmed, however the extremely pronounced creep behavior made the test difficult. The results clearly show that the current theories are not applicable to this construction. The large-scale reinforced concrete test was carried out on an approximately three-meter-high tower with a diameter of 60 cm. This corresponds to a scale of 1/10 to a real tower of a wind turbine. The measured load capacities also confirm that the current theories are not to be used to describe the torsional load capacity. However, the results also show a difference between the carrying capacities from the numerical calculations and the experimental tests. The differences are currently attributed to possible crack formation in the segments.

The previous investigations on segment joints of wind turbines in work package 3 have shown that the current theories are not correct and that new analytical solutions have to be found.

Work Package 4

Intensive research is being carried out to enhance the geotechnical knowledge of the capability of pile foundations. In this respect, the software tool IGtHPile is developed simultaneously to facilitate the study of different subjects.

For the design of laterally loaded piles, the p-y methods are commonly applied according to guidelines such as [6] and [7]. However, these approaches were calibrated on small-diameter piles in a homogeneous soil. Several experimental and numerical investigations refute the validity of such p-y approaches for the applications on large-diameter piles as monopiles in a nonhomogeneous soil. On this basis, an evaluation of p-y approaches is carried out through comparative studies by using three-dimensional finite element simulations to verify the reliability of their application on monopile foundation in layered sand. In this sense, the overlay method proposed by [8] for making corrections in layered soils has been suc-

cessfully introduced in the software tool IGtHPile.

For the purpose of obtaining an integrated analysis of the load-bearing behavior of the horizontally loaded piles, the cohesion soils must also be thoroughly examined. In fact, the monopile foundations cannot be completely founded on soft soil due to its low resistance. Nevertheless, layered soils are frequently composed at least partially by cohesive soils. For such reason, studies on the validity of the currently predominantly used p-y approach for soft clay are carried out, making a clear overview of the state of the art p-y methods possible. An extensive assessment of six static p-y approaches has been conducted to find the deviations compared to three-dimensional numerical simulations. The investigated p-y methods are implemented in the software tool IGtHPile.

In addition to the usual geotechnical design proofs of the load-bearing capacity and permissible deformation at the pile head, the foundation-soil system has to produce a sufficient stiffness to ensure that the eigenfrequencies of the overall structure remain within the acceptable excitation limits to avoid resonance effect resulting from the dynamic and cyclic loads. The prediction of foundation stiffness is generally derived from the result of the p-y methods. A simplification by a single "nonlinear support node" has to be considered due to the high calculation effort generated by the overall dynamic simulations. It means that the foundation stiffness is represented in the form of load-dependent stiffness matrixes, which describe the respective influence of the load components on the deformation. The load-dependent tangent stiffness terms of the matrixes are generated using the pile design software tool IGtHPile.

Work Package 5

There is a steadily growing interest in characterizing the dynamical behaviour of offshore wind turbines. The complexity of such mechanical system is high and very different fields are involved, e.g. structural dynamics (blades, hub, nacelle, tower, pile and drivetrain), soil dynamics, aerodynamics, hydrodynamics, controls, generation,

electronics, supply and others. From a structural point of view, it should be emphasized that some components like the blades experience very complex movements with large displacements and rotations, and in addition multiple interactions take place. The standard numerical tools are very restricted due to the inability to predict critical and supercritical behaviour. The main objective of work package 5 is the development of a parametric simulation model for offshore wind turbines, which is based on the in-house-code DeSiO. The idea is to consider the whole system comprised by the structure, soil, wind, water, controls and additional involved sub-systems as elements of a single coupled dynamical system. With this model, it is expected to analyze controlled and uncontrolled unsteady cases as well as non-linear phenomena. This is intended to carry out numerical simulations in the time domain and relies upon: i) the development of a structural model based on multibody systems and the finite element method; ii) the implementation of a soil model; iii) the adjustment and adaptation of a model based on the boundary element method for the aerodynamics and hydrodynamics; and, iv) the development of a multibody representation for the drivetrain. From 2015 to 2017, the focus was set on the most complex components, i.e. the structural module and the soil. Regarding the structural module, a very important aspect was the inclusion of geometrically exact structures within a multibody framework, including beam and shell models for composite-multilayer-hyperelastic materials. The resulting semi-discretized equations of motion and kinematical restrictions are solved in time domain by means of an energy-conserving/decaying, momentum-conserving integration. The flexible members of a wind turbine are then connected with the multibody formalism. Different analysis types to perform dynamic and static calculations have been considered, as well as the determination of eigenfrequencies and eigenforms multibody system with an adapted modal analysis.

The calculation software was validated on the basis of examples from the relevant literatures and published in high-ranking journals [9, 10]. The next steps are to consider

the interaction of the surrounding fluid with the structure using a strong coupling scheme between the multibody system, finite element method and the boundary element method.

Summary

The optimal efficiency enhancement of support structures for wind energy converters can be reached only by considering the whole system (see Fig. 2). The three-year work on the project have shown the importance of close cooperation between the different research fields. In this period the following key results have been reached:

- The new testing device operating at a frequency of up to 200 Hz for fatigue tests of butt welded steel specimens and ductile cast iron specimens has been developed
- The essential influences on the fatigue behaviour of high-strength grouts for a time-efficient testing method could be identified
- The previous investigations on segment joints of wind turbines have shown that the current theories are not correct and that new analytical solutions have to be developed.
- The evaluation and analysis of analytical methods proposed either by the state of the art design or by the Institute for Geo-

technical Engineering are possible through the availability of an independent software tool such as IGtHPile.

- A parametric model for the whole system wind turbines including interactions with the environment is further developed

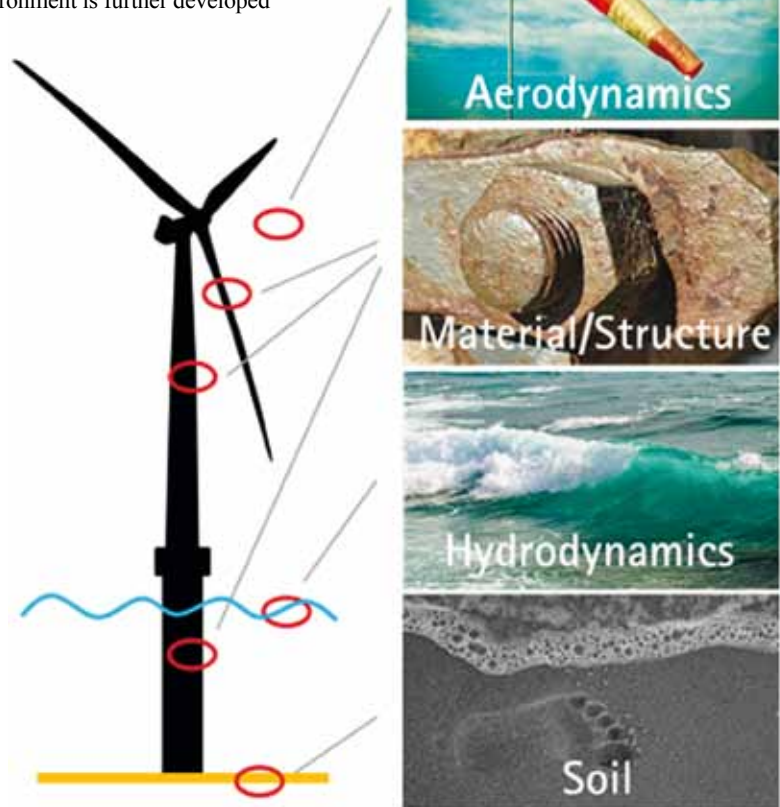

Figure 2: Wind turbines with interactions

References

- [1] Schaumann S.; Steppeler S.: Fatigue tests of axially loaded butt welds up to very high cycles, *Procedia Engineering* 66 (2013), pp. 88-97.
- [2] Alt A.: Patent DE 10204258 B4: Prüfvorrichtung zur Dauerschwingprüfung von Prüflingen 2007.
- [3] Elsmeier, K., Hümme, J., Oneschkow N., Lohaus, L. (2016): Prüftechnische Einflüsse auf das Ermüdungsverhalten hochfester feinkörniger Vergussbetone, *Beton- und Stahlbetonbau*, Jahrgang 111, Heft 4, Ernst & Sohn, 2016, S. 233-240.
- [4] Grünberg, J., Göhlmann, J. (2013): *Concrete structures for wind turbines*. Ernst & Sohn a Wiley brand, Berlin, Germany
- [5] Hartwig, S., Marx, S.: Zum Torsions-tragverhalten extern vorgespannter Kreis-segmente mit trockenen Fugen. *Beton- und Stahlbetonbau*, Jahrgang 112, Heft 11, Ernst & Sohn, 2017, S. 740–746.
- [6] American Petroleum Institute (API): *Recommended Practice 2GEO, Geotechnical and Foundation Design Considerations*, 1th Edition, April 2011 and Addendum October 2014
- [7] Det Norske Veritas and Germanischer Lloyd (DNV GL): *Offshore Standard DNVGL-ST-0126, Support structures for wind turbines*, Edition April (2016)
- [8] Georgiadis, M: Development of p-y curves for layered Soil, *Proc Geotech Pract Offshore Eng*, Austin, TX, USA, ASCE, pp. 536-545 (1983)
- [9] Gebhardt C.G.; Rolfes R.: On the nonlinear dynamics of shell structures: Combining a mixed finite element formulation and a robust integration scheme, *Thin-Walled Structures* (2017), vol. 118, pp. 56-72.
- [10] Gebhardt C.G.; Hofmeister B.; Hente C.; Rolfes R.: Nonlinear dynamics of slender structures: a new object-oriented framework, *Computational Mechanics* (2018), pp. 1–34.

Bearing Behavior of Suction Bucket Foundations under Tensile Loading in Non-cohesive Soils

Leibniz Universität Hannover
Institute for Geotechnical Engineering

Martin Achmus, Patrick Gütz

Funding: German Research Foundation

Ref.Nr. 266046182

Duration: 09/2015 – 08/2019

Introduction

The Institute for Geotechnical Engineering (IGtH) conducts research in the field of tensile bearing behavior of suction bucket foundations. This study aims at the improvement of the applicability of multipod foundation for offshore wind turbines (OWT). A main focus in this research project is the assessment of the partially drained loading condition, where negative pressure beneath the suction bucket's lid contributes to the total tensile resistance. Until now, there is no design concept available allowing the estimation of the negative pressure, which depends on the loading (magnitude and duration), permeability of the soil and the geometry of the suction bucket. If the negative pressure is not taken into account, the economic and ecologic advantages of the suction bucket foundations are diminished. However, the mobilization of the negative pressure requires certain displacement of the foundation so that the design of suction bucket foundations in partially drained condition is more driven by serviceability specifications rather than the maximum resistance.

Project Description

Physical model tests

Although several publications in terms of physical modeling of suction bucket foundations are available, these studies are not comprehensively covering the tensile

loading of suction buckets. This is why a new testing facility was erected at the IGtH, where the tensile bearing behavior can be investigated with regard to different loading conditions (Gütz et al., 2017).

In Fig. 1, results of selected model tests under various heave rates indicate a strong dependency of the tensile resistance (solid lines) and negative pressure (dashed lines) on the applied heave rate. These results confirm the findings of previous model tests (Bye et al. 1995, Kelly et al. 2006). However, the maximum tensile resistance at higher loading rates requires larger displacement of the suction bucket, which possibly exceeds the allowable heave in terms of serviceability requirements.

Besides monotonic loading, the behavior under tensile cyclic loads is investigated (cf. Fig. 2). The applied swell load has a mean load being equal to the drained capacity of the suction bucket and a load amplitude of 50% of the drained capacity (tensile load in the range of $0.5 F_{\text{drain}}$ and $1.5 F_{\text{drain}}$). The loading causes a continuous heave of the model. Furthermore, it can be seen that the increasing number of load cycles leads to an accumulation of negative pressure beneath the suction bucket's lid, which results in corresponding force $\Delta u \cdot A$ (cf. Fig. 3).

Numerical back calculation and extrapolation

A finite element (FE) model was established for investigating the suction bucket's tensile bearing behavior adopting a coupled pore water-stress-analysis (cf. Achmus & Gütz, 2016). First, the model was used for the back calculation of the physical model tests. Fig. 4 and Fig. 5 show two back calculations of partially drained monotonic model tests. The results are in acceptable agreement. Further back calculations are conducted for the verification of the FE model. The investigation of

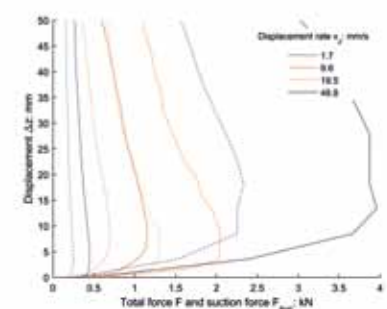

Figure 1: Vertical resistance vs. displacement for various heave rates ($L=250$ mm, $D=260$ mm)

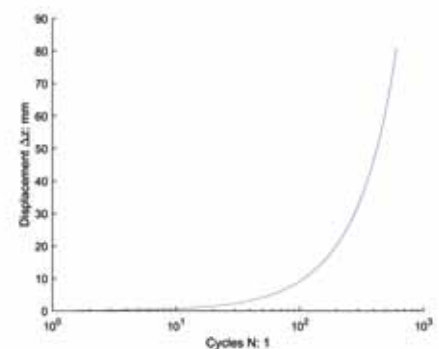

Figure 2: Displacement vs. number of cycles in physical model (Exp.) for cyclic loading exceeding the drained capacity ($L=500$ mm, $D=510$ mm)

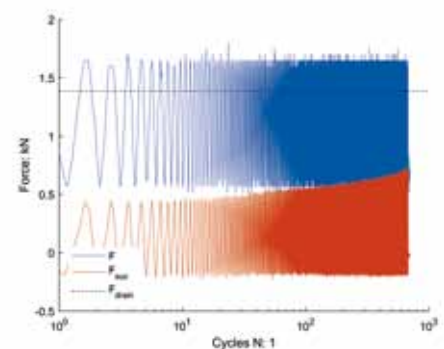

Figure 3: Vertical force vs. number of cycles in physical model (Exp.) for cyclic loading exceeding the drained capacity ($L=500$ mm, $D=510$ mm)

multiple model scales under comparable loading conditions provides insight in the scale effect. Based on these findings, the numerical model can be used for extrapolation.

Parametric studies

Parametric studies with arbitrary loading conditions are executed with the verified FE model. For instance, perfect cyclic swell loads considering various load amplitudes (from 0 kN to F_{max}) and frequencies are investigated. Fig. 6 summarizes some of these simulations for prototype dimensions ($L=D=9$ m). Obviously, load amplitudes less or equal to the drained capacity cause a vertical displacement during one cycle, but induce no continuous heave of the suction bucket. On the one hand, the suction bucket experiences an ongoing heave, as the load exceeds its drained capacity. On the other hand, the amount of displacement is significantly affected by the surplus load. In case of high load amplitudes, the interface at the suction bucket's skirt behaves plastic and is therefore predominantly defining the linear trend of accumulating heave.

A qualitative comparison of Fig. 2 and Fig. 6 confirms that a suction bucket foundation experiences ongoing heave for tensile loads in excess of the drained capacity. It is necessary to state that in case of the physical model test shown in Fig. 2 the load on the suction bucket is not totally released causing a permanent tensile force, which is in contrast to the exemplary results of the numerical calculations shown in Fig. 6.

Rheological model

Finally, the findings of the physical model tests and numerical simulation are transferred to a rheological model, where 4 springs and 1 damper represent the resistances of a suction bucket foundation (Senders 2008). The complex interaction of these components requires the definition of individual non-linear equations for every component of the model. After verification of the rheological model, it can be used as a tool for the design of suction bucket foundations. In comparison to other methods available, which only predict the

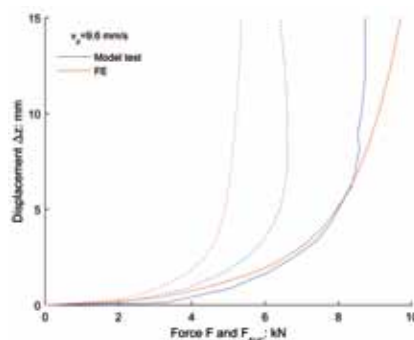

Figure 4: Vertical resistance vs. displacement in physical model (Exp.) and numerical back calculation (FE) for monotonic heave rate ($L=500$ mm, $D=510$ mm)

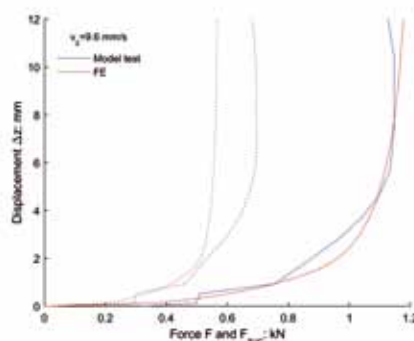

Figure 5: Vertical resistance vs. displacement in physical model (Exp.) and numerical back calculation (FE) for monotonic heave rate ($L=250$ mm, $D=260$ mm)

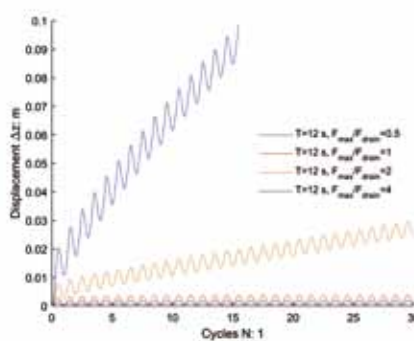

Figure 6: Displacement vs. number of cycles in numerical simulation for various cyclic loading amplitudes ($L=D=9$ m)

maximum resistance under certain loading, the rheological model describes the entire load displacement behavior. This aspect is essential with regard to the stiffness of the foundation or the assessment in terms of serviceability criteria.

Summary

The research project on the tensile bearing behavior of suction bucket foundations in non-cohesive soil provides a comprehensive overview on a complex geotechnical issue and adopts several methods for investigating the versatile interactions of this type of foundation. Based on physical model tests in conjunction with finite element simulation, the bearing behavior can be understood properly and these new insights will be used to develop a straightforward rheological model, which simplifies the design process of suction bucket foundations.

References

- [1] Bye, A.; Erbrich, C.; Rognlien, B.; Tjeltna, T. I.: Geotechnical Design of Bucket Foundations, Proceedings of the Offshore Technology Conference (OTC), pp. 869–883 (1995)
- [2] Gütz, P.; Achmus, M.; Thieken, K.; Schröder, C.: Model testing of suction bucket foundations under tensile loading in non-cohesive soil, Proceedings of the 8th International Conference on Offshore Site Investigation and Geotechnics (OSIG), pp. 578–585 (2017)
- [3] Kelly, R. B.; Houlsby, G. T.; Byrne, B. W.: Transient vertical loading of model suction caissons in a pressure chamber, *Géotechnique* 56(10), pp. 665–675 (2006)
- [4] Senders, M.: Suction caissons in sand as tripod foundations for offshore wind turbines, Computers Ph.D. thesis. The University of Western Australia, Australia (2008)
- [5] Achmus, M. & Gütz, P. (2016): Numerical modeling of the behavior of bucket foundations in sand under cyclic tensile loading, Proceedings of the 6th international conference on structural engineering, mechanics and computation, SEMC 2016, Cape Town, South Africa, pp. 2085–2091, <https://doi.org/10.1201/9781315641645>.

Development and Demonstration of a Rapid and Cost-Effective Installation Concept for Offshore Wind Turbines

Universität Bremen
Institute for Integrated Product
Development (BIK)

Klaus-Dieter Thoben,
Andreas F. Haselsteiner,
Marco Lewandowski,
Stephan Oelker, Jan-Hendrik Ohlendorf

Funding: Federal Ministry for Economic
Affairs and Energy - Homepage (BMWi)

Ref.Nr. 0325934B

Duration: 09/2015 – 12/2019

Project Description

Offshore wind energy is a key component of the German Energiewende and steadily more capacity will be installed in the future. Average wind velocities and consequently the generated power are higher offshore than onshore. Nevertheless, at the moment offshore electricity generation costs are higher. Major cost drivers are the logistics processes for installing the wind turbines. Currently, the big and heavy turbine components can be lifted off a floating transport vessel only at very good weather conditions. Consequently, companies do not charter inexpensive transport vessels to feed the components to the jacked-up installation vessel ("feeder ship concept"). Instead, the more expensive installation vessel shuttles between the wind farm and base port ("all-in-one concept").

The feeder ship concept would become economically effective if the lifting operations could be performed at harsher environmental conditions. Then, there would be more and longer weather windows. Therefore, in the joint research project "SKILLS" researchers from the University of Bremen and practitioners from the companies Senvion GmbH, Amasus Offshore B.V. and Jan de Nul NV develop technical solutions to lift wind turbine components off a floating transport vessel.

To model the lifting processes, the dynamics of the transport vessel, the turbine components and the crane are simulated numerically. These dynamics are governed by loads induced by waves and wind. We use the software ANSYS AQWA to simulate the hydrodynamic excitation of the vessel. Based on these results we analyze the lifting process using multi-body dynamics simulations. A probabilistic simulation, which in-

cludes weather data, vessel data as well as all logistical process times and costs, is used to evaluate the economic efficiency of the logistics concept.

The goal of the project "SKILLS" is the proof of a feeder ship concept, which could replace the current concept with the shuttling installation vessel. If the project succeeds, the installing offshore wind turbines will become economically more efficient and consequently the electricity generation costs will fall.

Current Project Status and Next Steps

We performed an economic analysis using discrete event simulation to determine the costs of the feeder ship concept. The analysis showed that under the assumed model assumptions the feeder ship concept can save costs compared to an all-in-one concept [1]. Further, we performed a motion analysis of the feeder ship to determine the expected motions of the loaded components. These values served as requirements in the development of novel lifting devices. Lastly, we systematically analyzed available technical solutions to describe and improve the state-of-the-art lifting process [2]. Next, we will perform offshore test. We will analyze the motions of the components blade, nacelle and hub during the lifts.



Figure 1: Copyright: Senvion GmbH 2014

References

- [1] Oelker, S., Ait-Alla, A., Lütjen, M., Lewandowski, M., Freitag, M., Thoben, K.-D.: A simulation study of feeder-based installation concepts for offshore wind farms. In Proceedings of the 28th International Ocean and Polar Engineering Conference (ISOPE 2018), International Society of Offshore and Polar Engineers (ISOPE), pp. 578–583 (2018.)
- [2] Haselsteiner, A. F., Ohlendorf, J.-H., Oelker, S., Ströer, L., Thoben, K.-D., Wiedemann, K., De Ridder, E., Lehmann, S: Lifting wind turbine components from a floating vessel: A review on current solutions and open problems. Accepted for publication in Journal of Offshore Mechanics and Arctic Engineering.

WinConFat – Fatigue of Materials of Onshore and Offshore Wind Energy Structures Made of Reinforced and Prestressed Concrete under High Cycle Loading

Subproject – Operational Effects on Concrete Fatigue

Leibniz Universität Hannover
Institute of Concrete Construction,
Institute of Building Materials Science

Steffen Marx, Ludger Lohaus

Funding: Federal Ministry of Economic
Affairs and Energy (BMWi)

Ref.Nr. 0324016A

Duration: 11/2016 – 10/2020

Introduction

Structures for wind turbines are subjected to strong dynamic loads due to wind and wave loading, which make their foundation and tower constructions susceptible to fatigue. At present, towers for wind turbines, and for offshore wind turbines even the foundations, are still predominantly built as steel constructions. The efficient application of reinforced concrete and prestressed concrete for those structures is currently being prevented by a conservative design concept against fatigue, especially for high-strength concrete. In order to improve this design concept, which dates back to the 1990s, extensive fatigue tests on concrete, reinforcing steel and their bond behavior are required. This is made possible by the 48-month joint research project "WinConFat" with the cooperation of seven university institutes, the Bundesanstalt für Materialforschung und -prüfung (BAM), the German Committee for Structural Concrete (DAfStb) and the German Society for Concrete and Construction Technology (DBV).

Project Description

The aim of the "WinConFat" subproject "Operational effects on concrete fatigue" is to close existing gaps in knowledge about the fatigue behavior of concrete for wind turbines and to gain a better understanding of the fatigue processes in concrete under cyclic loading. Only in this way the existing constraints in the design of concrete support structures for wind turbines can be reduced and a safe and economic design can be guaranteed. In the respective work steps of this subproject influences from stress redistribution, from different loading frequencies and velocities as well as the influence of water saturation and chloride transport on the strain development and the numbers of cycles to failure of high strength concretes are investigated. Another fundamental element for the fatigue design is the determination of the basic value of the fatigue strength $f_{cd, fat}$. In addition, recommendations for monitoring methods based on ultrasonic measurements are developed which can help to evaluate the remaining service life of structures for wind energy turbines. These studies are indispensable for a better transferability of laboratory-based small-scale specimens to the behavior of real structures. Thus, this sub-project provides the basis for low-cost, safe and efficient structural support structures in concrete, which can play an important role for an environmentally friendly and resource-saving, reliable and affordable energy supply in Germany.

For the influence of stress redistribution on the fatigue behavior of concrete there is only a very limited amount of test results

documented in the literature. Fatigue tests carried out on prismatic specimens show that with eccentric load application, stress rearrangements take place in the concrete compression zone. Furthermore, it can be seen that with increasing eccentricity the numbers of cycles to failure increase. These results are all based on studies on normal-strength concrete and are not readily transferable to high-strength concrete. In addition, there are only few results in the Very High Cycle Fatigue range ($N > 2 \cdot 10^6$), which is particularly important for wind turbines. In this subproject, experimental and numerical studies on the influence of stress redistribution on the fatigue resistance of real concrete components of wind turbines are derived.

The loading frequency and loading velocity have an influence on the fatigue resistance of concrete. As the loading frequency increases, usually the fatigue resistance also increases. Due to this frequency dependence, test results with different loading frequencies are not fully comparable with each other. Furthermore, wind turbines are loaded in the low-frequency range, whereas fatigue tests in the laboratory are usually carried out at higher loading frequencies. Increased loading frequencies are required in order to be able to generate the load cycles to be expected within the service life of the wind turbine. This can lead to unsafe results compared to real conditions. For this reason, this subproject investigates the influence of loading frequency on the fatigue behavior so that it can be taken into account in the interpretation of test results.

The determination of the basic value of the fatigue strength $f_{cd, fat}$ together with the definition of the S-N-curves has a decisive influence on the fatigue design. The basic value of fatigue strength includes a reduction term dependent on the concrete compressive strength. This additional reduction in fatigue stress was presumably taken from the static design, which was intended to ensure the relationship between the concrete strength tested in the laboratory and that is actually present in the structure. But this is now solved by other factors. In addition, there was a lack of practical experience with high-strength concretes in determining the basic value of fatigue strength. Concretes with compressive strengths greater than C80 were therefore not included in the development. In modern high-performance concretes the additional reduction has a dramatic effect on the basic fatigue strength $f_{cd, fat}$. The performance of modern high-performance concretes can therefore hardly be used and their use, especially in the area of high cyclic stresses, is thereby constrained. Another aim of this subproject is the statistical determination of the strength-dependent reduction of $f_{cd, fat}$. This knowledge is of great importance for the economical use of concrete in wind turbines.

Results about the fatigue behavior of water-saturated and chloride-stressed concrete are limited. The available results show that water saturation without chlorides strongly influences the fatigue resistance of concrete. There is also a dependence of the fatigue resistance on the loading frequency. It is further assumed that the compressive strength, the porosity and the tightness of the concrete influence its fatigue resistance. Also, the basic mechanisms of the fatigue behavior of water-saturated concretes are not clarified. In this context, any scale effects and the influence of seawater must be described to ensure the transferability of laboratory results on small-sized specimens to real components. The S-N-curves used for the fatigue design of offshore wind turbines are based on experimental investigations under dry conditions. S-N-curves based on fatigue tests under typical offshore conditions do not exist. These conditions can be considered only simplified by a reduction factor in

the accumulated damage sum. Whether this additional reduction is justified is unclear. There is a lack of knowledge on the fatigue behavior of water-saturated concretes, which will be closed in this subproject by experimental and theoretical investigations.

At present, there are no methods for analyzing the fatigue condition of wind turbines. In other academic disciplines continuous monitoring is an established tool for life cycle analyses. The monitoring of strains and deformations is also increasingly used. Due to the low durability of the sensors as well as the impossibility of describing degradation processes for life-time monitoring, the mentioned measured variables are only partially suitable. On the other hand, ultrasonic measurement methods in various scientific disciplines (e.g. medicine, biology) already offer an enormous performance potential. But also in other construction-related areas (e.g. steel construction, natural stone testing) or in the field of geosciences, ultrasonic measurement technology is used successfully. The application is clearly underdeveloped for concrete constructions, but especially in laboratory experiments, the method shows that it is ideally suited for condition assessment and damage monitoring. But in real component, the temperature and humidity as well as stress conditions of the component and the posthardening of the concrete can influence the measurement results. There are no universal approaches that describe the extent of these influences. An assessment for the remaining service life is not yet possible. For this purpose, theoretical and experimental investigations are carried out in order to be able to assess the fatigue process on the basis of ultrasonic measurements and to conclude by monitoring measures on the remaining service life of wind turbines. This not only brings advantages in the design of structures for new wind energy turbines, but also creates the basis for the continued use of existing support structures after the 20-year design life and thus also has a positive effect on the costs of wind energy.

Summary

On the basis of the coordinated joint research project "WinConFat" the various, as yet insufficiently researched, influences on the fatigue behavior of high-strength concretes will be experimentally determined and scientifically described. In addition, the investigations are carried out up to the load cycle range of $N = 10^7$, which has great importance for wind turbines. Furthermore, recommendations for monitoring methods based on ultrasonic measurements are developed which can help to evaluate the remaining service life of structures for wind energy turbines. The expected research results should serve as the basis for innovative, cost-effective and sustainable developments of tower and foundation structures made of high-strength concrete and ensure longer service lives of existing and new concrete structures for wind turbines.

ThermoFlight – Concept for the Development of an Optimized Maintenance and Inspection Method for Off-Shore Wind Turbines Using Thermography and SHM as Non-Destructive Testing Technologies in Combination with Unmanned Aerial Vehicles

Universität Bremen
Bremen Institute for Metrology,
Automation and Quality Science (BIMAQ)

Christoph Dollinger

Funding: BIS Bremerhavener society for investment promotion and urban development mbh

Ref.Nr. 59203/4-ZB

Duration: 01/2017 – 08/2018

Project Description

The planned expansion of offshore wind energy in Germany requires the maintenance and operation to be efficiently organized both economically and ecologically for at least 25 years for a growing number of wind energy turbines. The maintenance and testing teams are confronted with new challenges offshore. This is due to short time windows as a result of difficult weather conditions as well as high safety requirements and regulations.

Especially the rotor blade tests by industrial climbers are difficult to plan under these harsh conditions. With the objective of minimizing the use of personnel for inspections and the resulting downtimes of the offshore wind turbines, the use of non-destructive testing methods and structural health monitoring is investigated. Especially in combination with unmanned aerial vehicles, these technologies can contribute to an efficient, safe, energy and material-optimized rotor blade inspection process.

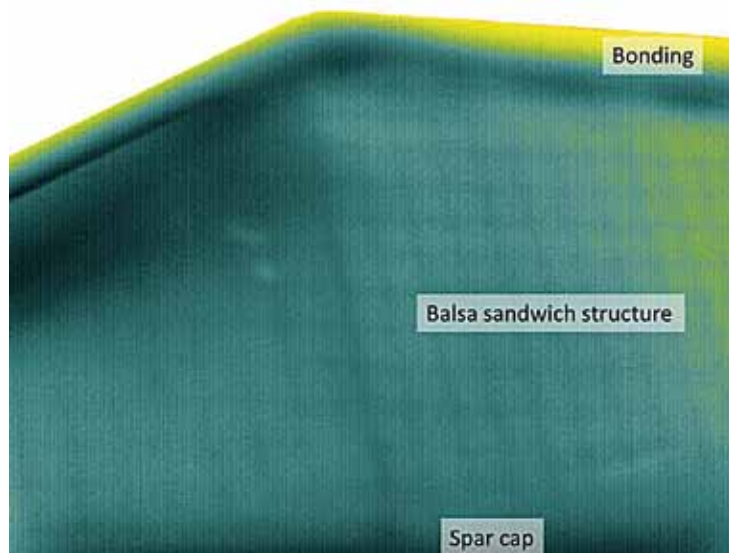

Figure 1: Thermographic image of the inner structure of a rotor blade

For the nondestructive testing of the inner structure of offshore wind turbine rotor blades the potential of thermographic images taken from unmanned aerial vehicles is investigated. The resulting requirements in terms of weight and power supply limit the variety of suitable thermographic cameras and due to that affect the available spatial and thermal resolution.

In order to characterize the method, thermographic measurements, both with high-end and light-weight thermographic systems, in standstill for deep structural (see fig. 1) and on the running wind turbine for surface near defects are performed [1]. The objective is to compensate the observed technical limitations by the use of image processing in terms of a contrast enhancement.

References

- [1] Dollinger, C.; Balaesque, N.; Sorg, M.; Goch, G.: Thermographic measurement method for turbulence boundary layer analysis on wind turbine airfoils. In: AWEA Wind Power 2014 Conference and Exhibition, Las Vegas, May 5-8, 2014.

Development of Nacelle-Based Lidar Technology for Measurement of Power Characteristic and Control of Wind Turbines (LIDAR II)

Carl von Ossietzky Universität Oldenburg
Institute of Physics
Research Group: Wind Energy Systems
Research Group: Marine Physics Group,
Research Group: Turbulence, Wind Energy
and Stochastics

Paul G. Hofmeister, Martin Kühn,
Martin Kunze, Rainer Reuter,
Matthias Wächter
(Universität Oldenburg),

Po Wen Cheng, Steffen Raach,
David Schlipf, Ines Würth
(Universität Stuttgart)

Funding: Federal Ministry for Economic
Affairs and Energy (BMWi)

Ref.Nr. 0325216A

Duration: 11/2010 – 01/2015

Introduction

The joint research project Development of nacelle-based lidar technology for power performance measurement and control of wind turbines (LIDAR II) aimed at the primary goal of developing crucial technological building blocks for future large-scale multi-MW wind turbines in offshore wind farms of power plant scale, using new and comprehensive control and monitoring strategies. It was carried out from 1.11.2010 to 31.1.2015 in the context of the accompanying research performed at the German offshore test site *alpha ventus*. Primary research goals have been the development of a robust and industrial-suited nacelle-based wind lidar, the development of lidar-based control strategies for load reduction and energy yield improvement as well as providing methods for lidar-based measurement and monitoring of the power performance

of wind energy converter systems (WEC). Cooperating partners in the project were ForWind – University of Oldenburg, Stuttgart Wind Energy (SWE) – University of Stuttgart, and Adwen GmbH. DEWI GmbH and the Federation of German Windpower e.V. (FGW) participated in the project as contractors. The project was headed by Prof. Dr. Martin Kühn, first based in the University of Stuttgart, from April 2010 on in ForWind – University of Oldenburg.

Project Description

To exploit nacelle- or spinner-based lidar measurements for the operation of a WEC, firstly different static and dynamical pro-

cedures were derived for the reconstruction of wind fields from lidar measurements and for the evolution of the wind field between measurement and rotor plane from both theoretical turbulence description and measurement campaigns. Moreover, a comparative procedure was developed to evaluate lidar measurements and optimize the scanning configuration of lidar devices. This procedure was validated using real-world measurements by estimating the rotor-effective wind speed with the help of an observer design from measurement data of a wind turbine.

Based on these findings, different lidar-based control strategies were developed and examined with respect to their potential and

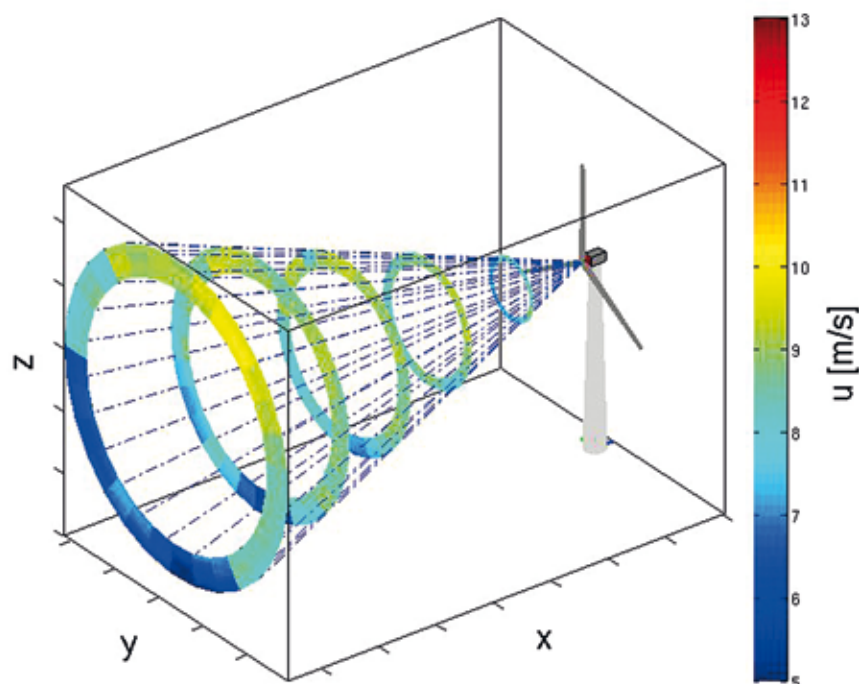

Figure 1: Measurement principle of a nacelle-based lidar. With the main direction towards the inflow, wind velocities are scanned along a trajectory. As an example a circular trajectory is shown.

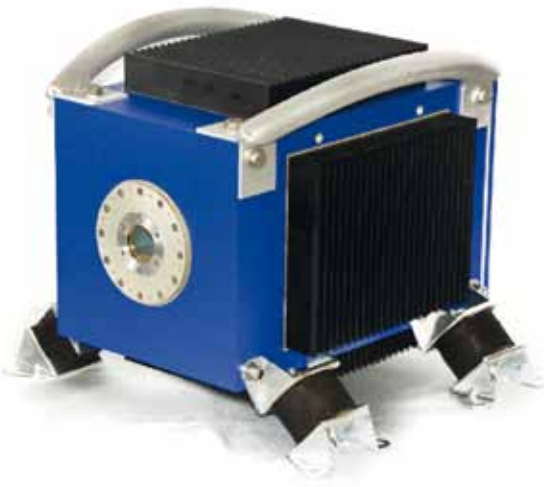

Figure 2: The robust and cost-efficient lidar system "Whirlwind 1" in the laboratory (left) and mounted offshore on AV07 in the *alpha ventus* wind farm, together with the SWE scanning lidar (right)

applicability. Especially successful was the control concept of predictive pitch control which showed evidence of substantial reduction of structural fatigue loads in simulation studies based on an Adwen WEC. To this end a simulation technique was developed which enable a realistic reconstruction of the measurement situation with different configurations, using simultaneously measured lidar and turbine data. Furthermore the potential of energy yield increase by reduction of yaw misalignment and improved control of rotational speed ("lambda-opt tracking") were investigated. For rotational speed control, real-world measurement data of a research wind turbine from a different project could be used. The investigations and experiments confirm applicability and advantages of the newly developed concepts and thus provide important technology elements for future cost-optimized multi-MW wind turbines.

Summary

Substantial results of the project LIDAR II are on the one hand the development and testing of the robust, cost-efficient, and industrial-suited wind lidar Whirlwind 1 starting from conceptual design and result-

ing in an offshore-suited prototype. With its robustness, low manufacturing costs, and its suitability for integration into the spinner of a WEC, it offers a unique combination of features. Industrialization of the lidar has started directly after the project finished.

Furthermore, dedicated methods for the lidar-based measurement of a wind turbine's power performance were developed, which provide the power curve following the principles of IEC 61400-12-1 on the one hand and the dynamical, instationary power characteristic based on 1 Hz measurements on the other hand. It was shown that direct measurement of the wind inflow by a nacelle-based lidar results in a shorter measurement time and a significant reduction of uncertainty in both cases. Based on the dynamical power characteristic, furthermore a monitoring approach was developed allowing of a continuous surveillance of the power performance as well as quick and sensitive detection of deviations.

References

- [1] Chen, P. W.; Hofmeister, P. G.; Kühn, M.; Kunze, M.; Raach, S.; Reuter, R.; Schlipf, D.; Wächter, M.; Würth, I.: LIDAR II Final Report, https://www.tib.eu/de/suchen/download/?tx_tibsearch_search%5Bdocid%5D=TIBKAT%3A860329518&cash=755cb360db4ee2b2f5d44e74f0674e6b#download-mark

GeCoLab – Test Bench for Generators and Converters Systems

Leibniz Universität Hannover
Institute for Drive Systems and Power
Electronics

Bernd Ponick, Axel Mertens

Funding: Federal Ministry for Economic
Affairs and Energy (BMW)

Ref.Nr. 0325398

Duration: 01/2012 – 09/2016

Introduction

It is done! In the last two years, our vision turned into reality: A new large-scale Universal test bench GeCoLab to investigate steady-state and dynamic properties of electrical machines and converters including converter/machine interactions is almost completed. GeCoLab stands for Generator-Converter-Laboratory. After the construc-

tion phase in 2013, technical infrastructure and electrical components were supplied in 2014. Power electronics, transformers and power distribution followed by the end of 2014. With the hall nearly filled to capacity, the installation phase started in January 2015. Everything arrived in time and fitted into place. The last items – the electrical machines – arrived in early summer 2015, then we could start off with the operation step by step. Finally, first start-up tests under power were successfully made in autumn 2015.

Project Description

The GeCoLab is a universal motor and generator test bench which enables a deep investigation of electrical machines and converters. The study of megawatt generators with or without the power electronic is an ongoing important topic due to the very different phenomena and uncertainties of large electrical drive systems. The

increasing complexity of electrical grids and rapid emerging of frequency converter-based generators encourage a much deeper study of the converter-generator interaction. GeCoLab has been created to deal with these challenges.

The system diagram (see fig. 1) gives an impression on the universal possibilities offered by the test bench facility, and this not only for the test machines and converters specifically equipped for testing, but also for specimens, be it machines or converters, provided by customers. An impression of the test bench shows the fig. 2.

Equipment parameters

- rated voltage up to 690 V
- permanent magnet synchronous machine with respective full converter
[$P_N = 1.2 \text{ MW}$, $n_N = 375 \text{ min}^{-1}$ (0 - 750 min^{-1})]
- doubly-fed induction machine with respective wind converter

Figure 1: Single line diagram

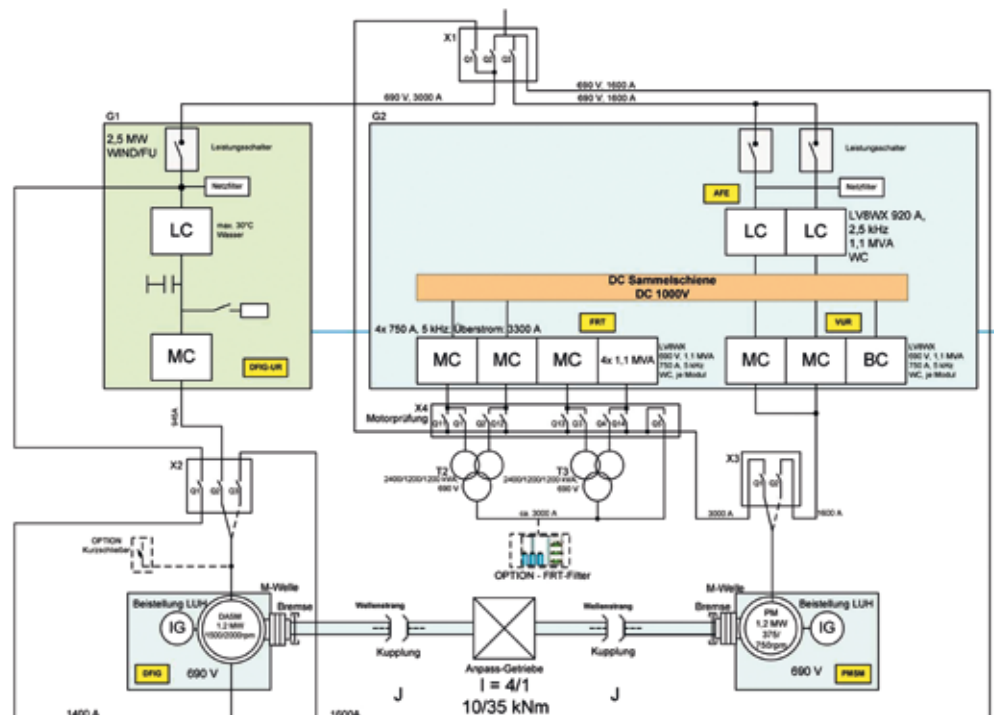

- [$P_N = 2.08 \text{ MW}$, $n_N = 1780 \text{ min}^{-1}$]
- converter-based grid modelling [$S_N = 4.4 \text{ MVA}$; unbalance, freely adjustable frequency and harmonics]
- maximum component weight 20 t
- base area of span 10 m x 4.3 m

Tests

- steady-state and transient operating conditions (Ψ , P_v , M , U , I , ECD, ...)
- temperature rise and loss distribution
- diagnostic methods

on electrical machines:

- flux distribution, end-winding fields
- current displacement, circulating currents
- Additional losses through harmonics
- Winding defects and their diagnosis

With the test bench it is possible

- Test your motor or generator prototype with different types of converters for fault diagnostics, performance validation, and analytical modelling and design method development
- Carry out investigations on our generation (PMSM and DFIG) or your components using our sensor types, such as torque, position, speed, voltage, current, flux, vibration, temperature, etc.
- Carry out investigations on both conventional and innovative converter and generator concepts including control and filter design methods. This includes investigations into dynamics and system stability, stationary and transient thermal loading, various methods of grid control and the behaviour of grid faults, such as voltage dips, symmetrical and asymmetrical short circuits.
- Carry out investigations on the converter-

generator interactions and their influence on other system components, such as bearings and gearboxes.

Summary

GeCoLab offers an optimal solution for research on the electrical drive train of wind turbines and Hydrogenerators. A quick change of components is made possible by a tensioning field and on-site 20t crane. The machine foundation is decoupled from the building by means of pneumatic spring elements. In addition, a readily accessible terminal box is installed to replace the inverter with a test object. Researchers on the mentioned topics result in an improved validation of analytical modelling, diagnostic procedures and advanced simulation model for electrical and mechanical components for a better design of generator and converter.



Figure 2: Installed test bench

Supported by:

 Federal Ministry
 for Economic Affairs
 and Energy
 on the basis of a decision
 by the German Bundestag

References

- [1] <https://www.tth.uni-hannover.de/159.html>

EVeQT– Increased Availability and Quality Optimization of Power Train Components and Gears for Wind Energy Systems

Universität Bremen
Bremen Institute for Metrology,
Automation and Quality Science (BIMAQ)

Jan F. Westerkamp, Dirk Stöbener

Funding: Federal Ministry for Economic
Affairs and Energy (BMWi)

Ref.Nr. 0325490A

Duration: 09/2012 – 01/2017

Project Description

Damages of the gear box in wind energy systems (WES) are one of the major reasons for WES downtimes. These damages are caused in part due to insufficiently manufactured gear box components (gears and bearings).

The quality inspection of these components lacks of fast geometry sensors and of adequate sensor systems for quality criteria of the surface integrity. Additionally, even if sufficient sensors are available, the traceability of the geometry measurements is not ensured due to a worldwide missing large gear standard.

Therefore, the goals of the project focus on the development of:

- a gear-like large gear standard
- optical sensors for coordinate measuring machines (CMM) to acquire gear geometries
- CMM-mountable sensors for surface integrity measurements (roughness, surface damages due to heat treatment)



Figure 1: Coordinate measuring machine measuring the large gear standard

- new strategies and evaluation methods for areal gear measurements.

These goals were mostly achieved: A large gear standard was manufactured and calibrated by the Physikalisch-Technische Bundesanstalt (PTB). Measurements of the BIMAQ during a national measurement intercomparison resulted in small deviations ($<1 \mu\text{m}$) from the calibrated values. Additionally, interferometric probes for CMMs and a new strategy for the areal gear measurement were developed and successfully tested by the project partners.

References

- [1] A. Günther, F. Balzer, I. Lindner, D. Stöbener, J. F. Westerkamp, G. Goch: Einsatz von Koordinaten-messgeräten (KMG) an Großverzahnungen. In: VDI-Berichte, Bd. 2243, pp. 139-154, 2014
- [2] F. Balzer, M. Schäfer, I. Lindner, A. Günther, D. Stöbener, J. F. Westerkamp: Recent advances in optical gear measurements. In: International Conference on Gears, Garching, Oct. 5-7, 2015, pp. 655-666
- [3] A. Günther, D. Stöbener, G. Goch: Self-Calibration method for a ball plate artefact on a CMM. CIRP Annals 65(1): pp.503-506, 2016

BladeMaker

Universität Bremen
Institute for Integrated Product
Development (BIK)

Klaus-Dieter Thoben, Jan Franke,
Marvin Richrath, Martin Rolbiecki,
Jan-Hendrik Ohlendorf

Funding: Federal Ministry for Economic
Affairs and Energy (BMWi)
Project Management:
Projekträger Jülich (PTJ)
Ref.Nr. 0325435E

Duration: 10/2012 – 03/2018

Introduction

Rotorblades for wind energy plants are predominantly still manufactured by hand. In order to achieve the goal of an industrial production, the project partners from industry and research in the joint project BladeMaker develop solutions to automate the rotor blade production. A major goal of the project is the construction and the start up of the BladeMaker demo center to test the industrial production processes and devices for automated production developed by the project consortium and thus to achieve a higher and reproducible manufacturing quality at lower manufacturing costs. Furthermore, the demo center is to be established as a national and international contact point for research and development in rotor blade manufacturing [1].

Project Description

In the Direct Textile Placement (DTP) sub-project, the Institute for Integrated Product Development (BIK) is concerned with automating the process of manufacturing the rotor blade shell. For this purpose, dry multiaxial fabrics are deposited directly into the rotor blade forming tool in a continuous deposition process. The special challenge in the development of handling technology is the flexible material characteristics of the technical textiles used. Therefore, the material behaviour during deposit and draping in multi-axially curved contours is first analysed in realistic preliminary tests. At the same time, virtual and experimental product development methods are used to develop and evaluate various technical solutions and concepts.



Figure 1: From the methodical approach to the initial operation

The further development of the solution approaches under consideration of the later integration of the devices into the BladeMaker demo center and the adaptation of the concepts to the rotor blade design will be combined in process demonstrators and initially tested and optimized in an industrial environment in the laboratories of the BIK at the University of Bremen. The handling technology developed at the BIK will then be transferred to the BladeMaker demo center and integrated into the gantry robot system [2].

Summary

As part of the "BladeMaker" project, the BIK developed a device, the DTP-Effector, for the continuous placement of non-crimp fabric layers directly into the complex shaped rotor blade mould. The DTP-Effector thus becomes one of the central tools for the gantry robot system of the "BladeMaker" demo center for automated rotor blade production. The components of the DTP-Effector are conditioned by the individual

process steps of the automated continuous non-crimp fabric depositing and consist of the base frame, the material storage unit, the gripping and draping unit as well as a large number of sensors and actuators and the associated peripherals. The BladeMaker project is funded by the German Federal Ministry for Economic Affairs and Energy within the "6th Energy Research Programme" under the grant number 0325435. We gratefully acknowledge this support [3].

References

- [1] Rolbiecki, M. (Institut für integrierte Produktentwicklung – BIK, Uni Bremen); Braun, R. (Fraunhofer IWES): BladeMaker: Industrialisierung der Rotorblattproduktion, Ingenieurspiegel 4 2014, Public Verlag
- [2] Franke, J.; Richrath, M.; Thoben, K.-D. (Institut für integrierte Produktentwicklung – BIK, Uni Bremen): Forscher automatisieren Rotorblattfertigung, MaschinenMarkt 35 2016, Vogel Buchverlag
- [3] Richrath, M.; Franke, J.; Ohlendorf, J.-H.; Thoben, K.-D. (Institut für integrierte Produktentwicklung – BIK, Uni Bremen): Effektor für die automatisierte Direktablage von Textilien in der Rotorblattfertigung, lightweight design 5 2017, Springer Vieweg Verlag

CompactWind: Increase of Wind Farm Power Output through Advanced Wind Turbine and Wind Farm Control Algorithms

Carl von Ossietzky Universität Oldenburg
Institute of Physics
Research Group: Wind Energy Systems,
Research Group: Energy Meteorology

Marc Bromm, Detlev Heinemann, Martin Kühn, Vlaho Petrović, Andreas Rott, Gerald Steinfeld, Marijn van Dooren, Lukas Vollmer, Stephan Voß

Partners:
Robert Bosch GmbH (coordinator),
eno energy systems GmbH,
Technische Universität München – Wind
Energy Institute

Funding: Federal Ministry for Economic
Affairs and Energy (BMWi)

Ref.Nr. 0329592A-D

Duration: 12/2012 – 11/2016

Introduction

During the design and the operation of a wind farm, it is necessary to consider aerodynamic interactions among turbines. Wake flow conditions are leading to substantial losses in the energy yield as well as to increases in structural loads due to larger inhomogeneity in the inflow. The effects are particularly strong at short distance behind the wake generating turbines and limit the minimum distances between turbines positioned in a wind farm.

The joint research project *CompactWind* focused on the development of turbine and wind farm control concepts for influencing the flow in wind farms to reduce the impact of wake flow conditions. The aim was to maximize the energy yield of a wind farm with respect to its area without a disproportional additional loading of the turbines. This should allow a more efficient and

more economic use of the limited number of onshore sites that guarantee high energy yields. The project was carried out in cooperation with the component manufacturer “Robert Bosch GmbH”, the turbine manufacturer and wind farm developer “eno energy systems GmbH” and the “Wind Energy Institute” of the TU München.

Project Description

In *CompactWind*, the partners worked together on six main work packages:

WP1 "Wake control", WP2 "Multifunctional IPC-Control", WP3 "Wind turbine design", WP4 "Integrated wind turbine and park control", WP 5 "Validation", and WP6 "Preparation for turbine design, wind park planning, operation and the energy supply system". ForWind scientists mainly focused on the characterization of wake behavior and on the demonstration of wake deflection in high fidelity numerical simulations (WP1) and in field experiments (WP5). Both showed a great potential for wake deflection, and thus for wind farm control, but also a significant dependency of the wake behavior on the prevailing atmospheric conditions [1,2]. In order to track and characterize wakes in the field, ForWind scientists employed lidars to measure wind velocity in two field campaigns [4], as well as in a wind tunnel campaign (WP5) [3]. For the analysis of wind turbine loads during wake deflection techniques, they developed a simulation environment by coupling a high-fidelity flow simulation code with an aeroelastic simulation code (WP2) [2]. In WP4, ForWind scientists developed a robust wind farm controller [5], which takes into account uncertainties in the wind direction measurements, and which was successfully tested in the high fidelity simulations. Finally, possibilities and challenges of applying the obtained results for the development of offshore wind farm control was discussed in WP6.

The higher level research objective of *CompactWind* was the more economic, efficient and nature-friendly use of limited onshore wind turbine sites by developing and testing new control strategies for wind turbines and farms to reduce wake induced loads and energy losses in wind farms.

In front of this background, the sub-goals included the study of possibilities to place wind turbines closer to each other and thereby reducing land occupation and increasing energy yield per unit area.

Focus of the work was the development of new interconnected control strategies at turbine level and at wind farm level to increase energy output and to reduce wake induced loads on individual wind turbines. The impact of the obtained results has been studied with respect to the economic and reliable design of wind turbines and wind farms as well as its impact on operation.

The results of *CompactWind* are based on high-fidelity simulations which reflect the interaction between wind turbines and the atmospheric boundary layer in detail, experiments using state of the art scaled wind turbine models in an atmospheric boundary layer wind tunnel, as well as field experiments on a 3.5 MW wind turbine of type *eno114*.

Important results of *CompactWind* include:

WP1: Wake control

- The possibility to deflect wakes by yaw misalignment has been verified based on Large Eddy simulations (LES) and wind tunnel experiments. LES show that the atmospheric stability has a crucial influence on the characteristics of the deflected wake and the amount of deflection.
- Individual Pitch Control (IPC) was proven to be unsuitable for wake deflection.
- A robust control system to increase energy output taking into account the inherently

dynamic inflow variation (esp. direction) has been developed.

- A short-range Lidar system has been used for wake measurements of scaled turbines in a wind tunnel first time.

WP2: Multifunctional IPC-Control

- Coupling of Large-Eddy code PALM with the aeroelastic code FAST
- Model based and inherent stable controller for IPC that is active below rated power
- Wind field and wake observer based on rotor loads have been validated in BEM simulations and in wind tunnel experiments. The wind field observer success-

fully supported the wind park control algorithm during wind tunnel tests.

WP3: Wind turbine design

- Assessment of qualification for IPC integration on wind turbine eno114
- Requirement analysis of pitch systems for IPC
- Assessment of sensor concepts for IPC to control loads in waked operation
- Study of necessity of adaptation of yaw drive for operation with IPC and yaw offset

WP4 Integrated wind turbine and park control

- Active wake deflection by yawing and the

developed robust control strategy have been tested successfully in LES for different ambient conditions

- Test of a real time, applicable, robust feed forward control structure for operation with yaw offset in the field

WP5: Validation

- Field experiments could confirm wake deflection through yaw misalignment. In addition, the impact of wind veer on wake development has been verified.
- IPC has been integrated and tested on wind turbine type eno114.
- Load measurements in standard, yaw offset and IPC operation

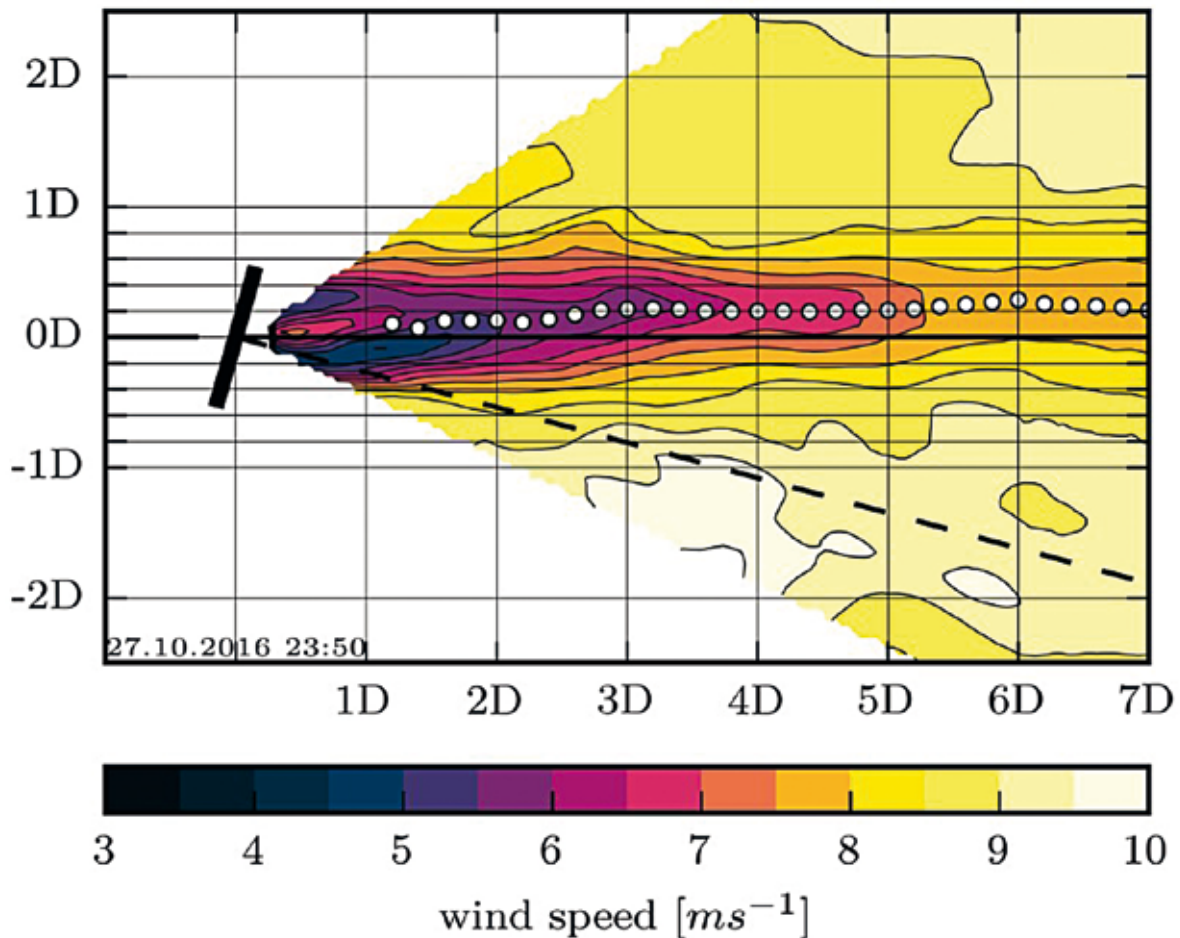

Figure 1: Wake flow measured by lidar behind an inclined wind turbine (10 minute mean value). In the wake, the wind speed is reduced to between 5 and 7 meters per second (violet to orange) compared to the undisturbed flow of about 9 meters per second (light yellow). By yawing the turbine (see dashed rotor axis), the center line of the wake (white dotted line) is deflected from the wind direction (black horizontal line). The horizontal and vertical dimensions are shown in multiples of the rotor diameter ($D = 114$ meters).

- Power measurement in standard and yaw offset operation
- Wind tunnel experiments showed that yaw misalignment can reduce loads and increase wind farm power output. For a wind farm consisting out of three wind turbines an automated control algorithm could increase total power significantly.

WP6: Preparation for turbine design, wind park planning, operation and the energy supply system

- The prevailing atmospheric stability at the wind farm location, inflow and wake characteristics of individual turbines in the wind park, and the state resp. operating point of the wind turbines have been identified as essential inputs for a wind farm control system based on wake deflection.
- Due to the still high cost for procurement and operation of necessary measurement systems and due to the absence of fully functional and ready to use alternative solutions, further steps in development have to be taken to achieve an economic wind farm control system based on wake deflection especially for small and medium size wind parks.
- It has been shown that the results can be transferred to offshore wind farms with a potential increase of energy output. The industrial application of wake deflection is still facing challenges similar to those onshore.

Summary

Within the joint research project *CompactWind*, the flow in wind farms and how it can be influenced by different turbine control concepts to increase the overall farm energy output and reduce the structural loads on the individual turbines is studied. New control strategies for the integration in commercial wind farm control systems are derived and validated in large-eddy simulations, wind tunnel experiments and in free-field flow and load measurements at multi-megawatt turbines.



Figure 2: Installation of a long-range Lidar measurement system on nacelle of eno 114 wind turbine

References

- [1] Vollmer, L.; Steinfeld, G.; Heinemann, D.; Kühn, M.: Estimating the wake deflection downstream of a wind turbine in different atmospheric stabilities: An LES study, *Wind Energy Science* 1, pp. 129-141, 2016.
- [2] Bromm, M.; Vollmer, L.; Kühn, M.: Numerical investigation of wind turbine wake development in directionally sheared inflow, *Wind Energy* 20, pp. 381-395, 2017.
- [3] van Dooren, M.F.; Campagnolo, F.; Sjöholm, M.; Angelou, N.; Mikkelsen, T.; Kühn, M.: Demonstration and uncertainty analysis of synchronised scanning lidar measurements of 2-D velocity fields in a boundary-layer wind tunnel, *Wind Energy Science* 2, pp. 329-341, 2017.
- [4] Bromm, M.; Rott, A.; Beck, H.; Vollmer, L.; Steinfeld, G.; Kühn, M.: Field investigation on the influence of yaw misalignment on the propagation of wind turbine wakes, *Wind Energy* 21, pp. 1011-1028, 2018.
- [5] Rott, A.; Doekemeijer, B.; Seifert, J-K.; van Wingerden, J-W.; Kühn, M.: Robust active wake control in consideration of wind direction variability and uncertainty, *Wind Energy Science* 3, pp. 869-882, 2018.

Probabilistic Load Description, Monitoring and Reduction of Loads of Future Offshore Wind Energy Converters (OWEA Loads)

Carl von Ossietzky Universität Oldenburg
Research groups: Wind Energy Systems;
Energy Meteorology;
Turbulence, Wind Energy and Stochastics

Martin Kühn, Detlev Heinemann,
Sebastian Ehrich, Pedro Lind,
Binita Shrestha, Gerald Steinfeld,
Juan José Trujillo, Luis Vera Tudela,
Matthias Wächter, Hauke Wurps

Funding: Federal Ministry for Economic
Affairs and Energy (BMWi)

Ref.Nr. 0325577B

Duration: 12/2012 – 08/2016

Introduction

The four project partners University of Stuttgart, Adwen GmbH, Senvion and University of Oldenburg worked together in the joint research project OWEA Loads [1], which was part of the accompanying research at the German offshore test site *alpha ventus*. Subcontractors were the University of Hannover, the University of Tübingen and DNV GL.

The project aimed at describing the aerodynamic, hydrodynamic and operational loads on offshore wind energy converters. It was intended to use the comprehensive data obtained from measurements at *alpha ventus* and the analysis of that data in previous research projects, e.g. OWEA. Moreover, the project dealt also with new questions that have to be answered in the process of designing new generations of offshore wind energy converters. One of these aspects was the description of the stochastic characteristics of loads by the means of probabilistic methods. Different concepts aiming at reducing the loads in one component of a

turbine by control algorithms that do not lead to an extensive increase of loads in other components have been developed and tested. The overall objective of all the work done in the project was to reduce the financial risks in the exploitation of offshore wind energy resources by an improved prediction of the life expectancy of turbines and extreme loads.

Project Description

It was one of the objectives of OWEA Loads to gain an improved understanding of the loads on offshore wind turbines. One of the approaches that was followed to reach this objective was to further develop the interdisciplinary modelling chain. The development of this chain started in the previous project OWEA. It allows for a detailed investigation of the interaction between the atmospheric flow and a wind turbine in specific situations. The modelling chain consists of a part that aims at providing an accurate description of the atmospheric flow, taking into account the synoptic condition and resolving the bulk of the turbulence in the atmospheric boundary layer. The flow field that is obtained from this first part of the modelling chain is then used to provide initial and boundary conditions to a second flow model that is able to give very accurate information on the response of the wind turbine to the incoming flow. In OWEA Loads two different approaches were followed to achieve improvements in the first part of the modelling chain. One approach was to use the stochastic Continuous Time Random Walk (CTRW) model in order to provide a turbulent inflow to the CFD code OpenFOAM. In contrast to other wind field models (e.g. the Mann model) the CTRW model can reproduce even higher order statistics of real wind fields and especially the intermittency of the wind fluctuations. Due to the in-

termittency large wind speed changes which might result in large loads are more frequent than predicted by a wind model that produces a Gaussian distribution of fluctuations. The second approach aiming at improvements of the first part of the modelling chain was to use lidar measured wind fields in the framework of the numerical model in order to improve the agreement between measured and simulated wind fields. This approach resulted in the development and implementation of a new turbulence recycling method in PALM. However, it turned out that it requires still considerable efforts both on the measurement and the modelling side to make this approach beneficial.

Another part of the project dealt with the question how nacelle-based Lidar measurements can help to better understand and predict wind turbine loads. A technique for the tracking of wakes by Lidar measurements was developed that carries out a fitting of a two-dimensional Gaussian function to a measured wind field. The position of the symmetry axis of the fitted function is then assumed to be the wake position. Results of the wake tracking analysis were then brought together with measured loads in order to analyze how dynamic loads depend on the wake position. In that framework it was also shown that the newly developed wake tracking algorithm can be used for an improvement of the Dynamical Wake Meandering model (DWM). Here, it was shown that it is important to feed the DWM with data obtained from Lidar measurements analyzed in a moving frame of reference instead of a fixed frame of reference to get a good agreement between measured and simulated loads.

Another task of ForWind dealt with the development of a stochastic approach that allows for predicting time series of specific loads based on time series of another pa-

parameter. This method should also be able to reproduce higher order statistics observed in measured load time series. Here, the loads were modelled by a stochastic differential equation, a so called Langevin equation. By this method measured time series of the rotor torque and tower base bending moment, respectively, could successfully be reconstructed based on a given time series of the wind speed measured by a nacelle anemometer. Moreover, it could be shown that the stochastic model derived from data measured at one wind turbine in a wind farm can be used to accurately estimate the load time series of another wind turbine of the same type in the farm when the wind speed measured at that wind turbine is available as input. This might be of special interest as it means that only one heavily instrumented wind turbine in a wind farm is required to supervise the loads felt by all wind turbines of a wind farm.

The results of the stochastic model were compared with those of an artificial neural network built up from the same data as that used for the derivation of the stochastic method. Mean values and small fluctuations are well-predicted by both methods while larger fluctuations could only be predicted by the stochastic model.

Besides attempting to improve the possibilities to predict and understand wind turbine loads, OWEA Loads dealt also with the question how by the application of control algorithms loads in certain components can actually be reduced without increasing the loads in other components of the turbine too much.

Two different approaches were followed with regards to this objective. The first approach aimed at achieving an active tower damping by coupling of a control algorithm with an oscillation analysis. The second approach attempted to gain an active reduction of lateral and longitudinal loads by a selective choice between different control concepts. In the first approach the standard control loop for the tower load reduction of a turbine is coupled with a time-frequency-analysis technique, which allows for estimating the tower oscillation frequencies.

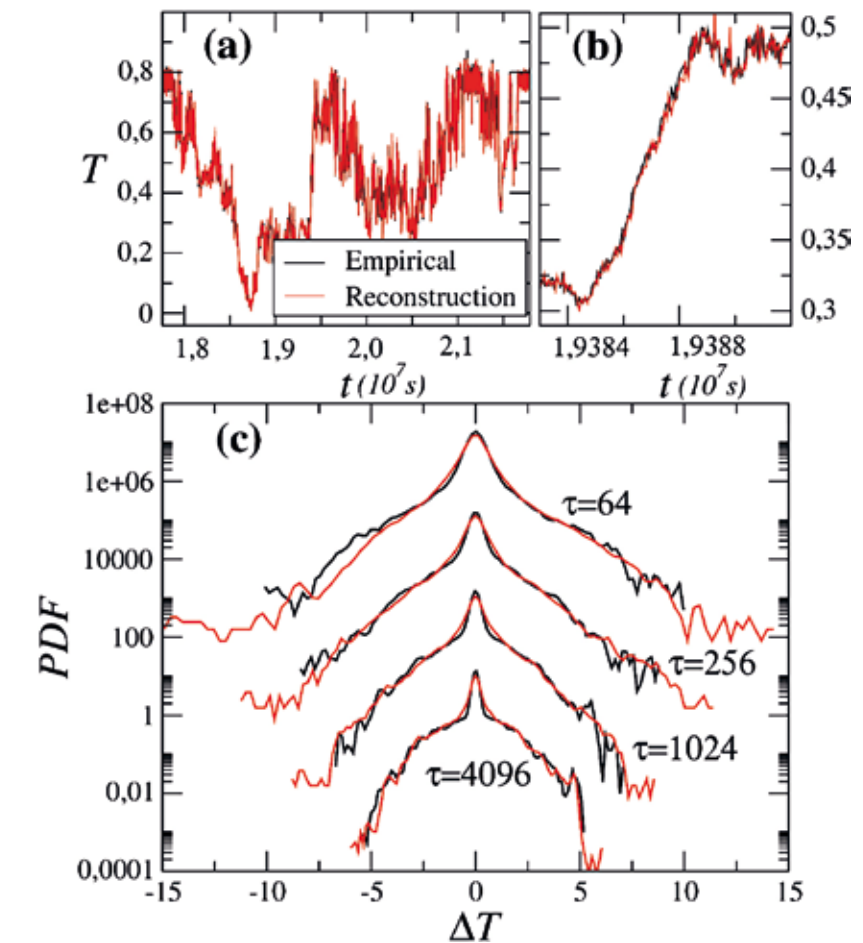

Figure 1: Measured (black) and reconstructed (red) torque. (a) time series of torque, (b) Zoom-in in (a), (c) PDFs (probability density function) of torque increments for different temporal scales.

This allows for applying a damping only in those situations in which the oscillation frequency is close to the eigenfrequency. It was shown that this approach led to 80% of the reduction that would be possible if the standard control were continuously active, while resulting in only 75% of the increase of the pitch activity.

The second approach aims at a trade-off-analysis between the reduction of fatigue loads in the tower and an increase of collateral effects in other components. Three different controllers in different combinations were studied for this analysis. With a multi-objective optimization method the most effective control concept for a certain situation was found. If a limit is set that the pitch activity must not increase by more than 60%, the loads at the tower base can

still be reduced to 78% of the possible load reduction without limitation of the pitch activity. In case that the standard deviation of the generator torque is not allowed to increase by more than 60%, the loads at the tower base can be reduced to 80% of that what is possible when there are no limits to the application of the active generator torque control. Thus, achieving a significant load reduction with simultaneously relative small collateral effects is possible.

Another part of OWEA Loads followed the path that it is still necessary to increase the knowledge on the atmospheric ambient conditions to which offshore wind turbines are exposed in order to come to improved load estimates and subsequently adapted wind turbine designs.

Therefore, a new device for probing the marine atmospheric boundary-layer up to heights of 500 m has been applied for the first time in an offshore measurement campaign. The Unmanned Aerial Vehicle (UAV), developed and controlled by staff of the University of Tübingen, was applied in 5 measurement campaigns and carried out 71 flights, each with a length of about 30 to 45 minutes. Due to the strict regulations for aerial vehicles it was not possible to carry out the originally planned fully-autonomous flights. In order to nevertheless be able to measure atmospheric conditions over the open sea, the flights took place in sighting distance from the island of Heligoland. It turned out that the usage of UAVs can be helpful to gain a detailed insight in the marine atmospheric boundary layer in single specific situations. However, for a continuous observation of offshore conditions met masts are still needed.

An aspect concerning the ambient conditions of offshore wind turbines that was studied in the framework of the OWEA Loads project was the determination of the risk of icing in the North Sea. For that purpose, a model has been developed that allows for the evaluation of the ice accretion. This model can be fed with data derived from simulations with the mesoscale model WRF. In order to get a conservative estimate of the icing risk over the North Sea, long-term simulations have been carried out with the mesoscale model WRF covering a winter with more ice days than in an average winter. According to the WRF-ice-accretion-modelling-chain icing should have occurred in 5-10% of the time at a height of 100 m over the North Sea in the winter 2010/11. Over the Baltic Sea the icing risk was found to be higher, as the occurrence of icing was predicted during 10% of the time. The analysis made clear that icing might become an even more important problem for new generations of wind turbines, as the icing risk was found to increase considerably with increasing height above ground.

Finally, also the probability of the occurrence of large wind speed maxima at low heights, so called low-level jets (LLJ) that

are suspected to be able to cause high loads on wind turbines, has been studied for the North Sea region. For that purpose, data from long-term simulations with the mesoscale model WRF for the year 2009 have been analyzed. It turned out that due to the decreased probability of stable stratifications LLJs seem to occur less often over the North Sea (10.5% of the time) than over the surrounding land. Interestingly, the differences in the number of LLJ events with cores at wind energy relevant heights is however small. Most of the LLJ cores are found in the height range between 200 and 300 m above the ground. It was found that the core height is correlated with the LLJ maximum wind speed. Moreover, the core height is correlated with the atmospheric stability. Onshore a stronger stability is required in order to get an LLJ core at the same height as at an offshore site. The analysis of the numerical results was also accompanied by an analysis of in-situ and remote sensing measurements over the North Sea. This analysis supported the results obtained from the simulations with the WRF.

The results presented above have shown that mesoscale simulations can be a valuable tool for the analysis of offshore conditions. Due to the fact that only recently data from measurement campaigns over the open sea has become available, e.g. the planetary boundary layer parameterization in the mesoscale model is solely based on data from onshore measurements. Within OWEA Loads it was therefore intended to improve the results of WRF for offshore environments by deriving an improved planetary boundary-layer scheme based on measurements and large-eddy simulations for offshore sites. As a result, the adaptation of some constants in the Mellor-Yamada-Nakanishi-Niino model was recommended.

Summary

The OWEA Loads project attempted to increase the knowledge on offshore wind turbine loads by an analysis of data from the German offshore test site alpha ventus by improving the knowledge about the atmospheric ambient conditions in the marine

environment and by developing and further improving models that provide the response of the turbine to these ambient conditions. Moreover, the project investigated several options how loads in one component of the wind turbine can be reduced by the means of a controller without increasing the loads in other components of the wind turbine too much. All three working groups of ForWind Oldenburg have been involved in the project. Highlights of the project results are:

- that a stochastic, intermittency-inducing inflow model based on continuous time processes was implemented into the CFD code OpenFOAM.
- that the benefits of an algorithm developed in the project with the objective to switch the fore-aft and side-side dampers on or off to minimize the cost function while maximizing the reduction in tower bottom bending moments could be shown.
- that actually observed load fluctuations could be well reproduced with a stochastic modelling approach and by an artificial neural network approach. The stochastic modelling approach is even able to reconstruct small-scale fluctuations well.
- that for the first-time measurements of wind and turbulence profiles were carried out over the ocean with the help of an unmanned aerial vehicle.
- that a methodology has been created with which it is possible to determine the time series of icing at a certain site based on input from a mesoscale simulation model.
- that both, numerical and experimental investigations have shown that low-level jet events are of relevance at heights that affect offshore wind turbines.

References

- [1] Bartsch, J. et al.: Probabilistische Lastbeschreibung, Monitoring und Reduktion der Lasten zukünftiger Offshore-Windenergieanlagen (OWEA Loads), Abschlussbericht, Stuttgart, 374 pages (2017)

Silicon Carbide Power Technology for Energy Efficient Devices (SPEED)

Universität Bremen
 Institute for Electric Drives, Power Electronics and Devices (IALB)

Felix Hoffmann, Nando Kaminski

Funding: Seventh Framework Programme, European Commission

Ref.Nr. 41V7736
 Duration: 01/2014 – 12/2017

Introduction

The development of a new generation of high power semiconductor devices, able to operate above 10 kV, is crucial for reducing the cost of power electronics (PE) for power transmission and renewable energies. The material properties of Silicon Carbide (SiC) clearly are superior to those of Silicon (Si) for high voltage (HV) devices. Pooling world-leading manufacturers and researchers, SPEED aims at a breakthrough in SiC technology along the whole supply chain:

- Growth of SiC substrates and epitaxial-layers.
- Fabrication of power devices in the 1.7/>10 kV range.
- Packaging and reliability testing.
- SiC-based highly efficient power conversion cells.
- Real-life applications and field-tests in close cooperation with two market-leading manufacturers of HV devices.

The main targets are cost-savings and superior power quality using more efficient power converters that exploit the reduced power losses of SiC. To this end, suitable SiC substrates, epitaxial-layers, and HV devices shall be developed and implemented in two demonstrators, a solid-state transformer and a windmill power converter. For details about the SPEED-project see [1].

Project Description

The work presented in this report focuses on the aspects of reliability of HV power devices which is the main part of the work package covered by IALB in this project. The results of this work are also published in [2]. Reliability is a major concern for power systems design. Particularly, the integrity of the junction termination is crucial for HV devices with voltages of 3.3kV and above. For this reason, a long-term high temperature reverse bias test had been conducted with a novel design of 3.3kV SiC Junction Barrier Schottky (JBS) diodes developed within the scope of the SPEED project.

SiC-JBS-Diodes are well-established in commercial applications up to 1.7kV and devices for higher voltages are under development [3,4]. However, higher voltage also increases electrical stress on the edge-termination. The High Temperature Reverse Bias (HTRB) is the standard test procedure to survey the integrity of a power

electronic device under combined thermal and electrical stress [5]. An HTRB test is conducted with novel 3.3kV SiC-JBS-Diode chips mounted on a test substrate and potted with silicone gel.

The structure of the diodes under test is shown in Fig. 1. It consists of a p-stripe design with a relatively large area of 5x5 mm². The chip design features a JTE-based edge-termination with an n+ doped channel stopper similar to the design described in [3].

The surface of the edge termination is covered with an SiO₂/polyimide stack. A total of 8 substrates with 4 chips each had been packaged for testing. Fig. 2 shows a test substrate populated with 4 diode chips covered with globtop. The chips are soldered to a direct bonded copper (DBC) substrate and mounted on a copper baseplate to increase thermal capacitance and avoid thermal runaway during testing. Two different types of package insulation were tested. An overview of the test substrates is given in Table I.

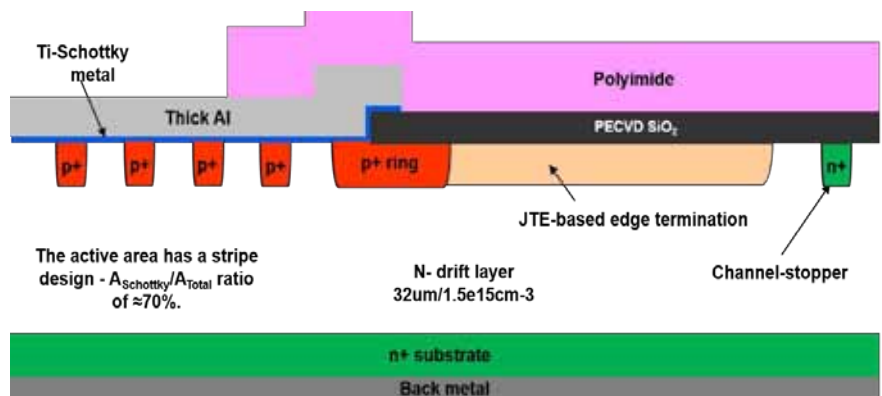

Figure 1: Structure of devices under test

Substrate	S1	S2	S4	S5	S6	S7	S8
Globtop cover	Yes	Yes	Yes	No	No	No	No
Chip count	1	2	2	3	4	3	2

Table 1

Whereas all substrates received a silicone gel potting, the chips on substrates S1 to S4 had been coated with an additional globtop covering before the silicone gel potting was applied. The globtop covering used for this test is an epoxy-based compound. It is applied to avoid direct contact of the silicone gel with the chips' surface and prevent interference of possible charges in the silicone gel with the electric field applied during HTRB. As a reference, the substrates S5 to S8 were covered with silicone gel potting only. The test is conducted with an ambient temperature of 125°C and a reverse bias of 2640V, corresponding to 80% of the diode's nominal voltage ($V_{AK,max}$) [5]. The leakage current for each substrate logged over the course of the test is shown in Fig. 3. The upper graph shows the current of the substrates with additional globtop

covering, whereas the lower graph shows the current of the substrates with silicone gel only. To verify thermal stability, the test was initialized with a slow increase in temperature from 85°C to 125°C for 500 hours. Thus, the leakage current also increases during that phase. This initialization phase is shaded in yellow in Fig. 3. One chip on substrate S2 (red line, upper graph), which was already suspicious during initial static blocking measurement, failed during this test initialization and was removed from the test batch. After the initial phase, the test was conducted for more than 5000 hours under steady state reverse bias of 2640V and constant temperature of 125°C.

Some of the tested diodes showed intrinsic deficiencies in blocking capability. It shows that an initial screening is neces-

sary to remove infant mortality sensible diodes. Those chips were not tested and also disregarded for further test analysis. The blocking curves indicate that almost all substrates exhibit a change in their reverse blocking characteristics i.e. a leakage current increase in a certain voltage range. The blocking curves are shown in Fig. 2. Both test splits trending towards the same direction concerning these changes. Hence it can be concluded that there is no significant impact of the insulation material, or respectively its embedded charge, on HTRB performance.

Hence surface charges from the silicone gel are not emerging as an important factor influencing the lifetime of a device under HTRB stress.

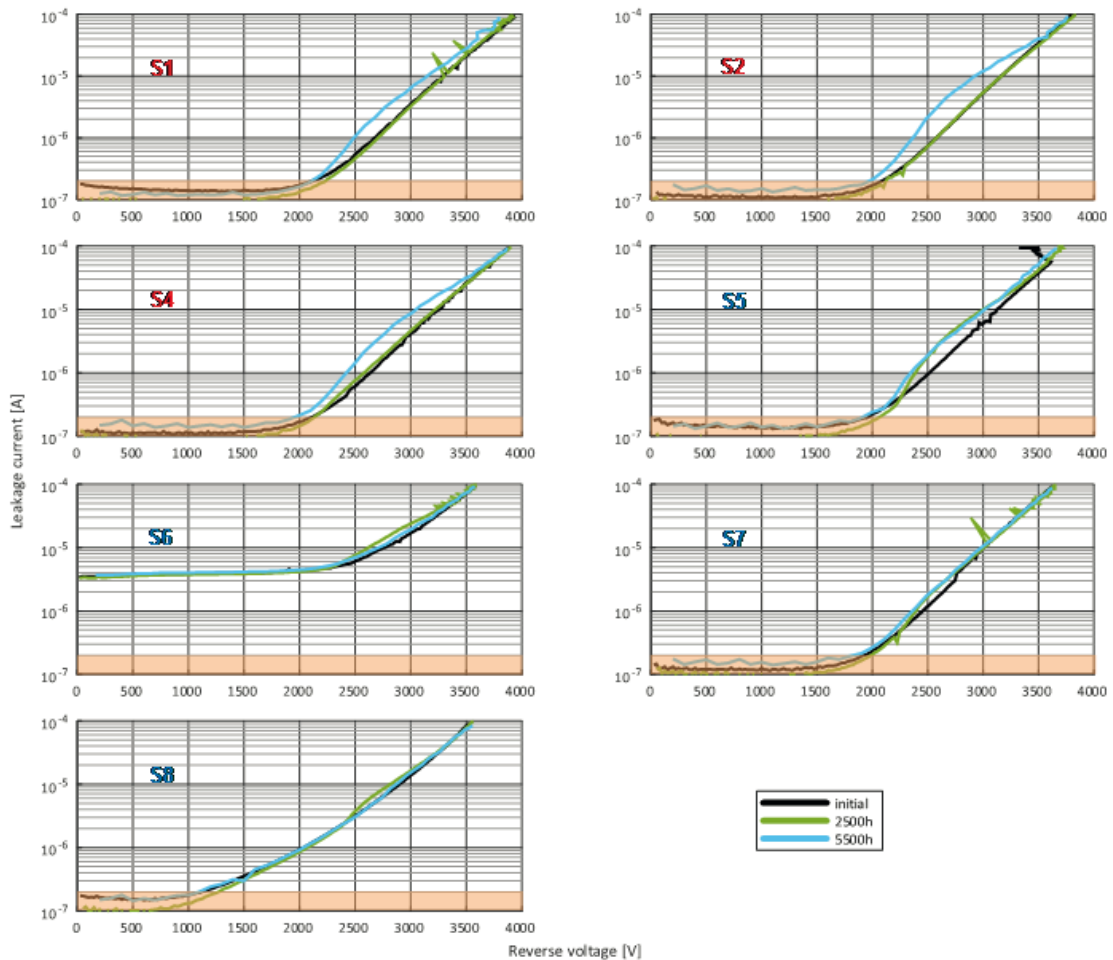

Figure 2: Blocking curves during initial measurement, after 2500h and 5500h of HTRB.

The current logs in Fig. 3 clearly indicate that both test splits show a significant general decrease in leakage current over the course of the test at high temperature, which is consistent with other publications. However, the root cause of this behavior could not be unveiled during this test.

The test was terminated after more than 5000 hours of constant HTRB stress. During our test none of the substrates had a significant increase in leakage current, which would have been an indicator for degrada-

tion or failure of a chip. Also, the intermediate measurements of reverse blocking characteristics showed that no significant degradation of blocking capability could be observed. Hence, all substrates passed the HTRB test without any failures.

Summary

This result suggests that the quality of silicon carbide HV epi material approaches the maturity level required for commercial

application. For stable and robust devices, a major challenge of silicon carbide material is the edge-termination due to its almost ten times higher critical field strength compared to silicon, and the results of this long term HTRB test show that an appropriate edge-termination design can meet the necessary stability requirements and can achieve reliable devices.

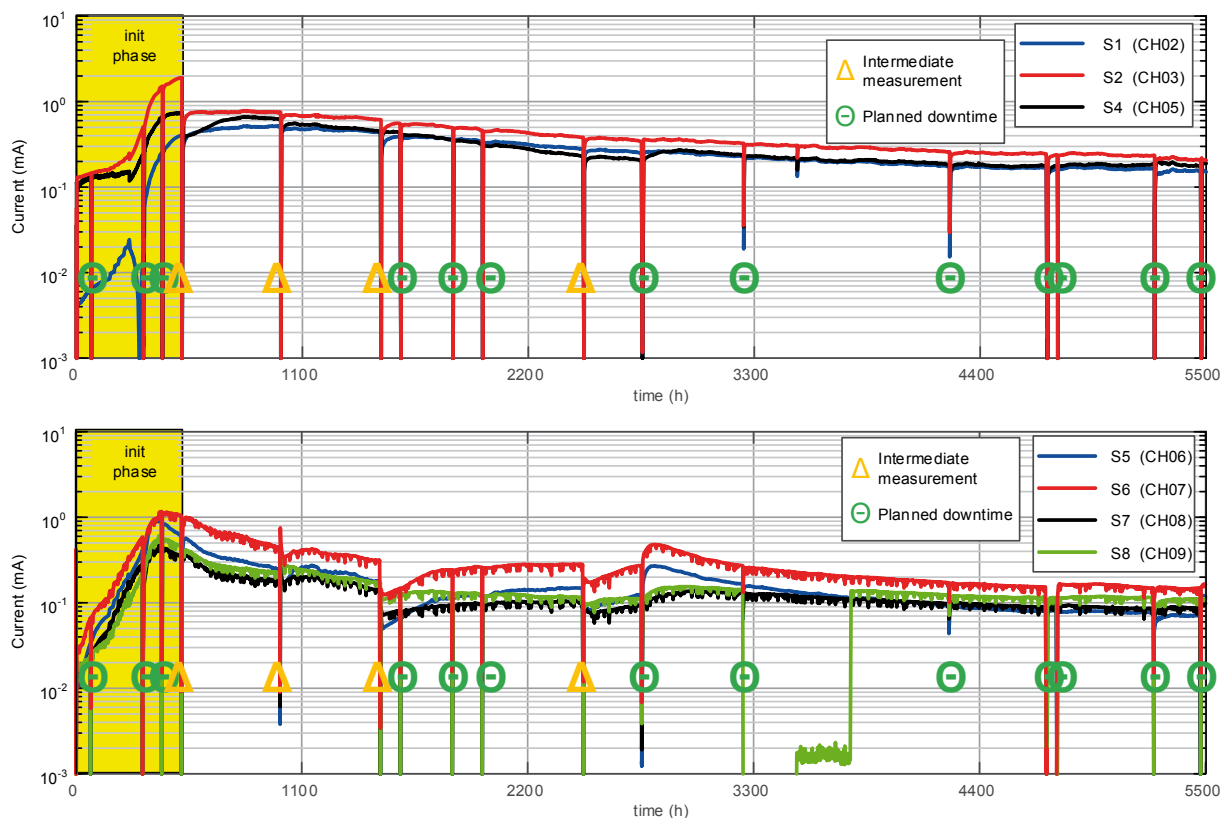

Figure 3: Leakage current log during HTRB

References

- [1] www.speed-fp7.org
- [2] F. Hoffmann et. al., 'Long Term High Temperature Reverse Bias (HTRB) Test on High Voltage SiC-JBS-Diodes', in ISPSD 2018, pp. 435-438.
- [3] A. Mihaila et al., 'Experimental investigation of SiC 6.5kV JBS diodes safe operating area', in ISPSD 2017, pp. 53-56.
- [4] J. Millán et al., 'High-voltage SiC devices: Diodes and MOSFETs', in CAS 2015, pp. 11-18.
- [5] cf. JEDEC JESD22-A108

Innovation Cluster

Power Electronics for Regenerative Energy Supply

Leibniz Universität Hannover
Institute for Drive Systems and Power
Electronics (IAL)

Marcel Moriße, Simon Weber

Funding: Ministry of Science and Culture
of Lower Saxony

Ref.Nr. VWZN2989

Duration: 09/2014 - 08/2017

This subproject focuses on ageing mechanisms in IGBT modules. Fig. 1 shows the vertical design of an IGBT module.

Due to conduction and switching losses during operation, the junction temperature in the power semiconductor (SI chip) rises. Since the temperature changes cyclically, there are ageing processes at the wire bonds and the solder joints.

To predict the lifetime of the modular design by means of lifetime models, it is necessary to know the junction temperature.

Within this subproject, an approach has been developed to measure the junction temperature while the drive is operating based on temperature-sensitive electrical parameters (TSEP). TSEPs are electri-

cal parameters of the IGBT which change depending on the junction temperature. In double pulse tests, various TSEPs were analyzed with respect to their temperature sensitivity. On-state voltage and turn-off delay time were selected as appropriate parameters. For the detection of both parameters, a low-cost electronic circuit was developed. The total component costs of the circuit are less than six € per piece for a quantity of 1,000 pieces.

At an open IGBT module, the IGBT's surface temperature as well as the two TSEPs were measured in the inverter mode. Based on the measured data depicted in Fig. 2, conclusions can be drawn on the junction temperature. When the junction temperature is known, lifetime consumption is predictable.

Project Description

WP2: Condition Monitoring, Remaining Lifetime Prediction and Preventive Maintenance Strategies

Within the scope of the Innovation Cluster Power Electronics, one research topic was to investigate the reliability of electrical converters in wind turbines. According to the research results of the project RELI-AWIND (2011), the main failure sources are the pitch system and the frequency converter. Ageing mechanisms of the IGBT modules and insulation defects are the most important failure causes in frequency converters. The aim of the meanwhile completed Innovation Cluster Power Electronics, which was funded by the Land of Lower Saxony and by Fraunhofer-Gesellschaft, was to identify the causes and develop approaches for improvements and failure prediction. Within the project, IAL has worked in close cooperation with Fraunhofer IWES in Hannover.

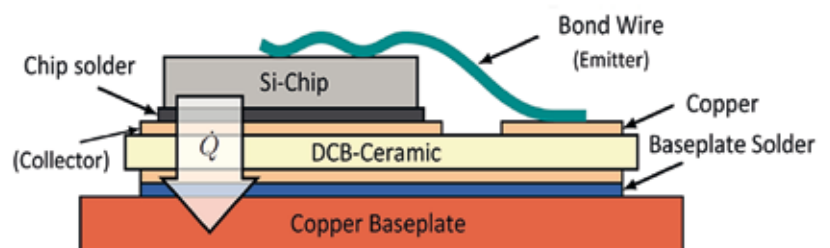

Figure 1: Vertical design of IGBT module [1]

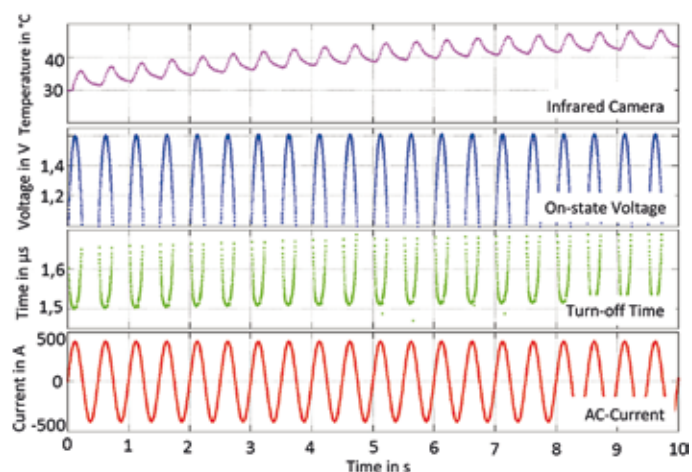

Figure 2: Measurement of on-state voltage and turn-off delay time

WP3: Drive Train Modelling to Determine Harmful Influences on Converters in Wind Turbines

In this subproject of the Innovation Cluster, the aim was to identify harmful influences during operation by the development of wind turbine models with typical drive train topologies and converter concepts which consider the specific properties of the subsystems (rotor, drive train and electrical system including grid) in an overall model.

In the next step, a lifetime algorithm (Fig. 3) was applied to evaluate the effects on the power semiconductors. The algorithm is based on an accurate thermal model of the converter modules and on current empirical investigations concerning their expected lifetime depending on specifically parameterizable power cycles.

One research result proves that typical and partially vast simplifications are permissible when modelling the overall system, in order to determine the thermal stress on the power semiconductors. Operating point dependent load cycles due to different wind speeds in the range of several seconds have a considerably larger impact on thermal module stress than high-frequency wind turbulences or drive train vibrations. In contrast, active control strategies can have a more relevant influence on lifetime.

Individual pitch control (IPC) to reduce magnitude-dependent asymmetrical bending moments at the rotor blade bearings increases for example the load on the pitch converter. Due to typically oversized pitch drives, these surplus loads might not be crucial for a premature failure of the pitch converters. Similar effects on the

main converter can be expected from active torsional damping (ATD) of the drive train through additional generator torque. However, since the main converter as a significant cost driver is normally rather not excessively oversized, it is important to consider the effective impact of ATD in the design phase. Another point of research was the consideration of control methods to mitigate the thermally particularly critical generator synchronism in systems with doubly-fed induction machine. Their consideration can play an important role when designing power modules for the generator converter. Fig. 4 shows the avoidance of the largest lifetime-significant temperature differences of a diode when the magnetizing reactive power for the generator during synchronism is partly supplied by the grid converter.

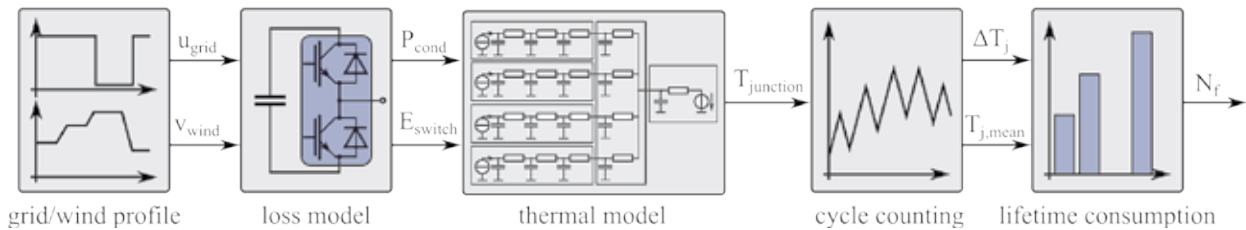

Figure 3: Schematic procedure when calculating the lifetime consumption of the single converter semiconductors

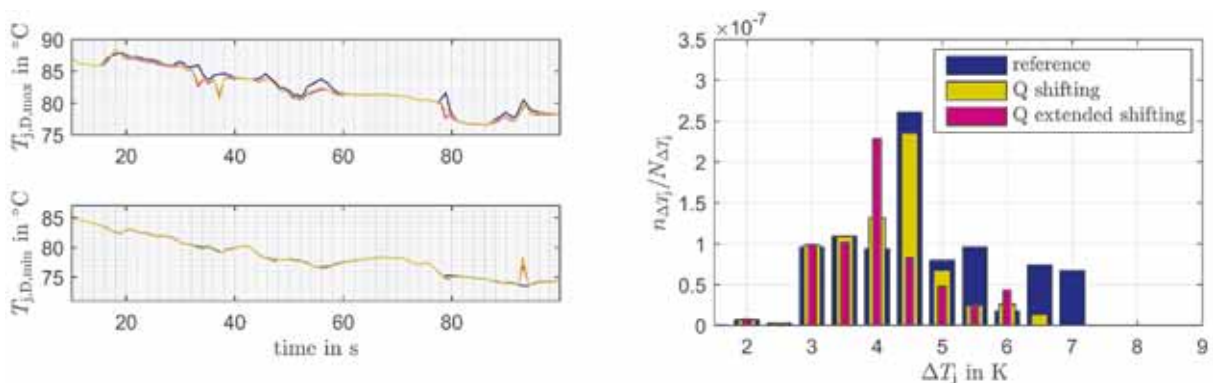

Figure 4: Thermal relief of a diode of the generator converter by reactive power supply of the grid converter in generator synchronism

References

[1] M. Schulz, Vervielfachung von Lebensdauer und Leistungsdichte mit IGBT5 & .XT, ELEKTRONIKPRAXIS Leistungselektronik & Stromversorgung, September 2015)

Manufacturer-independent Retrofitting and Evaluation of the Remaining Life Time of Power Electronic of Wind Turbines with DFIG (WEA-Retrofit)

Universität Bremen
 Institute for Electric Drives, Power Electronics and Devices (IALB)

Holger Groke, Wilfried Holzke, Alexander Brunko, Nando Kaminski, Bernd Orlik, Christian Zorn

Funding: German Federal Ministry of Economic Affairs and Energy

Ref.Nr. 0325758A-D

Duration: 12/2014 – 08/2018

Introduction

While predicted maintenance for drive trains and mechanical parts is already a state-of-the-art procedure to reduce downtimes, this procedure is currently not available for the converter system. Failures due to degradation of power electronics, as part of the converter, cause significant main-

tenance cost [1]. The experience of wind farm operators shows that downtimes due to failing power electronics start dominating failure statistics. To avoid unplanned downtimes a prediction of the remaining lifetime would be extremely helpful.

Project Description

The aim of the project is to increase the service life of the power electronics in wind turbines and to enable the prediction of failures. Based on an online evaluation of electrical parameters measured on wind turbines in operation, a model-based calculation of the expected remaining lifetime of the power electronics shall be achieved. The concept developed for the preventive maintenance of power electronics is then tested on a functional model as a laboratory setup by retrofitting older systems with new system services and avoiding recertification of the system, independent of the manufacturer. Within the scope of this

project, the core responsibility of IALB is the development of appropriate measurement equipment, condition monitoring in the field, reliability testing in the lab, and lifetime modelling.

The required field-data is logged over years in an active, commercial wind farm in northern Germany between Bremen and Hamburg. Seven measurement units and special electronic systems, developed by the IALB at the University of Bremen, were used to measure and analyse the stress of the power electronics of seven wind energy plants with high resolution 24 hours a day and 365 days a year. The huge amount of data is recorded and processed by a combination of DSP, FPGA and high-end IPC devices. One of the built up measurement systems is shown in Fig. 1. Currently, the flexible and modular system allows sampling of up to seven channels simultaneously with 16 Bit at 50 kHz or up to 18 channels if lower frequency is sufficient. An extension board with a FPGA, con-

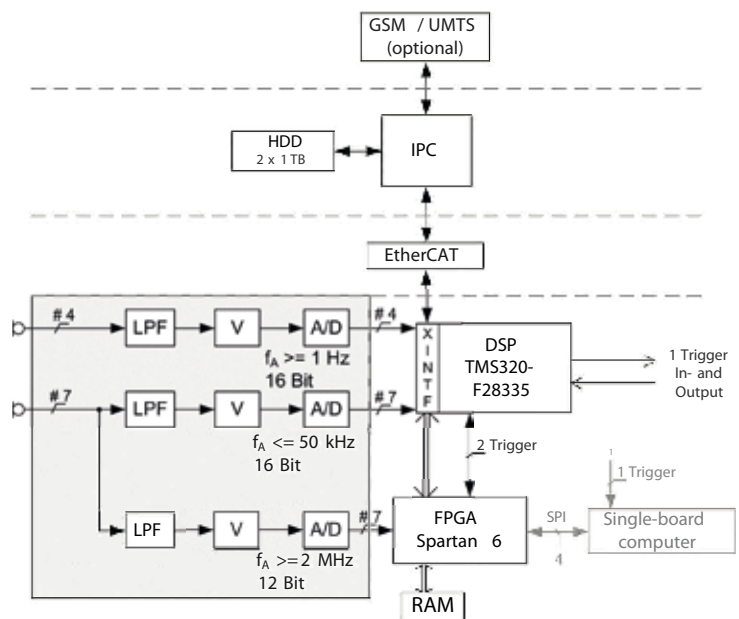

Figure 1: Measurement system developed at IALB (left), structure of the measurement system (right)

nected to a fast RAM, with seven channels with 12 Bit at 10 MHz, was added for real-time signal analysis and data compression. Furthermore, there are four channels for humidity and temperature measurements available. All raw data is transferred to the IPC and stored with a timestamp.

There are different approaches to extend the measurement system towards a monitoring system. Methods based on online signal measurements use e.g. the Collector-Emitter-voltage [2] or modified gate drivers [3] to estimate the virtual junction temperature T_{vj} , as the most meaningful parameter. In this work, a model-based approach has been chosen. As described in Fig. 2, information about the used power electronic devices (Insulated Gate Bipolar Transistor (IGBT), diode) and the structure of the whole package including the cooling system is necessary. The required parameters were determined by offline laboratory measurements similar to the approach in [4]. Mains and DC-link voltages, currents and temperatures have to be measured in real-time. While look-up tables and solv-

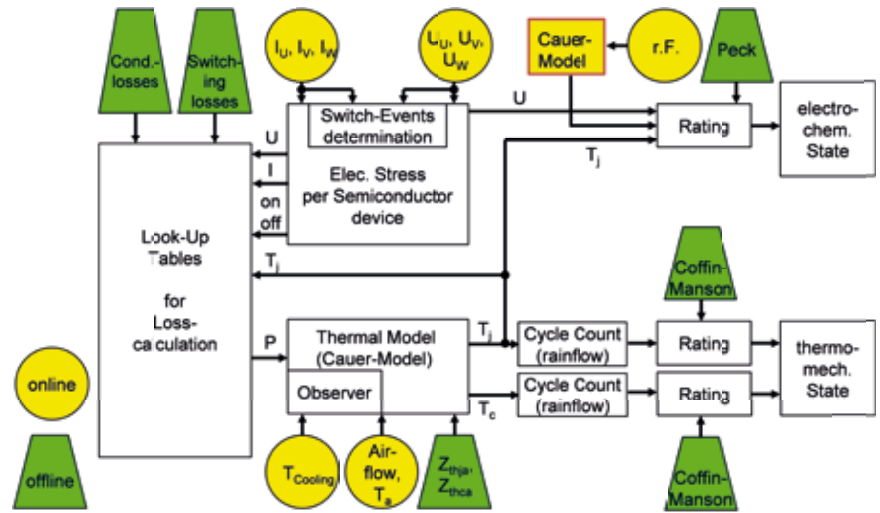

Figure 2: Model to estimate the remaining lifetime

ing a Cauer-Model is straight forward, a real-time capable version of the rain-flow count, to analyse the temperature cycles, is not trivial. Finally, the models can reveal the thermo-mechanical and the electro-chemical status of the semiconductor module.

Fig. 3 shows current and temperature measurements of a wind energy plant for a period of two weeks, recorded by the data acquisition system. The first plot shows one phase of the grid current, the second shows the heat sink temperature in front of

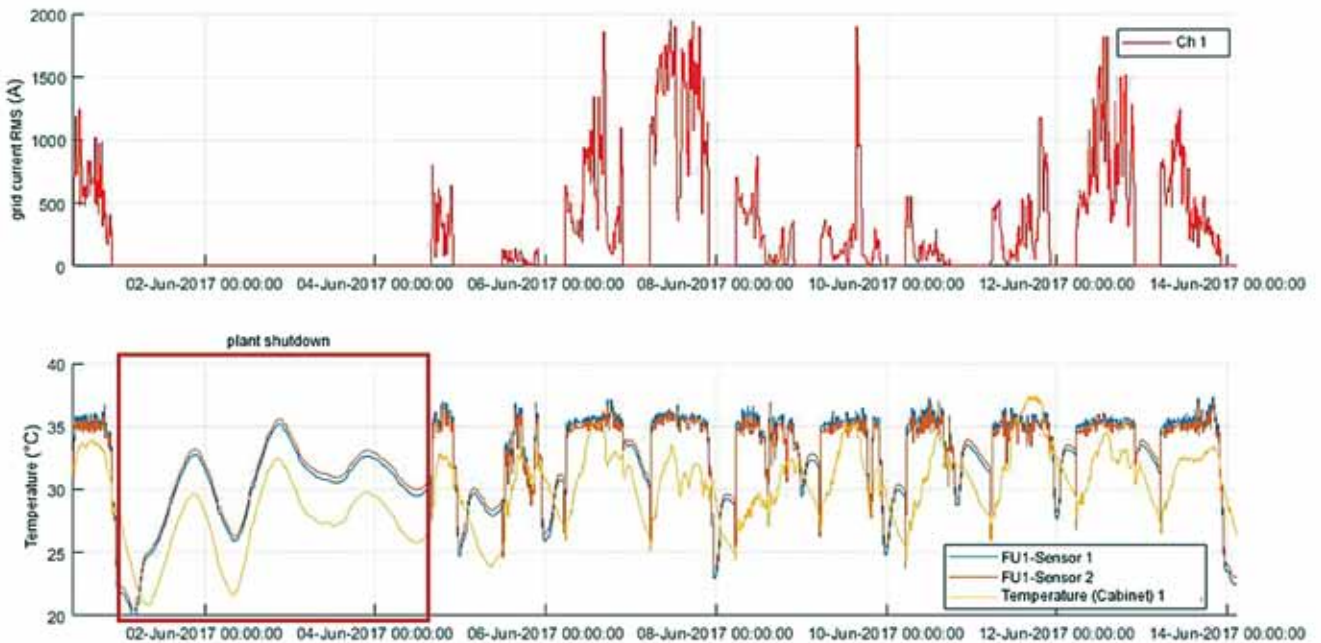

Figure 3: Current and temperature measurements for a period of two weeks

and behind an IGBT device as well as the temperature in the cabinet.

As expected, the cooling system keeps the temperature of the devices at a given set point while the wind energy plant is in operation. If the wind energy plant is offline, e.g. 1st to 4th of June (box in Fig. 3), the temperature of the heat sink follows the temperature of the environment. These temperature cycles must also be considered for calculating the lifetime. While the highest temperature at the junction is the result of the conduction losses, the minimum temperature is applied from the outside (ambient) of the module. This leads to the requirement that the condition monitoring system has to run independently of the wind energy plant, technically speaking for the whole lifetime of the power electronic device. This has to be taken into account when selecting a digital signal processor and implementing the rainflow count, due to limited memory for storing the cycles.

Feeding the measured data like in Fig. 3 into the lifetime estimation models yields useful lifetimes of far beyond 100 years, i.e. the modelled degradation mechanisms would hardly lead to any failure. Admittedly, the wind park under investigation is rarely running at rated power and the temperature cycles are rather small. Furthermore, no special events that would have caused significant live time consumption were detected. Thus, the operational conditions in the investigated wind park have to be considered as rather smooth and are not ideal to challenge the power electronics.

Summary

A flexible measurement system for long-term data recording and processing was established. The recorded data is utilised to analyse the stress of power electronics of wind energy plants connected to the grid. Based on this input and reliability models of the power semiconductors the remaining lifetime of the electronics can be predicted. The accuracy of the results strongly depends on the precision of the model parameters. Therefore, the parameters have to be adjusted for each new IGBT based on extensive laboratory experiments. However, the results obtained so far suggest that neither the thermo-mechanical nor the electro-chemical degradation nor special events in the grid limit the useful service life of the investigated wind energy plant. This would direct the search for the root causes of indeed occurring failures away from the classical failure mechanisms towards “new” effects, but this is subject to further evaluation.

References

- [1] Fischer, K.; Wenske, J.: Towards reliable power converters for wind turbines: Field-data based identification of weak points and cost drivers, EWEA 2015, Paris
- [2] Bęczkowski, S.; Ghimre, P.; de Vega, A. R.; Munk-Nielsen, S.; Rannestad, B.; Thøgersen, P.: Online Vce measurement method for wear-out monitoring of high power IGBT modules, EPE 2013, Lille
- [3] Denk, Bakran, M. M.: Health-Monitoring of IGBT power modules using repetitive half-sinusoidal power losses, PCIM Europe 2016, Nuremberg
- [4] Zorn, C.; Kaminski, N.: Temperature–humidity–bias testing on insulated-gate bipolar transistor modules, IET Power Electronics, vol. 8, iss. 12, pp. 2329-2335 (2015)

BisWind – Component Integrated Sensor System for Wind Energy Systems

Universität Bremen
Bremen Institute for Metrology,
Automation and Quality Science (BIMAQ)

Michael Sorg

Funding: Federal Ministry for Economic
Affairs and Energy (BMWi)

Ref.Nr. 0325891D

Duration: 01/2015 – 07/2019

Project Description

Drive trains of wind energy systems experience a broad range of dynamic loads. Transient torque reversals originate in power loss and emergency stops, start cycles and in sheer winds and turbulence. The subsequent failure of bearings and gearboxes result in over 50 % of wind energy. To improve the design of drive train components with precise load cycles, precise and long-term measurements are required.

Torque sensors are currently used only sporadically and not in volume production. Direct measurements of loads are not available for most parts of the drive train, especially from the inside of the gearbox. Data over the lifetime are scarce and correlations to failure events are thus limited to a few cases.

The cooperative research project develops a component-integrated measuring system. The key design aspects are measurement of torque, temperature, vibration and rotational speed with a sensor that is resistant to aging and aggressive media, and is self-sufficient.

The scientific and technical objectives cover a broad range beginning with the process development for direct coating and structuring of resistance structures

and electrodes directly on shafts for the durable sensor itself. To be self-sufficient newly developed AIN and AIScN based piezoelectric structures have to provide the energy for the sensor module which in turn will be assembled on a cylindrical low temperature co-fired ceramics. This subproject investigates both the suitability and the performance of the measuring system for application in wind turbines.



Figure 1: Research wind energy system of the University of Bremen

References

- [1] Tracht, K.; Goch, G.; Schuh, P.; Sorg, M.; Westerkamp, J. F.: Failure probability prediction based on condition monitoring data of wind energy systems for spare parts supply. CIRP Annals 62(1): pp. 127-130, 2013

Intermittent Wind Loads (InterWiLa)

Carl von Ossietzky Universität Oldenburg
Research Group: Turbulence, Wind Energy
and Stochastics

Matthias Wächter, Joachim Peinke
ForWind – University of Oldenburg,

Partner:
Alexandros Antoniou, Philipp Thomas,
Fraunhofer IWES (Coordinator)

Funding: Federal Ministry for Economic
Affairs and Energy (BMWi)

Ref.Nr. 0325798B

Duration: 01/2015 – 12/2017

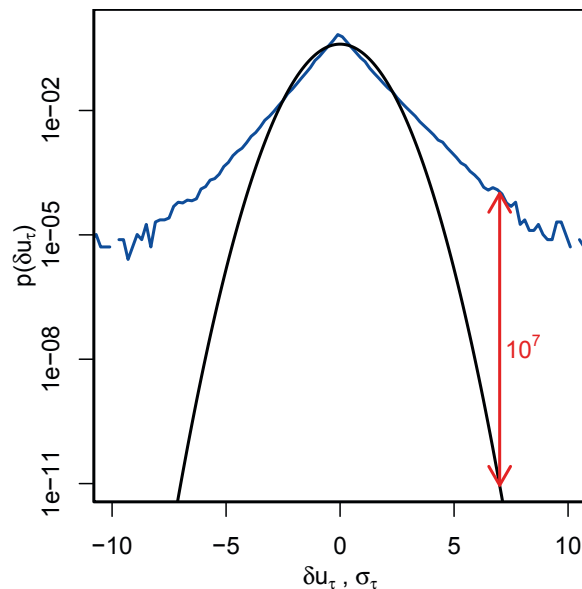

Figure 1: PDF of wind speed increments $\delta u_\tau = u(t+\tau) - u(t)$ for a time lag of $\tau = 3$ s, measured at the FINO 1 platform in the German North Sea (blue line). Additionally a Gaussian PDF is shown with identical mean and standard deviation (black line). The probability of a 7σ event is underestimated by a factor of 107 by the Gaussian assumption.

Introduction

It is well known that real inflow at wind turbines exhibits complex and strongly non-Gaussian statistics, see, e.g., [1]. This observation is commonly called intermittency and holds especially for two-point statistics such as wind speed increments $\delta u_\tau = u(t+\tau) - u(t)$, i.e., wind speed differences over a fixed time lag, see Fig 1. Nevertheless, current industry standards such as IEC 61400 [2] recommend to consider only completely Gaussian wind statistics in the design procedure of wind energy systems.

While a striking difference between this Gaussian assumption and the real-world wind measurements is obvious (cf. Fig. 1), its impact especially on wind turbine loads is still unclear and not understood. The project InterWiLa was designed to tackle this question from a combined numerical and experimental approach. Project partners were Fraunhofer IWES in Bremerhaven (leader) and ForWind – University of Oldenburg.



Figure 2: Test stand for beam samples at Fraunhofer IWES in Bremerhaven. A hydraulic actuator is applying force time series to the right end of the beam.

Project Description

In a numerical approach, damage equivalent loads at different locations were derived from wind turbine simulations using both Gaussian and (more realistic) intermittent wind fields. As an industry level tool, GH Bladed 4.7 was used with the IWES 7.5 MW reference turbine [3]. For further investigations, load time series were extracted from these simulations at different locations in the turbine. From these load time series, damage equivalent loads (DEL) were derived for a first evaluation of the damage related to both types of wind inflow. As a highly loaded location in a wind turbine, a typical rotor blade structure at about 25% of the blade length was selected.

In an experimental approach, those load time series were used to perform experiments on lifetime of typical composite blade material and glued joints. To this end, beams reflecting a typical rotor blade structure were manufactured and tested in a beam test stand at IWES in Bremerhaven. The initiation and development of cracks were observed until total failure of the beams.

Results of the numerical simulations indicate slightly larger DELs for some of the load channels for intermittent wind, compared to Gaussian wind fields as recommended by IEC, see Fig. 2. However, this is not the case for all of the load channels.

Results of the experiments, on the other hand, indicate a stronger damage (in terms of occurrence of the first crack) for loads generated by intermittent wind, if inflow

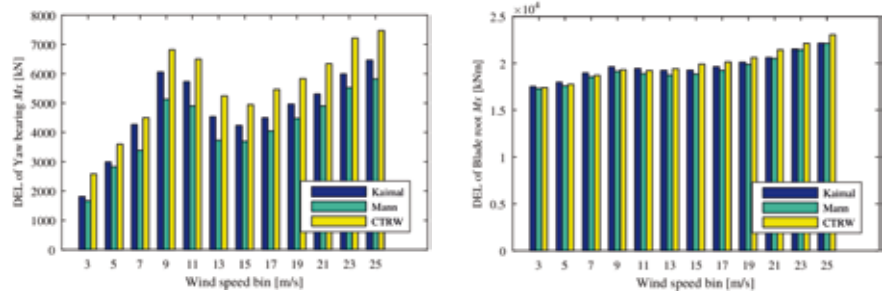

Figure 3: Damage equivalent loads (DEL) as results of the numerical load simulations. Presented are DEL for wind inflow generated by Kaimal and Mann models (using an inherent Gaussian assumption as recommended by IEC [2]) and by the Continuous Time Random Walk (CTRW) model (incorporating realistic temporal intermittency). For the example of the yaw moment (left), the DEL are higher with intermittency, while for the blade root bending moment (right) no significant difference is visible.

wind fields with identical mean and standard deviation are compared, cf. Table 1. The time until total failure shows the reverse behavior, however, in real-world situations, the first cracks are expected to initiate further degradation of the structure, which is not reproduced in the laboratory.

Summary

The project “Intermittent Wind Loads” (InterWiLa) has investigated the impact of wind intermittency on the damage at typical wind turbine composite materials and structures. Numerical simulations did not allow for clear conclusions on whether such impact exists or not. On contrary, in experimental investigations it was found that under intermittent inflow conditions the time until the first damage of beam samples is

significantly reduced. We take this result as a clear hint for the existence of an impact of wind intermittency on damage at wind turbines. More detailed investigations, also on other components besides rotor blades, could be the topic of further projects.

References

[1] Wächter, M.; HeiBelmann, H.; Hölling, M.; Morales, A.; Milan, P.; Mücke, T.; Peinke, J.; Reinke, N., Rinn, P.: The turbulent nature of the atmospheric boundary layer and its impact on the wind energy conversion process, *Journal of Turbulence* 13, 2012
 [2] International Electrotechnical Commission (IEC), International Standard 61400: Wind Turbines, International Electrotechnical Commission, 2005
 [3] Popko W., Thomas P., Sevinc A., Rosemeier M., Bätge M., Braun R., Meng F., Horte D., Balzani C., Bleich O., Daniele E., Stoevesandt B., Wentingmann M., Polman J. D., Leimeister M., Schumann B., Reuter A.: (2018), IWES Wind Turbine IWT-7.5-164 Rev 4, Fraunhofer Institute for Wind Energy Systems IWES, Bremerhaven, <https://doi.org/10.24406/IWES-N-518562>

	Inflow with intermittency				Inflow without intermittency			
	3	5	7	9	4	6	8	10
Beam no.	3	5	7	9	4	6	8	10
T_A [h]	9,0	41,0	1,3	1,5	N/A	96,0	5,3	1,5
T_{total} [h]	45	828	98	188	71	739	122	76

Table 1: Time until occurrence of the first crack (T_A) and time until total failure of the beam samples in the test stand. The inflow wind fields had pairwise identical mean and standard deviation for beams 3 and 4, 5 and 6, 7 and 8, and 9 and 10, respectively.

HyRoS – Multifunctional Hybrid Solution for Rotor Blades Protection

Universität Bremen
Institute for Integrated Product
Development (BIK)

Klaus-Dieter Thoben, Michael Brink,
Jan-Hendrik Ohlendorf

Funding: Federal Ministry for Economic
Affairs and Energy (BMWi)

Ref.Nr. 0325937F

Duration: 12/2015 – 05/2019

Introduction

Rain, hail and frost are damaging the rotor blades of wind turbines. This is particularly evident at the leading edges, the front edges of the rotor blades directed against the wind. Ice can quickly build up there and erosion damage is more frequent. All this considerably reduces the efficiency of a wind turbine. At present, the problem is mostly addressed with special paint systems and coatings. The Institute for Integrated Product Development (BIK) at the University of Bremen and partners in the joint project "Multifunctional hybrid Solution for Rotor Blades Protection" (HyRoS) are focusing on new material combinations in rotor blade production and on integrated de-icing systems.

Project Description

As part of the joint project "HyRoS" a multifunctional protection of rotor blades of wind turbines will be developed on the basis of a hybrid material solution. The functionality includes the protection of the rotor blade surface against erosion as well as an integrated de-icing system. This will be achieved through a new material combination of non crimp fabric and thermoplastic. Hence, an erosion of the rotor blades can be reduced. The new leading edge will also be equipped with a rotor blade heater, which will be operated with an intelligent energy-efficient control system. This is intended to prevent or reduce icing of the rotor blades in critical regions. Ice formation on the blades is a particular threat in winter at inland locations and usually leads to the turbines being shut down. From an economic point of view, these shutdown phases have a particularly negative impact because in winter there are particularly good wind conditions for electricity generation. Tests conducted by a turbine manufacturer in Sweden have shown that a turbine with rotor blade de-icing can generate at least 25 percent more electricity during the winter months than an identical turbine without de-icing.

The work package of the Institute of Integrated Product Development (BIK) encompasses researching and developing the application technology, i.e. the production processes and devices to reliably apply the multifunctional rotor blade guard into the forming tool. We are also responsible for the scientific and methodological implementation and support of the test series. Based on present and future scenarios the joint project will carry out a comprehensive requirements analysis for the technologies, materials, processes and devices to be developed. These scenarios include the production of rotor blades and hybrid rotor blade protection, as well as the operation of the rotor blades. The BIK will use various product development

methods for a systematic and methodical approach. The selection of potentially suitable methods will be based on the requirements analysis. The methods of Design of Experiments will be applied throughout the scientific and methodical development and implementation of the test series. For example, the determination of suitable material parameters and significant factors that have an impact on production processes. These offer a systematic approach to identify relationships of causes and effects and make them quantifiable. The project goal, to relevantly reduce rotor blade erosion, offers a number of advantages. For example, increasing the efficiency of a wind turbine by reducing the air turbulence at the surface of a rotor blade, and the risk of blade damage reduced, even at higher tip speeds envisaged for the future. In addition, the integrated heating system provides new installation areas. A project successful in developing a multifunctional hybrid solution to protect the rotor blades, and proving its ability on a demonstrator, will be a great contribution to an environmentally friendly, reliable and affordable energy supply.

Summary

Wind turbines are exposed to extreme loads and environmental influences. Harmful erosion and weather-induced ice build-up occur especially at the leading edges of the rotor blades. This can lead to considerable aerodynamic performance losses of the turbine. As part of the "HyRoS" joint project, multifunctional protection of rotor blades is being developed on the basis of a hybrid material solution. On the one hand, this should include protection of the nose edge against erosion by a novel material combination of multiaxial fabrics and a thermoplastic, and on the other hand it should prevent ice build-up by an integrated de-icing system.



Figure 1: Damage to wind turbines such as this one at the leading edge of a rotor blade requires extensive servicing and the use of special forces suitable for high altitudes. (Source: MB Bladeservice Einbeck)

Adaptive Operation and Control of Offshore Wind Farms Based on Specific Operational Strategies for Optimized Yield, Loads, and Grid Integration (RAVE – OWP Control)

Carl von Ossietzky Universität Oldenburg
Institute of Physics,
Research Group: Wind Energy Systems
Research Group: Turbulence, Wind Energy
and Stochastics
Research Group: Energy Meteorology

Martin Kühn, Joachim Peinke,
Detlev Heinemann, Andreas Rott,
Vlaho Petrović, Isabelle Prestel,
Gerald Steinfeld, Matthias Wächter,
Pyei Phylo Lin

Partners: Stuttgart University,
Stuttgart Wind Energy (SWE);
Global Tech I Offshore Wind GmbH;
German Lloyd Industrial Services GmbH
(DNV-GL)

Funding: Federal Ministry for Economic
Affairs and Energy

Ref.Nr. BMWi (FKZ 0324131A)

Duration: 03/2017 – 02/2020

Introduction

The expansion of offshore wind energy use is progressing rapidly. By 2015, more than half of the German government's target for 2020, 6.5 GW installed nominal capacity for the offshore sector, has already been achieved. Despite this increasing importance for the power supply, there is still great potential for technical and economic improvement. This is the background to the RAVE project, in which various new simulation and control approaches are to be developed jointly by universities and industrial partners and tested close to industry.

Project Description

The project pursues two main objectives – from a technical-scientific and strategic development point of view – to help operating offshore wind farms more economically.

Technically and scientifically, the planned project aims at the methodical development of different operating strategies for yield, load and grid optimisation in offshore wind farms by regulating the whole wind farm. In addition to a novel, modular control concept for the active power of the individual wind turbines, this is to be achieved by more precise determination of the fatigue loads of the individual wind turbines in the wind farm and their load reserve in relation to the design loads.

The second main objective is of a strategic developmental nature. It lies in the combination of academic research on new control and operation strategies as well as load models with current industrial developments for the design and more economical operation of future large offshore wind farms.

The first main - technical-scientific - research objective is pursued by the four technical work packages (WP) A to D and their sub-packages with the following sub-goals:

- Development of fast industrial wind farm simulations based on a flow-structure coupling (WP A.1) to develop and test control and operation concepts (WP B) and calculations of individual fatigue loads (WP C and D). This requires large-eddy simulations as well as Lidar and load measurements in the *alpha ventus* wind farm as a reference.
- Development of a modular, application-oriented wind farm controller for different operating strategies for yield, load and grid optimization in offshore wind farms (WP B.1).

- Determination and monitoring the fatigue loads to set up a load envelope for design and subsequent operation based on a physical model of the dynamic wake flow (WP C). New methods such as the so-called "Wake Meandering Model" are to be further developed using Lidar and load measurements in the *alpha ventus* wind farm and tested in industrial design practice (WP D.3). This exact determination of the individual loads also forms the basis for the various operating strategies previously to be developed in the second sub-target, which are to use the load reserves of the individual turbines in the wind farm economically.
- The concepts developed jointly by universities and industry are to be tested in WP D using physical wind farm models and in industrial design practice for fatigue loads of future wind turbines on the one hand and tested regarding economic efficiency (WP D.3) on the other, in order to be subsequently transferred to utilisation.

The second high-level project goal with its strategic development approach is to avoid the major delays that have occurred in the past, particularly in the practical, industrial application of new regulatory procedures in wind energy. For this purpose

- tasks are worked on cooperatively and there is an intensive exchange between university and industrially managed sub-tasks (WP A-D),
- the new, risky control approaches for a real wind farm with 80 wind turbines can be validated on the basis of real SCADA data (WP D.1),
- improved calculation methods for fatigue loads are being tested in industrial design practice for future wind turbines (WP D.2)

Use of the *alpha ventus* and *Global Tech I* offshore wind farm data

The many-sided subtasks rely on a data basis that is obtained on the one hand from the *alpha ventus* test field and on the other hand from the *Global Tech I* offshore wind farm, which went into operation in September 2015. Previous RAVE projects have created an extensive database for *alpha ventus* on which to build and expand in this project. The comprehensive sensor measurement system installed on the wind turbines in *alpha ventus* form the basis for some of the concepts being investigated in this project. In addition, the FINO1 measuring station offers the possibility of recording meteorological data required for the validation of measurement data and the calibration of measuring systems. However, the 3x4 turbine layout of the *alpha ventus* wind farm

is not representative of large offshore wind farms. In particular, multiple wakes (overlay of four or more wakes), as they occur in large offshore wind farms, do not occur in *alpha ventus* due to the layout. The data from a wind farm with only 6 turbines accessible for the project is too small to validate the short-term forecast model in WP B.1. For this reason, in addition to the measurements in *alpha ventus*, data from the *Global Tech I* wind farm with the Adwen AD 5-116 turbine type are also collected. With 80 wind turbines, *Global Tech I* offers both good possibilities for the transferability of results from investigations on the largely identical turbines in *alpha ventus* and a suitable reference for large offshore wind farms. However, since only the standard SCADA data is available in *Global Tech I*, this wind farm can be used for comparison

with validated models, but is not suitable for validation as such, as load measurements are missing.

Brief description of the work packages

Fig. 2 illustrates the project structure. Above the block diagram, the two scientific work objectives are mentioned, which mainly relate to work packages B and C. An overview of the four technical work packages is given below. In the short description of the resulting 10 subtasks, the leading project partner is named in each case.

A. Reference data wind farm flow

Work package A includes data collection and the necessary measurement campaigns from *Global Tech I*. Measurements at *alpha ventus* have been cancelled due to the recent incident at AV7. The data serves to



Figure 1: Offshore wind farms *alpha ventus* (top) and *Global Tech I* (bottom)

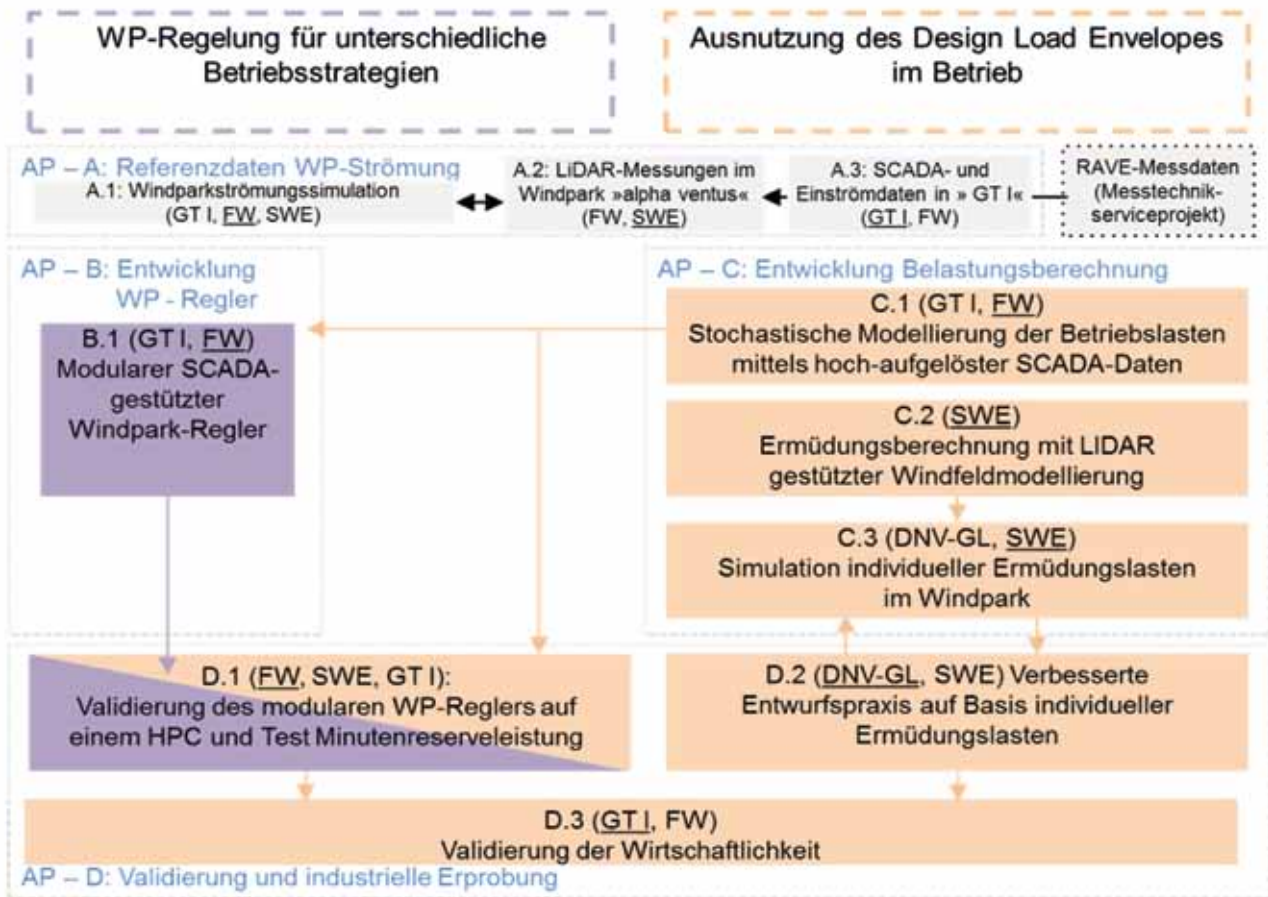

Figure 2: Project structure and higher-level project goals

validate the simulations and is used in all other work packages.

In A.1, SWE, supported by ForWind, provides a reference model environment that is used for aero elastic simulation of less complex wind farm test cases with special external environmental conditions. In addition, this work package develops a resource-saving, fast simulation environment that also provides reliable accuracy and is intended to function as a wind farm test environment in D.1 for testing and verifying the new modular wind farm controller. ForWind uses the coupling of large eddy simulation and aeroelastic model. This Coupling has been developed and validated in other projects as new computational time efficient flow models in order to correctly map the influence of atmospheric stability for specific selected environmen-

tal and wind farm conditions. At the same time, the findings are also used to improve an industrial wind farm model of *Global Tech I* (GT I).

Experimental validation of the above-mentioned simulation environments in A.1, SWE is done using measurements at Senvion turbines in A.2 in the *alpha ventus* test field. These consist of a reduced Lidar measurement campaign compared to the original application, in which the inflow conditions of two wind turbines are measured synchronously; this configuration represents a novelty in *alpha ventus*. In addition, the loads occurring in these systems, which are equipped with additional load sensors, are recorded and synchronized with the Lidar measurements. Results are used to validate the simulation environment in A.1.

In A.3, high-frequency SCADA data are recorded by GT I, supported by ForWind, in the *Global Tech I* wind farm and measurements of the inflow in the rotor centre (spinner) are carried out on four wind turbines. The SCADA data should be processed and made available in a 1 Hz resolution in order to support and validate the models to be developed in B.1 and C.1.

B. Development Wind farm controller

In the sub-package B.1, ForWind is developing a modular wind farm controller based on standard SCADA data to increase yield, reduce load or support grid stability. Using a shortest time forecast model, the data are used to determine the condition of the wind farm in advance over the next few minutes, taking into account various set point specifications. A cost function is used to evaluate the loads, yield and uniformity

of the feed-in and on this basis the set point specifications of the individual system performance can be optimised. The modular wind farm controller is designed to extend the functionality of an existing wind farm controller.

C. Development for calculation of fatigue loads

Work package C deals with both stochastic modelling of operational loads and the analysis of individual fatigue loads in the wind farm.

In C.1, ForWind develops stochastic models for operational loads and analyses them regarding uncertainties, transferability to wind turbines of the same type and dependencies on different environmental conditions. In *alpha ventus*, stochastic models for operational loads are to be derived from available measurement data at the research data base. For verification of these models a generic numerical aero-elastic turbine model shall be used to ensure a reliable procedure.

In *Global Tech 1* this procedure shall be used to derive stochastic load models from available operational data of that wind farm. For verification of these *Global Tech 1* load models again the generic turbine model shall be used. This way no intellectual properties of Adwen are transferred from *alpha ventus* to *Global Tech 1*. This scheme of work is illustrated in fig. 2.

In C.2, SWE uses the Lidar measurements at Senvion turbines to perform time series validation. The aim is to optimize the existing simulation model regarding the representability of high-resolution environmental conditions. This is a prerequisite for the analysis of the individual fatigue loads at Senvion turbines by SWE with the support of DNV-GL in C.3. In this sub-task the fatigue loads are evaluated with different complex simulation environments for different environmental and wake situations. The partial shading is to be integrated into the fatigue load calculation and the load increase is to be analysed as a function of the wake situation.

D. Validation and industrial testing

Finally, the control and operating strategies from WP B and the methods for load calculation from WP C are industrially tested and evaluated.

The qualitative characteristics of the modular WP controller are verified in D.1 by SWE supported by ForWind. SWE uses the wind farm test environment developed in WP A.1. Both test cases for the representative operating states and a test specification for special cases requiring increased simulation effort are created.

D.2 deals with the comparison of fatigue loads between different simulation methods (1. effective turbulence, 2. DWM, 3. wind farm test environment) and with measurement data based on C.3. The evaluation of the fatigue calculation or the quantification of the error in the fatigue calculation using simple tracking models (effective turbulence, DWM) enables an improvement of the industrial design process and is to be included in guidelines and standards for certification. The task is managed by DNV-GL and is significantly supported by SWE. The economic evaluation of the developed strategies and concepts is carried out in D.3 by the wind farm operator GT I with the help of ForWind. In addition to the financial estimation of the long-term use, this also includes in particular the evaluation with regard to the provision of tertiary control power.

Multi-Dimensional Stresses in High Power Electronics of Wind Energy Plants (HiPE-WiND)

Universität Bremen
Institute for Electric Drives, Power
Electronics and Devices (IALB)

Holger Groke, Johannes Adler,
Bernd Orlik, Nando Kaminski,
Christian Zorn

Funding: 6th Energy Research Programme
of the Federal Government (BMWf)

Ref.Nr. 41V7736

Duration: 10/2017 – 09/2020

Introduction

The loss statistics of major German insurers as well as the "ReliaWind"-Study and field studies of the Fraunhofer Institute for Wind Energy Systems (IWES) prove that the frequency converters of wind turbines have high failure rates and are among the most frequently failing components of wind turbines [1,2].

In wind energy, the power electronics is exposed to particularly harsh conditions. It has to sustain wind and net loads as well as environmental stress. Wind loads are low loads, overload or strong alternating loads due to fluctuations in the wind characteristics. Loads from the grid result from over-voltages and current surges due to switching operations, short circuits or lightning strikes. In addition, there are environmental effects such as temperature gradients, high relative humidity, salty atmospheres etc. The critical factor for the service life of the power electronics, however, is the combination of environmental and electrical operating stresses to which the converter systems are exposed.

Project Description

The aim of the HiPE-WiND research project is to investigate high-performance power electronic systems for wind turbines under real environmental and load conditions, to investigate their failure causes and to develop and experimentally verify concepts for optimising their robustness. This requires tailored test-methods exposing entire converter systems to different stresses simultaneously. The purpose of these investigations is to obtain indications of weak points in the system hardware through accelerated aging and to analyse how to achieve an optimisation of the inverter service life by specifically influencing the electrical loads.

The testing of specimen ranging from the power electronic component to the overall inverter system requires a powerful test system that allows for the application of typical electrical loads of a wind turbine, simulated disturbances and system interactions in a reproducible and repeatable manner and as often as desired. Such a complex test facility with the necessary load functions and adaptable in performance and operating voltage is not yet available throughout Europe and is developed, set up and put into operation within the project. It enables for manufacturer-independent research and an appropriate investigation of the power electronics of modern wind turbines.

In order to guarantee reliable and, in particular, application-relevant results, the researchers at HiPE-WiND work closely together with their industrial partners. In addition to the Institute for Electrical Drives, Power Electronics and Devices (IALB) and the Fraunhofer Institute for Wind Energy Systems (IWES), Enercon (Wobben Research and Development GmbH), Breuer Motoren GmbH and wpd windmanager GmbH & Co. KG are in-

involved representing the industry in the joint project.

The participating institutes are closely linked with the wind turbine manufacturers as well as the manufacturers of the frequency converters and components. By cooperating with the institutes as independent bodies, all necessary information and data can be collected, anonymised and evaluated. Furthermore, the databases of wpd and previous studies regarding field data acquisition serve as a basis for the development of application-relevant test sequences and campaigns. In addition to the realistic multimodal load scenarios, a procedure for accelerated testing is conceived in order to achieve suitably shortened test periods compared to the 1:1 replication of field-typical load profiles. Further analyses on component level in conjunction with component simulations support the activities towards increasing the service life of the whole inverter system under extreme conditions.

Summary

In recent years, there has been no significant reduction in the comparatively high failure rate of power electronics in wind turbines. On the contrary, in some cases the failure rate has even increased. As the failure causes have not yet been conclusively investigated, the problems are far from being solved.

The test facilities of the HiPE-WiND project now enable detailed research of the durability of power electronic systems used in state-of-the-art wind turbines. The examination of failure mechanisms under realistic multimodal environmental conditions as well as load conditions promotes the development of technical improvements increasing the robustness of the converter system.

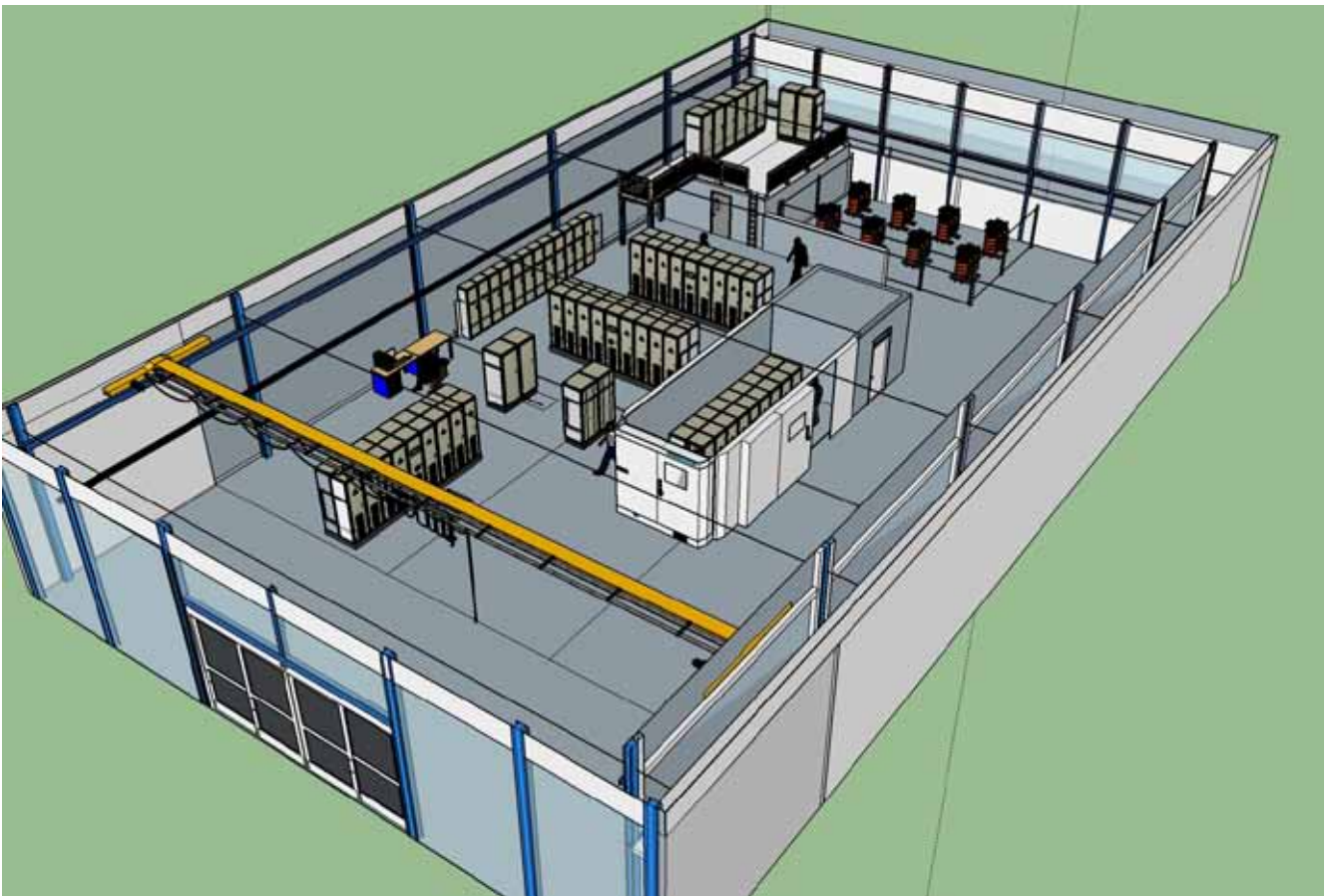

Figure 1 - Schematic representation of the planned test facility

References

- [1] J. B. Gayo, „Final Publishable Summary of Results of Project ReliaWind“, 2011
- [2] A. Bartschat, C. Broer, D. Coronado, K. Fischer, J. Kučka, A. Mertens, R. Meyer, M. Moriße, K. Pelka, B. Tegtmeier, S. Weber und J. Wenske, „Zuverlässige Leistungselektronik für Windenergieanlagen, Abschlussbericht zum Fraunhofer-Innovationscluster Leistungselektronik für regenerative Energieversorgung“, Stuttgart: Fraunhofer-Verlag, 2018

PiB – Predictive Intelligent Operation System to Reduce the Risk of Icing of Wind Turbines

Universität Bremen
Institute for Integrated Product
Development (BIK)

Klaus-Dieter Thoben,
Jan-Hendrik Ohlendorf, Stephan Oelker,
Markus Kreutz, Kamaloddin Varasteh

Funding: Federal Ministry for Economic
Affairs and Energy (BMWi)
Project Management:
Projekträger Jülich (PTJ)

Ref.Nr.: 0324220A

Duration: 12/2017 – 11/2020

Introduction

Wind turbines (WT) and in particular their blades operating in cold climate areas are frequently facing icing problems during winter operation, especially at low temperatures and high humidity. Icing represents a significant threat to the performance and durability of wind turbines [1]. Based on the researches in the project WECO [2] the icing probability of the plants for Northern Germany is between 7 to 14 days and in higher altitudes it can even reach values of up to 30 days per year (see fig. 1). Thus, icing is a relevant factor for the profitability of wind turbines.

Fig. 2 shows a distribution of icing alarm durations created from SCADA-data of different wind turbines acquired in the project. As we see, for some turbines, even single icing alarms can, in fact, last as long as almost a month.

To overcome the icing problem, two approaches exist. While de-icing approach tries to remove the ice after it has been already formed on the blades, the anti-icing approach tries to anticipate the occurrence of the ice and start preventive measures to restrain the formation of the ice. In this regard, the main aim of the research project is to investigate and develop an intelligent management system that is able to forecast and simultaneously deal with ice accretion on rotor blades of wind turbines.



Figure 1: Iced wind turbine, adopted from Project WECO [2]

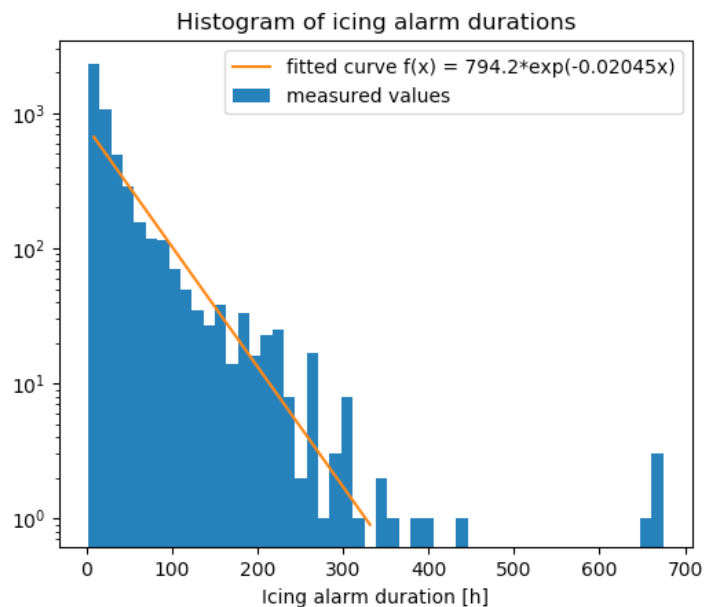

Figure 2: Early result – histogram of icing alarm durations from SCADA-data of several wind farms

Project Description

The project aims to develop a system for predictive and intelligent operation management that will significantly reduce the risk of icing of wind turbines. This system consists of a data-mining component that forecasts the icing events, and a heating system in rotor blades that avoids the formation of icing.

In fact, the approach will be developed based on data mining and data analytics using all data resources including meteorological measurements, SCADA data, life-cycle based, historical and live data. As a part of the project, weather forecasts and data corresponding to installed heating systems in rotor blades will be taken into account. Moreover, the developed system is not restricted to one wind turbine or wind farm only, but also should make a linkage with further wind farms possible. Finally, the various strategies will be developed in order to confront icing before ice formation, which is considered as a particular feature of the project.

The following specific scientific and technical objectives are the goals of the project:

- Increase the availability of a wind turbine by means of an adapted operation management and control of a heating system, even in weather conditions with a high risk of ice formation
- Better planning basis for energy grid operators in Germany through a more accurate forecast of the availability of wind turbine capacity
- Increase the ice prediction accuracy and possible ice formation and thus obtain an increase in energy yield
- Develop a system for predicting the risk of ice formation based on meteorological weather models and plant data
- Transfer of forecasts of ice formation from individual wind turbines to other wind turbines and entire wind farms (networking)
- Develop a comprehensive approach considering heterogeneous data sources such as SCADA data, weather and environmental data (regional and national) and plant data (design, location, history)

- Improvement of energy efficiency by the possibility to heat the parts of a rotor blade differently and only when needed

The project is in its initial phase, where the different types of data have been gathered from the different project partners and are processed and filtered in a common database with a uniform interface. This step also involves analyzing data that is not numeric in nature and thus difficult to handle.

Once the common database is completed, the development of the model will begin using methods from machine learning. The goal is to predict ice few hours before it actually occurs, so that de-icing systems like heating on the rotor blades can activate beforehand in a manner that the icing can be avoided altogether while keeping the de-icing activation time to a required minimum. Additional measures to confirm the validity of the icing prediction in situ are also being developed in parallel.

At a later stage, after the completion of the model development, the integration of the model with de-icing systems on the wind turbines to an intelligent management system will be performed and the functionality of the system will be validated at a test site in a cold region in Germany.

Summary

An intelligent, predictive operation system for reducing and avoiding icing downtimes for wind turbines that shares its knowledge not only across units of the same wind farm, but also across several wind farms, is being developed in this project.

The predictive model will be developed using methods of machine learning. The training data comes from a common database and will include a great variety of data received from project partners, such as historical SCADA-, weather- and plant-data from several wind farm sites.

After developing the model and integrating it with de-icing systems on the wind turbines, a real world validation of the operation system will be performed

References

- [1] Parent, O. ; Ilinca, A. : Anti-icing and de-icing techniques for wind turbines: Critical review. *Cold Regions Science and Technology*, Vol. 65, Issue 1; 2011. pp. 88-96
- [2] Tammelin, B. ; Cavaliere, M. ; Holttinen, H. ; Morgan, C. ; Seifert, H.; Sääntti, K.: *Wind Energy Production in Cold Climate (WECO)*: FMI, ENEL, VTT, GH, DEWI & FMI, 1998

Advanced Wind Energy Systems Operation and Maintenance Expertise (AWESOME)

Carl von Ossietzky Universität Oldenburg,
Institute of Physics
Research Group Wind Energy Systems
Research Group Energy Meteorology

Laura Valdecabres Sanmartin,
Martin Kühn

Funding: EU

Ref.Nr. EU – 642108 (ETN-ITN Projekt,
Marie Skłodowska-Curie Actions)

Duration: 01/2015 - 12/2018

Introduction

The increasing integration of wind energy into the grid, mainly driven by an increase in the installation of offshore farms, together with the aging of existing onshore parks has brought the focus on optimizing the operation and maintenance (O&M) activities, in order to ensure a cost-effective exploitation of wind farms. O&M costs represent, over the lifetime of a wind turbine, an average of 20-25% of the total levelised cost of energy per kWh generated. Besides that, the European wind energy industry is having difficulties in finding skilled professional to define new strategies for O&M activities.

With the aim of designing a training program that faces the main R&D challenges related to O&M and deals with the shortage of highly-skilled professionals on this area, the Advanced Wind Energy Systems Operation and Maintenance Expertise (AWESOME) project was conceived. The AWESOME project (EC-GA contract no 642108) aims at educating eleven young researchers in the field of wind power O&M while building a training network that gathers the whole innovation value chain.

Project Description

One of the eleven young researchers is a PhD student at the research group Wind Energy Systems (WESys) from ForWind – University of Oldenburg. Under the Work Package 3: "Wind Farm O&M Planning" the PhD student aims at developing very-short term wind power forecasts based on remote sensing measurements to improve wind farm operation and the grid stability.

By increasing the accuracy of very short-term wind forecasts (< 30 minutes) the associated costs can be reduced. Reliable forecasts would also benefit wind farm (WF) operators since electricity markets are becoming more flexible with the use of intraday gate closure times as short as five minutes. Very short-term wind power (WP) forecasts are usually based on statistical processing of historical data, so they are unable to detect unexpected WP changes. Long-range lidars (light detection and ranging) and radars are capable of measuring wind speeds and partly direction up to 30 km and present a proper spatio-temporal resolution for WF applications.

The WESys group has an extensive experience on the use of lidars for different wind energy applications such as wake detection and resource assessment. The global aim of the PhD project is to develop an accurate methodology for a very-short term WP forecast in an offshore WF based on remote sensing measurements.

Objectives

The development of an accurate methodology for a very-short term WP forecast in an offshore WF based on remote sensing measurements is based on the achievement of the following four goals:

1. Develop techniques to predict very short-term wind speed with lidar measurements.
2. Develop a methodology to forecast

wind turbine (WT) power based on lidar measurements.

3. Develop a methodology to forecast WF power based on radar measurements.
4. Develop a model to detect and forecast WP ramp events based on radar measurements.

Structure

1. Objective 1: Develop techniques to predict very short-term wind speed with lidar measurements.

In cooperation with DTU, Denmark, the PhD student should develop techniques to forecast wind speeds based on lidar observations in a very short-term horizon of five minutes.

2. Objective 2: Develop a methodology to forecast wind turbine (WT) power based on lidar measurements.

Using large eddy simulations, conducted at the University of Oldenburg, the PhD student should develop techniques to forecast the wind power of an offshore wind turbine in different short-term horizons. The performance of the forecasting technique should be assessed under different meteorological conditions.

3. Develop a methodology to forecast WF power based on radar measurements.

In cooperation with the energy company Ørsted and based on dual-Doppler measurements the PhD student should develop techniques to forecast deterministically and probabilistically the power of offshore wind turbines.

4. Develop a model to detect and forecast WP ramp events based on radar measurements.

The PhD student should focus of detecting and forecasting ramp events based on dual-Doppler radar measurements.

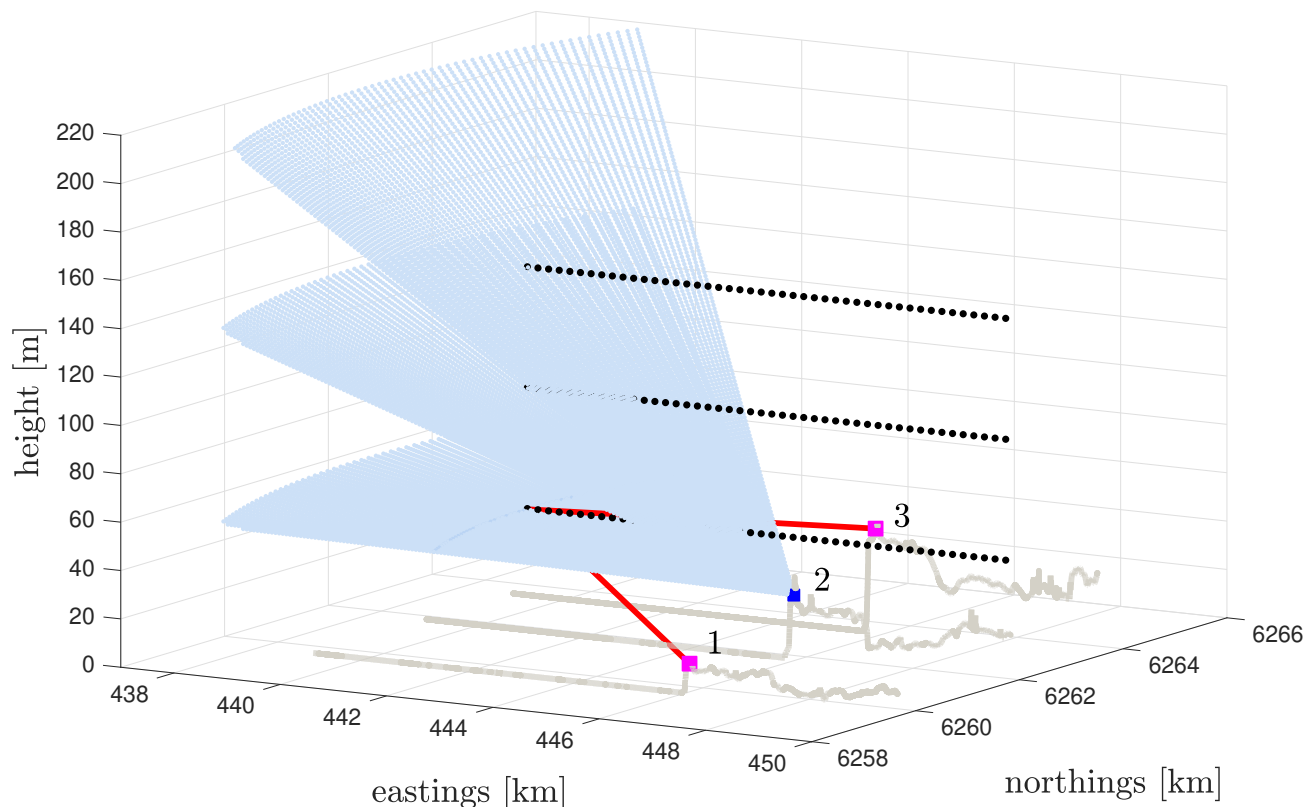

Figure 1: Trajectories conducted with long-range lidars in the RUNE experiment [4]

Summary

Long-range lidar and Doppler radar observations are investigated to develop very short-term forecasts of wind power in offshore wind farms. These include the development of forecasts of wind speed, power of single wind turbines and the aggregation of several wind turbines. Deterministic and probabilistic approaches are investigated. An important focus is put on analysing the forecast of ramp events. The outcome of the research activities is to be published in several journal publications. The research is aimed at reducing the uncertainty of the wind power predictions in minute scale horizons and to contribute to improve the wind farm operation and the grid stability.

References

- [1] Gonzalez, E.; Nanos, E. M.; Seyr, H.; Valdecabres, L.; Yürüşen, N.Y.; Smolka, U.; Muskulus, M.; Melero, J. J.: Key Performance Indicators for Wind Farm Operation and Maintenance, *Energy Procedia*, Volume 137, 2017, pp. 559-570, <https://doi.org/10.1016/j.egypro.2017.10.385>.
- [2] Valdecabres, L.; Friedrichs, W.; von Bremen, L.; M Kühn, M.: Spatial-temporal analysis of coherent offshore wind field structures measured by scanning Doppler-lidar, *Journal of Physics: Conference Series*, 753(072028), doi: 10.1088/1742-6596/753/7/072028 (2016)
- [3] Valdecabres, L.; Steinfeld, G.; Trujillo, J.-J.; L von Bremen, L;

Kühn, M.: Optimizing LIDAR measurements for very short-term power forecasting using a LIDAR simulator, EAWC PhD Seminar, Cranfield, United Kingdom, Poster presentation (2017)

[4] Valdecabres, L.; Peña, A.; Courtney, M.; L von Bremen, L.; Kühn, M.: Very short-term wind speed forecast of coastal flow by dual-Doppler scanning lidar. WESC 2017, DTU, Copenhagen, Denmark. Oral presentation.

[5] Valdecabres, L.; Friedrichs, W.; von Bremen, L.; Kühn, M.: Analysis of Wind Field Fluctuations on Wind Farm Power Output, 12th EAWC PhD Seminar on Wind Energy in Europe. Oral presentation. (2016)

Resilience of Socio-Technical Systems exemplified at the Electricity Transport and Actor System

Carl von Ossietzky Universität Oldenburg
Institute of Physics
Research Group: Turbulence, Wind Energy
and Stochastics (TWiSt)

Hauke Hähne, Matthias Wächter,
Joachim Peinke

Partners:
Ulrike Feudel (Coordinator, Institute for
Chemistry and Biology of the Marine
Environment)
Klaus Eisenack, Thorsten Raabe
(Department of Economics)

Funding: Ministry for Science and Culture
of the Federal State of Lower Saxony

Ref.Nr. ZN3045

Duration: 04/2015 – 08/2019

wind power or photovoltaics are fluctuating and difficult to predict. With an increasing share of renewables, it is a challenge to sustain a reliable energy supply system.

Project Description

The resilience of the electricity transport and actor system as an example of a socio-technical system was investigated, based on preliminary work in the fields of power grids, non-linear dynamics, and turbulence [1-5]. Here we showed evidence that wind power feed-in impacts the short-time fluctuations of the grid frequency in a measurable way. To this end a measurement setup was developed which recorded high-frequency time series of the frequency in the public electricity grid. Such measurements were taken from November 2016 to March 2017, and allowed for a derivation of the grid frequency in 5 Hz temporal resolution. Detailed information is available in ref. [6].

These measurements were compared to freely available power feed-in data provided by ENTSO-E. As a result we see that in times of large wind power feed-in especially many extreme grid frequency fluctuations are recorded, see fig. 1.

Next, we pinpoint the impact of wind power injection on the grid frequency by the analysis of conditioned increment PDFs $p(\Delta_t f | P_w)$. Thus, we learn how likely a frequency increment $\Delta_t f$ is if an amount P_w of wind energy is fed to the grid. We show this PDF for a short ($\tau = 200\text{ms}$) and a long ($\tau = 10\text{s}$) time scale for different ranges of P_w in figs. 2(a) and (b). First, we observe that on the short scale, that the tails deviate from the normal distribution (gray reference curve), whereas the increment PDF is very close to normal on the long scale. Second, for the long time scale, the PDFs are almost identical, irrespectively of P_w . On the short time scale, however, we observe a broadening of the distribution

Introduction

Socio-technical systems provide essential services for society. Important examples are supply systems (like urban water supply, agriculture and forestry, electricity systems) or critical infrastructure (like telecommunications, harbors, and transport systems). Many socio-technical systems currently undergo major transitions or are under pressure from global environmental or demographic change. It is thus of utmost importance to understand how, under changing conditions, such systems can be socially managed in order to remain resilient to disruptions.

As an example of a socio-technical system we study electricity transport and actor systems. This system is of crucial interest for the German Energiewende, where an increasing share of renewable energy supply is fed in. In contrast to conventional energy supply, important renewable energies like

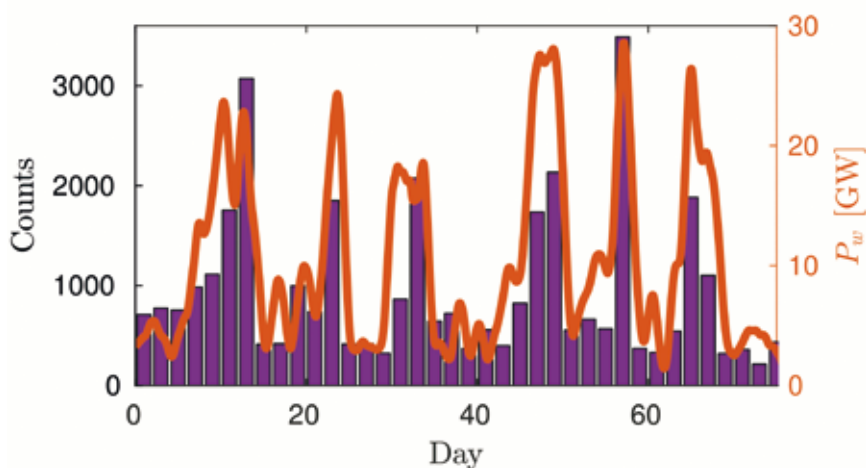

Figure 1: Large short-term increments accumulate on days with a high share of wind power fed to the grid. Left axis and violet boxes: histogram of occurrences of large increments $|\Delta_t f| > 2 \text{ mHz}$ ($\tau = 200 \text{ ms}$) binned for two days for the first 70 days of our measurement. Right axis and orange curve: amount of onshore wind power fed to the grid in Germany. Production data are taken from [11] and smoothed with moving average of two days.

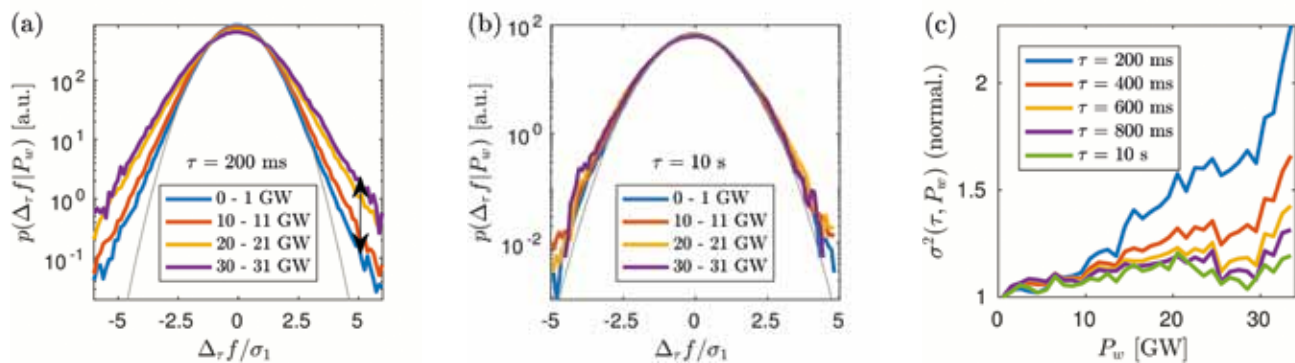

Figure 2: Wind energy feed-in affects the short-term statistics of the power grid frequency. (a) PDF of increments $\Delta_t f$ on the time scale $\tau = 200$ ms for different intervals of P_w (color-coded) normalized by the standard deviation σ_1 of the smallest P_w interval. Increasing feed-in P_w broadens the increment distribution resulting in a tenfold higher probability for a 5σ event (black arrow). (b) Increment PDF for a larger time scale, $\tau = 10$ s. The increments follow the same, almost Gaussian, distribution; independent of the amount of wind energy P_w fed to the grid. (c) Variances of increment distributions plotted against P_w for different time scales (color-coded). On the shortest time scale, $\tau = 200$ ms, the distribution becomes broader with increasing P_w . This effect diminishes with increasing time lags τ .

with increasing P_w . A statistical measure of the amplitude of frequency fluctuations is the variance of these increment PDFs. In fig. 2(c), we show that the variance of the increment PDF increases with P_w for the smallest time lag $\tau = 200$ ms. For increasing time lags τ , this effect quickly diminishes. On time scales of $\tau = 800$ ms and above, the variances show no clear trend with P_w .

Summary

We have shown that wind power feed-in impacts the power grid frequency on time scales that lie below one second. The time range up to approximately one second is interesting because it lies in the range of activation of primary frequency control [7]. This suggests that fluctuations by wind power injection on longer time scales are successfully compensated. Power quality is a key challenge for the grid integration of renewable generators [9]. Although the absolute size of the fluctuations we consider is small ($\Delta_t f < 20$ mHz for $\tau = 200$ ms), a precise knowledge of the fluctuation statistics is essential to correctly estimate the probability of large, possibly critical, increments. In future power grids with a high share of renewable energy sources, the amount of ro-

tational inertia will be much lower than today. This will lead to even faster frequency dynamics with larger amplitudes. If grid de-

sign and control strategies are not properly adapted, such frequency fluctuations may become highly critical for the grid stability [10].

References

- [1] Giovanni, F.; Hejde Nielsen, A.; Falsig Pedersen, N.: Analysis of a power grid using a Kuramoto-like model. The European Physical Journal B 61.4 pp. 485-491 (2008)
- [2] Schmietendorf, K. et al. Self-organized synchronization and voltage stability in networks of synchronous machines. The European Physical Journal Special Topics 223.12, pp. 2577-2592 (2014)
- [3] Milan, P.; Wächter, M.; Peinke, J.: Turbulent character of wind energy. Physical review letters 110.13, p. 138701 (2013)
- [4] Mehrnaz, A. et al.: Short term fluctuations of wind and solar power systems. New Journal of Physics 18.6, p. 063027 (2016)
- [5] Schmietendorf, K.; Peinke, J.; Kamps, O.: The impact of turbulent renewable energy production on power grid stability and quality. The European Physical Journal B 90.11 (2017) p. 222.
- [6] Haehne, H.; Schottler, J.; Wächter, M.; Peinke, J.; Kamps, O.: The footprint of atmospheric turbulence in power grid frequency measurements. EPL (Europhysics Letters), 12, p. 30001 (2018)
- [7] ENTSO-E Operation Handbook Policy 1, [https://www.entsoe.eu/fileadmin/user_upload/library/publications/entsoe/Operation Handbook/ Policy 1 .final.pdf](https://www.entsoe.eu/fileadmin/user_upload/library/publications/entsoe/Operation%20Handbook/Policy%201%20final.pdf)
- [8] Zhang X.-P.; Rehtanz C.; Pal B.: Flexible AC Transmission Systems: Modelling and Control, Springer Science & Business Media (2012)
- [9] Liang X.: IEEE Trans. Ind. Appl. 53 p. 855 (2017)
- [10] Schäfer, B.; Matthiae, M.; Zhang, X.; Rohden, M.; Timme, M.; Witthaut D.: Phys. Rev. E 95: 060203 (2017)
- [11] ENTSO-E Transparency Platform, <https://transparency.entsoe.eu/>

Influence of Short-time Dynamics of Renewable Energies on the Stability of Power Grids

Carl von Ossietzky Universität Oldenburg
Research Group: Turbulence, Wind Energy
and Stochastics (TWiSt)

Katrin Schmietendorf, Matthias Wächter,
Joachim Peinke

Partner:
Universität Osnabrück, Department of
Physics, Prof. Dr. Philipp Maaß

Funding: Deutsche Forschungsgemein-
schaft (DFG)

Ref.Nr. PE 478116-1

Duration: 08/2015 – 07/2018

Introduction

Feed-in fluctuations induced by renewables are one of the key challenges to the stability and quality of electrical power grids. In particular short-term fluctuations disturb the system on a time scale on which load balancing does not operate. Wind and solar power are known to be strongly non-Gaussian with intermittent increment statistics in these time scales. We investigate the impact of short-term wind fluctuations on the basis of a Kuramoto-like power grid model considering stability in terms of desynchronization. Details of these investigations are found in [1]. We present a procedure to generate realistic feed-in fluctuations with temporal correlations, Kolmogorov power spectrum and intermittent increments. By comparison to correlated Gaussian noise of the same spectrum and Gaussian white noise, we found out that correlations are essential to capture the likelihood of severe outages.

Project Description

To capture the main characteristics of real wind feed-in, we generate intermittent time series on the basis of a Langevin-type model and impose a realistic power spectrum. For comparison, we use correlated Gaussian noise of the same spectrum and Gaussian white noise. The stochastic feed-in is implemented into a Kuramoto (KM)-like power grid model, capturing frequency and voltage dynamics in the order of seconds. The KM approach is based on electrical engineering standards [2] and has also been used in nonlinear dynamics and control theory. With this study, we investigate the impact of stochastic feed-in with realistic properties (temporal correlation, realistic power spectrum and intermittent increment statistics). We clarify which characteristics have to be taken into account for the likelihood of noise-induced desynchronization given by the average escape time.

The Dynamical Model

In power system dynamics, a synchronized state with constant frequencies, voltages and stationary power transfer is the desired mode of operation. Within the KM-like approach, the power grid is represented by a

network of N synchronous generators and motors transforming mechanical power into electrical power, or vice versa. The coupled dynamics of the phase angles δ_i and magnitudes E_i of the complex nodal voltages are given by

$$\begin{aligned}\ddot{\delta}_i &= -\gamma_i \dot{\delta}_i + P_{m,i} - \sum_{j=1}^N B_{ij} E_i E_j \sin \delta_{ij}, \\ \alpha_i \dot{E}_i &= C_i - E_i + \chi_i \sum_{j=1}^N B_{ij} E_j \cos \delta_{ij},\end{aligned}$$

Network topology

We first consider a two-machine (G-M) system as the basic component of any power network, Fig. 1(a). Secondly, the complex network topology is based on an IEEE test system with 33 generators, 40 consumers and 108 links, Fig. 1(b). The machine parameters are set equal to $\gamma_i = 0.2$, $\alpha_i = 2.0$, $C_i = 0.993$, $\chi_i = 0.1$. $P_{m,i}$ and B_{ij} are specified below.

Implementing noise

The increment probability density functions (PDFs) of measured wind power data significantly deviate from Gaussianity and its power spectrum $S(f)$ displays 3/5-decay with some discrepancy in the high frequency range (see Fig. 2).

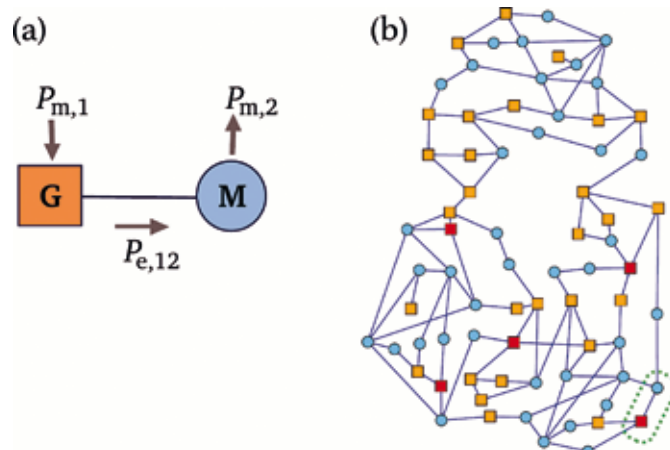

Figure 1: (a) Two-machine system: generator G with input $P_{m,1}$ transferring electrical power $P_{e,12}$ to a motor M with output $P_{m,2}$. (b) IEEE topology: orange/red squares denote generators, blue circles motors.

Based on this, we consider three types of synthetic feed-in noise. For the most realistic scenario, we generate intermittent power time series by use of the Langevin-type model

$$\begin{aligned} \dot{y} &= -\gamma y + \Gamma(t), \\ \dot{x} &= x \left(g - \frac{x}{x_0} \right) + \sqrt{Dx^2}y. \end{aligned}$$

Secondly, we drop the intermittency feature and use Gaussian noise of the same power spectrum and standard deviation. By enforcing the spectrum we induce temporal correlations. This type of noise is referred as Gaussian53 in the following. Thirdly, we put aside the applicational requirements and consider plain Gaussian white noise.

System outages due to desynchronization in the two grid topologies

We define the first-escape time T_{out} as the time at which the first machine desynchronizes. Fig. 2 and 3 show examples of desynchronization scenarios for both grid topologies. For the spatial correlations of the noise we restrict ourselves to the two limiting cases, namely independent power feed-in $\tilde{P}_i(t)$ and global noise $\tilde{P}(t) = \tilde{P}(t)$.

For the two-machine system, we observe in fig. 2(a) that at \bar{T}_{out} the system leaves its basin of attraction and enters the limit cycle region. Obviously, escaping is not simply a matter of the actual magnitude of the feed-in noise, but essentially depends on the system’s location in phase space. Fig. 2(b) shows average escape time \bar{T}_{out} as a function of intermittence strength D and for Gaussian53 noise for different penetrations p . The higher the percentage of fluctuating input and the intermittency strength D , the lower the system stability with respect to noise-induced desynchronization. Results for the IEEE grid in fig. 3 follow similar trends. However, the differences between strongly intermittent and Gaussian53 noise, as observed in the two-machine system, are not apparent here.

Summary

We implemented intermittent realistic feed-in fluctuations with temporal correlations,

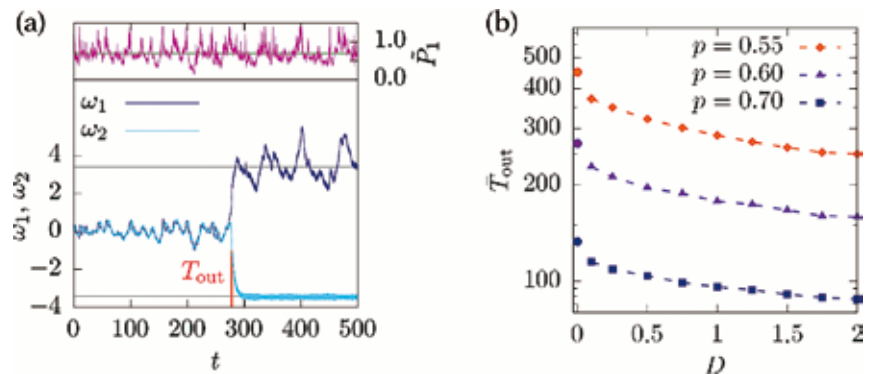

Figure 2: Escape scenario in the two-machine system. (a) Generator input $\tilde{P}_1(t) = P_{m,1} + px(t)$ ($D = 2.0$ and $p = 0.7$), generator frequency ω_1 , and motor frequency ω_2 , the gray lines indicate the location of the stable limit cycle. Escape at $T_{out} = 283$. (b) \bar{T}_{out} as a function of D for $p = 0.55, 0.6$, and 0.7 , calculated from $M = 10\,000$ trajectories. Circles denote \bar{T}_{out} for Gaussian53 noise.

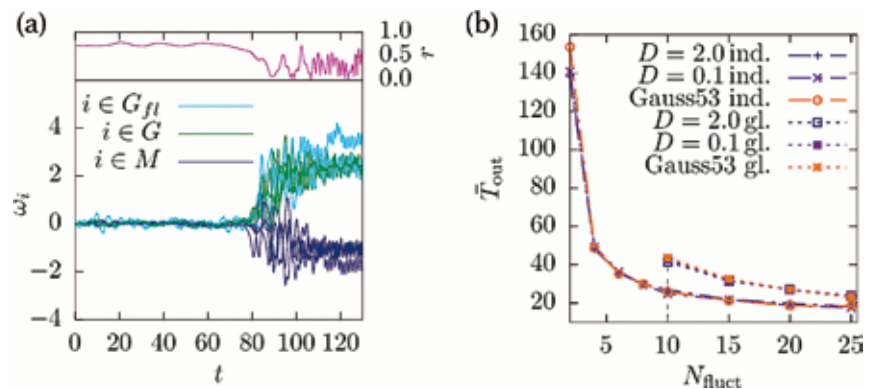

Figure 3: Escape scenario in the IEEE grid: (a) Phase coherence r and frequencies ω_i for the first twelve machines, that fall out. Line colors indicate the machine type. (b) \bar{T}_{out} as a function of N_{fluct} . Strongly intermittent ($D = 2.0$), weakly intermittent ($D = 0.1$) and Gaussian53 noise, each individual and global, calculated from $M = 25\,000$ trajectories. For global noise and $N_{fluct} < 10$ stable configurations occur, which survive simulation intervals of $T > 30\,000$.

realistic power spectrum and intermittent increments into a KM-like power grid. By comparison to Gaussian correlated noise and Gaussian white noise we identified which feed-in characteristics have to be taken into account for investigations on power grid stability. In a complex transmission grid with a single node, e.g. representing a large offshore wind farm, severe outages may happen in form of noise-induced desynchronization. These are mainly due to correlation of the feed-in and the intermittency feature by itself plays a minor role. In summary, we showed that the characteristics of real wind power potentially destabilize the power grid. Subsequent studies

on power systems with fluctuating feed-in should address spatial correlations, optimal embedding, smart storage and control.

References

[1] Schmietendorf, K.; Peinke, J.; Kamps, O.: The impact of turbulent renewable energy production on power grid stability and quality, Eur. Phys. J. B 90: 222 (2017), DOI: 10.1140/epj/b/e2017-80352-8
 [2] Kundur, P.; Balu, N.J.; Lauby, M.G.: Power system stability and control, McGraw-Hill (1994)

GEOVISOL – Effects of the Geographical Distribution and Temporal Correlation of Wind and Solar Input on the Power Supply System

Universität Bremen
Bremen Institute for Metrology,
Automation and Quality Science (BIMAQ)

Volker Renken, Michael Sorg

Funding: Federal Ministry for Economic
Affairs and Energy (BMWi)

Ref.Nr. ID: 0325695B

Duration: 09/2015 – 06/2017

Project Description

The rising penetration of renewable energies became an important issue in the German electricity sector within the past years. For some regions the renewable generation is already surpassing the power demand. Because of the geographically and temporal varying distribution of the generation of renewable energy, a geographical distribution of the energy is inevitable. In order to plan the required infrastructure for the energy distribution, a detailed knowledge about the geographical and temporal power generation is crucial. However, the data availability for the distribution of the renewable power generation in Germany is insufficient due to the complexity of the energy system there are only simulation based studies available.

For this reason, a real measuring data based comparison between the renewable power generation and the electricity demand is conducted within GEOVISOL [1]. The data is given as time series of 15 minutes average values for each zip code region for wind, solar and demand quantities. For enhancing the still incomplete data, model-

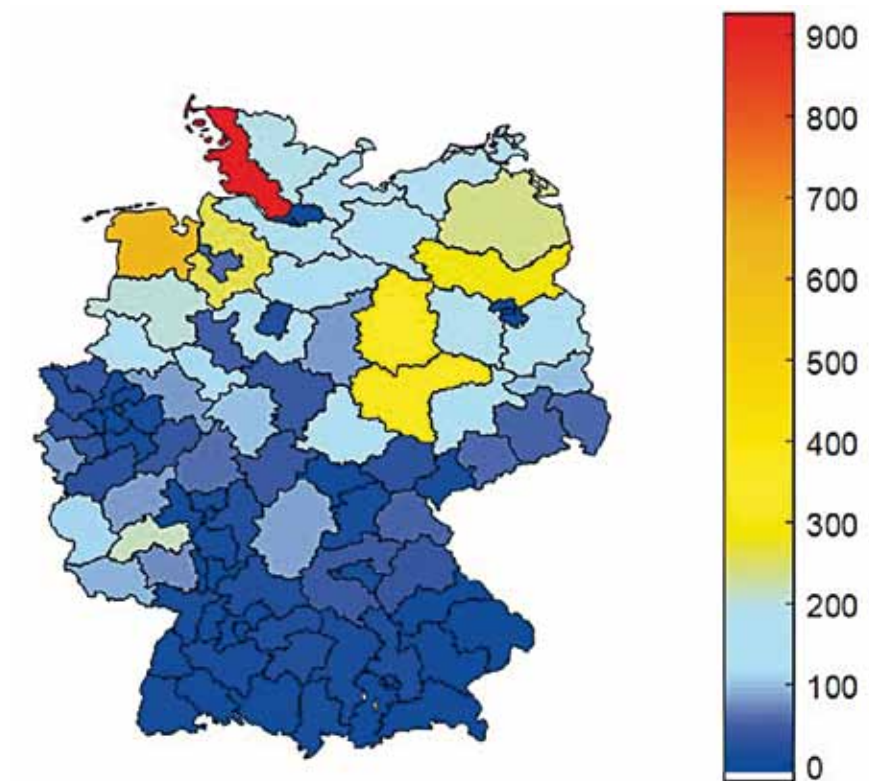

Figure 1: Mean wind energy generation in MW 2014 of 95 zip code regions

based data filling algorithms are introduced and compared to conventional interpolation techniques [2]. As a result, the data filling algorithms are validated and the power generation is shown to be very heterogeneous over space and time. Due to the generated measurement based data set, infrastructure questions regarding the energy system can be answered with higher reliability.

References

- [1] V. Renken: Auswirkung der geographischen Verteilung und zeitlichen Korrelation von Wind- und solarer Einspeisung auf die Stromversorgung (GEOVISOL). Konferenz „Zukunftsfähige Stromnetze“, Berlin, Sep. 22-23, 2016, (oral presentation)
- [2] V. Renken, M. Sorg, A. Fischer: Regionale Bewertung der Einspeisung erneuerbarer Energien auf Basis von Messdaten und einer modellbasierten Datenergänzung. DFMR Windenergetagung, Bremen, March 16, 2017, (oral presentation)

IR-Vortex – Infrared Thermography as a Measurement Technique for Visualization of Vortex Structures on rotating Rotor Blades

Carl von Ossietzky Universität Oldenburg
Institute of Physics,
Research Group: Turbulence, Wind Energy
and Stochastics (TWiSt)

Gerd Gülker, Dominik Traphan,
Ivan Herráez, Sebastian Ehrich,
Joachim Peinke

Partners: Fraunhofer Wilhelm-Klauditz-
Institute for Wood Research (WKI)
Braunschweig;
O. Lutz, Authorized Expert on Fibre
Composite Materials, Bundorf;
KENSYS GmbH Münster;
RENERCO Renewable Energy Concepts
AG München.

Funding: Federal Ministry for the Environ-
ment, Nature Conservation, Building and
Nuclear Safety (BMU)

Ref.Nr. 0325401A

Duration: 11/2011 – 06/2015

Introduction

Due to increasing number of wind energy converters (WEC) new efficient monitoring and diagnostic methods are required, which can identify damages and failures remotely during continuous-running operation. This is particularly important in offshore wind parks. Modern rotor blades represent highly loaded parts of WEC worsened by progressive lightweight design and increasing length. Thus, defects within the glass or carbon fibre reinforced plastic as well as uncontrolled boundary layer transition have to be avoided. Consequently, quality control and regular on-site testing of rotor blades is essential for the economic operation. So far,

testing is done often visually or manually in a quite time-consuming way. Recently, non-destructive testing methods have gained increasing attention. Especially infrared thermography (IRT) is a very promising candidate.

Project Description

The main goal of this joint project, which is carried out in cooperation with the partners Fraunhofer Wilhelm-Klauditz-Institute for Wood Research (WKI), O. Lutz Authorized Expert on Fibre Composite Materials, KENSYS GmbH and RENERCO Renewable Energy Concepts AG, is to investigate the recorded signatures within thermograms and to relate these patterns to the associated flow situation and to identify the potential for damage recognition and unfavored operational conditions.

To demonstrate the capabilities of IRT a typical thermogram of a real rotor blade in operation is shown in Fig. 1. The thermal signature clearly shows two main details, which are related to above mentioned problems. In the lower part turbulent wedges generated probably by surface defects located near to the leading edge of the airfoil can be recognized. These turbulent regions appear colder as the rotor blade is warmer than the surrounding air, which is often the case in the early morning sun. Further on, a clear line is visible which separates a warmer from a colder part of the airfoil and identifies the natural laminar-turbulent transition of the boundary layer.

To determine, which temperature signature represents which flow situation, combined measurements with IRT and high speed particle image velocimetry (PIV) are car-

ried out on a flat plate and on an airfoil model with artificial defects, here obstacles of different sizes. These measurements are performed in the wind tunnel to be able to generate different wind speeds and Reynolds numbers. As a main result of the PIV measurements different flow regimes could be identified describing the effects depending on the defect-height related Re-number Re_h [1]. It shows, that below a certain critical value of Re_h the turbulent wedges are mainly localized without spreading and without destabilizing the boundary layer. The situation changes above the critical value of Re_h , leading to a spreading of the wake and to a detached boundary layer, which may be unwanted and can lead to undesired loads and losses.

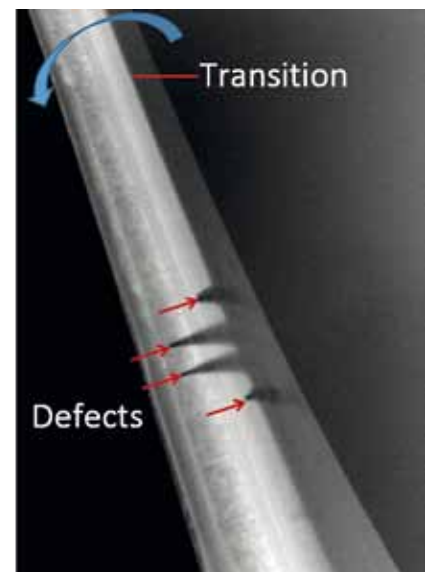

Figure 1: Thermogram of a rotating rotor blade show turbulent wedges due to defects and the transition line in darker colors

Contrary to IRT measurements with PIV at operating WEC are difficult. Thus, the measurements simultaneously performed with IRT and PIV in the wind tunnel are compared to find out if both methods yield the same information about the flow situation within the boundary layer. In Fig. 2 results of both methods obtained in a turbulent wedge behind an obstacle of height $h=1.75\text{mm}$ are shown color-coded at $Re_h=1150$.

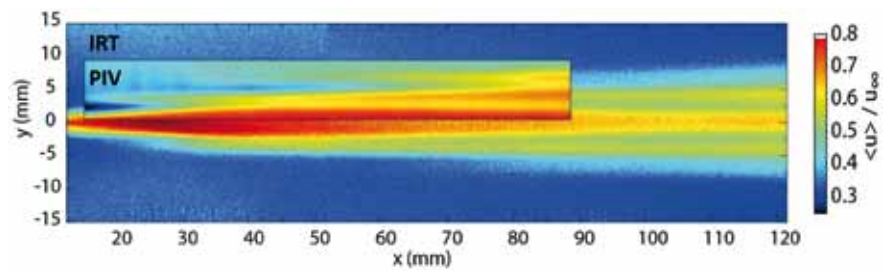

Figure 2: Comparison of PIV (foreground) and IRT (background, false colours) measurements of a turbulent wedge on a flat plate show very good agreement

In the background the thermogram is shown overlaid by an excerpt of the corresponding velocity field measured by PIV. The temperature is depicted color coded in arbitrary units to match the color range of the velocity field for easier comparison. Both measurements show very good agreement. This implies that any particular flow phenomenon near the surface can be potentially mapped in a thermogram.

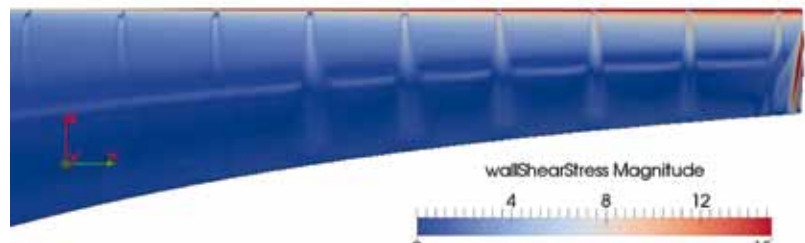

Figure 3: Wall shear stress from RANS simulation of a rotor blade with 10 turbulators

To get an indication of the impact of the artificial defects on the airfoil performance, lift force measurements were also conducted on an DU 91-W2-250 profile without and with five obstacles of diameter $d=2\text{mm}$ each and for different angles of attack (AoA). Surprisingly we found, that these tiny modifications already lead to a decrease in lift force at maximum region, which corresponds to an AoA of 10° , of about 5%. In addition, particularly in the post stall range the fluctuations of lift forces increase pronounced by more than 50%, which lead to higher dynamic loads and may influence the predicted lifetime of the rotor blades.

Finally, for a better insight in the underlying basic consequences of rotor blade damages and for validation a RANS simulation of a complete WEC with DU 91-W2-180 airfoils was accomplished using a $k\text{-}\kappa\text{-}\omega$ transition model. In fig. 3 the result of the simulation for the outer half of an airfoil equipped with 10 surface defects in total is shown.

In fig. 3 the wall shear stress on the surface of an airfoil is shown which according to the Reynolds Analogy [2] is known to be closely connected to the temperature signature of a thermogram. A comparison with fig. 1 and with the experimental results obtained dur-

ing our wind tunnel measurements exhibits that the simulation predicts very similar temperature structures representing turbulent wedges behind obstacles within the boundary layer. Moreover, it indicates the bigger influence of the outer disturbances compared to the inner ones. In conformity with the findings in the lab experiments this can immediately be explained by an increase of the velocity in a rotating system from the root to the tip, which leads to an increasing Re_h . Hence, outer obstacles are already above the critical Re_h , while the inner ones are below that value.

Summary

The results of the present study show that IRT is a well suited method for rotor blade inspection. Combined measurements of IRT and PIV have proven, that details of the flow structure within the boundary layer e.g. turbulent wakes of small defects or laminar-

turbulent transition can be identified from the temperature signature recorded by an easy to use thermographic camera. CFD simulations of a whole WEC model with artificial defects on the rotating rotor blades show nearly the same structures as the thermograms and can thus be used to get a better understanding of the underlying principles.

References

- [1] Traphan, D. et al.: High-speed measurements of different laminar-turbulent transition phenomena on rotor blades by means of infrared thermography and stereoscopic PIV, Proc. 10th Pacific Symp. on Flow Visual. and Image Proc., Naples, 2015
- [2] Kakac, S. and Yener, Y.: Convective Heat Transfer, Second Edition, CRC Press, 2nd edn. (1994)

SHM_Rotorblatt: System for Early Damage and Ice Detection for Rotor Blades of Offshore Wind Turbines

Leibniz Universität Hannover
Institute of Structural Analysis,
Institute for Information Processing

Stavroula Tsiapoki, Thomas Krause,
Stephan Preihs

Funding: Federal Ministry for the Environ-
ment, Nature Conservation, Building and
Nuclear Safety (BMU)

Ref.Nr. 0325388

Duration: 12/2011 – 06/2016

Introduction

The rotor blades of a wind turbine form a vital part of the overall structure and their continuous monitoring is therefore of great significance. The production of rotor blades is still mostly performed manually and leads to a varying quality. Defects due to fabrication, fatigue and extreme loads are the main reasons for the beginning and propagation of damage. Among the most often encountered damages are bondline failure between the upper and lower shell of the blade and delamination of the composite material. Both damage types can influence the load bearing behavior of the rotor blade and potentially disturb the operation of the wind turbine.

The annual failure rate of rotor blades is relatively low compared to other components of the turbine, such as the electrical system, but an occurrence of damage on the rotor blades causes a longer period of downtime that can reach up to 5 days [1]. The standstill of the wind turbine results in great costs, which are even higher in the case of offshore wind turbines. Therefore, the rotor blades should be continuously monitored and structural health monitoring methods

have to be developed, in order to detect damage at an early stage and prevent the total loss of the blade structure.

Structural health monitoring contributes to early damage detection and to the improvement of competitiveness by preventing high maintenance and repair costs. Despite the existence of various monitoring systems, the visual inspections are still necessary, since the existing systems have not reached a satisfying level of reliability.

Project Description

Within the preceding project „Adaption and application of an early damage detection and load monitoring system for composite rotor blades of wind turbines“ (FKZ 0327644B) a method based on the proportionality of the velocity in the position of maximum displacement and maximum dynamic stress was developed [2].

In this project, a vibration-based SHM-scheme (see Fig. 1) and an acoustic emission (AE) approach based on airborne sound were developed and tested for damage detection at wind turbine rotor blades. Mechanical and acoustic data were gained both under test facility conditions and at operating state. For this purpose a fatigue test on a 34 m rotor blade (see Fig. 2) as well as measurements on a 50.8 m blade of a wind turbine in operation were conducted. The fatigue test included an eigenfrequency test, an ice-accretion detection test, as well as a fatigue test in the edgewise direction until the development and propagation of damage. During the measurements in operation the mechanical and the acoustic system will be installed in a 3.4 MW wind turbine, in order to obtain data that correspond to the real operating conditions. The vibration-based approach includes the estimation of condition parameters (CPs), machine learning by means of data clas-

sification for changing environmental and operational conditions (EOCs) and hypothesis testing by using the acceleration signals of six measurement positions that are distributed over the blade length. A residue from the stochastic subspace identification (SSI) method and a residue from a vector autoregressive (VAR) model were used, in order to obtain two CPs. These are used as indicators for changes in the response of the structure. The airborne sound acoustic mission damage detection approach monitors the blade with three fiber optical microphones. A model of the cracking sound was developed, which describes characteristics of these sounds in the time-frequency-power domain. A detection algorithm uses these characteristics to detect damages, to estimate their significance and to handle environmental noise. Both methods were applied on data from a fatigue test of a 34 m rotor blade, which was harmonically excited for over one million load cycles in edgewise direction, leading to a significant damage at the trailing edge.

Further, the potential of combining the two complementary approaches could be shown.

Summary

The results of a SHM concept that consists of the three steps of machine learning, the calculation of CPs and hypothesis testing were compared to the results of an airborne sound damage detection algorithm for the fatigue test of a 34 m rotor blade. Four blade states were documented during the fatigue test: undamaged state, existence of fatigue, occurrence of a significant failure at the trailing edge and damage propagation.

For the SHM scheme, two CPs resulting from the SSI method and VAR models were presented for different settings, such as two types of classification, confidence intervals

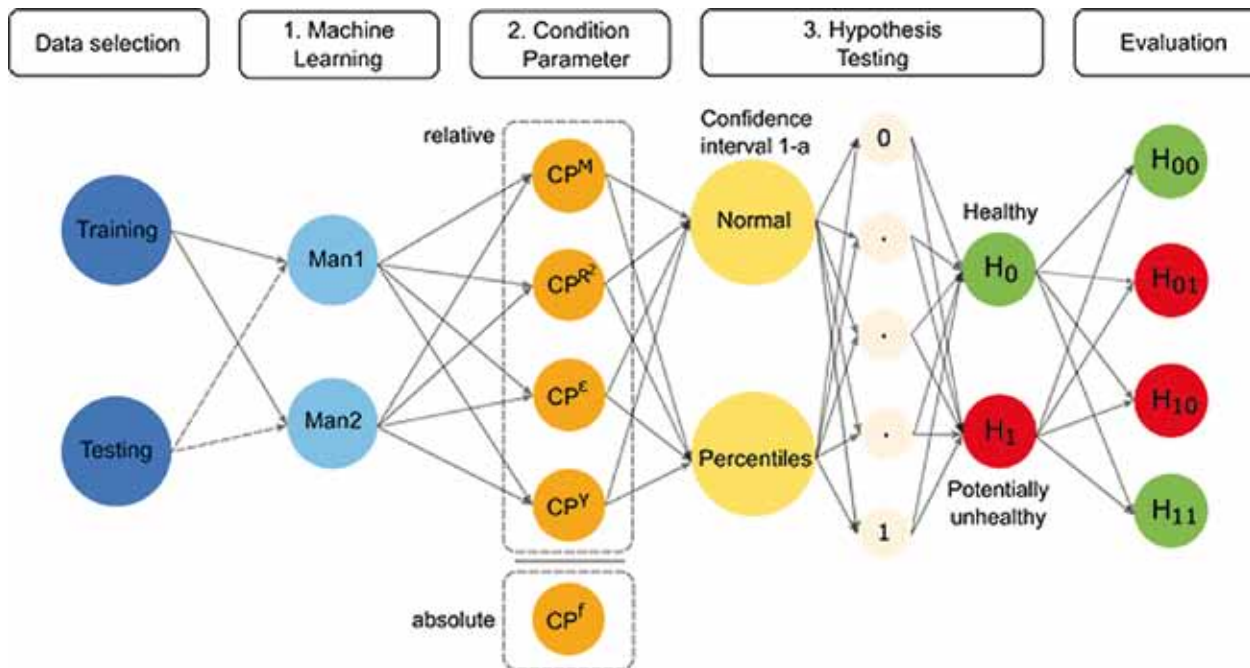

Figure 1: Modular SHM framework: Training and subsequently testing data instances are analyzed through a combination of a machine learning algorithm, condition parameters and probabilistic models

and assumptions for the CP distributions. Both provided detection of the damaged state of the blade for both cases of structural changes due to fatigue, damage occurrence at the trailing edge and propagation. The airborne sound damage detection algorithm detects the occurrence of the structural damage without a false detection. Events before the damage and events, where damage propagation took place, were detected without false alarms. The observation of the results of the two approaches showed that the comparison and combination of different damage indicators derived from different methods and physical quantities can be beneficial for SHM. The two approaches function complementary, since the CPs of the SHM-scheme provide information concerning the state of the blade (healthy or damaged), while the acoustic emission approach provides instantaneous information about damage events such as damage occurrence or propagation. Investigations for the application of both approaches under operating conditions belong to the future work of the authors. A more detailed description of the results be found in the final report of the project [3].



Figure 2: Fatigue test on a 34 m rotor blade and instrumentation

References

[1] ISET, Germany, http://www.iset.uni-kassel.de/pls/w3isetdad/www_iset_new.main_page
 [2] Gasch, R.: Eignung der Schwingungsmessung zur Ermittlung der dynamischen Beanspruchung in Bauteilen, PhD Dissertation, Technische Universität Berlin, Faculty of Mechanical Engineering, Berichte aus der Bauforschung Nr. 58 (1968)
 [3] Tsiapoki, S.; Krause, T.; Rolfes, R.; Ostermann, J.: Erweiterung und Erprobung eines Schadensfrüherkennungs- und Eisdetektionssystems für Rotorblätter von Windenergieanlagen – SHM.Rotorblatt: Abschlussbericht zum Forschungsvorhaben der Gottfried Wilhelm Leibniz Universität Hannover, Institut für Statik und Dynamik (ISD), Institut für Theoretische Nachrichtentechnik und Informationsverarbeitung (tnt), Leibniz Universität Hannover. (2016)

Monitoring Suction Bucket Jacket – Development of feasible Numerical Simulation Methods for the Investigation of the Compression and Tension Load bearing Behaviour and the Prediction of Displacement Accumulation

Leibniz Universität Hannover
Institute for Geotechnical Engineering
Martin Achmus, Christian Schröder, Klaus Thieken, Jann-Eike Saathoff, Tim Gerlach

Institute of Structural Analysis
Raimund Rolfes, Tanja Griebmann, Nikolai Penner, Andreas Ehrmann

Funding: Federal Ministry for Economic Affairs and Energy (BMWi)

Ref.Nr. 0325766A

Duration: 08/2014 – 02/2017

kum Riffgrund 1 in the German North Sea. The turbine was manufactured by Siemens and has a power of 4 MW (Type SWT 3.6/4.0 120 m). To date there is a lack of practical experience with such foundation structures under the typical load situations for offshore wind turbines (large horizontal and moment loading at relatively low static vertical loads with possibly large recurring tension loads). Consequently, there are neither standardized methods of calculation nor proof concepts available. Also validated structure models are missing that take the nonlinear and load history dependant soil structure interaction into account and with whom the bearing behavior due to cyclic and dynamic loads can be calculated.

Project Description

In this project both the installation and the bearing behavior of the foundation and the overall structure were observed intensively by a monitoring system. The measurements were used to validate the calculation methods and structural models developed in the project. The joint project Monitoring SBJ is divided into the three sub projects of the Leibniz University of Hannover (LUH), the company DONG Energy Renewables Germany GmbH (DONG) and the Federal Institute for Materials Research and Testing (BAM). The Federal Maritime and Hydrographic Agency (BSH) is an associated partner.

Introduction

The central eco-political goal of the Federal Government is to increase the share of renewable energies of the gross power consumption to about 80 % up to the year 2050. At present Germany is still in the beginning of extensive construction activity in the North Sea and Baltic Sea. More and more it has to be assumed that several construction projects have to be carried out simultaneously to accelerate the development of offshore wind energy and to reach the ambitious goals.

DONG Energy Wind Power has developed an innovative foundation structure in which an optimized industrially manufactured jacket is combined with suction buckets (hereafter called "SBJ"). The SBJ (see fig. 1) is designed for 5 - 8 MW turbines and water depths of up to 60 m and was installed in August 2014 in OWP Bor-



Figure 1: Design of the Suction Bucket Jacket of DONG Energy Wind Power [1]

LUH, DONG and BAM worked closely together on the subprojects under the coordination of LUH. The LUH subproject was executed by the Institute for Geotechnical Engineering (IGtH) and the Institute of Structural Analysis (ISD).

Summary

To reach the goals of this project several work packages were defined. The results of these work packages are summarized briefly in the following. More information is available in the final report [1].

Installation process (IGtH)

The soil exploration data delivered by DONG were checked and evaluated to derive a geotechnical soil model containing the relevant soil parameters for further calculations. Soil parameters were derived by CPT correlations and yielded best estimate, lower and upper bound soil profiles. Flow net calculations considering the former soil profiles were carried out to calculate the critical suction for certain boundary conditions like soil loosening or anisotropic water permeabilities. The critical suction is a limiting value for the admissible suction to prevent hydraulic failure during an installation. Parameter studies were carried out with three different analytical methods to simulate the installation process considering the previously obtained results. Back calculations using the measured data during the installation of the SBJ show that the recommended bandwidths of calibration parameters for the respective analytical methods can be regarded as suited for the considered installation.

Bearing capacity and deformation accumulation (IGtH)

The objectives within this work package were the investigation of the bearing behaviour of suction buckets under tensile loading in homogenous and especially layered subsoil. Besides pure axial tensile loading, inclined loads should be accounted for. In addition it was unclear, if a cyclic tensile loading package may lead to an accumulation of heave.

After a description of the state of the art, investigations were presented concerning the influence of a loose layer embedded in dense sand. It was shown, that especially for large heave rates, a loose layer nearby the tip has a significant influence on the evolution of suction pressure and therefore on the bearing behaviour. Additionally, the SBJ soil profiles were considered.

Within the investigations on heave accumulation due to cyclic tensile loading, the used material model hypoplasticity with its extension intergranular strain led to implausible results. Investigations with a simplified material behaviour indicate that cyclic loading with a load magnitude greater than the drained bearing capacity leads to an accumulation of heave. Thereby, the accumulation rate is dependent on the load magnitude.

Foundation stiffness (IGtH)

The nonlinear soil-structure interaction represents an essential part both for the design of the foundation as well as for the entire structure. Only a sufficiently accurate estimation of the foundation stiffness in the overall model allows the sustainable design of the structure by utilizing the existing soil resistances. At present, there are no approved spring approaches for describing the load-dependent foundation stiffness of bucket foundations. In order to determine the system-dependent resistances, it is therefore necessary to rely on very computationally expensive numerical continuum models. Furthermore, the rotational fixing dependence of the rising jacket structure results in a high complexity.

Based on these needed features, the development of an innovative interface between the geotechnical model and the overall model is presented, which allows the integration of the nonlinear foundation stiffness of any geotechnical model into the overall model without the use of an iterative procedure. The derived load-dependent stiffness matrices can then be integrated in the overall model by means of so-called superelements. It could be shown that the nonlinear foundation behaviour can be completely defined with a few load-controlled calculations and can be transferred to the overall

model with load-dependent stiffnesses. In a further step, the geotechnical modelling of the SBJ foundation was considered by 3D numerical models. The modelling of the overall model proved to be inappropriate, since the very high number of elements requires very large computing power. As a result, individual bucket models were developed that take the influence of the rising jacket structure on equivalent restraining conditions into account. Two approaches with different accuracy were developed. In the standard approach, the restraining action of the jackets is realized by a torsion spring, whereby the rotation of the jacket is neglected. Improved result of the behaviour can be achieved by an advanced approach with an influence on the torsion spring. The suitability of both models could be shown. Subsequently, an extensive parameter study was used to investigate the main parameters influencing the bucket foundation behaviour.

After applying the load-dependent stiffness matrices, using both approaches to the example of the SBJ prototype, the consideration of the foundation reaction was extended to un- and reloading conditions. It results in a lower nonlinearity, which cannot be assumed as a completely linear behaviour. This is different with a mono-foundation. The foundation reaction appears to be approximately linear when reloaded and the load-dependent foundation stiffnesses for monopiles consequently are dispensable. It should be emphasized that the developed interface can also transfer the post-cyclic load-bearing behaviour of any geotechnical model to the overall model and thus has more significance far beyond the work scope.

Measurement data analysis and system identification (ISD)

Within the scope of the work package extensive measurement data were analysed. The analysed data were used to identify the dynamic behaviour of the structure and to gain an improved understanding of the global load-bearing behaviour.

Data preprocessing could provide an important contribution to quality assurance by

using efficient algorithms on the basis of statistical values (metadata) and the comparison of redundant or correlated information.

To assess the influence of environmental and operational conditions on the global dynamic behaviour of the structure, a classification was performed. The essential influences were taken into account by means of wind speed, generator speed and pitch angle of the rotor blades.

The identified eigenfrequencies and mode shapes were representing the system parameters, which were identified by the operational modal analysis method Frequency Domain Decomposition. In addition to the usual identification based on acceleration measurements, all strain measurements were successfully used.

The histograms and probability density functions were used for the evaluation of the identified eigenfrequencies. All correction methods were considered separately to allow comparisons. In case of the second eigenfrequency of the suction bucket jacket, the influence of the environmental conditions could be removed to a high extent by calculation.

With the experience gained from the measuring system, the suitability of the existing measuring system can be assessed and improvements can be made.

Efficient modeling and model validation (ISD)

The simulation of the entire offshore wind turbine, consisting of rotor-nacelle-assembly, tower, and jacket substructure with suction bucket foundation, is an important enhancement in addition to the detailed investigation on the bucket. Here, effects of the foundation on the behavior of the whole structure can be regarded within the underlying model assumptions.

At first, the structural model is described based on the available design documents. The soil-structure-interaction of the installed buckets, located in the North Sea, is represented as a reduced model at one node

with six degrees of freedom and considered as linearized for a certain operating point. A preliminary study examines a more precise numerical modeling of the tubular joint stiffness in terms of its influence on the structural eigenfrequencies.

Based on this, a three-step global sensitivity analysis (one-at-a-time analysis, regression analysis, variance-based sensitivity analysis) is conducted to detect those design parameters, which affect the regarded eigenfrequencies the most.

Finally, a model updating (or model calibration) is carried out with this reduced set of parameters to adjust the lower eigenfrequencies and mode shapes of the numerical model according to the results from measurement data of the real structure in idling position. Here, an evolutionary algorithm is applied for optimization.

Hydrosound measurements (ISD)

The goal of this work package was the provision of the experimental proof that the installation process of the SBJ is a low-noise construction method. The hydrosound measurements and evaluations were conducted by itap GmbH (Institut für technische und angewandte Physik GmbH, Oldenburg). The noise levels were measured at three positions before, during and after the installation process. A comparison with measurements of the background noise before the installation shows that the permanently existing background noise is clearly increased by the noise of the accompanying construction ships but the actual installation process of the SBJ does not lead to a further increase of hydrosound in a distance of at least 500 m. The hydrosound measurements thus confirm the assumption of a low-noise construction method.

References

- [1] Achmus, M. : Verbundprojekt: Monitoring Suction Bucket Jacket – Monitoring SBJ. Final Report, Leibniz University of Hannover, Institute for Geotechnical Engineering, (2017)

Multivariate Structural Health Monitoring for Rotor Blades

Leibniz Universität Hannover
Institute of Structural Analysis

Marlene Bruns, Aamir Dean, Christian Gerendt, Tanja Griebmann, Eelco Jansen, Helge Jauken, Dorian Pache, Raimund Rolfes

Funding: Federal Ministry for Economic Affairs and Energy (BMWi)

Ref.Nr. 0324157A

Duration: 03/2017 – 02/2020

Introduction

As one of the main renewable energy resources, wind energy has gained an important role in the generation of sustainable energy. For this reason, the aim to achieve a high degree of utilization as well as the aim to enhance the durability of wind turbines became vital research topics. Therefore, the ability to identify structural damage and consequently prevent component failure is a significant tool of interest in relation to flexible service intervals and condition-based maintenance of wind turbines. Since the rotor blades represent a centerpiece of a wind turbine, their failure means downtime for weeks or even months, resulting in high repair costs. This is why rotor blades are counted among the leaders in terms of the duration of the downtime and the repair costs caused by their failure, although they are not leading in terms of damage frequency [1].

Essential goals of the project “Multivariate Structural Health Monitoring for Rotor Blades” (MultiMonitorRB) are the development, the combination and the testing of global as well as local structural health monitoring (SHM) methods for rotor blades

of wind turbines. The investigations are carried out first on a destructive fatigue testing of a large-scale rotor blade in a laboratory setup (cf. Figure 1) and subsequently on an operational offshore wind turbine. Thereby, a unique characteristic of this joint research project includes the full knowledge of the geometry and the material properties as well as information about the blade manufacturing of the exploratory rotor blade.

Project Description

Monitoring systems are an important requirement for increasing system availability and reducing the costs. Still, damage monitoring systems are not yet well established, because there do not exist clear limits that detect damage and can thus give a clear warning. Furthermore, there exist many different rotor blade designs that have differing properties. Even blades of the same production show differing structural behavior due to the manual manufacturing process. This is why fundamental investigations of the damage development mechanisms are necessary, which can only be carried out with

a detailed numerical model. Therefore, the integration of the fully available rotor blade data into the development of SHM processes represents such a unique characteristic of MultiMonitorRB. In most research projects, this knowledge is not fully available, since it is normally strongly protected by the wind turbine manufacturer.

Based on the design data of the rotor blade, a detailed numerical model is created. On the one hand, this model enables the application of model-based SHM methods. On the other hand, it is used for the simulation of material fatigue via damage evolution as well as for the assessment of residual strength. In addition, a central new idea in the project is the combination of numerical simulation models with data-driven SHM methods.

In order to estimate the material fatigue occurring in the rotor blade during the fatigue testing, a so-called Fatigue Damage Model (FDM) is implemented. The model bases on the idea of [2], which expands the linear damage accumulation theory (cf. Palmgren-Miner approach [3]) with a non-linear fatigue model. The measured data recorded



Figure 1: Testing of a large-scale rotor blade at the Fraunhofer Institute for Wind Energy Systems in Bremerhaven

during the testing then serve to validate the simulation results.

A preliminary simulation of the fatigue testing was performed under defined test conditions, including an edgewise excitation up to one million cycles. Results showed that a matrix-dominated fatigue damage of areas located at the leading and trailing edge is to be expected. Especially the areas at the trailing edge between 5 and 10 m from the hub-end (cf. Fig. 2) as well as at the leading edge located 6 m from the hub (cf. Fig. 3) show significant fatigue damage.

The definition of different load scenarios as well as different test conditions is to simulate different damage scenarios, which gives additional information on the sensitivity of different features with respect to the occurred damage. This information is used to investigate and develop data-driven methods that identify condition parameters used to monitor the structural health. In addition, knowledge about the sensitivity of the different features is used to identify suitable features for model-based SHM.

First steps concerning model-based SHM were conducted on a simple beam model of the large-scale rotor blade. Since the testing was not yet performed, a reference model and a model with an artificially induced damage were created. The damage was assumed to be material fatigue, simulated by a stiffness reduction. An initial study showed that an increase of design variables results in an objective value space with many local minima, making numerical optimization unfeasible [4]. Therefore, approaches are needed that minimize the amount of design variables and thus, the dimension of the optimization problem. Most common methods use the assignment of one design variable to a group of finite elements having similar mechanical properties [5, 6]. Within this project, an alternative approach is analyzed that uses a damage distribution function, which can be described only by few variables. Fig. 4 illustrates a damage distribution function designed for two-dimensional beam structures, resulting in three design variables. Of course, the goal is to apply this damage distribution function to a three-

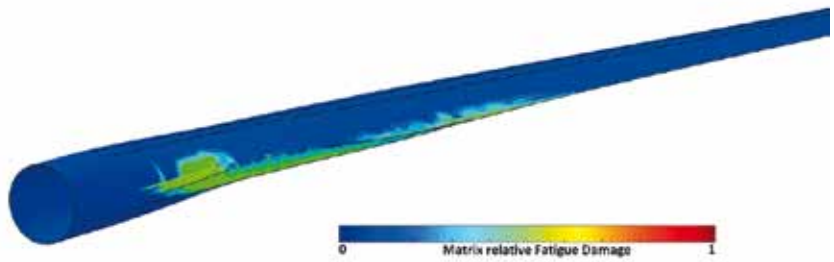

Figure 2: Matrix-dominated fatigue damage at the trailing edge

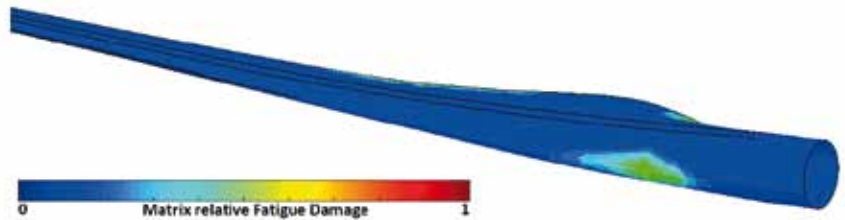

Figure 3: Matrix-dominated fatigue damage at the leading edge

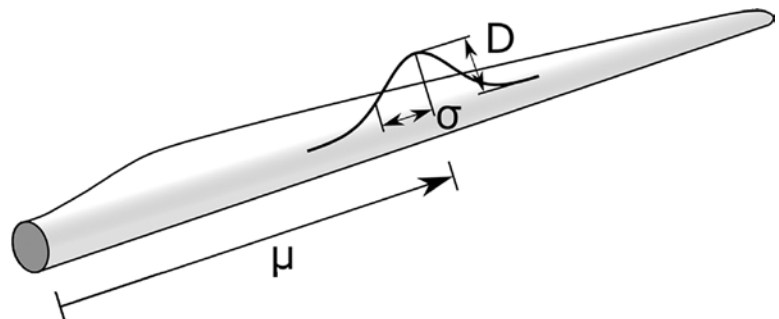

Figure 4: Parameterization of the damage distribution function along the blade length for a two-dimensional model

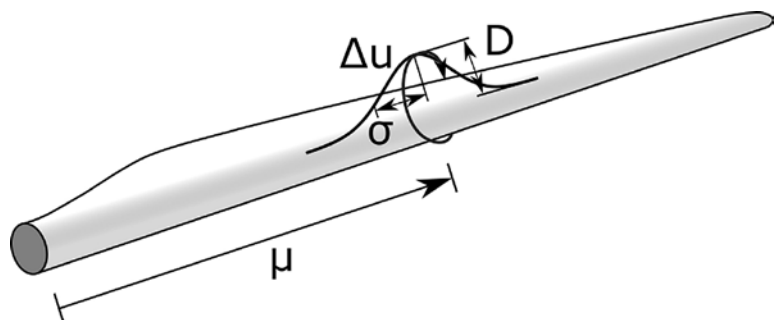

Figure 5: Parameterization of the damage distribution function along the blade length for a three-dimensional model

dimensional shell model, resulting in an additional fourth design variable, representing the peripheral direction (cf. Fig. 5).

Due to the use of various SHM systems within this joint research project, a harmonization and temporal synchronization of the differing measuring systems have to be planned and carried out. Only if these conditions are met, a comparability of the acquired measurement data and thus, the detection results is ensured among the project partners. At ISD, an electrical and a fiber optical measurement system as well as electrical and fiber optical accelerometers were purchased and are currently being prepared.

Summary

The aim of the project MultiMonitorRB is the development, combination and testing of SHM methods, that are able to capture different features and damage indicators. In sense of a multivariate procedure, different vibration-based and acoustic SHM approaches are considered. These SHM methods are to guarantee an automated and reliable detection, localization and classification of relevant damages during the early stage.

The project sets an important milestone by uniting data-driven SHM methods with numerical simulation methods using fully known rotor blade design data. This procedure promises to gain knowledge, very likely resulting in better damage detection and localization procedures.

References

- [1] Hahn, B.: Schadensstatistik von WEA und präventive Schadensvermeidung, Windenergie NRW, November 29-30, 2012, Bad Driburg, Deutschland
- [2] Krueger, H.: Ein physikalisch basiertes Ermüdungsschädigungsmodell zur Degradationsberechnung von Faser-Kunststoff-Verbunden, PhD thesis, Institute of Structural Analysis, Leibniz Universität Hannover, Deutschland, 2012
- [3] Miner, M. A.: Cumulative Damage in Fatigue, *Journal of Applied Mechanics* 12 (1945), pp. 159-164
- [4] Bruns, M.; Hofmeister, B.; Pache, D.; Rolfes, R.: Finite element model updating of a wind turbine blade – a comparative study, in: *EngOpt 2018 Proceedings of the 6th International Conference on Engineering Optimization*, Springer International Publishing, 2019, pp. 569-580
- [5] Schroeder, K.; Gebhardt, C. G.; Rolfes, R.: A two-step approach to damage localization at supporting structures of offshore wind turbines, *Structural Health Monitoring* 17 (5), pp. 1313-1330, (2018)
- [6] Levin, R.; Lieven, N.: DYNAMIC FINITE ELEMENT MODEL UPDATING USING SIMULATED ANNEALING AND GENETIC ALGORITHMS, *Mechanical Systems and Signal Processing* 12 (1), pp. 91-120 (1998)

Development and Validation of a Virtual Process Chain for Composite Structural Components Considering Imperfections with Application to a Rotor Blade Component (PROSIM R)

Leibniz Universität Hannover
Institute of Structural Analysis

Raimund Rolfes, Benedikt Daum,
Eelco Jansen, Gerrit Gottlieb

Universität Bremen
Institute for Integrated Product
Development (BIK)
Klaus-Dieter Thoben,
Jan-Hendrik Ohlendorf,
Likith Krishnappa

Funding:
Deutsche Forschungsgemeinschaft (DFG)

Project Nr. 329147126

Duration: 08/2017 – 08/2020

Introduction

Rotor blade development is driven by increasing performance and cost requirements. In this context, the shortening of cycle times during production, quick adaptation of the production process to changed materials and quality-control of rotor blades are becoming increasingly relevant. These issues are of particular concern, since manual labor is still the main method of production. It is thus essential to acquire a deeper understanding of how the manufacturing process affects the resulting mechanical behavior. These issues define the scope of the research project, 'PROSIM R'. The main aim of this project is to predict imperfections and process fluctuations in composite components via a series of linked process simulations. Results from these process simulations then form the basis for subsequent mechanical analyses.

Project Description

A major issue in the industrial application of fiber-reinforced composites is the establishment of a reliable, fast and cost-effective manufacturing process. Production-related manufacturing defects can significantly reduce the laminate quality. In order to optimize the production process, it is therefore essential to determine precisely the influence of manufacturing defects on the material properties.

In a consortium of three project partners, the research project, PROSIM R aims to investigate essential parts of the process chain of a rotor blade by numerical and experimental techniques. The following sub-processes are considered: handling and draping of the reinforcing flexible textile, infusion and impregnation with matrix resin and curing and finally the mechanical analyses of the reinforced fiber composite. The results from each process step are passed on from one process simulation to the next (see Fig. 1). Thus, the project PROSIM R extends the current state-of-the-art models which only considers individual process-steps and not process simulation as a whole. This strategy allows the project, PROSIM R to overcome a the major drawback which is the actual representation of imperfections (e.g. voids or geometric deviations of the fiber path) in mechanical analysis due to the lack of accurate data. In the project PROSIM R, the imperfection data is predicted via the manufacturing processes, rather than making use of some assumptions. Parameters characterizing different kinds of imperfections, such as roving undulation or the local resin saturation, are predicted at the appropriate stage in the simulation chain and are passed on to the next stages of simulation. For roving undulations and resin saturation, which

are mentioned as examples here, the appropriate data is gathered at the handling and at the infusion stage respectively. As an outcome of the manufacturing simulation, all the necessary information about the relevant imperfections are available for the final mechanical strength analysis of the composite component. In the mechanical analysis, the influence of manufacturing process-related defects on the linear and non-linear structural-mechanical behavior is then quantified via systematic numerical investigations.

Since imperfections occur at fundamentally different length scales, both the process simulations as well as the mechanical analysis are based on a multi-scale approach. Following a sequential homogenization multiscale scheme, mechanical simulations are first performed for the fiber-matrix micromechanical model in order to predict the effective material behavior of a roving (micro scale). The material parameters determined by homogenization of the micro scale models are then used at the next scale level defined by the roving architecture (meso scale). The material properties resulting from the second homogenization are then available as effective properties for structural simulations at component scale (macro scale). In the course of this multi scale process, imperfections are represented on each of the three scale levels, as necessary.

Many imperfections can be characterized only by statistical distributions of parameters, rather than single-valued deterministic parameters. For example, the volume occupied by a void is random for every void instance, however, the void-volume still follows a certain frequency distribution. In order to ensure a correct representation of such statistical properties, probabilistic

analyses are performed from information which can be obtained from the manufacturing process simulations.

Validation of the numerical models will be performed at each scale level, so that the possible modelling errors can be isolated and subsequent improvements are facilitated. Also, in the case of the micro and meso scale models, validation of statistical quantities will be attempted by testing a series of appropriately designed coupons. At component scale, only a small number of tests can be carried out due to financial constraints, thus, one or a few static tests will be carried out for a representative structural component, i.e. a segment of the rotor blade spar-cap.

Summary

The project is application oriented. Expected results from the project will improve the accuracy of static strength prediction of practical, and thus imperfect, rotor blades based on information available from the manufacturing process. Moreover, the project is expected to illuminate the relative and absolute impact of typical imperfections on the static strength of fiber reinforced composite components in general. This is expected to lead to further advances in material development, especially for the integration of new materials into existing processes. Currently, complex test series are necessary to adapt manufacturing processes when changing materials. A virtual process chain dramati-

cally reduces the number of necessary tests. Furthermore, the developed methods can account for the influence of manufacturing imperfections on the structural-mechanical behavior of a finished component and can help to determine the fault tolerances during the manufacturing processes. Respective criteria and design rules for fault tolerances could help in reducing scrap and facilitate the certification processes.

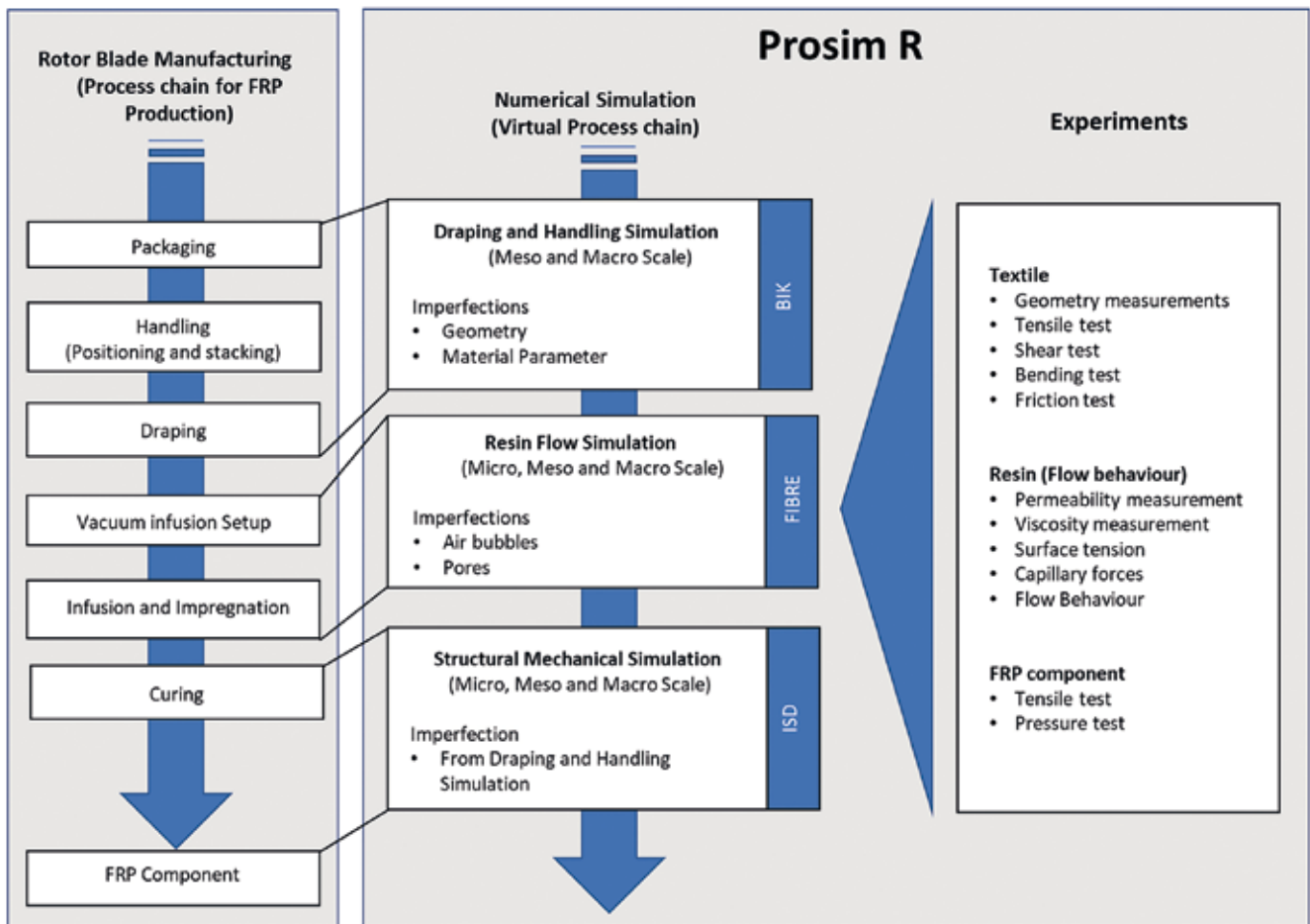

Figure 1: Representation of the process simulation of rotor blade production planned in the PROSIM R project

INFLOW-Noise

Carl von Ossietzky Universität Oldenburg
Institute for Physics,
Research Group: Turbulence, Wind Energy
and Stochastics

Joachim Peinke, Michael Hölling,
Ingrid Neunaber

Funding: Federal Ministry for Economic
Affairs and Energy (BMWi)

Ref.Nr. 0325459B

Duration: 10/2012 – 09/2016

Introduction

The project INFLOW-Noise aims at the investigation of the sources of leading and trailing edge noise of rotor blades in turbulent flows. Reducing the noise emission is of major concern to support the acceptance of wind energy converters (WECs) and to fulfill noise regulations at new sites. In cooperation with the Fraunhofer IWES, the Institute of Aerodynamics and Gas Dynamics (IAG) of the University of Stuttgart, the Institute for Technical and Applied Physics (itap) and GE Wind Energy, the noise sources are examined with computational fluid dynamics (CFD) simulations that are validated with wind tunnel experiments on an airfoil at the University of Oldenburg. The experiments include acoustic measurements with a directional microphone array and a sound level meter and flow measurements with hot wires as well as measurements of the pressure and the pressure fluctuations on the surface of the airfoil.

Project Description

During the previous reporting period most of ForWind's work within this project has been finished. This included mainly the design and assembly of a setup to fulfill the following requirements: First, all experiments should to be executed in turbulent flows with atmospheric-like properties to ensure the applicability to wind energy. Second, the background sound pressure level coming from the setup had to be low enough to be able to decompose the leading and trailing edge noise from the background. Third, the flow characteristics of the final setup had to be characterized. Additionally, all the measurements have been performed.

During the current reporting period, a detailed report on the measurements and the data handling was written. It contains detailed information on the setup, the measurements from July 2014 and the methods used to process and analyze the data. Additionally, the results were presented at the DAGA 2015 in Nuremberg in a talk, "Experimentelle Untersuchung des Vorder- und Hinterkantenlärms eines Profils in Turbulenter Strömung".

The acoustic measurements that were carried out by the itap were further processed, and a report on the measurements was presented. The results indicate a localization of noise sources ranging from about 630 Hz to about 2500 Hz at the leading edge of the airfoil. This is in accordance with the results from the measurements taken with the sound level meter, as in this frequency range the sound pressure level of the setup with airfoil exceeds the sound pressure level of the setup without airfoil. The angular resolution of the directional microphone array is not sufficient to distinguish between different angles of attack.

Summary

The measurements carried out to validate the results of the CFD simulations were processed and a report on the measurements was written. Results were presented at the DAGA 2015.

References

- [1] Wächter, M.; Heißelmann, H.; Hölling, M.; Morales, A.; Milan, P.; Mücke, T.; Peinke, J.; Reinke, N.; Rinn, P.: The turbulent nature of the atmospheric boundary layer and its impact on the wind energy conversion process, *Journal of Turbulence*, Vol. 13, No. 26, p. 1-21 (2012)

WEA-Akzeptanz – From the Source to the Perception

Leibniz Universität Hannover
Institute of Structural Analysis

Raimund Rolfes, Tobias Bohne,
Jasmin Hörmeyer, Susanne Martens

Funding: Federal Ministry for Economic
Affairs and Energy

Ref.Nr. 0324134A

Duration: 04/2017 – 03/2020



Logo of the project WEA-Akzeptanz

Introduction

Public acceptance of wind turbines is essential for the successful transition of energy resources towards renewable sources. Due to the expansion of wind power near to populated areas, the public acceptance of wind turbines has decreased in the last few years. The social development towards wind turbines needs to be positive in order to achieve the objectives in the area of energy system transformation. Since local residents complain in particular that they feel disturbed by noise immission, it is important to make citizens aware of actual noise effects of wind turbines.

The project “WEA-Akzeptanz” addresses this requirement and aims at the prediction and objectivity of noise effects on the residents. For this, an interdisciplinary approach is applied linking the sound generation, radiation and propagation of wind turbines with the psychoacoustic evaluation at the immission site (see fig. 1). For this purpose, the industrial manufacturer Senvion examines the sound generation and radiation. The Institute of Structural Analysis and the Institute of Meteorology and Climatology of the Leibniz Universität Hannover investigate the sound propagation under realistic atmospheric conditions, whereas the Institute of Communications Technology analy-

ses the perception at the immission site. In cooperation with the partners an acoustic overall model will be developed. The model will include sound generation and sound propagation, as well as the psychoacoustical assessments. The latter is especially important for the public acceptance. In order to validate the different models and the overall model, extensive field measurements are performed to monitor acoustical, meteoro-

logical and wind turbine parameters under different environmental conditions. The influence of operational parameters and noise reduction technologies are evaluated. Using the validated model, the noise effect on the residents will be objectified and made predictable. The overall acoustic model could be also used in the planning stage of wind farms.

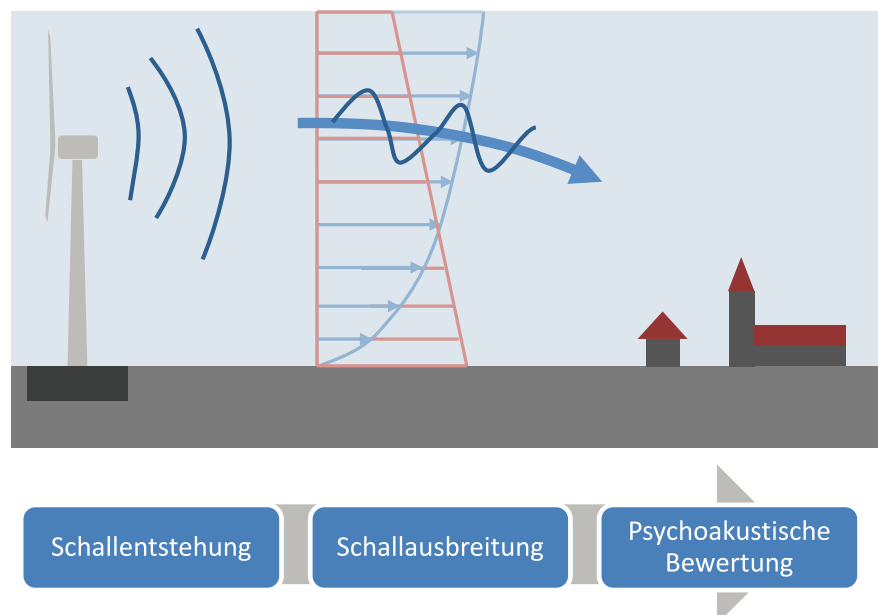

Figure 1: Concept of the overall acoustic model

Project Description

First, the challenges of the entire transmission chain from sound generation to the psychoacoustical part are described. Then, the overall acoustic model and measurements are presented.

Transmission chain of the sound

The generation of noise emissions caused by aeroacoustic phenomena on the rotor blade is already very complex. In addition, several noise sources emit individual tones due to rotating components (gears, fans, servomotors, pumps). Aspects such as aging or production-related tolerance deviations ultimately ensure that each wind turbine has its own individual "sound footprint". Even small deviations - such as a ventilation hatch in the tower or production deviations of a few centimeters in the rotor blade or an alternative manufacturer of critical components - can lead to significant shifts in the resulting sound spectrum. Critical sound phenomena are often only detected during field measurements. As a result, actions against these phenomena can only be carried out very late in the design process or even in the field and are therefore associated with correspondingly high costs.

Due to the large distances between the residential areas and the wind farms, the sound generated by a wind turbine is not equal to the sound perceived as noise from citizens. Depending on topography and changing atmospheric conditions (i.e. wind and temperature distribution), the sound propagation is frequency and location-dependent.

The transmission chain ends with the directly affected residents who have their own subjective perception of the "sound footprint". This is connected to the associated psychoacoustic evaluation of sound immissions. If residents feel subjectively disturbed by the sound of wind turbines, the critical values which are defined in guidelines are irrelevant for them. The guidelines determining sound immissions insufficiently consider phenomena such as sound modulations. For the residents, the emotional perception and thus the

psychoacoustic evaluation of the sound immissions of a wind turbine is of greater importance and thus ultimately decisive. The emotional perception is also closely linked to the visual perception of the wind turbines.

Model

The overall acoustic model serves to predict and objectify the noise effects of wind turbines on local residents. In the model, the entire transmission chain from the sound source to the sound receiver (point of immission) will be linked. Because of different requirements and the complexity of the transmission chain, the overall acoustic model will be separated into submodels. These submodels includes a model of the sound generation in the near field, a model of the sound propagation in the far field and a model of the psychoacoustic annoyance at the point of immission.

The development of the near-field model for sound generation is divided into two areas. This includes the model of aerodynamic sound generation, which shows aging phenomena, special operating conditions and wind farm effects. In addition, the near-field model includes structural vibrations and the resulting sound radiation as well as the stimulation and transmission of structure-induced sound by wind turbine specific components. For the development of the far field model, important atmospheric parameters influencing the sound propagation (temperature, wind, turbulence, etc.) are defined on the basis of a meteorological model. Subsequently, these atmospheric parameters as well as the effects of topography and vegetation are included in the far-field 1 model so that sound propagation can be evaluated under realistic atmospheric conditions. A psychoacoustic model will be developed at the point of immission to investigate the loudness and annoyance of wind turbine operating noises and to evaluate and optimize the noise development with regard to minimum annoyance in various work and life situations (sound design). In addition, the immission site will be created as an audiovisual 3D simulation environment for the psychoacoustic evaluation of wind

turbine noise, including simulations of various weather and operating conditions. Subsequently, the individual submodels are coupled to form a complete acoustic model. The overall acoustic model can be validated with the help of the measurement campaigns carried out.

Measurements

Due to many circumstances, measurements in the field and near to wind turbines are challenging. The biggest challenge is the capability of measurement data to validate the complex model. The data needs to provide the quantification of different physical and range-dependent effects. Different ground and weather conditions, the topology, and the wind turbines with their individual source characteristics affect the sound. For this reason, the project includes four measurement campaigns monitoring acoustic, meteorology and wind turbine parameters. The first experimental campaign will be carried out in 2018, lasting seven weeks in the northern part of Germany. This test site is characterized by simple environmental conditions i.e. flat landscape and less natural cover. Later sites will include complex environmental conditions and different types of wind turbines. An overview of an overall measurement setup is shown in fig. 2. The measurement equipment for psychoacoustic investigations and examination of wind turbine sound propagation is seen in fig. 3 to 6.

Due to the requirement to measure under free field conditions, acoustic measurements present further challenges. Besides non-technical challenges such as finding a suitable site with low background noise, the wind turbine itself is a complex source and hence hard to measure. At greater distance to the source, the separation of background noise and sound emission from wind turbines is identified as a further challenge. It is hard to get a high signal-to-noise ratio due to the fact that the wind turbine sound and the background noise is increasing with higher wind speeds. The background noise is characterized by noise from leaves and vegetation in general as well as by wind-induced noise on microphones.

To meet the presented challenges during acoustic measurements, a suitable measurement setup was developed. To minimize the influence of wind-induced noise a standard windscreen and a specific developed secondary wind screens will be used reducing the atmospheric turbulence incident on the microphone. Moreover, acoustic measurement station will be placed as far as possible but at least 10 m away from trees or buildings. An example of an acoustic measurement station including a secondary wind screen and a solar panel for external power is shown in fig. 3.

Summary

Noise emissions caused by wind turbines receive a lot of attention in politics and is of public interest. Public acceptance of wind turbines is essential for the successful transition of energy resources towards renewable sources. The wind energy project “WEA-Akzeptanz” addresses this requirement, and aims the development and validation of an overall acoustic model, which includes the sound generation, radiation and propagation from wind turbines, and the psychoacoustical assessments at the immission site. Using the validated model, the noise effect on the residents will be objectified and made predictable. The overall acoustic model could be used in the planning stage of wind farms. More information about the project “WEA-Akzeptanz” and the ongoing research activities are found at the website www.wea-akzeptanz.uni-hannover.de.

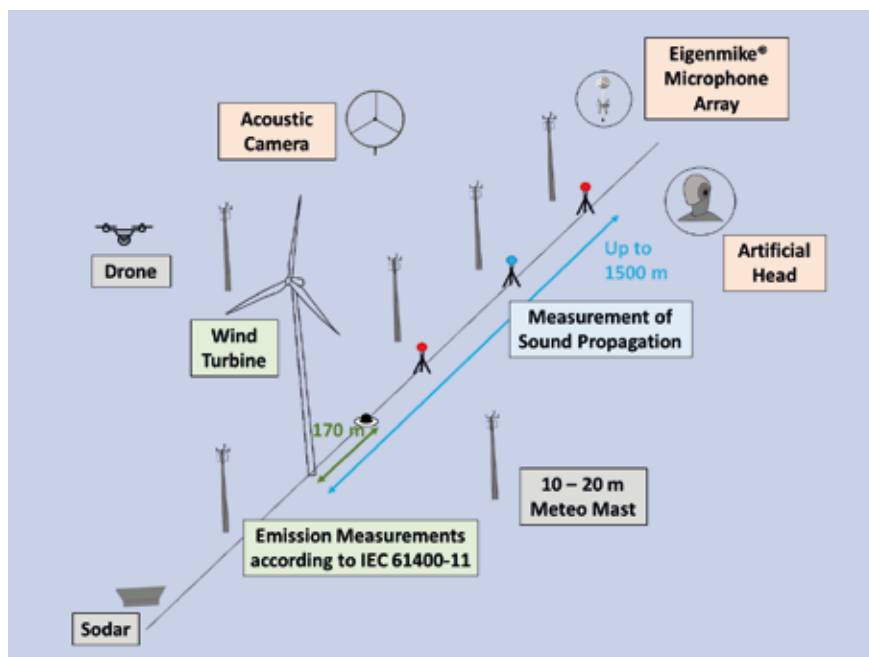

Figure 2: Schematic measurement setup for psychoacoustic investigations and examination of wind turbine sound propagation



Figure 3: Acoustic measurement station to monitor wind turbine noise



Figure 4: Mast for long-term measurement of wind speed and direction, temperature and humidity



Figure 5: Multicopter and sodar to measure vertical wind-profiles



Figure 6: Measurement setup for the psychoacoustic evaluation of wind turbine noise

Generation of Realistic Turbulent in-Flow Conditions by an Active Grid, Stochastic Analysis of the Resulting Force Dynamics on 2D Segments of Airfoils with Active Control Units

Carl von Ossietzky Universität Oldenburg,
Institute of Physics,
Research Group: Turbulence, Wind Energy
and Stochastics (TWiSt)

Gerrit Kampers, Agnieszka Hölling,
Michael Hölling, Joachim Peinke

Funding: German Research Foundation
(DFG)

Ref.Nr. PE 478/15-1

Duration: 01/2013 – 12/2015

Introduction

Wind turbines work within the atmospheric boundary layer (ABL), which is dominated by turbulence. In such turbulent flows, gusts occur much more frequently on short time scales than estimated by Gaussian statistics, which are used in industry standards [1]. This effect is called intermittency, which has a big impact on mechanical load fluctuations and is considered to increase wind turbine failure rates [2]. Active and passive flow control elements represent a promising approach for the reduction of these changing forces and loads. In the present project, a new method for wind tunnel experiments is adopted, that allows an advanced investigation of the dynamics of aerodynamic forces acting on airfoil segments with and without control units with reproducible turbulent inflow conditions. Based on an analysis of wind data, dominant features are reproduced in the wind tunnel by means of an active grid. To study the resulting force dynamics, we use a stochastic method, that allows for a quantitative analysis of the dynamical performance of airfoils with and without flow control elements.

Project Description

Preliminary work

Locally at the rotor blades, the resulting inflow is influenced by fluctuating wind speeds and directions and the rotational movement of the blades. In the first phase of this project, this local inflow was estimated based on an analysis of offshore wind data. The fluctuations of the local inflow angle of attack γ were analysed by means of increment statistics, where the increment

$$\hat{\partial}_\tau \alpha = \alpha(t+\tau) - \alpha(t)$$

describes changes of $\alpha(t)$ on the time lag τ . It could be shown, that the intermittent nature of the wind data is directly transferred to the local inflow at the turbine's blades.

An experimental setup was built to test airfoils in different reproducible inflow conditions created by an active grid. The setup was successfully tested for periodic inflow situations. Furthermore, the stochastic Langevin approach was applied to lift data of an airfoil in turbulent inflow in a first test.

Measurement of aerodynamic quantities

In the second phase of the project, a Self-Adaptive Camber equipped Clark-y airfoil segment (ACP) is tested in different unsteady inflow conditions. The profile features coupled leading- and trailing edge flaps, allowing it to passively adapt its camber [3]. The mechanism can be blocked to stay in the Clark-y shape (fixed case).

The experimental setup was modified, using only the vertical axes of the active grid. With this setup, quasi 2D angle of attack fluctuations can be created without moving the airfoil itself, which prohibits influences of inertia on the ACP mechanism. A sketch of the setup is shown in fig. 1.

The active grid allows to reproduce different features of the estimated local inflow

conditions on wind turbine blades. In the following example, we generated two inflow situations varying the intermittency of inflow angle fluctuations, while keeping its mean value and standard deviation almost constant. Fig. 2 shows probability density functions (PDF) of measured lift coefficient increments of the ACP for low intermittency (left) and high intermittency (right), each for the adaptive camber (dashed lines) and the fixed case (solid lines). Both cases are normalized by the standard deviation of the increments in the fixed case. The angle of attack with respect to the mean inflow is 8° . The different inflow statistics are captured in the lift. This indicates, that mechanical loads of wind turbines likely also feature intermittent statistics. For both inflow cases, the Adaptive Camber mechanism clearly attenuates lift fluctuations on different time-scales.

Stochastic analysis

To analyse the dynamical response of the ACP to turbulent inflow in a quantitative way, we apply the stochastic Langevin approach. The Langevin equation

$$\frac{d}{dt} C_L = D^{(1)}(C_L) + \sqrt{D^{(2)}(C_L)} \cdot \Gamma(t)$$

decomposes fluctuations of C_L into a deterministic and a stochastic part, where $\Gamma(t)$ is Gaussian δ -correlated white noise. The drift and diffusion coefficients $D^{(1)}$ and $D^{(2)}$ describe the deterministic relaxation of the system to its desired steady state $D^{(1)}=0$ and the stochastic part of the system and can be obtained directly from measurement data [4].

To filter mechanical vibrations in the setup from measured lift data, we apply an Empirical Mode Decomposition and exclude modes containing periodic oscillations from our signals prior to the stochastic analysis. This method has been successful in a similar problem [5].

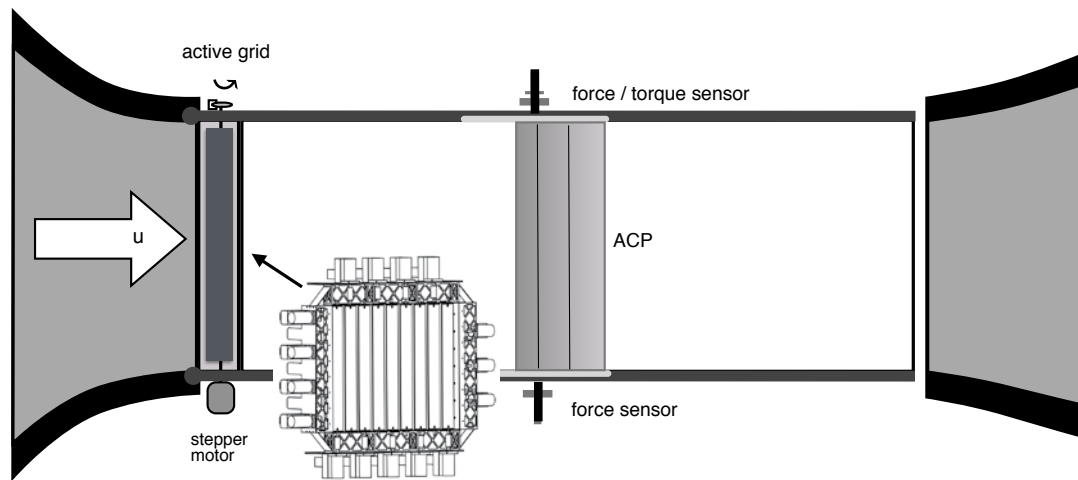

Figure 1: The ACP in the closed test section of the wind tunnel downstream of the active grid.

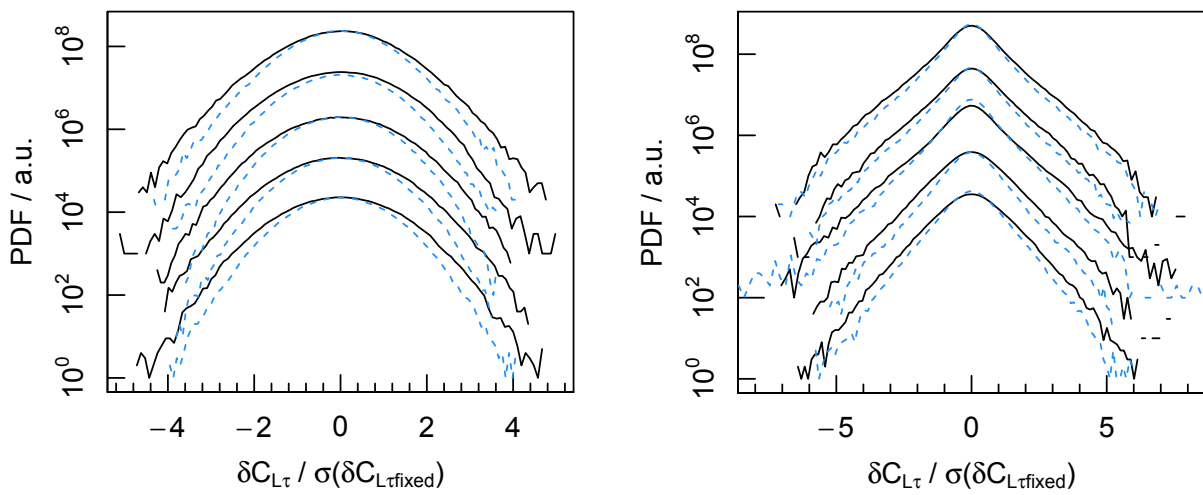

Figure 2: PDF of lift increments of the ACP (dashed lines) and fixed case (solid lines). The graphs are vertically shifted. From top to bottom Γ takes the values of 0.007, 0.014, 0.042, 1 and 3s.

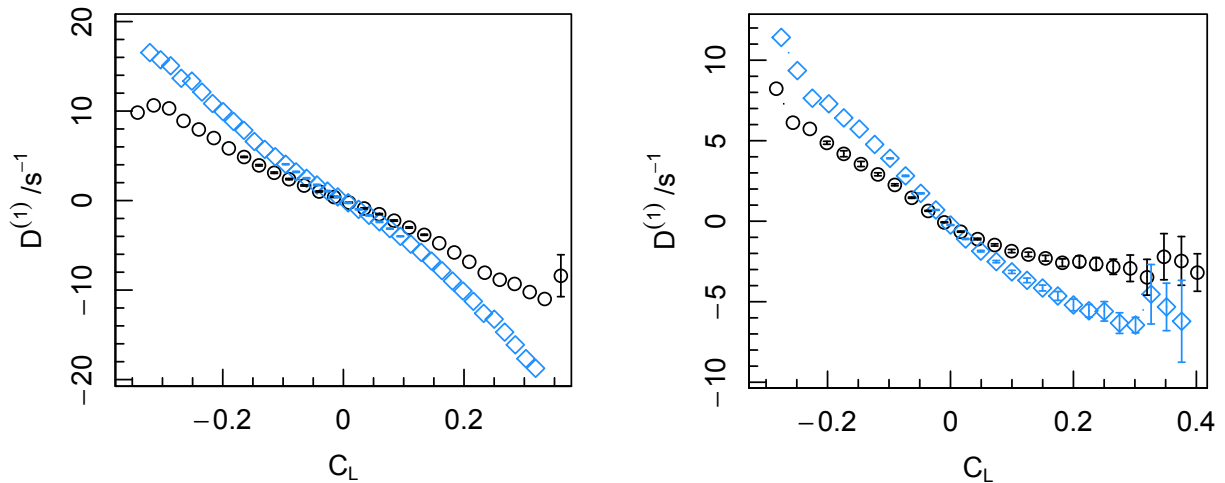

Figure 3: Deterministic drift function of the measured lift force dynamics of the ACP (black) compared to the fixed case (blue).

Fig. 3 shows the drift coefficient of the lift for the previously shown low intermittency (left) and high intermittency (right) inflow cases for the ACP (blue) compared to the fixed case (black).

The deterministic drift is clearly increased by the ACP, indicating a stronger tendency to its fixpoint when perturbed by fluctuating inflow, resulting in a smaller probability for fluctuations. The system has a stronger resistance to an external excitation, for example induced by a gust and responds quicker to a deviation from its fixpoint. Consequently, the fluctuations of the lift are reduced by means of standard deviation and extreme values, without significantly affecting the underlying dynamics.

Summary

In the present study, we experimentally tested a Self-Adaptive Camber airfoil, that has the potential to alleviate turbulence induced lift fluctuations. The airfoil was tested in turbulent inflow, generated by an active grid.

To analyse the effect of the adaptive camber on the dynamics of the lift fluctuations, we applied a stochastic approach based on the Langevin equation, that provides additional information about the resistance of the system to turbulent excitation. The response time of the system to excitation is captured. This information could become helpful for future studies on fatigue loads.

References

- [1] Mücke, T.; Kleinhans, D.; Peinke, J.: Atmospheric turbulence and its influence on the alternating loads on wind turbines, *Wind Energy* 14, p. 301 (2011)
- [2] Taver, P.; Qiu, Y.; Korogiannos, A.; Feng, Y.: The correlation between wind turbine turbulence and pitch failure, *EWEA 2011*, p.149
- [3] Lambie B.: Aeroelastic Investigation of a Wind Turbine Airfoil with Self-Adaptive Camber, doctoral thesis, Technical University of Darmstadt (2011)
- [4] Friedrich, R.; Siegert, S.; Peinke, J.; Lück, S.; Siefert, M.; Lindemann, M.; Raethjen, J.; Deutschl, G.; Pfister, G.: Extracting model equations from experimental data, *Phys. Lett. A*, Volume 271, Issue 3, pp. 217-222, 200
- [5] Hadjihosseini, A.; Peinke, J.; Hoffmann, N.P.: Stochastic analysis of ocean wave states with and without rogue waves, *New Journal of Physics*, Vol.16 (2014)

Advanced Aerodynamic Tools for Large Rotors – AVATAR

Carl von Ossietzky Universität Oldenburg
Institute of Physics,
Research group TWiSt

Hendrik HeiBelmann, Michael Schwarz,
Jannik Schottler, Lena Vorspel,
Ingrid Neunaber, Lars Kröger,
Elias Modrakowski, Johannes Krauß,
Joachim Peinke, Michael Hölling

Project partners:
Energy Research Centre of the Netherlands, ECN (Netherlands, coordinator)
Delft University of Technology, TU Delft (Netherlands)
Technical University of Denmark, DTU (Denmark)
Fraunhofer IWES (Germany)
University of Oldenburg, ForWind (Germany)
University of Stuttgart (Germany)
National Renewable Energy Centre, CENER (Spain)
University of Glasgow (UK) (Until September 1st 2015: University of Liverpool)
Centre for Renewable Energy Sources and Saving, CRES (Greece)
National Technical University of Athens, NTUA (Greece)
Politecnico di Milano, Polimi (Italy)
General Electric, GE (Germany)
LM Wind Power (Denmark)

Funding: European Union's Seventh Programme for research, technological development and demonstration

Ref.Nr. FP7-ENERGY-2013-1/no. 608396

Duration: 01/11/2013 – 31/12/2017

Introduction

Modern wind turbines are constantly increasing in size, i.e. rated power, rotor diameter, hub height etc. and with the increasing size comes the challenges of the structural and aerodynamic scaling laws. The so-called square-cube relationship between size and weight of the turbine rotors requires the manufacturers and designers to introduce thinner and thus more flexible rotor blades in order to be able to increase the rotor diameter of future wind turbines. This holds in particular for offshore applications. However, the design of lighter and more flexible rotors introduces not only challenges to the material selection and the manufacturing, but also challenges the design tools used today. The aerodynamic design process of wind turbines is heavily relying on fast engineering tools based on blade element momentum theory (BEM) or free vortex models. These so-called low-fidelity models are preferred over high-fidelity computational fluid dynamics (CFD) codes, which resolve the local aerodynamics of wind turbines, due to their significantly lower computational costs. However, these engineering models are validated for today's wind turbines, but as future wind turbines grow in size, the models are used well out of their validated range.

Within the EU funded AVATAR project, the consortium of 11 research institutes and two industry partners focused on the improvement and validation of aerodynamic modeling tools for large wind turbines, i.e. larger than 10 MW.

Project Description

AVATAR was set to validate different engineering tools for aerodynamic calculations of future 10+MW wind turbines against both, high-fidelity CFD simulations and dedicated measurements of the aerodynamic coefficients of airfoil profiles. ForWind contributed to several numerical and experimental tasks of the project.

The impact of turbulent inflow conditions on the aerodynamic performance of an DU00-W-212 airfoil profile was investigated based on data from wind tunnel campaigns at 1 Million Reynolds number. These measurements with turbulent inflow at comparably low Reynolds numbers were complemented by standard measurements in laminar inflow conditions at the design Reynolds numbers of the airfoil as well as high Reynolds number measurements in a pressurized wind tunnel [3]. However, both of these campaigns were not able to account for the effects of turbulent inflow on the airfoil aerodynamics.

To investigate the impact of inflow turbulence on the aerodynamic performance, representative flow patterns were selected based on field measurements and scaled to match the dimensions of the wind tunnel model. These tailored inflow conditions comprised periodic and extreme fluctuations of the angle of attack as well as different reproductions of measured inflow angle time series. A sophisticated control pattern of the active grid was therefore used, allowing for the repeated reproduction of the turbulent and unsteady inflow time series in multiple experimental cases [2].

High-resolution force measurements and pressure scans along the airfoil chord were taken for a total of 28 inflow cases. Along with the setup specifications, time series of the inflow and derived characteristic aerodynamic quantities, like lift, drag and

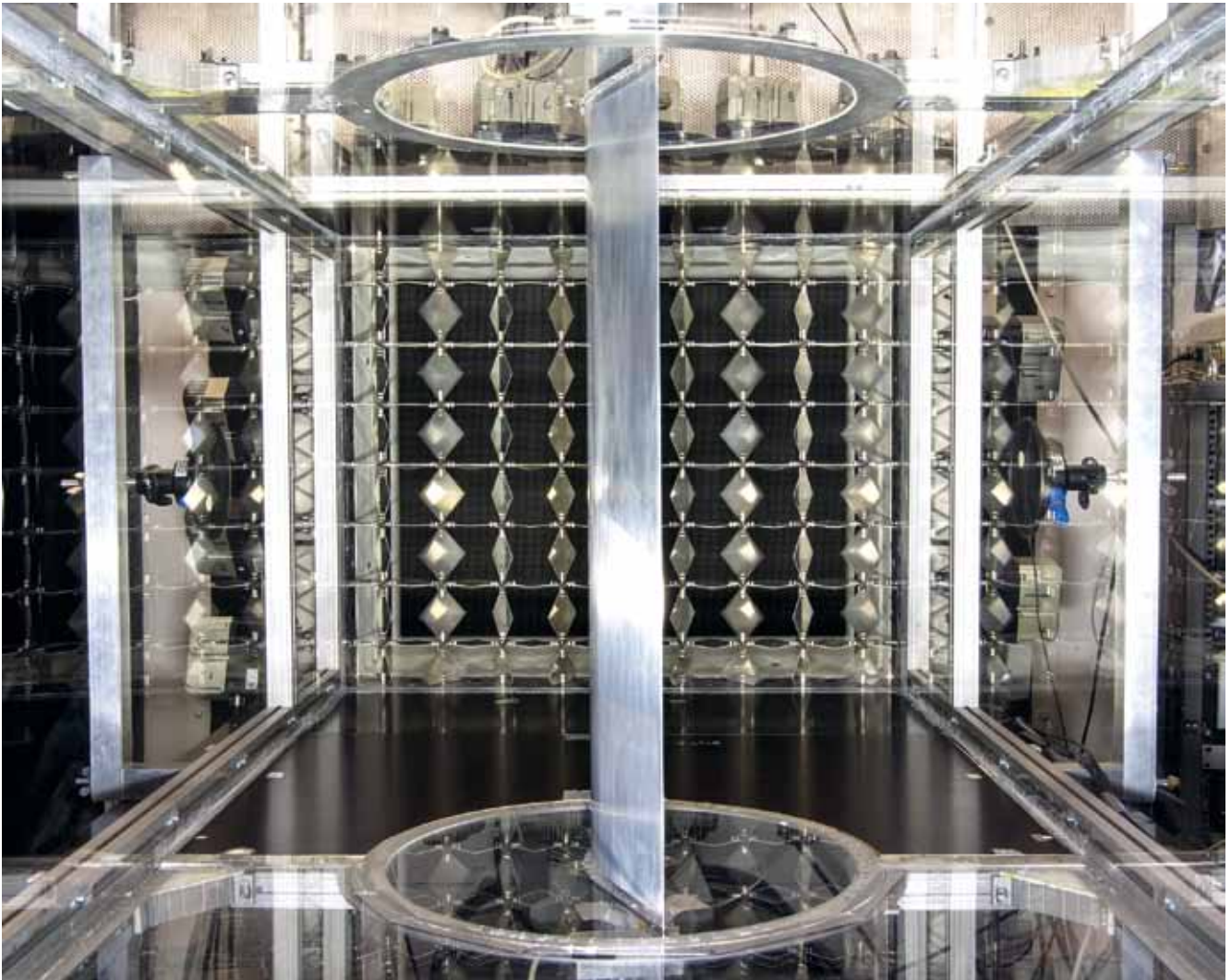

Figure 1: Upstream view of the wind tunnel test section with mounted active grid in the back and DU00-W-212 airfoil profile in the center

momentum coefficients, were provided to validate the CFD simulations with inflow turbulence. Although, reasonable agreement between the simulations and the experiments were found in a lot of cases, some deviations underline the challenges of both, the comprehensive measurement of flow fields and aerodynamic quantities as well as the integration of the measured flow properties in computational methods [4]. Thus, a significant demand for further research on these methods was identified.

Besides the validation data from wind tunnel experiments, ForWind contributed com-

putational studies regarding the impact of geometrical rotor parameters on the performance and loads in the context of upscaling as well as the impact of turbulence intermittency. For the first investigation, the AVATAR reference wind turbine (RWT) was subject to slight modifications of the blade thickness at the outer rotor regions. Airfoil thickness was increased by 2% and CFD simulations of the altered profiles were used to derive the airfoil coefficients. These were included in power curved calculations and estimations of several characteristic turbine loads by means of engineering BEM tools. A comparison of results from several state-

of-the-art codes showed reasonable agreement between the codes [5]. The effects of thicker airfoils were found to be in the same order of magnitude like effects of increased Reynolds number, both of which are relevant for the upscaling of the current turbine designs towards 20MW.

Similar methodology was used to study the effect rotor solidity with the purpose to investigate the loading on upscaled wind turbines with different induction. Results suggest, that low induction rotors with slender blades are preferred for these cases.

No exceptional or unexpected aero-elastic behavior was found in both cases, but results should not be generalized and need further validation.

Further simulation activities were dedicated to assessing the impact of the included wind fields on the turbine performance derived from two different engineering tools (BEM). While engineering tools usually rely on wind fields with normal distributed velocity changes, atmospheric measurements typically show a higher probability for large wind speed changes – so-called intermittency. Both used BEM codes were found to process the generated normal-distributed and intermittent wind fields in a similar way, which is essential to allow for a code-to-code comparison of actual wind turbine loads. While rotation speeds of the turbine showed intermittent behavior in data from both tools, the assessment of fatigue loads for a limited set of damage equivalent load cases (DEL) returned mixed results. While one code indicated a high sensitivity of DEL to intermittent inflow, the other code showed a lesser impact on the loads, which emphasizes the need for further studies and code-to-code comparisons in this regard [6]. However, it is apparent, that turbulence intermittency can be a potent influence on the damage equivalent loads, which needs further investigation.

Summary

The AVATAR project consortium of 11 scientific institutions and two industry partners made substantial efforts to compare and validate different design tools for future large wind turbines. Validations were based on wind tunnel measurements of airfoil characteristics in a wide range of Reynolds numbers and in turbulent conditions. Moreover, comparisons to field measurements and high-fidelity CFD simulations provided valuable insights on the validity of state-of-the-art engineering tools for aero-elastic wind turbine simulations as well as their shortcomings.

The validation data and test cases have been made publicly available and detailed project results are published in scientific articles and deliverable reports – all which are available on the project website [1]. A summary of some key project findings will be presented at the TORQUE conference 2018.

References

- [1] www.eera-avatar.de
- [2] Heißelmann, H.; Peinke, J.; Hölling, M.: Experimental Airfoil Characterization under Tailored Turbulent Conditions, *J. Phys.: Conf. Ser.* 753 072020, (2016)
- [3] Ceyhan, O.; Pires, O.; Munduate, X.; Sørensen, N.N.; Schaffarczyk, A.P.; Reichstein, T.; Diakakis, K.; Papadakis, G.; Daniele, E.; Schwarz, M.; T. Lutz, T.; Prieto, R.: Summary of the Blind Test Campaign to predict the High Reynolds number performance of DU00-W-210 airfoil, 35th Wind Energy Symposium, AIAA SciTech Forum, (AIAA 2017-0915)
- [4] Kim, Y.; Lutz, T.; Jost, E.; Gomez-Irardi, S.; Muñoz, A.; Méndez, B.; Lampropoulos, N.; Stefanatos, N.; Sørensen, N.N.; Madsen, H. Aa.; van der Laan, P.; Heißelmann, H.; Voutsinas, S.; Papadakis, G.: AVATAR Deliverable 2.5: Effects of inflow turbulence on large wind turbines, project deliverable, (2016)
- [5] Schwarz, C. M.; Aparicio-Sanchez, M.; Astrain Juangarcía, D.; Gonzalez-Salcedo, A.; Ramos García, N.; Sessarego, M.; Sørensen, N.N.; Schramm, M.; Thomas, P.; Chasapogiannis, P.; Chaviaropoulos, T.; Manolesos, M.; Sieros, G.: D4.10: Effect of blade solidity and thickness on performance and loads, project deliverable, (2017)
- [6] Schwarz, C. M.; Ehrich, S.; Thomas, P.: D 4.7 Turbulence Intermittency, project deliverable, (2016)

Hybrid Laminates and Nanoparticle Reinforced Materials for Improved Rotor Blade Structures (LENAH)

Leibniz Universität Hannover
Institute of Structural Analysis

Raimund Rolfes, Behrouz Arash,
Christian Gerendt, Robin Unger

Funding: Federal Ministry of Education
and Research

Ref. Nr. 03SF0529

Duration: 09/2015 - 07/2019

Introduction

In order to perform the energy transformation both successfully and economically, the efficiency of energy generation from renewable sources must be further increased. With regard to wind energy, this means increasing the energy yield per turbine, which is usually achieved by an increase of the rotor diameter. However, the rotor blades are exposed to several loads due to wind and turbulences, the inertia of the blade during rotation and others, leading to gradual fatigue of the blade material. With higher material strengths, less material is needed to make the blade resistant to a given load, or to push boundaries further when it comes to the design of lightweight blades with simultaneous increase of the blade length. The aim of the LENAH research project is therefore to develop material systems that lead to a longer service life and improved lightweight construction for wind turbines. The scientists are working on improvements throughout the entire process chain – from material development to component design.

Project Description

Although today's rotor blades of wind turbines can hold lengths larger than 85m, conventional materials are increasingly reach-

ing their performance limits when it comes to achieving a longer service life and better exploitation of the lightweight construction potential. One of the main problems concerning offshore rotor blades is the blade stiffness, which needs to be increased with increasing length. A large blade of inappropriately low stiffness may contact the tower under extreme loading conditions. A total loss of the turbine would be the result. Ensuring sufficient stiffness of future blades with today's established materials would either lead to higher weights in case of glass fiber reinforced polymers (GFRP) or to unacceptable high costs in case of carbon fiber reinforced polymers (CFRP). An additional issue is the high fatigue resistance of the applied material, which is required to withstand up to 10^7 (100 million) load cycles during the wind turbine's lifetime of about 20 years. If the fatigue resistance of the materials applied is too low, cracks may grow within the blade, yielding its total loss at worst. The fact that future blades with lengths over 90 m will have to withstand fatigue loadings of even higher amplitudes than today's largest blades motivates the urgent need for materials with a high fatigue resistance. The application of traditional materials like GFRP or CFRP would again yield too heavy and too cost-intensive constructions. Within the LENAH project, innovative material concepts are to be investigated, which offer such improved fatigue characteristics. The scientists are working on improvements throughout the entire process chain – from material development to component design. To do so, the project takes into account two important fields of material research: The development of nanoparticle-modified plastics to increase service life and hybrid materials to optimize lightweight construction.

For the research topic "nanoparticle modification", researchers are specifically changing the material properties of materials through the use of nanoparticles. The aim is

to use nanoparticle-modified materials in the whole rotor blade and to substitute the usual resin system. This can improve the mechanical properties of fiber-reinforced laminates and adhesives, which in turn improves the strength and behavior of the rotor blade under different wind conditions. Nanomodified polymers are created by mixing nanoparticles with an average size of about 20 nm ($20 \cdot 10^{-9}$ m) and conventional polymers. The interaction between the polymer molecules and the nanoparticles, which have a huge cumulative surface ('nano effect'), lead to improved mechanical properties of the material. This beneficial effect can be applied for fiber reinforced polymers, as well as for pure adhesive polymers. Within the LENAH project, nanoparticle reinforced polymers are investigated by experimental tests and multi-scale finite element simulations. First of all, atomistic simulations on the nano scale are performed to derive the unknown material properties, followed by micro-scale simulations as well as component simulations on the macro scale (see Fig. 1). The major aim is to understand and characterize the influence of nanomodifications on the material properties. With the knowledge gained, materials can be designed that merge the positive characteristics of the base materials and allow a more efficient design of wind turbine rotor blades.

In contrast, hybrid laminates are used locally in particularly stressed areas in order to provide a sufficient fatigue resistance. Hybrid materials, which combine different materials to profit from their individual benefits, are playing an increasingly important role in industrial applications. Within the LENAH project, hybrid laminates made from GFRP and stainless steel as well as GFRP and CFRP will be investigated concerning their applicability in highly stressed areas of wind turbine rotor blades. Here, not only the optimization of the resulting material properties is considered, but also the manufacturability and the profitability.

GFRP-steel laminates are to be used within the load introduction area, where the blade is bolted to the hub of the turbine. Due to the bolt holes, local stress concentrations occur, which can damage the rather brittle GFRP significantly. Local implementation of ductile steel foils in between the GFRP plies yields a smooth introduction of the loads from the bolts into the laminate on the one hand, and increases the effective joint strength under static and cyclic loading conditions. Once a certain distance from the introduction area is ensured, the metal foils are substituted by regular GFRP layers. The application of GFRP-CFRP laminates is an efficient method to locally increase the

stiffness of the blade's supporting structure in areas of high loading and increased lightweight requirements (e.g. midsection of the blade). The CFRP/GFRP hybrid laminates can be used either directly to stiffen the blade or are implicitly necessary, when a pure GFRP area has to be transformed into a pure CFRP area (and vice versa) using well-designed ply substitution techniques. The investigation of hybrid laminates includes the development of computational design tools and experimental investigations.

Both technology approaches will range from basic material developments to component testing. In a first step, material systems will

be developed for the production of coupon and small component elements to basically characterize the material's benefits. Afterwards, promising materials will be further investigated at the structural level using more complex component tests. In parallel, computational tools will be developed to predict the (failure) behavior of the developed material systems. The project follows a holistic approach that does not only focus on improved characteristic material properties, but rather aims at an understanding of the mechanisms of action and the generally valid interrelationships. In a final step, the project partners collect, summarize and categorize all the results with regard to their usability, cost-effectiveness and the requirements of the wind energy industry.

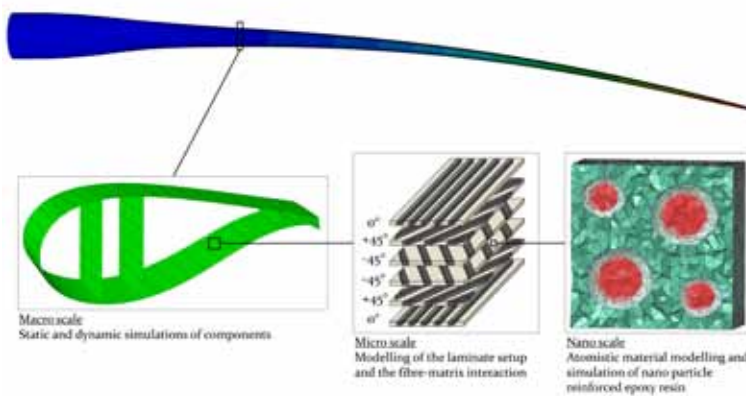

Figure 1: Schematic diagram of the multi-scale finite element approach that is followed in the research topic "Nanoparticle Modification".

Summary

The aim of the project LENA (Hybrid laminates and nanoparticle reinforced materials for improved rotor blade structures) is to develop innovative material systems for rotor blade lightweight construction and to understand their mechanisms of action. The project focuses on two different material systems: nanoparticle modified epoxy resins and hybrid laminates.

The project findings will not only contribute to an implementation of further material improvements in the future, but the knowledge gained can also be used as a basis for the development of other material systems. Improved material properties through nanoparticle modification, modified design through hybrid materials, and lightweight construction optimization are the focus not only in wind energy technology but also in other sectors, such as aerospace technology.

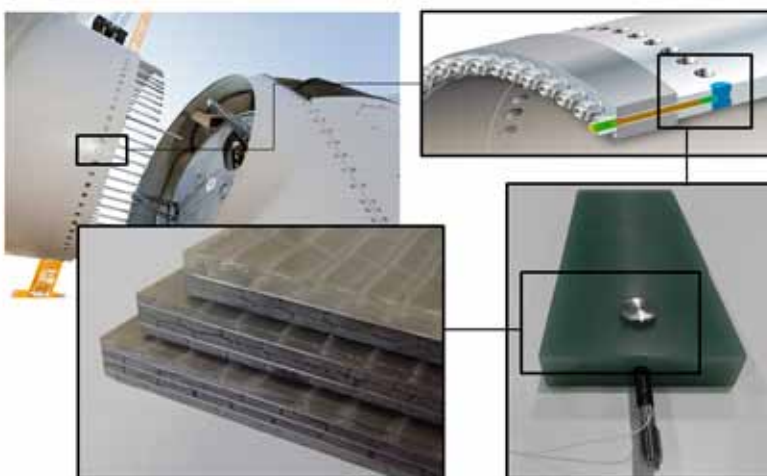

Figure 2: Schematic illustration explaining the blade root strengthening via Fiber Metal Laminates investigated in the LENA project.

Wind Turbine Load Control under Realistic Turbulent In-Flow Conditions

Carl von Ossietzky Universität Oldenburg
 Institute of Physics
 Research Group: Turbulence, Wind Energy and Stochastics (TWiSt)

Tom Wester, Michael Hölling,
 Joachim Peinke

Partners:
 Technical University Berlin
 RWTH Aachen
 University of Stuttgart
 Technical University Darmstadt

Funding: German Research Foundation, (DFG)

Ref.Nr. PE 478/15-1.

Duration: 12/2015 – 04/2019

Introduction

The atmospheric boundary layer (ABL), in which wind energy converters (WEC) operate, contains a broad spectrum of inflow fluctuations. Mainly manifesting as gusts, such inflow fluctuations cause heavy load variations for the turbine rotor. To expand the lifetime of a WEC, the load fluctuations need to be reduced. To be able to do so it is essential to understand the aerodynamic reaction of rotor blades under tailored turbulent inflow conditions. Besides generating a 2D tailored inflow, the project aim is to identify aerodynamic extreme events and link them to the aerodynamic response of an airfoil. The airfoil is equipped with an adaptive camber mechanism for load mitigation. This mechanism was already presented for static measurements in [1] with promising results. Those results will be extended to dynamic and turbulent inflows.

Project Description

The PAK780 Project, or "Wind Turbine Load Control under Realistic Turbulent In-Flow Conditions", is aimed to investigate passive smart devices which are able to minimize extreme load events and fatigue loads of WEC by influencing the aerodynamics locally at the rotor blade.

To investigate those occurring load events it is necessary to generate repeatable inflow conditions. Therefore, an active grid (shown in fig. 1) should be used. During

PIV measurements periodic structures along the shafts of the active grid (shown in fig. 2) were identified. The structures can directly be linked to the shape of the active grid flaps. To guarantee a homogeneous inflow along the spanwise direction of the airfoil it was necessary to revise the grid. This led to the new 2D active grid, which is shown in fig. 3.

The diamond shaped flaps were removed as well as all horizontal shafts leading to a grid with nine vertical shafts. Each shaft is again controlled individually by a stepper

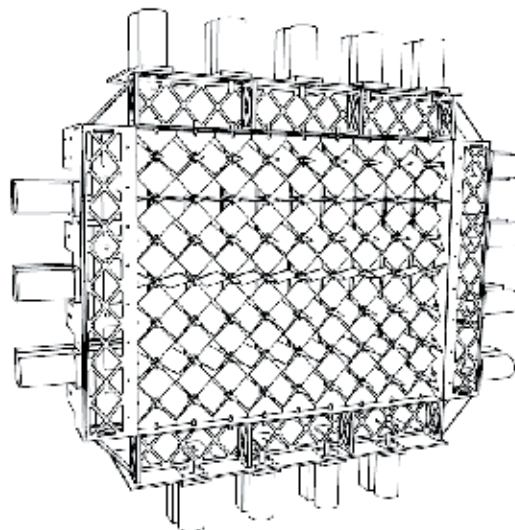

Figure 1: Active Grid which was used to generate repeatable turbulent inflows

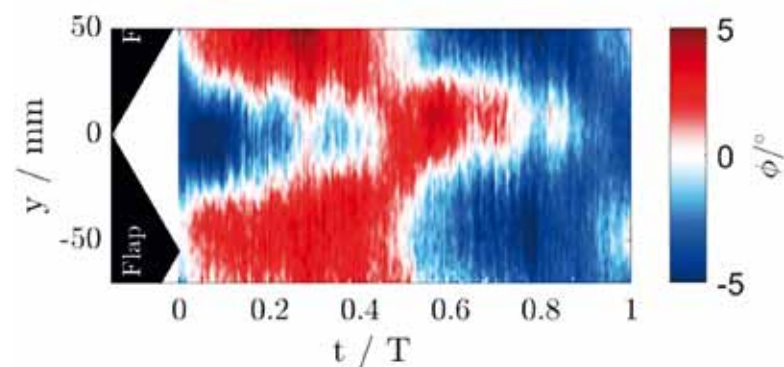

Figure 2: Generated angle of attack variations by the active grid due to flap shape

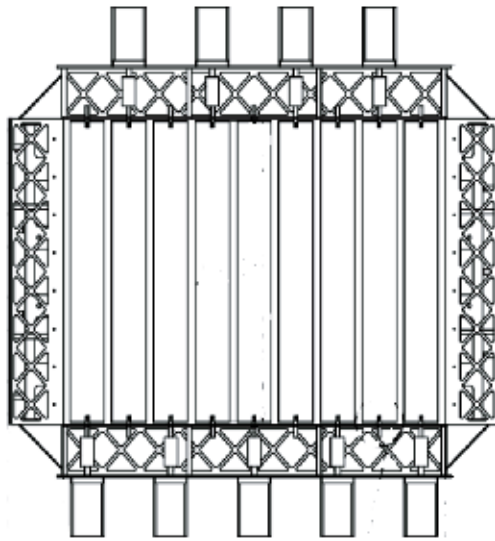

Figure 3: New designed 2D active grid with nine vertical, individual movable shaft

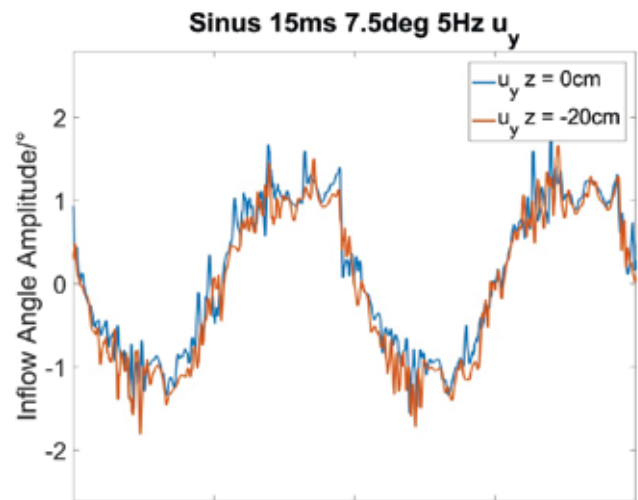

Figure 4: Periodic inflow at different spanwise positions of the new 2D active grid measured with hot wire

motor. With this a purely 2D inflow can be produced in the spanwise direction of the airfoil. This is shown in fig. 4, where the flow is measured at two different spanwise positions. Both measurements are perfectly aligned and the phase shift which was measured beforehand cannot be found anymore.

After improving the inflow for airfoil experiments, the next step was the further investigation of the adaptive camber profile (ACP) under dynamic inflow. The used setup is shown in fig. 5.

The setup includes besides the active grid to generate the inflow also force balances to measure the lift, drag and torque and a high-speed stereoscopic PIV system to measure the flow around the airfoil. This enables the simultaneous measurement of the aerodynamic response of the airfoil and the resulting forces. By this the ACP can be directly compared to the baseline case and the differences under turbulent inflow for both airfoils can be identified.

First measurements of the ACP under periodic sinusoidal inflow show a significant

reduction of lift fluctuation and additional an increase in mean lift generated by the airfoil. This is shown in figure 6, where the lift coefficient for both airfoils is plotted for a sinusoidal inflow of 8Hz at a mean angle of attack of 10°. The red curve represents the baseline airfoil and blue the ACP. From the plot a reduction of minimum and maximum for the ACP can be observed, leading to a decrease of lift fluctuations by 29%. Furthermore, the mean lift could be increased by 12% compared to the baseline Clark-Y airfoil.

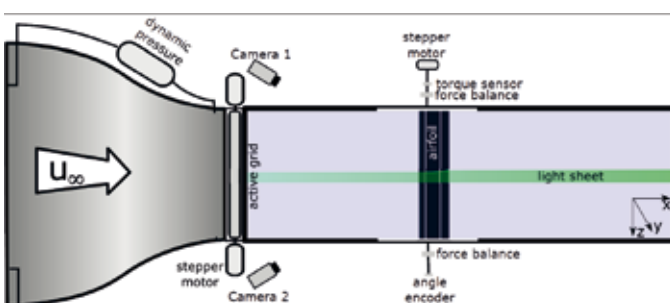

Figure 5: Wind tunnel setup to measure the flow field around the ACP under 2D inflow conditions

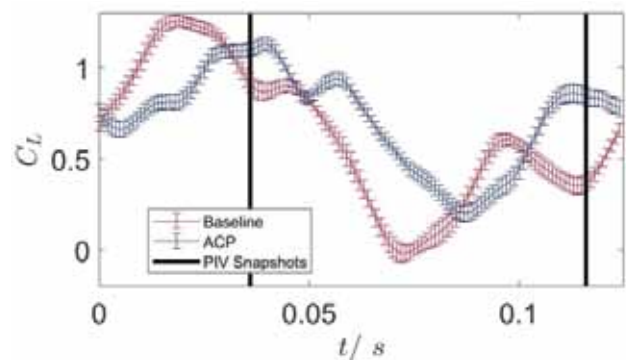

Figure 6: Comparison of generated lift of the baseline airfoil in red and the ACP in blue. The data are phase averages, where the error bars represent the standard deviation. The black vertical lines represent the time of the PIV snapshots

One of the reasons for this can be seen in figure 7. The figure shows PIV snapshots of the flow around both airfoils. The upper line shows the response of the airfoils to a big angle of attack. Whereas the baseline airfoil shows a rather large separation with an early separation point, the ACP reduces the separation area due to the upwards deflection of the trailing edge flap. Also, the point of separation is mitigated further downstream

on the chord. By this the abrupt loss of lift, which is seen for the baseline airfoil, is reduced for the ACP. The second line shows compared to this a rather small AoA. In this case the ACP cambers, leading to a higher flow velocity around the airfoil and by this a higher lift is generated. This leads to an increase of the minimal lift compared to the not cambering baseline airfoil.

Summary

Within the project “Wind Turbine Load Control under Realistic Turbulent In-Flow Conditions”, a method to generate defined turbulent 2D inflow fields in a wind tunnel was developed. With given periodic inflow fields it was possible to connect these with the aerodynamic response of the airfoil. For this purpose, the loads had been measured simultaneously with the flow field, which was measured by means of high-speed stereoscopic Particle Image Velocimetry. By comparing the baseline airfoil with the adaptive camber airfoil, it was possible to identify significant differences in the aerodynamics of both airfoil types.

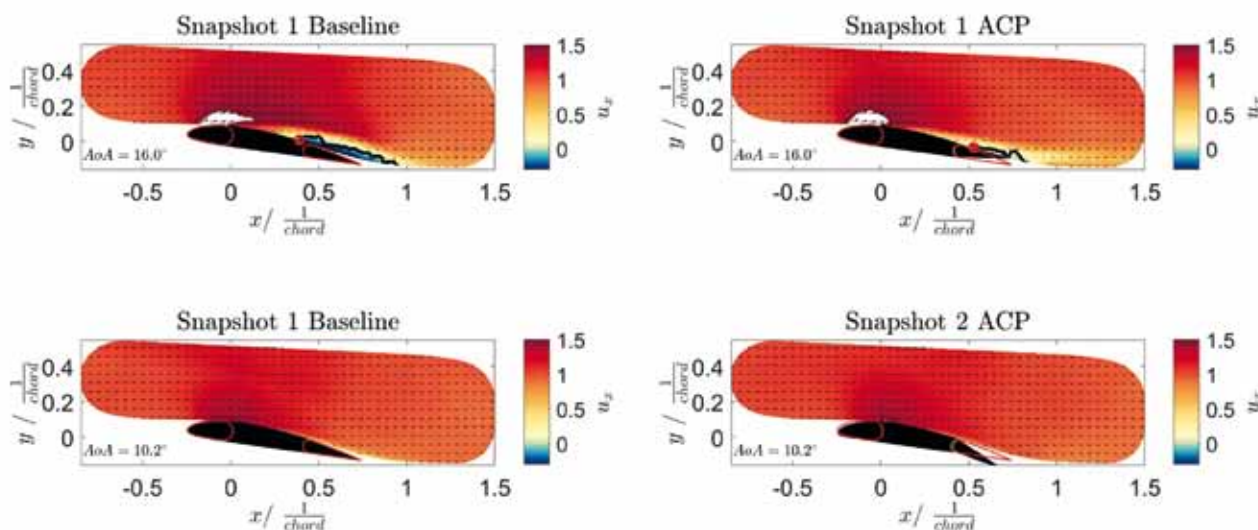

Figure 7: PIV measurements of the baseline airfoil (left) and the ACP (right). The upper line represents the time of the first black line, the lower one the second.

References

- [1] Lambie B.: Aeroelastic investigation of a wind turbine airfoil with self-adaptive camber, Ph.D. thesis, Technische Universität Darmstadt (2011)

Smart Blades – Development and Design of Intelligent Rotor Blades

Carl von Ossietzky Universität Oldenburg
Institute of Physics
Research Group: Wind Energy Systems
Research Group: Turbulence, Wind Energy and Stochastics

Hauke Beck, Martin Bitter, Bastian Dose, Agnieszka Hölling, Tim Homeyer, Michael Hölling, Martin Kraft, Martin Kühn, Joachim Peinke, Francesco Perrone, Hamid Rahimi, Marijn van Dooren, Lena Vorspel, Róbert Ungurán, Mehdi Vali

Leibniz Universität Hannover
Institute of Structural Analysis,
Institute of Turbomachinery and Fluid Dynamics,
Institute for Wind Energy Systems

Majeed Bishara, Mehdi Garmabi, Eelco Jansen, Raimund Rolfes, Carl Robert Brand, Benedikt Ernst, Jörg Seume, Torben Wolff, Claudio Balzani, Moritz Bätge, Johannes Ende, Daria Horte, Jaione Ortega Gómez, Andreas Reuter, Alper Sevinc

Funding: Federal Ministry for Economic Affairs and Energy (BMWi)

Ref.Nr. 0325601C (Hannover)
0325601D (Oldenburg)

Duration: 12/2012 – 02/2016

Introduction

Modern wind energy converters are increasing in size. At the same time, loads acting on the rotor blades and the subsequent components become more and more problematic, for both blade design and operation. Within the Smart Blades project, different technologies have been considered that aim for a reduction of aerodynamic loads and their fluctuations. In close cooperation with the German Aerospace Center (DLR) and

the Fraunhofer Institute for Wind Energy and Energy System Technology (IWES), ForWind has participated with its wide variety of expertise in each part of the project, which is organized in four technologies.

Project Description

Technology 1 – Passive Smart Blades with bend-twist coupling

The focus of Technology 1 was the investigation and design of wind turbine blades which feature bend-twist coupling as a passive load control mechanism to reduce the aerodynamic loads.

ForWind Oldenburg was in charge of tasks that deal with the development of new numerical simulation tools and controller concepts. The simulations included an automated optimization of complete rotor blades with respect to their aerodynamics [1]. The resulting code allows for variable implementation of bend-twist coupling at different regions of the blade and the separation from pure bending, pure twisting and bend-twist coupled blades. A tool chain has been developed that allows automated grid generation for 2D profiles and the complete rotor [2]. With this a detailed investigation for wind turbines under the condition of yaw-misalignment has been performed which led to an implementation of a correction in the BEM based tool FAST. Additionally, a new solver for fluid structure interaction (FSI) has been developed to account for changes in the resulting aerodynamics while flexible blades move in the flow due to acting forces. After verifying of the new solver it has been applied to the reference blade of this project. In the field of controller concepts a model of the reference and the bend-twist coupled blades have been used to find optimal control strategies with state-of-the-art Collective Pitch Controller (CPC) as well as with Single Input Single Output (SISO) and Multi Input Multi Output (MIMO) In-

dividual Pitch controllers (IPC). The results showed a significant reduction of the fatigue loads in the rotor blades as well as the support structure. The best results were found for the bend-twist coupled blades combined with MIMO IPC.

ForWind Hannover investigated the load-reduction potential of geometrical bend-twist coupling, i. e. the inclusion of a pre-sweep in the rotor plane towards the trailing edge. The impact of the shape of the sweep function on the reduction of fatigue and extreme loads with respect to the reference turbine was the target outcome. A detailed parameter study for the optimization of the sweep function has been carried out [3] revealing a substantial reduction of the fluctuation of aerodynamic loads [4]. This led to a significant reduction of fatigue and extreme loads in the rotor blades and the support structure. The flutter limit of the swept blade was analyzed in the frequency and the time domain using HAWCStab2 and HAWC2. Analytical models were developed and parameter and sensitivity studies executed. The flutter limit increased for swept blades compared with the reference blade. A demonstration rotor blade with a length of 20m with geometrical bend-twist coupling has been designed, see Fig. 1, and provided to DLR for manufacturing and field testing in a follow-up project. In order to support the analytical and numerical studies, material and component tests have been carried out in strong cooperation with Fraunhofer IWES. Material tests under multi-axial fatigue loading and structural tests on thick laminates and scaled blade root bolt connections were carried out. A deeper understanding of the structural performance of passive smart blades could be extracted from the experimental work.

Technology 2 – Smart Blades with active trailing edge

Technology 2 dealt with the development of smart rotor blades with trailing edge flaps and actively deformable trailing edges.

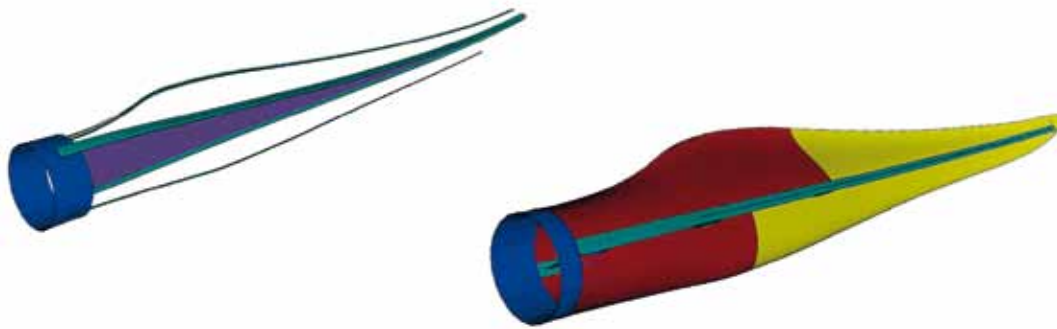

Figure 1: Blade design of the 20 m demonstration blade. (a) Primary blade structure with central shear web; (b) Blade structure with sandwich panels (pictures from [5]).

These are typically applied in the outer part of the rotor blade to reduce the loads acting on the wind turbine.

Focus of ForWind Oldenburg was in the research of optimal control strategies with the aim to reduce particularly higher harmonic loads. First relevant sensors have been iden-

tified which can measure the wind speed in front of the rotor. A continuous-wave (cw) Laser Detection and Ranging System (LiDAR) has been purchased and used to characterise the incoming wind field in temporal and spatial resolution with approx. 400 measures points/sec with $\pm 30^\circ$ inclination angle and a focus length of 10 to 150 m.

Various combinations of active trailing edge flaps with individual pitch control to reduce the 1P or 2P Loads on the blade root were examined with help of the aeroelastic simulation tool HAWC2. The most suitable strategy for a robust multi-variable controller (MIMO) was the H-infinity controller (H_∞). Furthermore, an “anti-wind-up” system was implemented around the saturation in the actuator balancing loop. It has been shown, that the maximum lifetime fatigue load reduction could be achieved with a combination of individual pitch and trailing edge flap control, see Fig. 2. The reduction of the 2P flapwise bending moments via the trailing edge flaps lead to load reduction on other components of the turbine as well.

The suitability of the tool chain that has been developed for Technology 1 has been proven for active trailing edge flaps as well. This includes automated meshing and 2D-CFD simulations, translation of 2D-polar in FAST-Simulation environment as well as run-time evaluation of 3D-CFD rotor simulations. Needed correction models for the inclined flow for FAST simulations have been developed as well.

ForWind Hannover was in charge of tasks considering structural, aerodynamic, and aeroacoustic aspects. A representative finite element discretization using shell elements was chosen as a basis for fatigue, strength, and vibration analyses at blade level. To facilitate the structural modeling and analysis activities, an input generator for the finite element program ABAQUS was developed. Specific strength analyses have been carried

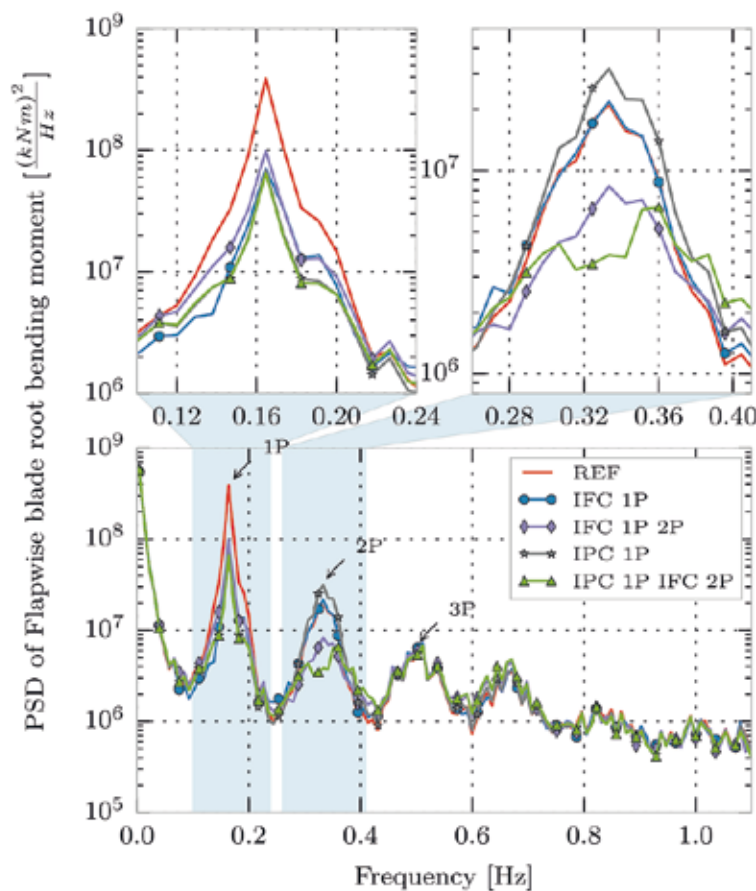

Figure 2: Power spectral density of the flapwise blade root bending moments at 13 m/s for different control combinations (pictures from [6])

out for the flexible trailing edge. Moreover, in the context of strength modeling, a novel hybrid micro-meso modeling approach has been developed for the simulation of progressive failure considering the interaction between fiber kinking, splitting, matrix cracking, and delamination. For aerodynamic considerations, a BEM-based unsteady aerodynamic model was implemented in Matlab that captures the dynamics of pitch and flap motions. Pitch, flap and combined pitch/flap motions have been simulated. Unsteady 2D CFD simulations have been carried out as well. The BEM- and CFD-based simulation results were compared and showed generally good agreement. From the CFD results, unsteady characteristics could be extracted, which have been used for the derivation of a novel empirical aerodynamic model. Critical load and simulation cases have been extracted for fixed flap angles, i. e. flap actuator fault situations, in order to prepare activities on the determination of flutter limits in a follow-up project. In order to characterize the aero-acoustic behavior of trailing edge flaps, wind tunnel experiments have been carried out. After designing and manufacturing of a test specimen preliminary studies were executed in Hannover for the development and design of aerodynamic and acoustic measurement systems and the respective evaluation algorithms (beamforming). An exten-

sive measurement campaign was conducted in the aero-acoustic wind tunnel at the DLR in Braunschweig, see [7]. CFD simulations were compared with the experimental data so that a model for the noise emission as a function of the angle of attack and the flap angle could be extracted.

Technology 3 – Active slat

Along with the design of the slat done by the DLR, wind tunnel tests have been performed in the wind tunnel in Oldenburg [9]. For the characterization of the effect of different positions (Hub) of the trailing edge of the active slat, standard polar measurements have been performed with combinations of mean angle of attack of the profile and hub position of the slat. Fig. 4 influence of slat. shows that the lift coefficient changes for different settings. This was used to design an experiment, where an active grid was used to generate angle of attack variations over time at the leading edge of the profile. This inflow resulted in a sinusoidal change in the angle of attack of 5Hz and about 4° amplitude. The Hub movement of the active slat was also operated at the maximum Hub amplitude. Triggered measurement allowed for different time shifts between the start of the active grid motion and the slat motion. Fig. 5 active slat effect shows the measured standard deviation of the lift coefficient over the resulting phase

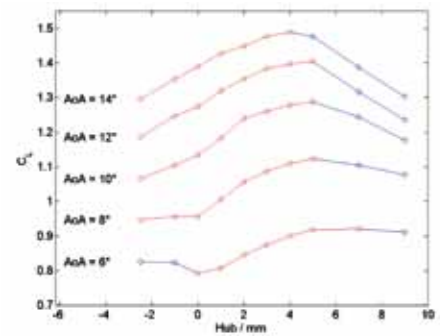

Figure 4: Lift coefficient for different mean angle of attacks of the profile over trailing edge positions (Hub) of the active slat.

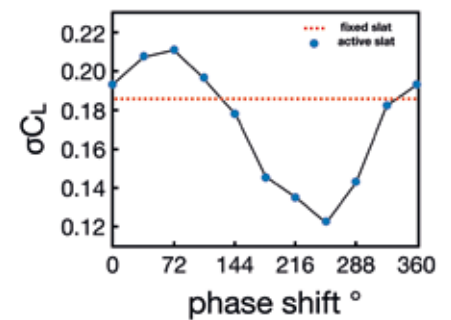

Fig. 5: Standard deviation of the measured lift coefficient for different phase shifts between the motion of the slat and the incoming flow with changing angles of attack. The profile was set to a mean angle of attack of 10°. The red dotted line represent the measured standard deviation for identical inflow conditions but the fixed slat.

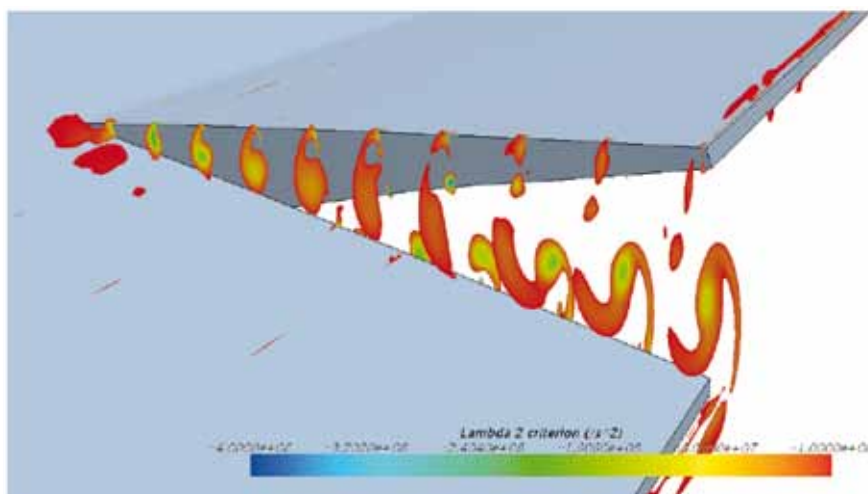

Figure 3: CFD simulation showing a vortex at the side edge of the trailing edge flap resulting in noise (view on the suction side; flap deflection of 15°; angle of attack of 6°; picture from [8])

shift between the active grid motion and the slat motion. The red dotted line represents the standard deviation for the slat in a fixed position. It can be seen that the active slat technology is able to change the aerodynamic response of the complete profile even at a frequency of 5Hz. The final result of the experimental investigation shows that the active slat technology is also able to reduce the standard deviation of the lift coefficient and with this the changing loads acting on the profile.

Technology 4 - Cross-Technology Topics

Activities that cannot be linked to one single of the investigated technologies were integrated in the cross-technology topics. The

core goal was the evaluation of the different smart blades technologies.

Fraunhofer IWES together with ForWind Hannover finalized the 3D design of a reference blade as well as the specification of the reference turbine model, which both serve as a basis for the comparative evaluation of the smart blades technologies.

To estimate the risk potential for Smart Blades, ForWind Oldenburg created fault models for the reference system, Technology 1 and Technology 2. For Technology 3, a comparative evaluation of reliability was performed. The consequences of possible failures were investigated by means of simulation models. From this, design requirements and parameters in the form of sensitivity analyses for passive smart blades regarding shape and dimensional tolerance were derived. For active systems robustness and design of critical components have been analysed as well. Necessary changes to the relevant directives and standards were identified. There is only a small need for changes in the regulations. However, due to not yet performed validation, an increased partial safety factor for model uncertainties seems necessary.

ForWind Hannover finalized the formulation of a techno-economical evaluation model. Expert interviews were prepared, conducted and evaluated in order to guarantee an objective technology evaluation on a solid basis. The power curves were extracted from the loads simulations provided by Fraunhofer IWES. The corresponding annual energy yield was calculated and included in the determination of the leveled cost of energy for the different technologies.

Summary

Within the Smart Blades project, ForWind was involved in the development of new numerical simulation tools and controller and blade design concepts for Technology 1. Amongst others, fluid-structure interaction was added to the tool chain that allows aerodynamic analyses for flexible blades. In Technology 2, ForWind participated in

structural, aerodynamic, and aeroacoustic investigations regarding the concept of an active trailing edge. On the structural side, shell-type (“3D”) finite element models have been used to perform vibration, stability, strength and fatigue analyses. Wind tunnel experiments including High-Speed PIV under turbulent inflow conditions have been the basis for a better understanding of the effectiveness of slats in Technology 3. In the cross-technology topics ForWind participated in developing a 7.5 MW reference wind turbine model for loads simulation purposes and corresponding reference rotor blades including detailed lay-up specifications.

Furthermore, ForWind developed a holistic evaluation model including technological and economical aspects as well as reliability analyses for the turbine concepts under investigation.

References

- [1] Vorspel, L.; Schramm, M.; Stoevesandt, B.; Brunold, L.; Brünner, M.: A benchmark study on the efficiency of unconstrained optimization algorithms in 2D-aerodynamic shape design, *Cogent Engineering*, vol. 4, no. 1, p. 1354509 (2017)
- [2] Rahimi, H.; Daniele, E.; Stoevesandt, B.; Peinke, J.: Development and application of a grid generation tool for aerodynamic simulation of wind turbine, *Wind Engineering*, April 2016 vol. 40 no. 2 pp. 148-172
- [3] Sevinc, A.; Bleich, O.; Balzani, C.; Reuter, A.: Parameterized analysis of swept blades regarding bend-twist coupling, *Proceedings of DEWEK 2015, Bremen, Deutschland*, 19.-20.07.2015.
- [4] Sevinc, A.; Bleich, O.; Balzani, C.; Reuter, A.: Aerodynamic and structural aspects of swept blades in the context of wind turbine load reduction, *Proceedings of the EWEA conference, Paris, France* (2015)
- [5] Bätge, M.: Design of a 20m blade for the demonstration turbine, *Technical Report, Deliverable No. 1.2.6.1/1.2.6.3, coordinated research project “Smart Blades”, funded by the German Federal Ministry for Economic Affairs and Energy*, Ref. No. 0325601C, Leibniz University Hannover, Institute for Wind Energy Systems (2016)
- [6] Ungurán, R.; Kühn, M.: Combined Individual Pitch and Trailing Edge Flap Control for Structural Load Alleviation of Wind Turbines, *2016 American Control Conference (ACC) 6-8 July 2016 [Piscataway, NJ] : IEEE* (2016), pp. 2307-2311
- [7] Brand, C. R.; Seume, J. R.: Flaps for wind turbine applications: Results of an acoustic study, *Proceedings of the EWEA conference, Paris, France* (2015)
- [8] Brand, C. R.: Numerische Simulation instationärer Strömung an Klappe, *Deliverable No. 2.2.8.2, coordinated research project “Smart Blades”, funded by the German Federal Ministry for Economic Affairs and Energy*, Ref. No. 0325601C, Leibniz Universität Hannover, Institute of Turbomachinery and Fluid Dynamics (2015)
- [9] Manso Jaume, A.; Wild, J.; Homeyer, T.; Hölling, M.; Peinke, J.: Design and wind tunnel testing of a leading edge slat for a wind turbine airfoil, *DEWEK 2015, Proceedings*

GigaWind *life* – Life time Research on Support Structures in the Offshore Test Site *alpha ventus*

Leibniz Universität Hannover
 Institute of Structural Analysis
 Institute of Geotechnical Engineering
 Institute of Steel Construction
 Institute for Building Materials Science
 Ludwig-Franzius-Institute for Hydraulic,
 Estuarine and Coastal Engineering
 Institute for Concrete Construction

Martin Achmus, Johannes Albiker,
 Jan Dubois, Rasmus Eichstädt,
 Jan Häfele, Joshua Henneberg,
 Ralf Herrmann, Arndt Hildebrandt,
 Mahmoud Jahjough, Sebastian Kelma,
 Ludger Lohaus, Nikolai Penner,
 Alexander Raba, Raimund Rolfes,
 Patrick Rzczkowski, Tobias Schack,
 Dominik Schäfer, Peter Schaumann,
 Alexander Schendel, Christoph Tomann

Funding: Federal Ministry for Economic
 Affairs and Energy

Ref.Nr. 0325575A

Duration: 02/2013 – 01/2018

Introduction

As a continuation of the project GIGAWIND *alpha ventus*, the GIGAWIND *life* project aims to expand the new economic design concept for supporting structures of Offshore Wind Turbines (OWT) developed in GIGAWIND *alpha ventus* with special emphasis on the operation of such converters, degradation mechanisms and interaction of supporting structures with its surrounding environment in the form of material damage to the support structure and the joints, fatigue, damage of the corrosion protection systems, and degradation of the pile bearing behavior as well as the determination of acting loads from waves and marine growth are considered.

The required damage and stress hysteresis measured by the comprehensive sensor

technology installed in the *alpha ventus* test field on the support structures using monitoring methods developed to date, enabling significant scientific findings to be gained from previous investments. Furthermore, validated methods and structural models were developed, both for local investigations as well as for the holistic design of the supporting structure of planned OWTs.

Project Description

- Objectives

The objective of this collaboration is to validate methods and structural models to enable a holistic and economical design of OWT supporting structures. To achieve this, a variety of research areas in the context of the GIGAWIND life subprojects, shown in Fig. 1, were investigated.

- Presentation of Subprojects

As part of the project "Validated Methods and Structural Models for an Integral and Economic Design of OWT Support Structures" different tasks and objectives were sought within the individual subprojects. These are briefly outlined below.

Subproject 1:

Data Management and Analysis

In this subproject, various monitoring, simulation and laboratory test data from OWT were merged into one user database. An additional goal was to develop optimized access and storage strategies for such data and a modular framework for the effective evaluation of large amounts of data.

Subproject 2:

Monitoring and Inspection

The task of this subproject was the monitoring of long-term measurements in *alpha ventus* as well as of model experiments in order to gain in-depth knowledge regarding the degradation of materials and corrosion protection systems and to validate previously developed SHM methods. Other important aspects were the identification of nonlinear effects (scour, hydrodynamic masses, damping) as well as the determination of stresses and partial safety factors in the context of new design concepts.

Subproject 3:

Degradation Models

In the context of this subproject, degradation models were developed, which enable

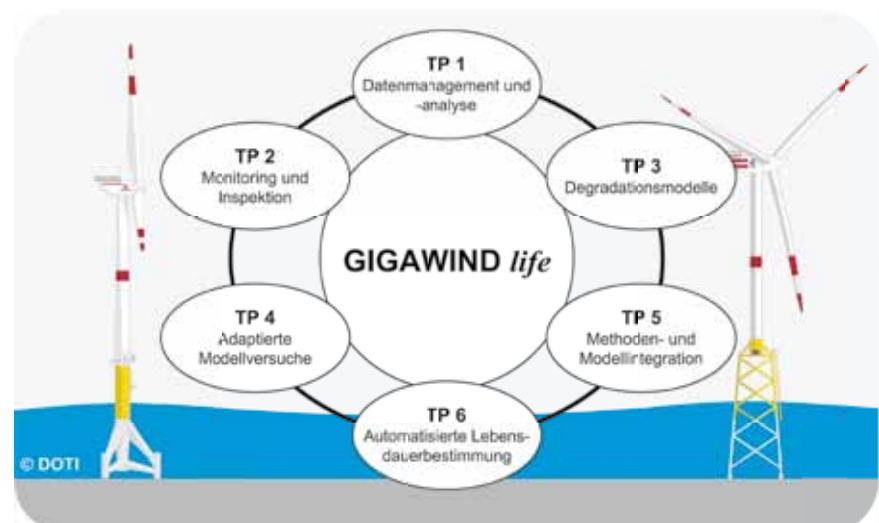

Figure 1: Structure of GIGAWIND *life*

the deduction of the influences of loads, environmental conditions and environmental factors on the lifetime of the supporting structures, providing statements about the remaining useful life of the OWT.

Subproject 4:

Adapted model experiments

Model experiments were the focus of this subproject. These should provide insights into commonly “assumed” phenomena. In addition, scour effects, structural damage and degradation of pile behavior were investigated experimentally. In addition, approaches to mineral corrosion protection are optimized.

Subproject 5:

Method and Model Integration

Within the framework of subproject 5, the integrated overall simulation using new program modules is used to provide the opportunity to map degradation processes under real load situations in order to be able to model the time-varying behavior of an OWT over its entire service life.

- State of the Art

Subproject 1:

Data Management and Analysis

A wide range of measurement options for monitoring the condition of the structure of the structure (including optic fibers and acoustic sensors) exist. With the emergence of social networks and other data-intensive applications, there has been a significant development in the area of database systems in order to be able to realize intensive research processes. The rapid discovery of semi-structured data enabled new database systems such as Apache Cassandra [1] and frameworks such as Hadoop [2]. However, existing tools for handling large amounts of data aren't readily available to Structural Health Monitoring (SHM) applications and necessary adaptations should be made.

Examples of implemented object-specific isolated solutions for data analysis in bridge structures are (see [3]):

- Arsenal Bridge, Rock Island, IL, USA, 2009
- Kishwaukee River Bridge, Illinois, USA, 2001

- Reuss Bridge in Wassen, Switzerland, 2007

At OWTs, monitoring systems on machine components represent currently the state of the art (see [4], [5]). On other components, such as the support structures, systems are increasingly used for condition monitoring, but mainly on prototypes. Accordingly, current data management and data analysis systems represent object-specific solutions. An approach to automated data evaluation exists only in the form of alarm functions, which send a notification when certain thresholds are exceeded, or in the form of SHM systems that record measured data only for the duration of such events.

Subproject 2:

Monitoring and Inspection

Previous experience in the production and load bearing behavior of grouted joints for OWTs is based predominantly on the results of small- and large-scale trials [6] and their numerical models [7]. The description of stiffness degradation of nodes under real loads cannot, however, be done due to scale effects. With the development of a prototype measuring unit in GIGAWIND *alpha ventus*, real displacements in the grouted joint could be determined for the first time. The continuous measurement of the real displacement and the associated detection of possible stiffness changes require further development.

Previous laboratory tests showed very good performance for the mineral corrosion protection system in terms of durability (see [8]). However, these are not sufficient to estimate the material degradation. The influence of defects, e.g. in the form of cracks in the mineral corrosion protection layer and their effects on the corrosion protection are not yet known for this particular application. Also, the tests according to ISO 20340 [9] for the characterization of conventional organic coatings cannot be transferred to the mineral system due to the experimental setup.

Currently, major efforts are invested throughout the world and across industries to develop effective systems for the condi-

tion monitoring of support structures (see [10], [11], [12], [13]). Investigations in [10] further summarize fundamental findings of the SHM from various disciplines into axioms. However, the use of SHM in OWTs needs some challenges to be tackled. This includes, for example, the consideration of varying operating and environmental conditions as well as a corresponding further development or adaptation of the methods and the hardware (see [14], [15], [16]). Current efforts focus on the computation of state parameters over longer time periods to better understand their variations and dependencies and translate them into probabilistic descriptions.

So far, there monitoring system enabling continuous condition monitoring of the corrosion protection system haven't been developed yet. Corrosion monitoring represents an innovative, technological concept for all technical areas, in which, despite limited accessibility, it is necessary to detect a failure of the corrosion protection system at an early stage and to initiate corrective measures in order to avoid greater damage and thus higher costs.

Subproject 3:

Degradation Models

This subproject deals with the different degradation phenomena of the supporting structures of offshore wind turbines, which have to be considered during the design process. These are the marine growth, scouring, corrosion and protection, fatigue strength of the steel components and changes in the structural behavior of soil.

The design of an offshore wind energy device considering mentioned degradation phenomena is based on state-of-the-art technology utilizing the BSH standard 7005 [17], which describes the minimum requirements for the construction-related and structural components of offshore structures for the use of offshore wind energy. In addition, DNVGL-ST-0126 [18] regulates the necessary design specifications for the supporting structures of offshore wind turbines. Within the DNVGL-ST-0126, reference is made to further DNVGL offshore standards and recommendations, which mainly deal with

the design of components of the foundation structure.

Subproject 4:

Adapted model experiments

Jian et al. [19] investigated the influence of currents with varying angles of attack and velocities in combination with waves. The relevance and influence of currents on the wave frequency, the wave rise and the forces were taken into consideration. In addition, marine growth leads to increased flow resistance due to greater surface roughness [20] and has an effect on the hydrodynamic mass of water, which influences the dynamics of the structure. In this context, detailed insights into the effects of short-sea swell, marine growth and their impact over the lifetime of OWT are still unknown.

Previous studies show high resistance of a mineral corrosion protection against frost, penetration of water and chlorides [8]. In the process, however, no overlays and previous damage of the individual test specimens are taken into account, thus are investigated within the scope of this project.

The validation of degradation models is performed based on measurement data from real turbines or experiments. Exact planning and optimization using virtual experiments is used to check the requirements and reduce costs.

Subproject 5:

Method and Model Integration

Significant developments in numerical models and tools for the holistic simulation of OWTs took place in recent years. The focus was on modeling the global behavior of the overall system. Significant detail improvements were achieved in the field of wind field, rotor aerodynamics and plant control. However, the application of more precise forecasting models has been restricted to load bearing capacity or serviceability of structural elements. With the help of numerically efficient implementations of detailed models into the overall simulation, it is possible to take account of model details and degradation effects relevant for the impact side, thus significantly improving load predictions. A new level of modeling

depth is investigated in this subproject and more accurate results about the reliability of lifetime predictions [21] will be obtained.

- Subprojects:

Subproject 1.1:

Data transfer and download

Based on extensive measured data, which were generated during the first years of operation of the offshore wind farm *alpha ventus*, validation and optimization of the structural design is carried out in the overall project. Subproject 1 evaluates the necessary data sources and creates interfaces for these data sources. In bilateral coordination with the institutes involved, it was examined which databases are relevant for the project realization and which evaluation types and algorithms are of interest. The resulting process of data management and analysis is shown in Fig. 2.

Subproject 1.3: User database

The internal data format used for data storage and data analysis in the SMMEXS soft-

ware is referred to as the DataSet format (Fig. 3). The data format describes chronologically ordered data objects, the so-called DataSets (DS). The sequence of several DataSets is called DataSetList and contains the measured data from a measuring channel or the evaluation data from an evaluation in sorted order.

Subproject 1.4:

Modular Basis for data evaluation

The software SMMEXS, which is the basis of further development within the framework of the GIGAWIND life project, can be used both for individual operation as well as for use in a client-server environment. Conceptually, the management of the measuring points and the configuration of the evaluation tasks is done by the local software SM-MEXS. The data storage of the measurement and evaluation data is performed by the software LAMA (LArge Measurements Accessible) of the project partner Fraunhofer Gesellschaft e.V. [22].

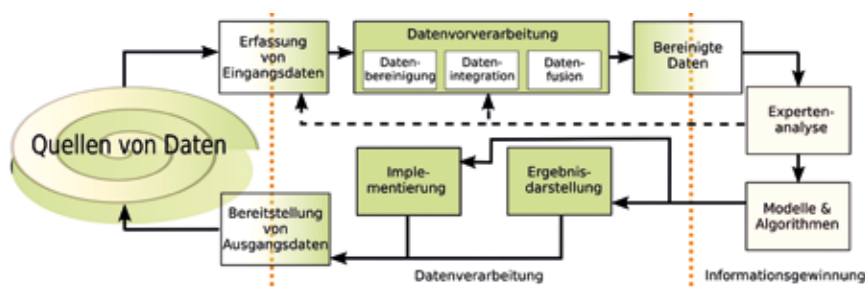

Figure 2: Data management and analysis process



Figure 3: Data format used in SMMEXS

Subproject 2.1: Monitoring of scour and marine growth

In this subproject, the long-term wind and sea measurements on the FINO1 platform are analyzed. In addition to a description of the wind and wave characteristics, the investigations carried out on this database include in particular the correlation of wind and wave directions, which can have a major impact on loads, especially in dynamically reacting OWTs. A sample resulting scatter diagram and correlation is shown in Fig. 5.

An important conclusion of this subproject is the fact that the direction and combination of wind and wave effects with recurrence periods of several decades are location dependent. At the location FINO1, the effective directions of the wind velocity and the significant wave height differ by 45° - 60°. At the location FINO3, 140 km northeast of the FINO1 location, the wind speed and the significant wave height Hs50 have almost the same effective directions.

Subproject 2.2: Identification of condition parameters

This section identifies parameters that describe the condition of a wind turbine. A state refers primarily to the state of damage of the entire wind turbine. Parameters are characteristic quantities of time series, for example, statistical quantities, natural frequencies or residuals. Changes in the condition parameters, however, do not exclusively result from structural damage. They can also result from plant operation, environmental conditions, structural boundary conditions and measurement errors. Accordingly, it is examined which influences are recognizable in the state parameters and whether these influences allow damage detection. In addition, the condition parameters are determined using measured data from the *alpha ventus* wind farm (Fig. 6), thus providing a realistic assessments.

Identification of such parameters is done via Artificial Neural Networks, and show that both the Frequency Domain Decomposition and the Artificial Neural Networks are applicable in real offshore wind turbines and complement each other. The natural

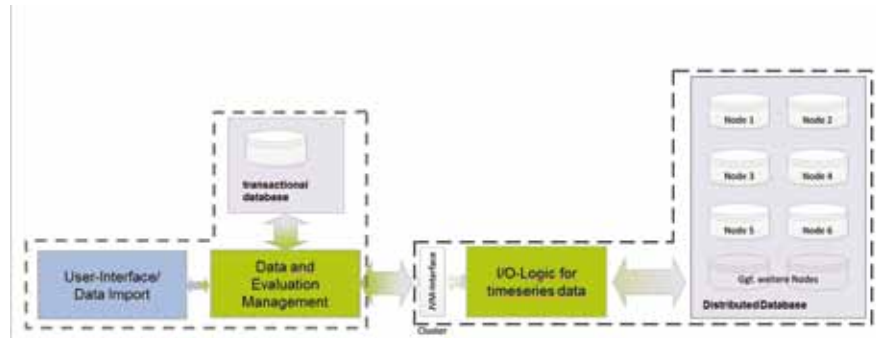

Figure 4: Concept of data management and analysis system

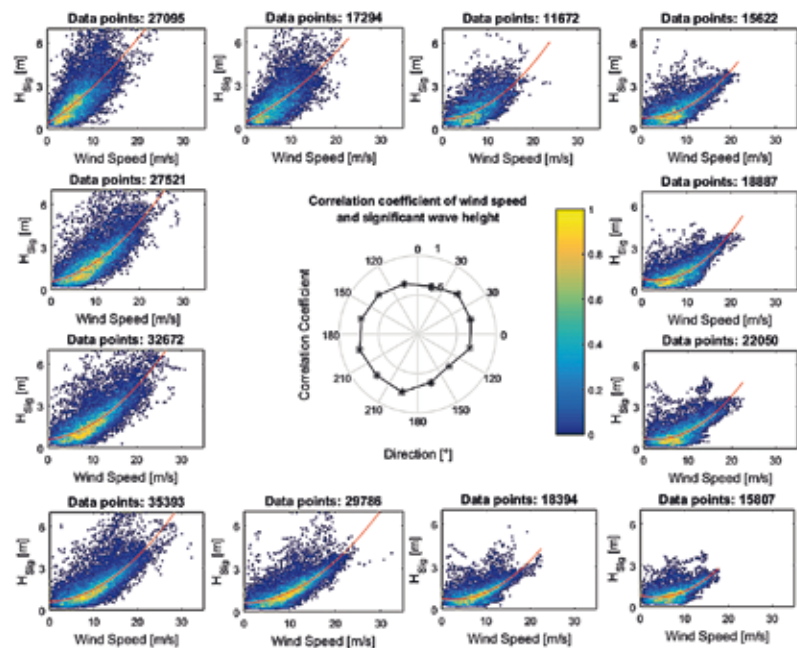

Figure 5: Scatter diagram of wind speeds and significant wave height

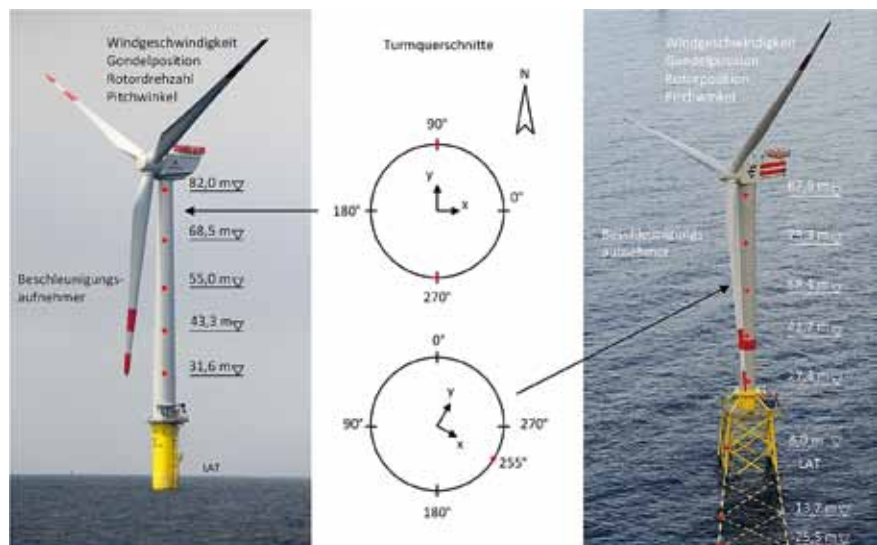

Figure 6: Overview of data points and sensor positions. Left: AV07 Adwen OWT on a tripod. Right: R04 Senvion OWT on a jacket

frequencies and eigenmodes provide a first overview of the overall dynamic behavior of the system and the influences of environmental and operating conditions. The singular value decomposition curves indicates excitation frequencies, noise influences and signal energies.

Subproject 2.3:
Monitoring experiments to estimate hydrodynamic masses

The effect of hydrodynamic masses by marine growth is investigated based on varying modal parameters. To determine these effects, both "Datadriven Stochastic Subspace Identification" (SSI) (see [23], [24]) and the Frequency Domain Decomposition (FDD) are used.

Marine growth was applied via synthetic sheets, shown in Fig. 7, having a scaled surface roughness and density similar to marine growth.

Results obtained from SSI and FDD show that the degree of marine growth has little influence on the first natural frequency, but a



Figure 7: Application of synthetic sheets as marine growth

visible effect on the second and third natural frequencies.

The difference in influence is due to the fact that the marine growth was located where the eigenmodes of higher natural frequencies have larger shifts.

The modal damping increases significantly for all eigenmodes, as more friction is introduced by the marine growth due to its roughness.

Subproject 2.4:
Monitoring experiments with damaged structures

Since both marine growth damage has an influence on the modal parameters of a structure, it is of paramount importance to determine differences between the influence of marine growth and damage. As in subproject 2.3, the "Datadriven Stochastic Subspace Identification" (SSI) (see [23], [24]) and the "Frequency Domain Decomposition" (FDD) are also used to determine these effects.

Various degrees of damage were applied symmetrically at the pile structure, which was scaled in the sub-projects 4.3 and 4.4. Damage was implemented via saw cuts having following depths: 2 mm, 7 mm, 12.5 mm and 25 mm. The sawn pile is shown in Fig. 8. In all tests of the damaged structure a marine growth was applied.



Figure 8: Application of damage to experimental pile

Results obtained from SSI and FDD show that damage has a visible influence on all natural frequencies, with the highest influence on the first natural frequency. Furthermore, damage greater than the wall thickness, leads to the ingress of water into the structure and produces a jump in all natural frequencies.

Subproject 2.7:
Inspection intervals for tower and substructure from degradation

The investigations of grout joints (SP 3.6), welded components (SP 3.7) and screws (SP 3.8) have shown that during the service life of the OWT, no degradation effects are expected on these structural components of the support structure. However, the bedding conditions change due to scouring. Furthermore, marine growth affects the loads on the structure. Both effects lead to a changing structural stiffness of the OWT and also to changed loads.

During the design of OWT, assumptions for such degradation phenomena are made according to the relevant standards. However, ongoing OWT measurement and monitoring can provide detailed information on the current status of degradation, allowing more accurate estimation of OWT exposure and remaining service life.

Marine growth:

Several investigations took place in the area

of *alpha ventus*, focusing on marine growth. The growth fauna on the research platform FINO1 was recorded between 2005 and 2007 in spring, summer and autumn [25]. In the *alpha ventus* offshore wind farm, measurements were taken from 2009 to 2012 on up to four supporting structures (see [26], [27], [28], [29]). The supporting structures investigated here are mainly populated by mussels up to a water depth of 5 m. The results of the investigations listed are shown in Fig. 9 for both the FINO1 research platform and the OWT M7, M12, R1 and R6 offshore wind farm *alpha ventus* for water depths of 1, 5 and 10 meters. The thickness of the marine growth results from the wet mass per area determined in the investigations and a density of 1325 kg / m³. The effect of marine growth on natural frequencies is shown in Fig. 10.

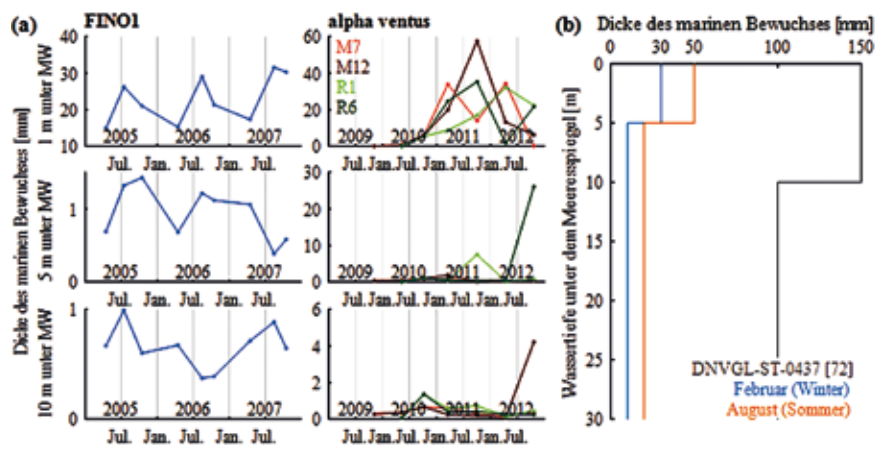

Figure 9: (a) thickness of marine growth at FINO1 and in the offshore wind farm *alpha ventus*; (b) derived models of marine fouling for different months and the approach according to [72].

Scour:

Scouring has a direct impact on the structural response of OWT. Investigations of scour formation in monopile substructures show that the structural dynamic properties of OWT change significantly with increasing scouring depth [30]. Furthermore, it leads to the increase in fatigue loads [31]. The effect of scour in natural frequencies is shown in Fig. 11.

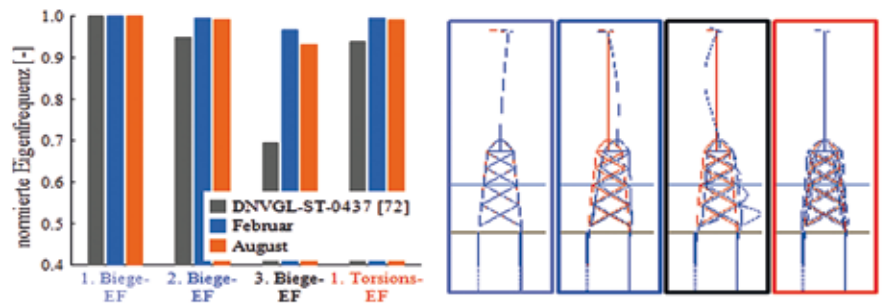

Figure 10: Relation between natural frequencies of an OWT with jacket support structure and different models of the marine (EF).

Fatigue Loads:

With increasing marine growth, both the cross section and the surface change, thus increasing the wave-induced loads on the jacket support structure. When using the Morrison equation (see description in SP 5.3), higher hydrodynamic drag coefficients are used, the values of which are taken from, for example, [32]. Furthermore, the investigations carried out show that the fatigue loads of an OWT with jacket support structure are increased with increasing scour. Therefore, the monitoring of scour development is necessary to be able to estimate the fatigue load during operation.

Subproject 2.8:

Degradation models for steel elements from measurements

In order to validate the developed degradation models with realistic loads, numerical holistic simulations of OWT are carried out

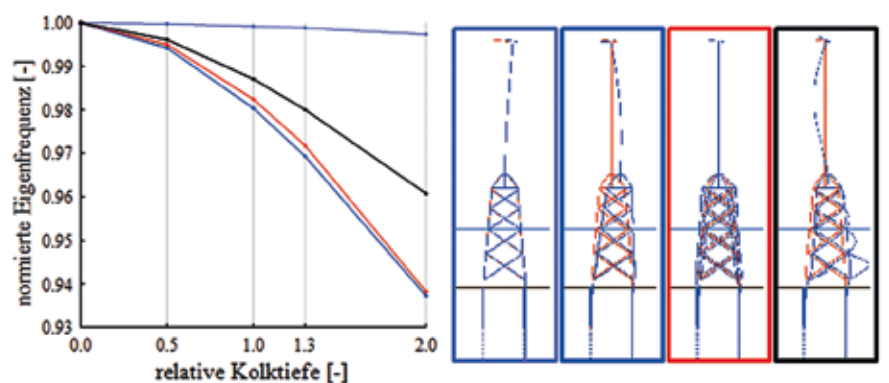

Figure 11: Relation between natural frequencies of an OWT with jacket support structure and different scour depths.

on the basis of measured environmental parameters. The holistic numerical simulations were performed for the normal, undisturbed operation of the OWT according to the design load case DLC 1.2 (DLC, design load case) according to IEC 61400 3 [33]. Both long-term and short-term statistics are considered. The long-term statistics include the distribution and correlation of the measured environmental parameters. The short-term statistics take into account the stochastics of the generated time series. The long-term statistics of environmental parameters are shown in Fig. 12.

To determine the structural stresses according to DLC 1.2 [33], two load time-series with a length of ten minutes are generated for each load combination, as shown in Fig. 12 (right). For this purpose, the finite element software Poseidon was used, which is coupled with the program Flex5 to determine the wind-induced rotor-nacelle loads [34]. The sea states, whose induced loads are applied to the support structure within the Poseidon software, are modeled as a JONSWAP spectrum, as explained in [34] or [35]. The fatigue loads are determined from the time series of the structural stresses generated in the OWT's holistic simulations using the rainflow counting algorithm, as described in [36]. The determined fatigue loads are used for the investigations carried out in subproject 3 on Grout joints (SP 3.6), welded components (SP 3.7) and screws (SP 3.8).

Subproject 2.8:

Developments of the measurement unit
 In GIGAWIND *alpha ventus* project, a mobile measuring unit was developed at the Institute for Building Materials. This was installed and tested under maritime conditions on the support structure of a fully operational offshore wind turbine. After a 22-month measurement on a tripod structure in the North Sea, it was returned (see Fig. 13). The aim of the project is to analyze the salvaged prototype measurement unit, to identify its weak points and to increase their performance and reliability in a further development.

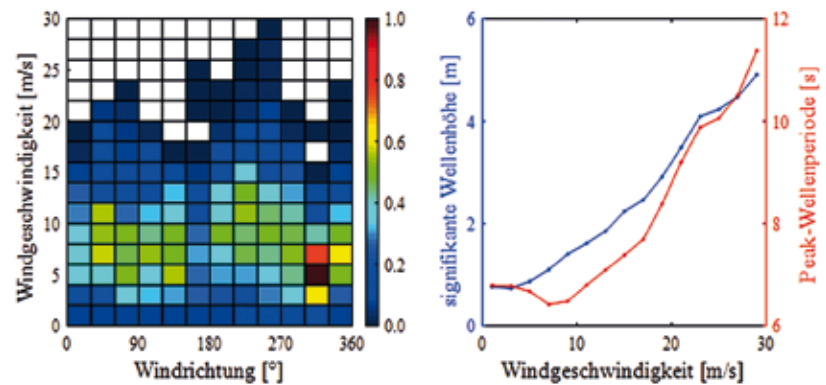

Figure 12: Long-term statistics of the environmental parameters on the research platform FINO1: (left) Frequency distribution of wind direction and wind speed at hub height in 2010, (to the right) to the wind speeds associated averaged sea state parameters

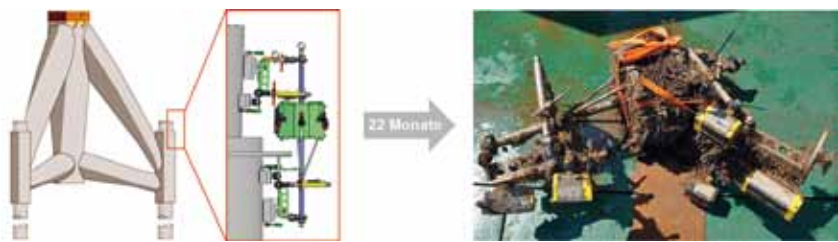

Figure 13: Tripod structure (left), CAD model of the prototype measuring unit made of GIGAWIND *alpha ventus* (center) and salvaged prototype measuring unit after 22 months of use (right)

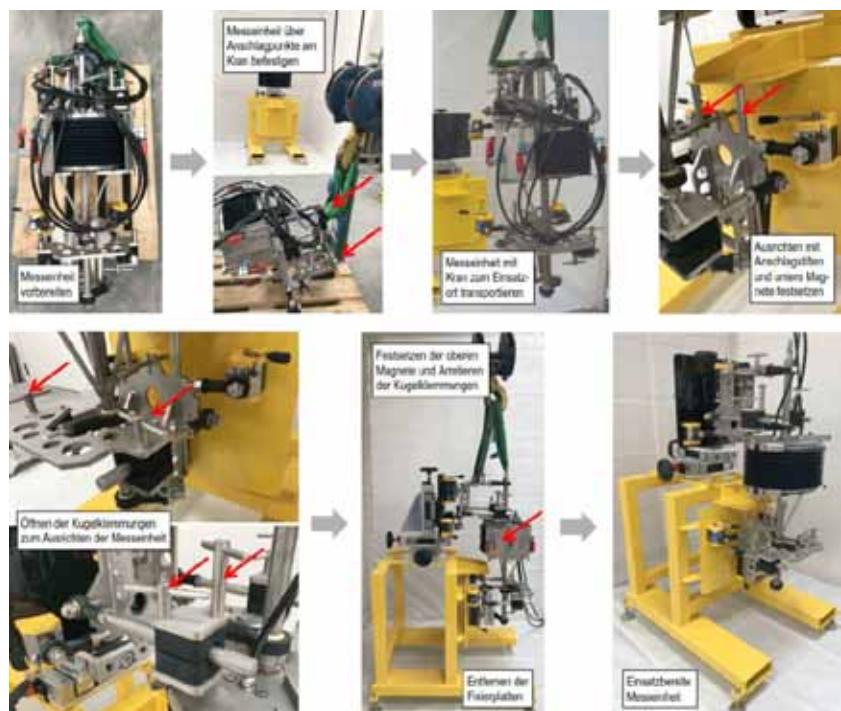

Figure 14: Assembly procedure of measuring unit II.

The resulting new measurement unit avoids all identified weakspots and has a higher performance and reliability. The assembly procedure of the new measuring unit is shown in Fig. 14.

Subproject 2.10:

Mineral corrosion protection: tests and repairs

To estimate the anticorrosive effect of the mineral corrosion protection system under real conditions, retrieval experiments on an offshore wind turbine in the *alpha ventus* test field are carried out. The aim of this investigation is to detect and analyze the corrosion protection effect of the specially developed mineral corrosion protection system. In addition to the analysis of the corrosion-protecting effect of an intact mineral corrosion protection layer, the analysis of a damaged (cracked) protective layer is also the focus of the investigations. For this purpose, special specimens, the so-called test coupons, are designed and manufactured for a period of ~ 1.5 years. The manufacturing process of the test coupon is shown in Fig. 15.

The resulting new measurement unit avoids all identified weakspots and has a higher performance and reliability. The assembly procedure of the new measuring unit is shown in Fig. 14.

Due to the difficult environmental conditions that exist in offshore wind turbines, there are currently almost no repair concepts or principles for these structures. Thus, the corrosion protection for these structures is usually measured and designed for the entire service life, so that a repair of the systems during this time is not required. In the case of damage, however, systems of this type can hardly be repaired using conventional methods. Here, a problem-free application both above and below the waterline is possible.

A comparable repair procedure has already been used on a trial basis on foundation piles of a naval structure [37]. In the process, a space is created between the component surface and a formwork (grid), in which mortar is introduced under pressure

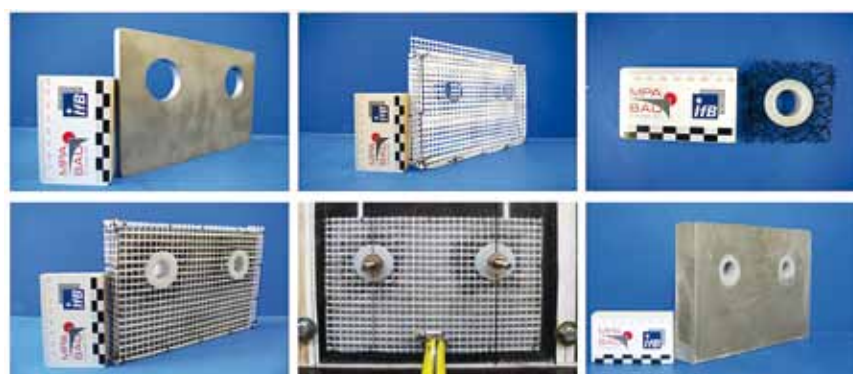

Figure 15: Multi-stage manufacturing process of the plate-shaped test coupons

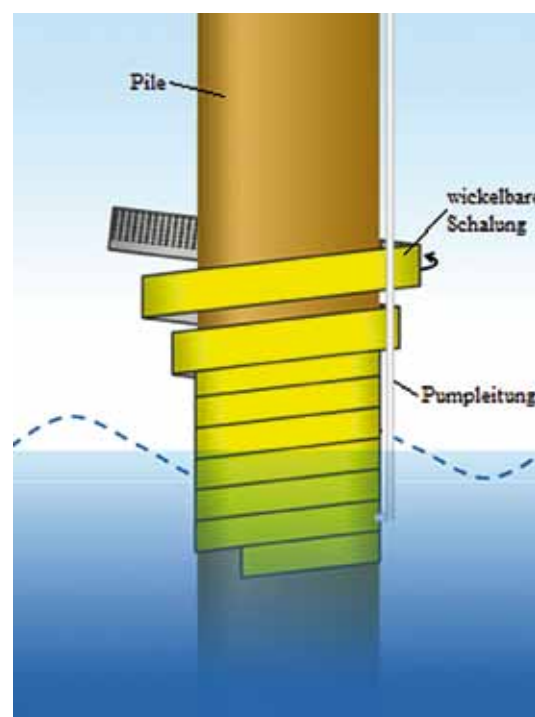

Figure 16: Schematic representation of a possible spiral wound plastic formwork with internal textile reinforcement for application of the mineral corrosion protection system

and the existing water is displaced. The placement of a suitable formwork poses a great challenge in the case of a pile of an offshore wind energy installation due to the geometry. One possible variant could be a water-impermeable plastic formwork with an inner textile reinforcement wound spirally around the pile (see Fig. 16). The textile reinforcement serves to limit the crack width in the mortar layer and as a spacer between the component surface and the plastic surface. The resulting gap can be pumped with mortar from below and the water can be displaced upwards.

Subproject 2.11:

Realistic stresses from *alpha ventus* measurement data

The measurement of stresses on the support structure of offshore wind turbines allows realistic load assumptions for frequently occurring events as well as for rare extreme events. Prerequisite for reliable statements on rare loads are measurement series that span several years. For this purpose, the strains on the anchoring piles of the jacket of the R4 turbine of the offshore wind farm *alpha ventus* are examined. Due to numerous measurement failures, only short meas

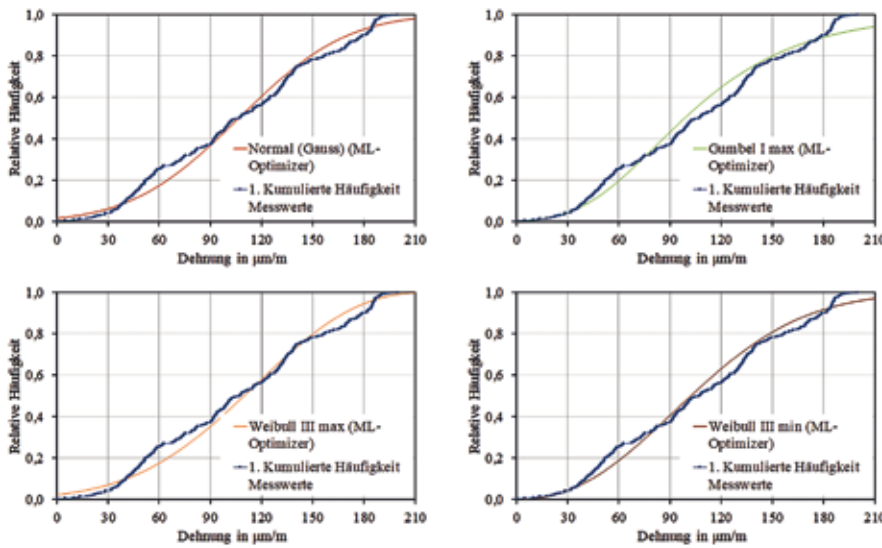

Figure 17: Empirical distribution of the day extremes of strains at the R4_D-E1_1 stake and various distribution functions

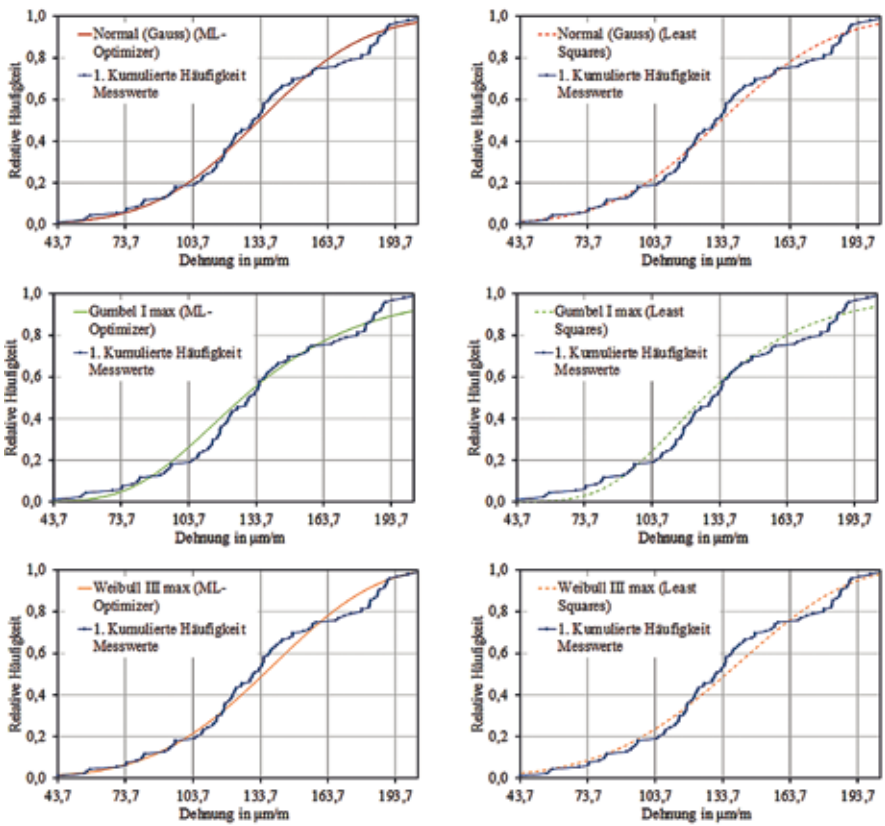

Figure 18: Empirical distribution of the week extreme values of strains at the R4_D-E1_1 stake and various distribution functions

urement time series of individual strain gauges are evaluated and related to the exposure parameters from subproject 2.1.

The distribution of daily extreme values of pile strains are shown in Fig. 17. It is well described by the Weibull III max distribution function. This applies in particular to the upper quantile range.

An example of the empirical distribution of the week extreme values of the strains at the R4_D-E1_1 stake in the observation period 19.10.2010 to 03.05.2013 (see [38]) is shown in Fig. 18.

The Weibull III min distribution is not suitable for describing the empirical distribution of strains in this database. In addition to the maximum likelihood method, the least square method is also used to estimate the distribution parameters. However, the estimation methods used have only a very small influence on the course of the distribution functions. Also, the illustrated empirical distribution of the weekly strain extremes can be well described by the Weibull III max distribution.

With the statistical description of the pile strains, linear and elastic material behavior can be used to infer maximum and minimum strains of longer recurrence periods.

Subproject 3.1: Effect of marine growth on load coefficients

Basics of wave and current loads on monopiles were extensively studied in recent years, especially in wave channels, which generate unidirectional waves. However, loads are caused by wave spectra, which scatter in their direction. Using the directional spectra, natural seaways are modeled much more accurately. Investigations of this kind are carried out in wave pools in which multidirectional sea state can be generated. Extensive tests were carried out on combined wave and current loads for load analysis and scour development, which are described in detail in the subproject 4. In the following, the findings of the experiments are used to show the influences of marine growth and interacting waves and currents.

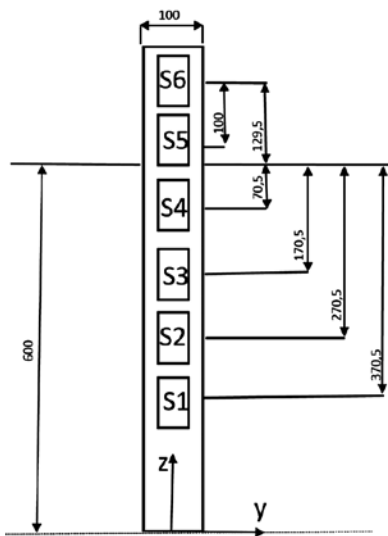

Figure 19: Position of measuring sensors 1-6 with reference to the water level. Position of measuring segments 1-6 with reference to the water level

The installed force sensors on smooth and marine grown cylinders are shown in Fig. 19. The measured forces are compared to those determined by the Morrison equation.

Subproject 3.2:

Time-dependent scour development and seasonal effects

In addition to a reliable estimate of expected maximum scour depths, an accurate prediction of the time-dependent scour development is required, in particular for the determination of suitable times for the installation or maintenance of offshore structures. Based on the adapted model experiments described in subproject 4.4, approaches for the description of the time-dependent scour development as a result of tidal flow and multidirectional seaway load are presented in this subproject. A comparison between the measured and predicted scour development is shown in Fig. 20.

Subproject 3.3:

Durability of mineral corrosion protection Efficient corrosion protection systems are essential for the durability of an offshore wind turbine. In addition to the conventional corrosion protection systems, a mineral corrosion protection system is investigated within the scope of this project. The cor-

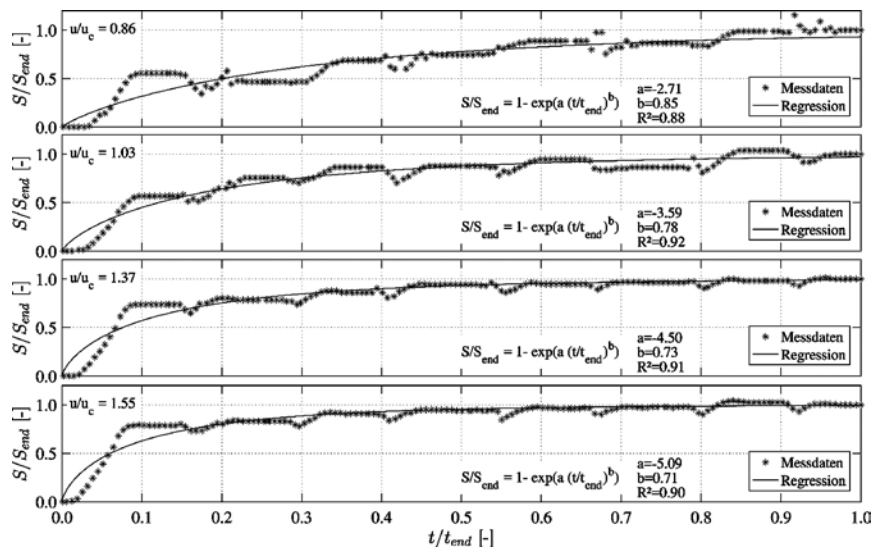

Figure 20: History of maximum scour depths due to tidal flow

rosion protection is intended to protect the steel tower of an offshore wind turbine against corrosion over its service life, especially in the water slushing zone (see Fig. 21).

The protection system is based on the passivating effect of cement-bound building materials, which is well-known from classic reinforced concrete construction.

Subproject 3.6: Grout material degradation under fatigue loads and multi-axial stresses

Offshore wind turbines in the research wind farm *alpha ventus* are installed on the substructures shown in Fig. 22 (left). Six of the twelve installed systems are based on tripods and six on jackets. The anchoring of the foundation structures in the seabed is realized via rammed steel pipes. For the transfer of force between foundation structures and ground pile, a Grout joint is used,

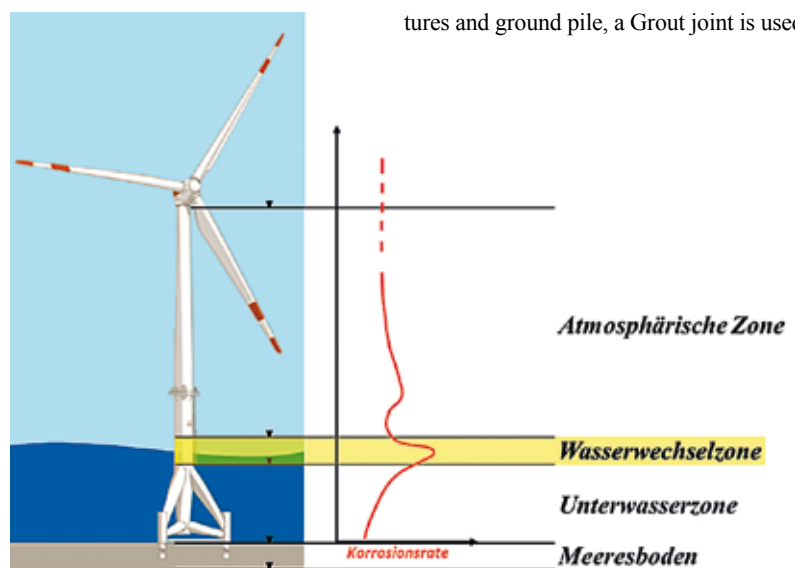

Figure 21: Schematic representation of the corrosion rate of an OWT [112].

as shown schematically in Fig. 22 (center, right). In this connection, a small steel pipe is inserted into a large steel sleeve, and the resulting cavity is filled with a high strength mortar. In order to ensure a force transfer between steel and grout, the surfaces are profiled with build-up welds (shear ribs).

Due to the cyclic stresses of the Grout connection as a result of wind, waves and system operation, fatigue occurs which lead to a degradation of the connection. The objective of subproject 3.6 is to identify these degradation phenomena and to consider them in simulation models. An example of the numerical simulations of the grouted joints is shown in Fig. 23.

Based on the determined realistic loads, numerical simulations were performed to determine the influence of the nonlinear grout material and stress state. The expected degradation of the grout material for the *alpha ventus* jacket was estimated, suggesting a characteristic damage after about 40 years of operation. In order to be able to better track the real degradation state, the application of measurement technology to detect the relative displacement between pile and sleeve is essential.

Subproject 3.8:

Screw preload forces in non-cyclic loading
 To connect the segments of a steel tower for offshore wind turbines, screwed ring flange connections are used (see Fig. 24). These are also increasingly used instead of Grout connections for connecting transition pieces and monopiles. Due to the high dynamic loads and large lever arms HV screw sets with very large diameters M64 or M72 are used. This is also the case in *alpha ventus*. At middle flanges between the tower sections and at the nacelle connection, slightly smaller diameters in the range M36-M48 are usually used. Nevertheless, codes of practice and regulations, which are used for the design of the support structure, are usually validated only for diameters \leq M36. Therefore, the influence of the diameter on the fatigue strength of HV sets in [39] was experimentally investigated.

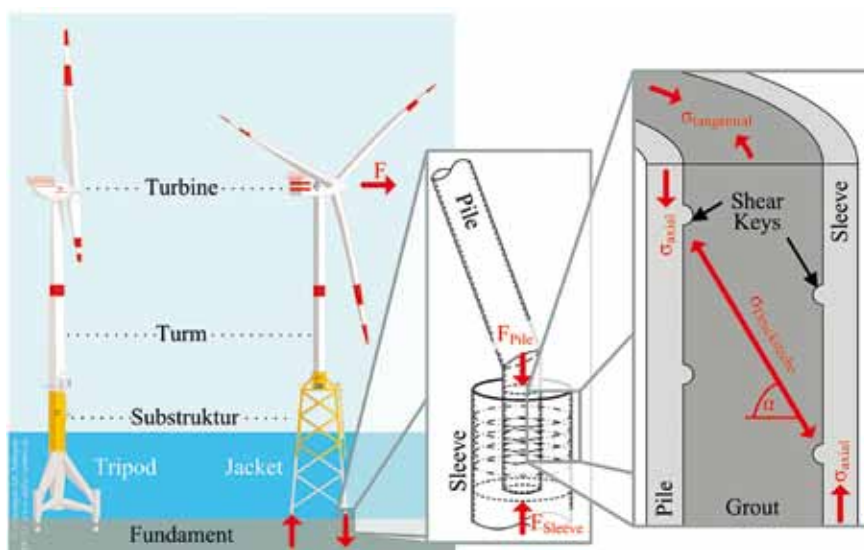

Figure 22: Substructures of the *alpha ventus* wind turbines (left), external view of the Grout connection between foundation structure and ground pile (center) and detailed view of the grout gap with a schematic representation of the structural behavior (right)

Darstellung der normierten minimalen Hauptspannungen im Groutsegment

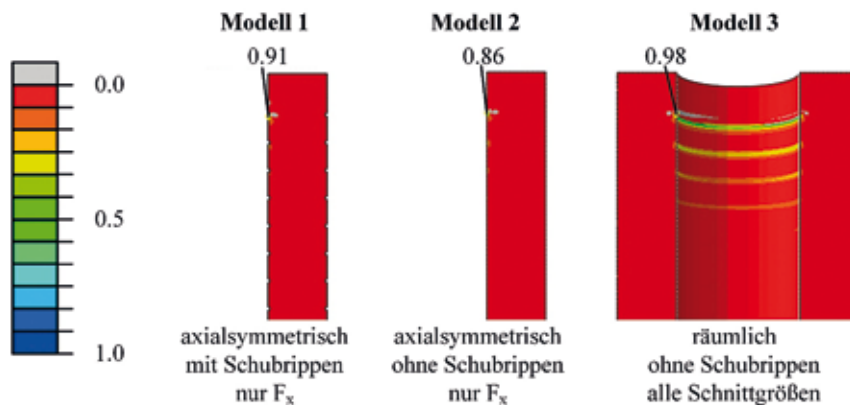

Figure 23: Results of numerical simulations



Figure 24: Positions of ring flange connections in a support structure with jacket supporting structure (left) and HV bolt sets with large diameters (right)

Subproject 3.9:

Method development for the estimation of accumulated pile head deformations

Monopiles are a frequently chosen sub-structure for offshore wind turbines. The diameters of these piles vary between about 5.0m and 8.0m. Under cyclic loads, the piles show permanent displacements and twists. Since offshore wind turbines are sensitive to permanent deformations, especially against misalignments, it is important to be able to determine them as accurately as possible. Some approaches have recently been developed [40], but so far none of these approaches have been established. In the following the so-called Stiffness Degradation Method (SDM) is presented, which was developed and used in extensive parameter studies to determine the pile behavior under cyclic horizontal loads. A selection of these studies and the results obtained from them are the core of this subproject. An example of a finite element model utilized in such methods is shown in Fig. 25.

Subproject 3.10:

Cyclic stiffness of horizontally loaded piles
 For the overall dynamic simulation of offshore wind turbines, foundation stiffness is a key input parameter. It significantly influences the vibration behavior and thus the fatigue loads that occur (see SP 5).

In design practice, lateral foundation stiffnesses are usually applied by the applica-

tion of non-linear modulus methods, so-called p-y methods (see [41], [18]), which describe the soil reaction due to constant loading. In fact, however, the fatigue loads are characterized by the founding reaction due to the continuous unloading and re-loading rather than the reaction to the single constant load.

This subproject is intended to investigate the possibility of applying increased foundation stiffness due to consideration of unloading and reloading stiffness.

Subproject 4.1:

Model experiments on sea spectrums for combined wave and current loads on smooth and rough piles

In this subproject, experiments are conducted to investigate the interaction between waves and current.

In the superposition of waves and currents, the waves deform according to the Doppler effect. If the flow moves in the same direction as the waves, the wavelength is stretched and the wave amplitude becomes smaller. If they run in the opposite direction, the wavelength is shortened and the wave steeper (see [42], [43]). Currents affect waves not only on the surface, but also across the depth to the seabed [44]. The interactions with regard to the formation of swells and structural loads are investigated experimentally.

The experiments were carried out in the wave basin of the Ludwig-Franzius-Institut (Fig. 26). The pool has a size of 24 m * 40 m with a usable length of 30 m and a width of 15 m at a maximum water depth of 1 m. The installed pump capacity of 5 m³/s can generate currents of up to 0.3 m/s at 1 m water depth and correspondingly higher speeds at shallower water depths. Both regular unidirectional and irregular multi-directional waves as well as stationary flow fields can be generated. The flow can be orthogonal as well as oblique to the wave direction. In order to produce the waves with different angles of attack between $\theta = 5^\circ$ and $\theta = 175^\circ$, the plant has a multi-element wave machine with 72 single-wave paddle. Each paddle is 40 cm wide and 1.8 m high and has a maximum stroke of 1.2 m (± 0.6 m) and a maximum speed of 3 m/s.

The direct comparison of the graphs, shown in Fig. 27, shows that the forces in the x-direction for the wave load without flow effect are 10-15% greater than for the forces in the wave direction with combined orthogonal flow influence. Thus, the flow (y-direction) influences the x-components of the wave forces and creates a vector triangle with y-components from the x-forces and thus slightly reduces the original x-force of the wave. In addition, there is a slight (in the graphs difficult to recognize) eccentricity of the forces, which show a shift to the flow-facing side.

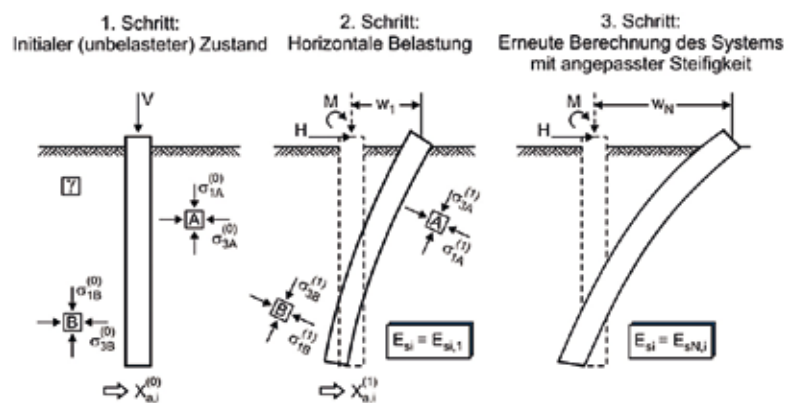
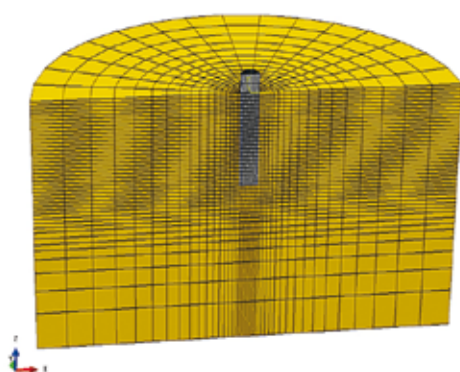

Figure 25: 3D FE model for the num. Simulation and calculation steps of the Stiffness Degradation Method



Figure 26: Wave basin

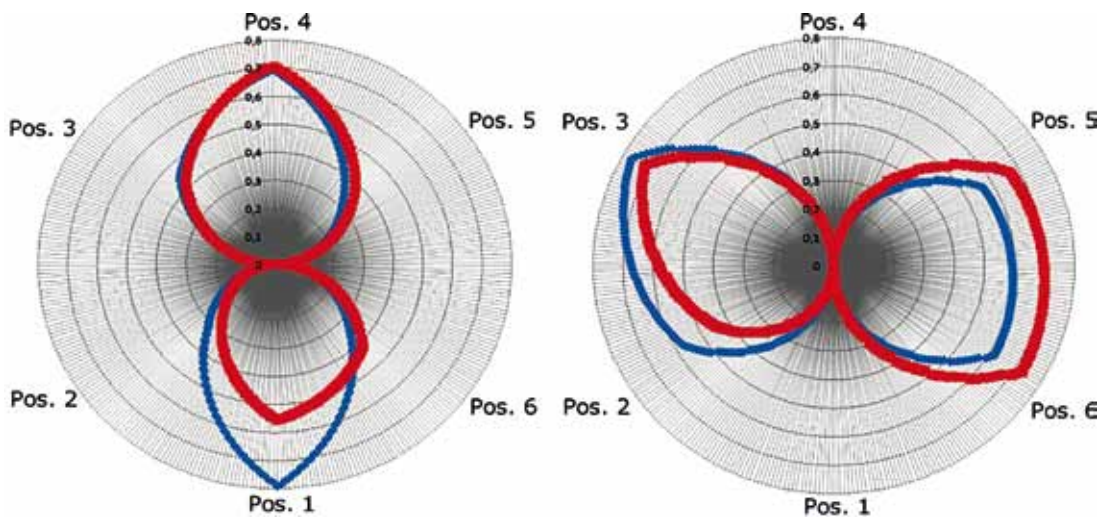

Figure 27: x-forces (left) and y-forces (right) along the circumference of the cylinder with modeled marine growth at the time of the wave crest (blue) and the crest (red) with $H = 6.8\text{ cm}$, $T = 1.2\text{ s}$ and vertical acting Flow at 0.32 m/s

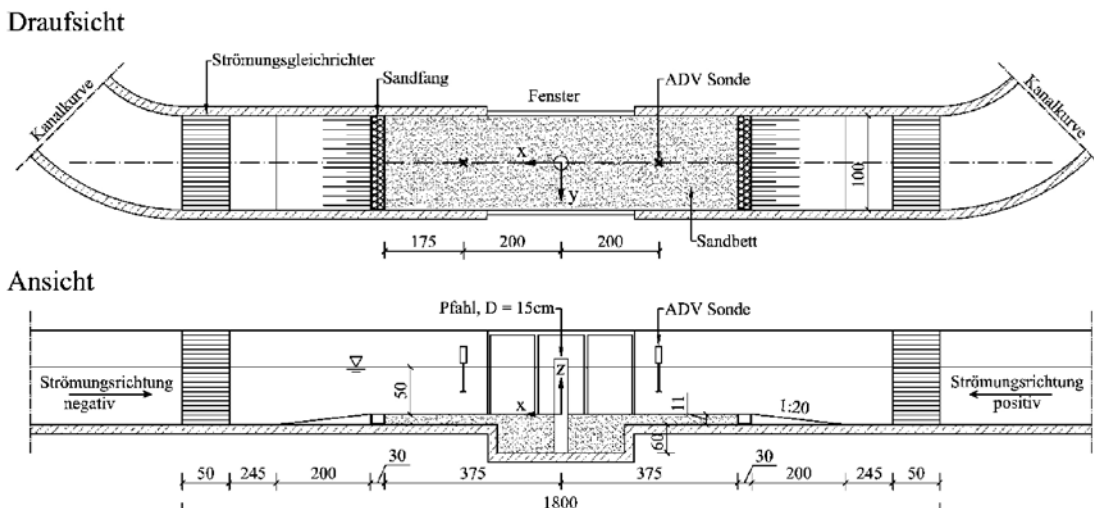

Figure 28: Experimental setup in top and side view [205]. Dimensions in centimeters, not to scale



Figure 29: left: scour development after approx. 8 h with a unidirectional flow load of $u = 0.2 \text{ m/s}$; right: scour development after approx. 8 h as a result of tidal flow with a maximum flow velocity (peak) of $u = 0.25 \text{ m/s}$

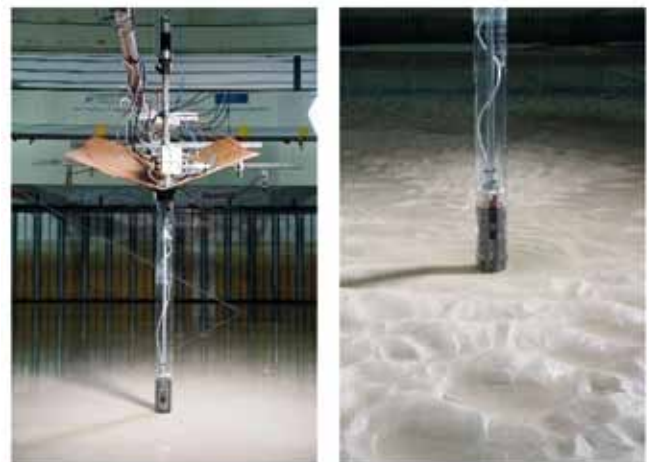

Figure 30: Transparent model pile with installed camera and automated travel system, according to [109]

Subproject 4.2:

Sea spectrum and scouring

In this subproject, experiments are conducted to investigate the generation of scour resulting from sea states similar to the north sea.

The model experiments take place in the circulation channel of the Ludwig-Franzius-Institut. The scale is 1:40. The circulation

channel is driven by a pump system consisting of four individually controllable pipe pumps with a total flow capacity of max. 0.5 m/s. The setup is shown in Fig. 28. Resulting scouring is shown in Fig. 29.

Scouring tests were also performed at the Wave Basin. Resulting scouring is shown in Fig. 30 for multi-directional waves and currents.

Subproject 4.4 and 4.5:

Model tests for hydrodynamic masses and damaged structures

For the experimental investigation of the effects of marine growth and damage on the modal behavior of offshore wind turbines, a scaled model of a supporting structure was used (see Fig. 31) based on the monopile defined in the Offshore Code Comparison Collaboration (OC3) [45]. A variety of sensors were also placed on the structure, which are shown in Fig. 32.

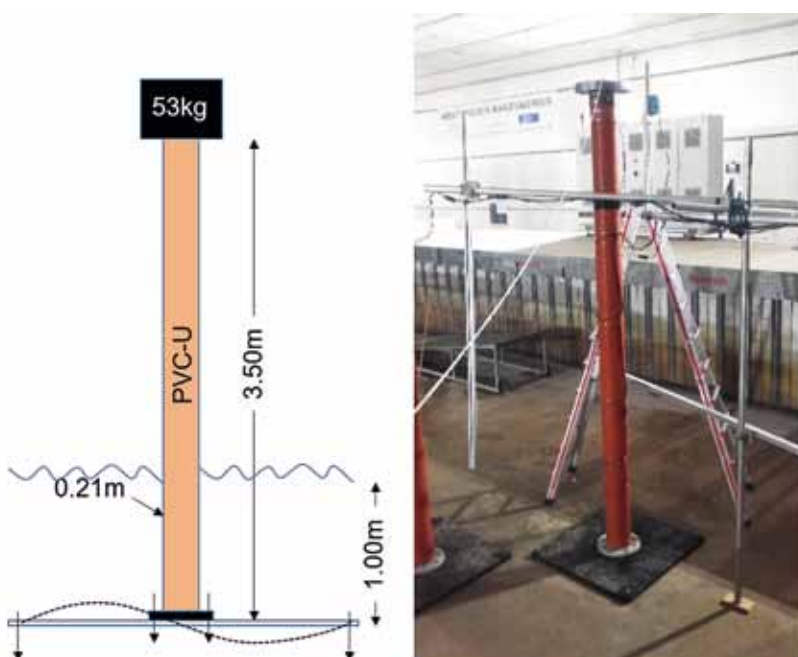

Figure 31: Dimensions of the test structure

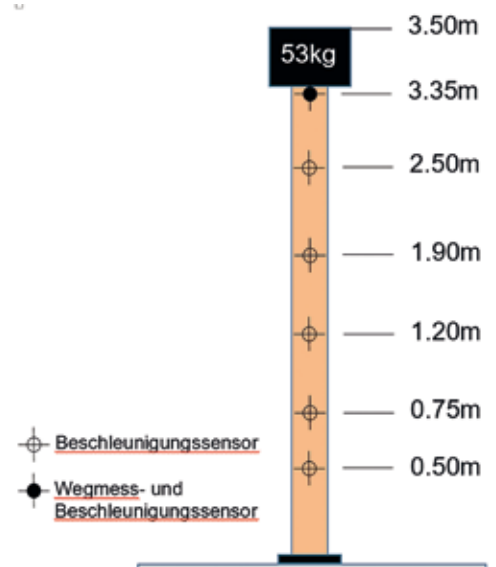

Figure 32: Measurement setup of the test structure

Subproject 4.7:

Model tests for mineral corrosion protection

As described in subproject 3.3, cracks occur within the thin mineral corrosion protection layer as a result of shrinkage or mechanical stress, which favor the chloride entry and increase the risk of corrosion of the steel support structure. The determination of the properties in the non-cracked mortar system is therefore insufficient for an estimate of the effectiveness. With previous test methods, such as the Rapid Chloride Migration Test (RCM) [46], it is only possible to determine the chloride penetration behavior in the non-cracked state. It is therefore also necessary to determine the effects of a self-healing on the chloride penetration behavior.

Cracks are deliberately generated as shown in Fig. 33, which are then installed into migration cells and tested as shown in Fig. 34.



Figure 33: Implementation of cracks in specimens.

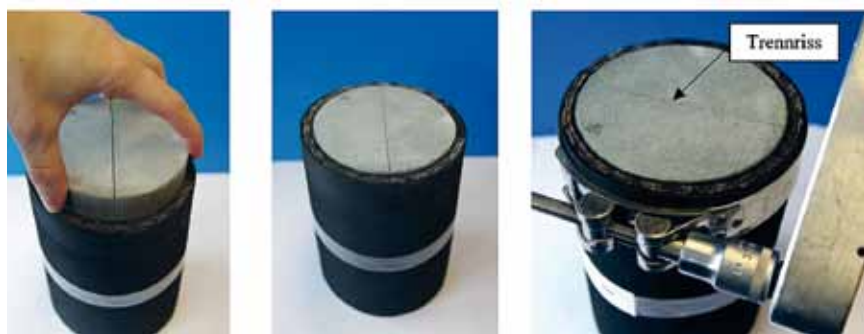

Figure 34: Installation of specimens

Subproject 5.1:

Simulation and design package

In order to standardize all structural models used, the DeSiOLite framework (see Fig. 35) was derived from the previously developed DeSiO framework. It produces input files for predefined structural types for all the simulation tools used in GIGAWIND life. This ensures an improved verification process since all models are consistent.

In order to ensure and improve the networking between the subprojects, interfaces to the monitoring and data management software SMMEXS used in subproject 1 were included. Various import and export filters guarantee the simple migration of simulation data to the central data storage. This facilitates the validation process using measurement data from the offshore test field *alpha ventus*.

Subproject 5.2:

Modular implementation of degradation models

Based on SP 3.6, this subproject describes the implementation of the degradation model of predominantly axially stressed Grout connections in holistic numerical simulations with the help of the software interface POSEIDON-Flex 5. This type of im-

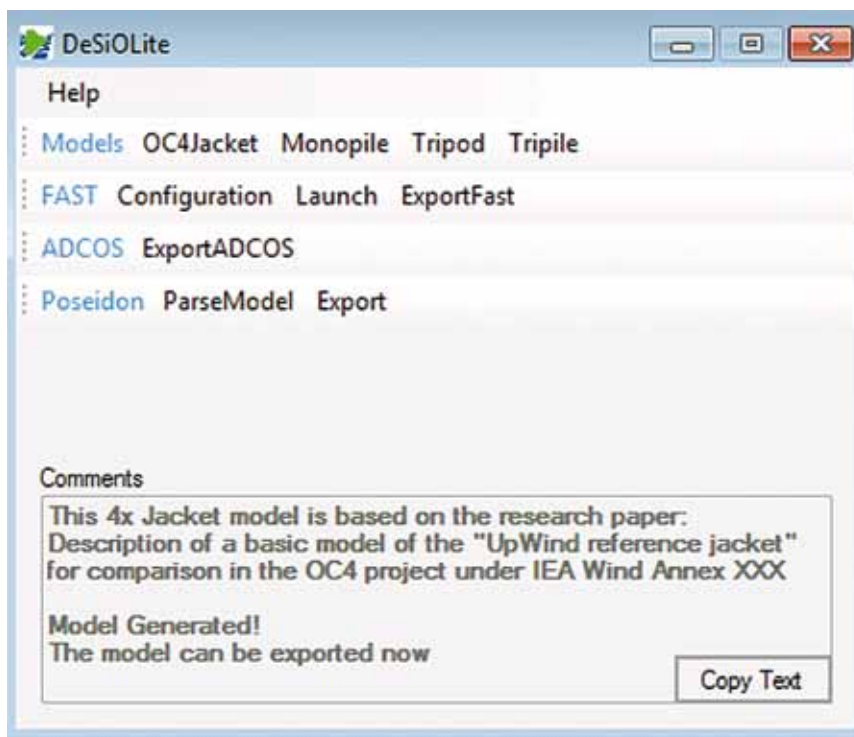

Figure 35: Graphical user interface of DeSiOLite

plementation is comparable to the damage description of welded pipe nodes and differs significantly in the damage hypothesis. The basic flowchart is shown in Fig. 36.

Subproject 5.4:
Dynamic and structural design using a holistic model

When designing OWTs, different types of support structures are considered. The choice of the support structure is often determined by the location-related water depth and the size of the system. Different types of support structures used for OWT in the German North Sea are shown in Fig. 37. Jackets and tripods are well-known as support structure types with pile joints in the offshore wind farm *alpha ventus*. Support structures of floating OWTs, whose use is only an economic option from water depths of 50 m, are not listed here.

The research work performed in this sub-project aims at further developing the parametric monopile support structure in [47] to include other sub structures such as jackets, shown in Fig. 38.

Subproject 5.5:
Validation of simulation tools using measurements from operating wind turbines

In subproject 5.6, new approaches for the modeling of jacket structures were verified. Based on this modeling some selected load cases were examined. Here, the jacket modeled using the classic bar models coupled with a super element approach. To validate the super element approach, the fatigue stresses in the nodal area (a double Y-node on the jacket head and a double K-node) were compared with measurements.

The super element approach provides significantly more realistic results for the maximum node damage, as shown in Fig. 39. The simpler calculations with beam elements are almost always on the safe side in all investigated time. For structural optimization or more realistic calculation of a residual lifetime, the use of the super element approach is recommended.

Subproject 5.6:

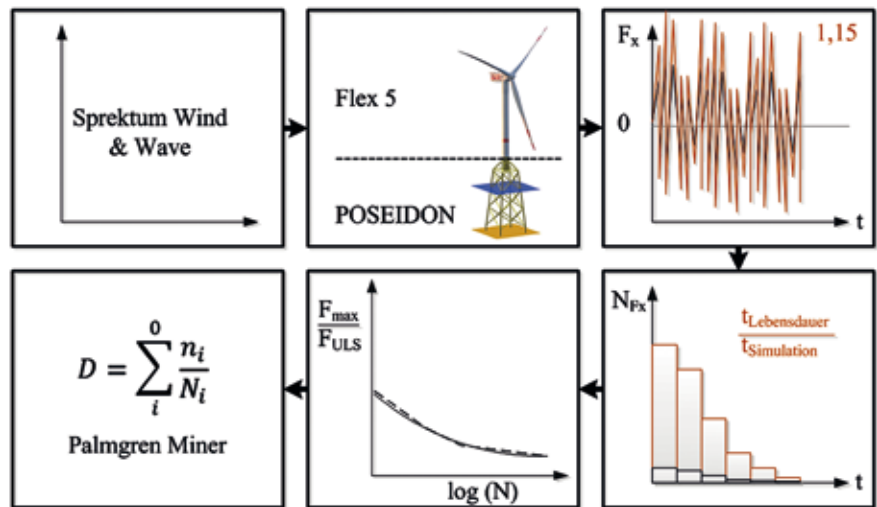

Figure 36: Overview of the implementation of degradation models in the framework

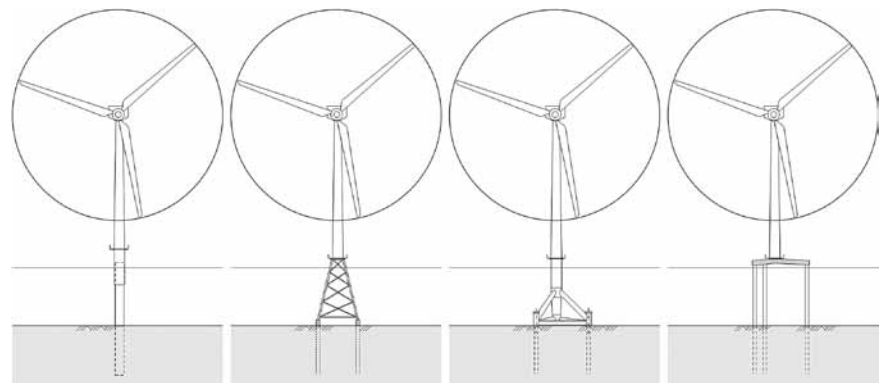

Figure 37: Supporting structures of offshore wind turbines

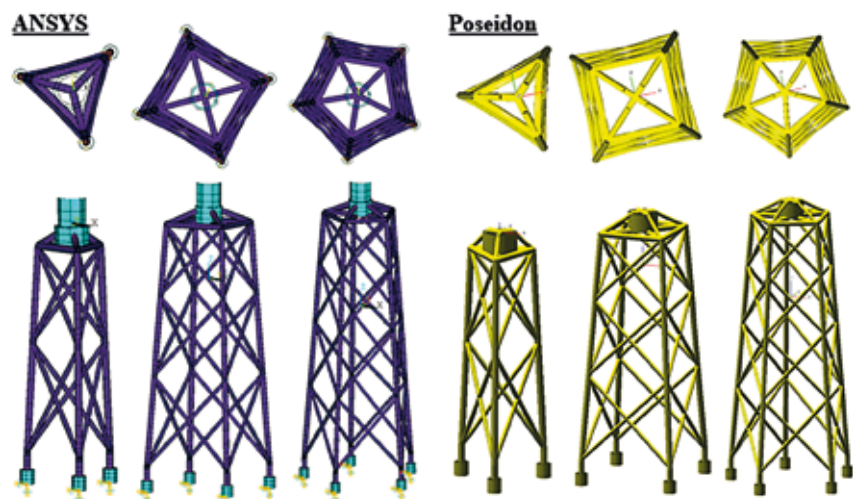

Figure 38: Modeling of jacket substructures. Left: Ansys, Right: Poseidon

Verification of the superelement approach and developed modules: a holistic approach

The developed modules as well as the suggested superelement approach is validated in this subproject. Comparisons with ANSYS, Poseidon and measurement data are performed.

Summary

The project focused on the validation of methods and structural models for an integral and cost-effective design of OWEA support structures. In particular, the following topics were investigated:

In subproject 1, a user database for merging system for laboratory and simulation data was developed.

In subproject 2, monitoring aspects were investigated based on measurement data from *alpha ventus* and laboratory data.

Subproject 3 includes degradation models, developing currently existing methods in *alpha ventus* and introducing new models.

Subproject 4 carried out model experiments to gain insights to phenomena that cannot be derived from *alpha ventus* data.

Subproject 5 represented the merging of the findings from the first four subprojects by using this knowledge in overall simulations to provide forecasts for the overall system behavior.

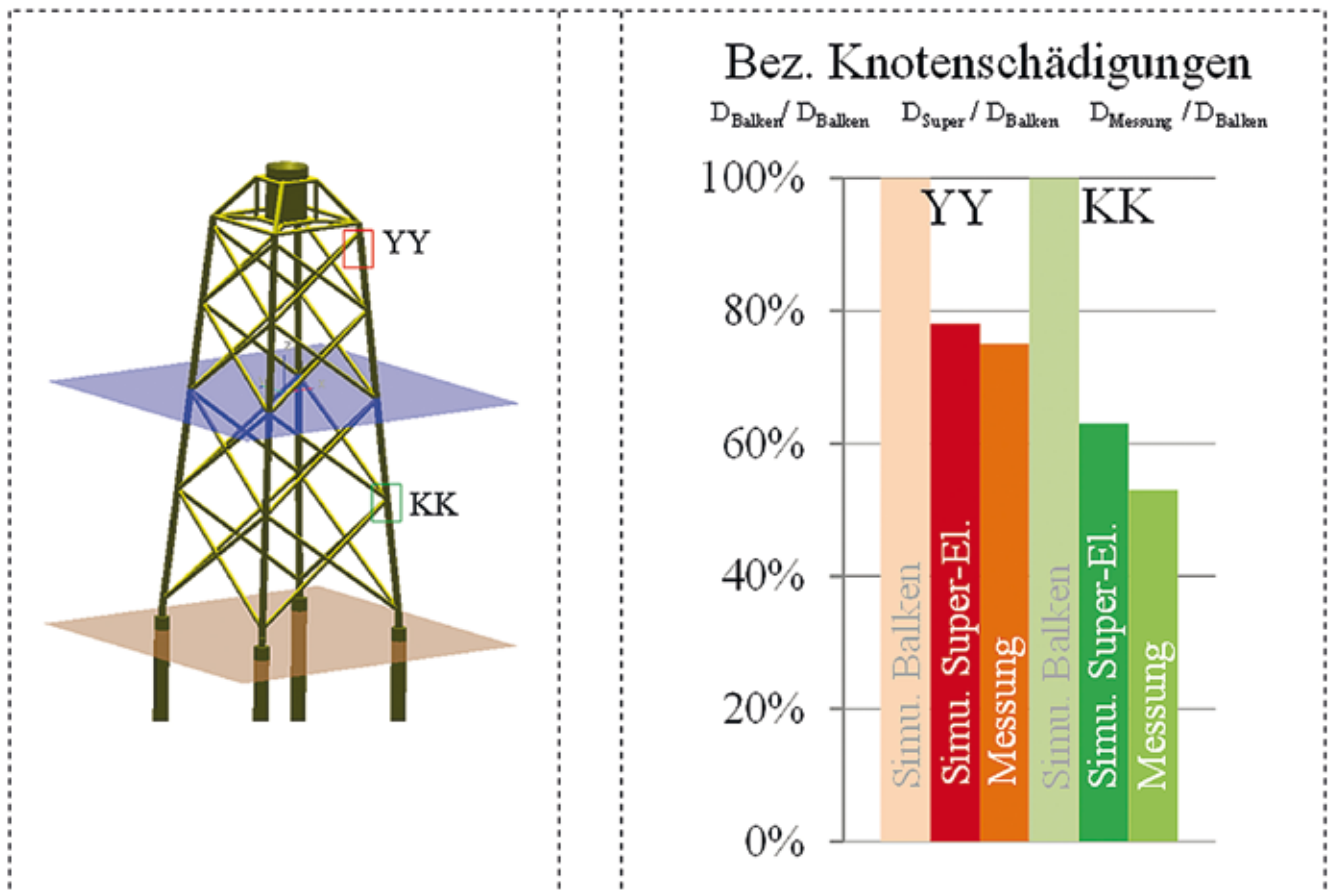

Figure 39: Position and degradation of the considered jacket nodes

References

- [1] Capriolo, E.: Cassandra High Performance Cookbook, Birmingham, Vereinigtes Königreich: Packt Public, 2011.
- [2] White, T.: Hadoop: the definitive guide, Sebastopol, CA, USA: O'Reilly Media Inc., 2012.
- [3] Dong, Y.; Song, R.; Liu, H.: Bridges Structural Health Monitoring and Detection – Synthesis of Knowledge and Technology, Fairbanks, AL, USA, 2010.
- [4] Link, M.; Petryna, Y.; Künzel, A.: Modellbildung und Parameteridentifikation für Grouted Joints an Offshore-Windenergieanlagen, in 4. VDI-Tagung Baudynamik, Kassel, 2012, pp. 259-269
- [5] Germanischer Lloyd: Guideline for the certification of wind turbines, 2010.
- [6] Anders, S.: Betontechnologische Einflüsse auf das Tragverhalten von Grouted Joints, Institut für Baustoffe, Leibniz Universität Hannover, 2008.
- [7] Keindorf, C.: Tragverhalten und Ermüdungsfestigkeit von Sandwichtürmen für Windenergieanlagen, Leibniz Universität Hannover, Dissertation, 2010.
- [8] Lohaus, L.; Weicken, H.: Polymer-modified mortars for corrosion protection at offshore wind energy converters, in 13th International Congress on Polymers and Concrete – ICPC 2010, Funchal, Portugal, 2010, pp. 151-157.
- [9] International Organization for Standardization, Performance requirements for protective paint system for offshore and related structures, ISO 20340, 2009.
- [10] Farrar, C.; Worden, K.: An introduction to structural health monitoring, Philosophical Transactions of the Royal Society A: Mathematical, Physical and Engineering Sciences (365)1851, pp. 303-315, 2007.
- [11] Farrar, C.; Jauregui, D.: Comparative study of damage identification algorithms applied to a bridge: I. Experiment, Smart Materials and Structures 7, pp. 704-719, 1998.
- [12] Chang, P.; Flatau, A.; Lui, S.: Review Paper: Health Monitoring of Civil Infrastructure, Structural Health Monitoring 2, pp. 341-358, 2003.
- [13] Farrar, C.; Lieven, N.: Damage prognosis: the future of structural health monitoring, Philosophical Transactions of the Royal Society A: Mathematical, Physical and Engineering Sciences 365(1851), pp. 623-632, 2007.
- [14] Kraemer, P.: Schadensdiagnoseverfahren für die Zustandsüberwachung von Offshore-Windenergieanlagen, Dissertation, Universität Siegen, 2011.
- [15] Kraemer, P.; Fritzen, C.-P.: Aspects of Operational Modal Analysis for Structures of Offshore Wind Energy Plants, Structural Dynamics and Renewable Energy 1, pp. 145-152, 2011.
- [16] Häckell, M.; Rolfes, R.: Monitoring a 5MW Offshore Wind Energy Converter – Condition Parameters and Triangulation Based Extraction of Modal Properties, Mechanical Systems and Signal Processing 40(1), pp. 322-343, 2013.
- [17] Bundesamt für Seeschifffahrt und Hydrographie: Mindestanforderungen an die konstruktive Ausführung von Offshore-Bauwerken in der abschließlichen Wirtschaftszone (AWZ), BSH Standard Konstruktion, 2015.
- [18] DNV GL: Support Structures for Wind Turbines, Offshore Standard DNV-ST-0126, 2016.
- [19] Jian, Y.; Zahn, J.; Zhu, Q.: Short rested wave-current forces around a large vertical circular cylinder, European Journal of Mechanics B/Fluids 27, pp. 346-360, 2008.
- [20] Forteath, G.; Picken, G.; Ralph, R.; Williams, J.: Marine Growth Studies on the North Sea Oil Platform Monroe Alpha, Marine Ecology 8, pp. 61-68, 1982.
- [21] Dong, W.; Moan, T.; Goa, Z.: Fatigue reliability analysis of the jacket support structure for offshore wind turbine considering the effect of corrosion and inspection, Reliability Engineering and System Safety 106, pp. 11-27, 2012.
- [22] Herrmann, R.; Rabe, J.; Bolle, G.; Marx, S.: Konzepte für Datenqualität und Datenablage bei Entwurf und Umsetzung von Monitoringsystemen, Bauingenieur 92, pp. 537-545, 2017.
- [23] Brincker, R.; Andersen, P.: Understanding stochastic subspace identification, in Proceedings of the 24th International Modal Analysis Conference, St. Louis, USA, 2006.
- [24] van Overschee, P.; De Moor, B.: Continuous-time frequency domain subspace system identification, Signal Processing, 52(2), pp. 179-194, 1996.
- [25] Krone, R.; Gutow, L.; Joschko T. J.; Schröder, A.: Epifauna dynamics at an offshore foundation – Implications of future wind power farming in the North Sea, Marine Environmental Research 85, pp. 1-12, 2013.
- [26] Kazmierczak, F.; Laudien, J.; Fürst, R.; Bönsch, R.: Benthosbiologische Erhebungen während der Bauphase des Offshore-Windparks alpha ventus, Institut für Angewandte Ökosystemforschung GmbH, Neu Broderstorf, 2010.
- [27] Kazmierczak, F.; Preuß, S.; Breyer, S.; Kern, K.; Fürst, R.; Bönsch, R.: Fachgutachten "Benthos" zum Offshore-Windpark alpha ventus – 1. Betriebsjahr, Institut für Angewandte Ökosystemforschung GmbH, Neu Broderstorf, 2011.
- [28] Preuß, S.; Breyer, S.; Fürst, R.; Bönsch, R.: Fachgutachten "Benthos" zum Offshore-Windpark alpha ventus – 2. Betriebsjahr, Institut für Angewandte Ökosystemforschung GmbH, Neu Broderstorf, 2012.
- [29] Preuß, S.; von Allwörden, S.; Nestler, S.; Kazmierczak, F.; Fuchs, A.; Gloede, F.; Breyer, S.; Fürst, R.; Bönsch, R.: Fachgutachten "Benthos" zum Offshore-Windpark alpha ventus – Bericht über das 3. Betriebsjahr, Institut für Angewandte Ökosystemforschung GmbH, Neu Broderstorf, 2013.
- [30] Prendergast, L. J.; Gavin, K.; Doherty, P.: An investigation into the effect of scour on the natural frequency of an offshore wind turbine, Ocean Engineering 101, pp. 1-11, 2015.
- [31] van der Tempel, J.; Zaaijer, M. B.; Subroto, H.: The effects of Scour on the design of Offshore Wind Turbines, in 3rd International Conference on Marine Renewable Energy, Blyth, Großbritannien, 2004.
- [32] DNV GL, Loads and site conditions for wind turbine, Standard ST-0437, 2016.

- [33] International Electrotechnical Commission, Wind turbines part 3: Design requirements for offshore wind turbines, IEC 61400-3, 2009.
- [34] Böker, C.: Load simulation and local dynamics of support structures for offshore wind turbines, Shaker-Verlag, Aachen, 2010.
- [35] Mittendorf, K.; Nguyen, B.; Zielke, W.: Seegang und Seegangsbelastung, in 2. GIGAWIND Symposium, Hannover, 2002.
- [36] Radaj, D.; Sonsino, C.: Ermüdungsfestigkeit von Schweißverbindungen nach lokalen Konzepten, Düsseldorf: Verlag für Schweißen und verwandte Verfahren DVS Verlag GmbH, 2000.
- [37] Westendarp, A.: Instandsetzung von Wasserbauwerken heute und morgen, in: Bundesanstalt für Wasserbau (BAW) (Hrsg.): Erhaltung von Wasserbauwerken und Brücken, Karlsruhe, 2010.
- [38] Germanischer Lloyd, RAVE - Sensor Description AV 04, 2011.
- [39] Schaumann, P.; Eichstädt, R.: Ermüdung sehr großer HV-Schraubengarnituren, in Stahlbau 85(9), Ernst & Sohn, 2016, pp. 604-611.
- [40] Achmus, M.; tom Würden, F.: Geotechnische Aspekte der Bemessung der Gründungskonstruktionen von Offshore-Windenergieanlagen, Bauingenieur 8, pp. 331-341, 2012.
- [41] American Petroleum Institute, Recommended Practice for Planning, Designing and Constructing Fixed Offshore Platforms – Working Stress Design, Recommended Practice API RP 2A-WSD, 21. Auflage, 2000.
- [42] Chakrabarti, S.: Handbook of offshore engineering (Volume 1), Elsevier, 2005.
- [43] Sarpkaya, T.; Isaacson, M.: Mechanics of wave forces on offshore structures, Van Nostrand Reinhold, New York, 1981.
- [44] Schneider, R.: Örtliche Bewertung der Schwingfestigkeit von Gewindeverbindungen, Dissertation, Technische Institut für Darmstadt, 2011.
- [45] Jonkman, J.; Musial, W.: Offshore code comparison collaboration (OC3) for IEA task 23 offshore wind technology and deployment, 2010.
- [46] Bundesanstalt für Wasserbau, Chlorideindringwiderstand von Beton (MCL), Karlsruhe: BAW-Merkblatt, 2012.
- [47] Dubois, J.; Thieken, K.; Schaumann, P.; Achmus, M.: Influence of soil resistance approach on overall structural loading of large diameter monopiles for offshore wind turbines, in Proceedings of the 1st International Wind Energy Conference, Hannover, 2014.

Innovative Wind Conversion Systems (10-20 MW) for Offshore Applications (INNWIND.EU)

Carl von Ossietzky Universität Oldenburg
Institute of Physics,
Research Group: Energy Meteorology,
Research Group: Wind Energy Systems,
Research Group: Turbulence, Wind Energy
and Stochastics

Martin Kühn, Bernd Kuhnle,
Rasoul Shirzadeh, Martin Kraft,
Frederik Berger, Detlev Heinemann,
Joachim Peinke

Funding: European Union's Seventh
Programme for research,
Technological development and
demonstration, Community's Seventh
Framework Programme
FP7-ENERGY-2012-1-2STAGE

Ref.Nr. 308974

Duration: 11/2013 – 10/2017

Introduction

INNWIND.EU is the follow-up of the finished project "UpWind" addressing the vision of a 10-20MW wind turbine. This project identifies further development and innovation needs on system, subsystem, and component level to achieve the objective of a high-performance wind turbine beyond the state-of-the-art. It facilitates the realization of 10-20MW wind turbines by innovations on component level and decreases their time to market for under the premise of cost effectiveness by necessary cost reductions of around 20% for the overall system. The project had a 5 years duration and 27 European partners are involved. The work packages can be divided in integrating, embedding and innovative subcomponent-based packages. The three subsystem work packages focused on the light weight rotor (WP2), innovative, low-weight, direct drive generator (WP3), and standard mass-

produced integrated tower and substructure (WP4). WP1 integrated the innovations in conceptual designs and focused as well on external conditions, wind turbine control and economical assessment. WP5 and 6 embedded the project by being responsible for the management and the dissemination and exploitation.

ForWind – University of Oldenburg participated in the Work Packages 1, 2, 4, lead Task 1.1. "External conditions", Task 4.1. "Innovations on component level for bottom-fixed support structures" and co-ordinated WP4.

Project Description

In WP1, ForWind – University of Oldenburg, namely the Energy Meteorology group, lead the Innwind Task 1.1. on modelling the wind conditions up to 300 m height. These wind conditions are crucially important for the design of the foreseen 10-20 MW offshore turbines with rotor diameters of up to 250 m and maximum tip heights of up to 300 m. Over such a height range, massive changes in wind speed, wind direction and turbulence can occur, which induce high loads in the blades and the whole turbine. To model these conditions correctly, it is of utmost importance to simulate the thermal stratification of the marine boundary layer in detail and then to compute the respective heat and momentum fluxes. In WP2, ForWind – University of Oldenburg, namely the Turbulence, Wind Energy and Stochastics group, is involved in the demonstration and validation of new control concepts by experiments at a medium scale turbine reproducing atmospheric turbulence in a wind tunnel. The task here is to design and built an active grid for the open jet facility of the Delft University of Technology. This wind tunnel has a cross section of 3 times 3 m² and will be used for some of the experiments in the work package.

WP4 addressed the challenges for the support structure in the 10-20MW wind turbine class. ForWind – University of Oldenburg, namely the Wind Energy Systems group, co-lead the Work Package and coordinated Task 4.1. The combination of large water depth and tall hub height due to the large rotor, as well as large thrust forces and dynamic loading results in strongly increased demands for the support structure. Furthermore, the increased rotor diameter yields in low rotational speeds and therefore possible excitations of the natural frequency of the relatively stiff support structure by the rotor or blade passing frequency. ForWind – University of Oldenburg was engaged in load mitigation concepts both by sophisticated control of the rotor-nacelle-assembly with respect to the support structure as well as structural control concepts such as active, semi-active and passive damper devices. ForWind – University of Hanover analysed the feasibility of hybrid jackets comprising classical steel tubes as well as sandwich elements to improve the ultimate limit state strength of bottom-fixed multi member support structures. For this purpose an investigation of sandwich elements on component level was performed in Task 4.1. The conceptual design of a hybrid jacket is made in Task 4.3.

Summary

The first step in WP1 and especially Task 1.1. was to compile and analyze existing measurements of the offshore wind resources at higher atmospheres. Now the Energy Meteorology group has set up various numerical modeling schemes for the analysis of different weather situations, including extreme events. Especially, the results with the meso-scale model WRF using the MYJ-scheme for the Planetary Boundary Layer (PBL) proved to be the best technique, compared to other models and PBL-schemes. The next step will be the implementation of

these results in simpler 2-dimensional and engineering models. In WP2, an active grid is used to generate customized turbulence for wind tunnel experiments. The used active grid divides the cross section by 80 horizontal and vertical elements, resulting in a mesh width of about 0,14 m. Each of its axes is connected to a servomotor in such a manner that each can be controlled individually by a real time system. Mounted on the rods are square flaps which are, depending on the orientation with respect to the inflow, blocking and deflecting the wind. Dynamic changes of the angle of attack of the flaps to the flow are in the following described as an excitation protocol. The excitation protocol defines the dynamics of the generated turbulence. As part of the project different excitation protocols were developed and the used active grid were built to test the concept of Subspace Predictive Repetitive Con-

trol (SPRC), a data-driven control technique developed by the Technical University of Delft. In Fig. 1 the setup in the wind tunnel is shown.

In WP4, load mitigation strategies have been analysed with respect to fatigue loads on the support structure. These have been separated in control concepts and damping devices. Firstly, control related load reduction technologies like speed exclusion zone and peak shaver have been included to reduce oscillations in the low wind operational mode as well as thrust reduction near rated wind speed. Secondly, concepts for tower dampers have been analysed. Passive Tuned Vibration Absorbers (TVA), Tuned Mass Dampers (TMD) and Viscous Fluid Dampers (VFD) have been implemented in the aeroelastic models of the 10 MW reference turbine design. Tuned mass

dampers showed a high potential in lowering the fatigues loads in sideways direction. Only small advantages in the fore-aft direction could be seen by implementing these technologies. The stochastic wind input is here the governing factor. Due to higher masses for the 20MW turbine design passive damper technologies showed less performance due to space and mass restrictions for such extra equipment. Active damper technologies, like the magnetorheological (MR) damper showed a higher potential for fatigue load reduction. Further investigations are needed to improve the results and to show the applicability on real structures.



Figure 1: Model wind turbine of the Delft University of Technology in front of 3 m x 3 m active grid in the WindLab wind tunnel

References

- [1] Kuhnle, B.; Kühn, M.: Unfavourable trends of rotor speed and systems dynamics for very large offshore wind turbines - Analysis of the 10MW INNWIND.EU reference turbine, " in EWEA Offshore, Copenhagen, 2015.
- [2] Shirzadeh, R.; Kühn, M.: Application of two passive strategies on the load mitigation of large offshore wind turbines, *Journal of Physics: Conference Series*, vol. 749, no. 1, p. 012011, 2016.
- [3] Shirzadeh, R.: Support structure load mitigation of a large offshore wind turbine using a semi-active magnetorheological damper, in EERA DeepWind, Trondheim, Norway, p. 15 (2017)
- [4] Jensen, P. H. et al.: LCOE reduction for the next generation offshore wind turbines - Outcomes from the INN-WIND.EU project, October 2017

Integrated Research Programme on Wind Energy (IRPWIND)

Leibniz Universität Hannover (LUH)
Institute of Structural Analysis,
Institute of Geotechnical Engineering,
Institute of Steel Construction,
Institute for Risk and Reliability,
Institute of Electric Power Systems

Clemens Hübler, Tim Berthold, Tanja
Grießmann, Andreas Ehrmann, Kirill A.
Schmoor, Karsten Schröder, Matthias
Bode

Funding: European Union's Seventh
Programme for research, technological
development and demonstration

Ref.Nr. Grant agreement no 609795

Duration: 03/2014 – 02/2018

Introduction

IRPWIND is a large EU project in the wind energy sector with 24 international partners. Its aim is to foster better integration of European wind energy research activities with the objective of accelerating the transition towards a low-carbon economy and of maintaining and increasing European competitiveness. In this context, IRPWIND includes several non-research aspects (work packages WP 1-5) that are intended to improve the European collaboration. An example is the mobility call for experienced researchers (WP 5) to transfer knowledge. In research, IRPWIND focusses on three main aspects. The first one is the optimization of wind farms through the validation of integrated design models (WP 6). The second one is the reduction of the uncertainty in order to increase efficiency and reliability of future wind turbines (WP 7). The last one is the transformation of the energy supply system (WP 8). LUH is involved in all three research aspects.

Project Description

IRPWIND with more than ten WP and about 50 tasks covers a broad range of topics in the wind energy sector. That is why only some WP in which LUH was involved can be presented here.

WP 7.2 is intended to improve and validate the structural reliability of offshore wind turbine support structures. One task in this WP is the conduction of large-scale geotechnical tests with model structures. This means that pile foundations were tested in the large geotechnical test pit (10 m depth, 14 m large and 9 m wide) in the new Test Center for Support Structures in Hannover (see Fig. 1).

The large-scale tests are intended to determine soil-structure interaction effects in order to support probabilistic calculations of the reliability of offshore wind turbine support structures. The calculations itself were performed in WP 7.4 of the IRPWIND project. Six piles (lengths of 5-7m and diameters of around 0.3m) were tested statically and dynamically to determine, inter alia,

the static maximum tension bearing capacity. Some results of these tests are shown in Fig. 2.

In WP 7.4, the results of these tests were analyzed. First, existing theoretical methods for the determination of the maximum tension bearing capacity of statically, axially loaded piles (jacket piles) were validated or rather their model error was determined using the data of the pile load tests. Second, the data of the dynamic tests was used to validate existing approaches for the lateral soil stiffness (p-y curves), if these methods are applied in a dynamic context. For the first aspect, one exemplary result is that the standard approach in the API standard [1] is much less accurate than CPT-based methods (ICP, UWA, Fugro, and NGI), as large model errors occur (see Table 1).

Regarding the dynamic results, it can be seen that existing p-y approaches are not always suitable for dynamic applications. In Fig. 3, the deviations of measured (using impact hammer tests of WP 7.2) and simulated eigenfrequencies (using different p-y curves) are shown. No theoretical

Table 1: Derived model errors on basis the performed pile load tests in WP 7.2

Pile load tests	Related pile capacity $Q_{\text{calculation}}/Q_{\text{measurement}}$				
	API	ICP	UWA	Fugro	NGI
Pile 1	0.42	0.84	0.78	0.96	1.91
Pile 2	0.70	1.21	1.12	1.16	2.86
Pile 3	0.47	1.00	0.93	1.23	2.09
Pile 4	0.45	0.85	0.79	0.89	1.83
Pile 5	0.50	1.07	1.02	1.30	2.28
Pile 6	0.52	0.98	0.91	1.02	2.10
Mean model error	0.51	0.99	0.93	1.09	2.18
Standard deviation	0.10	0.14	0.13	0.16	0.37
Coefficient of variation	0.19	0.14	0.14	0.15	0.17



Figure 1: Photo of the test pit and the installed piles

model can predict the correct eigenfrequencies for all tests. Although this can easily be explained, as p-y curves have originally been designed for static loads, it is an important result, since p-y curves are widely utilized in transient, dynamic wind turbine simulations.

Summary

IRPWIND successfully demonstrated the potential of European collaborations for the wind energy research. For example, the geotechnical tests in Hannover were jointly planned, designed, and conducted by LUH and the IWES Hannover and in alignment with the needs of Aalborg University. So, it was possible to use the same experiments for various subsequent numerical studies. This is just one example of successful European collaboration in IRPWIND.

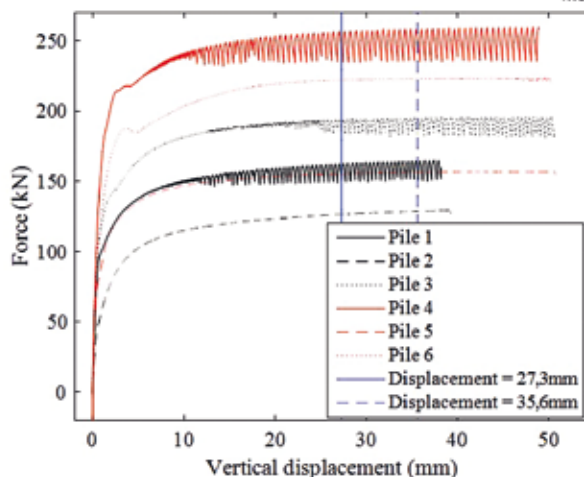

Figure 2: Raw data of the load-displacement curves for all the tensile loading tests

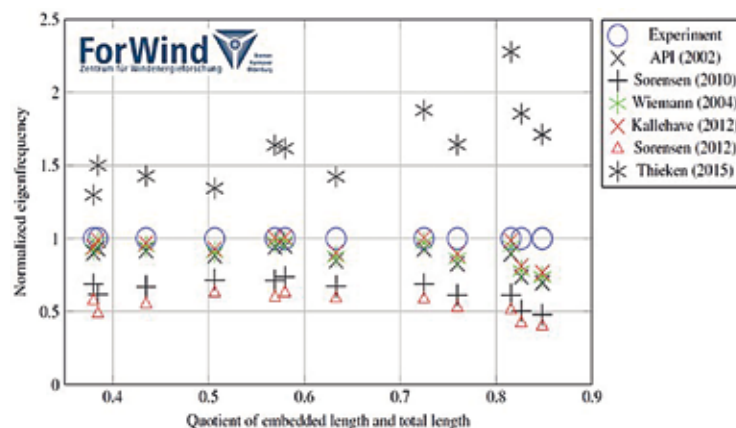

Figure 3: Normalized first bending eigenfrequencies of the piles for different embedded lengths calculated using different soil models [1-6]

References

[1] American Petroleum Institute, 2002. Recommended Practice for Planning, Designing and Constructing Fixed Offshore Platforms – Working Stress Design. Recommended Practice RP 2A-WSD

[2] Sørensen, S. P. H.; Ibsen, L. B.; Augustesen, A. H.: Effects of diameter on initial stiffness of py curves for large-diameter piles in sand. Numerical Methods in Geotechnical Engineering (2010).

[3] Kallehave, D.; LeBlanc Thilsted, C.; Liingaard, M.: Modification of the API p-y formulation of initial stiffness of sand (2012)

[4] Wiemann, J.; Lesny, K.; Richwien, W.: Evaluation of the Pile Diameter Effects on Soil-Pile Stiffness (2004).

[5] Sørensen, S.: Soil-structure interaction for non-slender, large-diameter offshore monopiles. PhD Thesis, Aalborg University Denmark (2012)

[6] Thieken, K.; Achmus, M.; Lemke, K.: A new static p-y-approach for piles with arbitrary dimensions in sand. Geotechnik 38 (2015).

Extreme Ocean Gravity Waves: Understanding and Predicting Breathers with Wave Breaking and in Coastal Waters

Carl von Ossietzky Universität Oldenburg
Institute for Physics
Research Group: Turbulence, Wind Energy
and Stochastics (TWiSt)

Ali Hadjihosseini, Christian Behnken,
Pedro Lind, Matthias Wächter,
Joachim Peinke

Partners:
Norbert Hoffmann, Technical University
Hamburg-Harburg, (Coordinator)
Efim Pelinovsky, Russian Academy of
Science, Nizhny Novgorod
Nail Akhmediev, Australian National
University, Canberra

Funding: VolkswagenStiftung

Ref.Nr. 8482

Duration: 09/2014 – 05/2019

Introduction

Oceanic rogue waves are usually defined as extremely large waves that occur suddenly and unexpectedly, even in situations where the ocean appears relatively calm and quiet [1]. While there are numerous reports from sailors claiming to have observed a rogue wave in the open ocean, rogue waves are very rare, which makes researching or forecasting difficult [2]. Because of their size rogue waves can be extremely dangerous, even to the large ocean liners, appearing in different forms of rare large-amplitude events [3,4]. As a prototypical example of extreme events emerging in a stochastic “background”, rogue waves have been investigated from various perspectives, e.g., using tools from nonlinear waves and soliton theory [5–7].

In this project, based on data from the Sea of Japan and the North Sea, the occurrence of

rogue waves is analyzed by a scale-dependent stochastic approach, which interlinks fluctuations of waves for different spacings. With this approach we are able to determine a stochastic cascade process, which provides information of the general multipoint statistics. Furthermore the evolution of single trajectories in scale, which characterize wave height fluctuations in the surroundings of a chosen location, can be determined, and time series of according wave heights can be reconstructed.

Project Description

We use a stochastic multi-point approach which is explained and discussed in [9]. For details we refer the reader to that publication. As a short summary, we describe the evolution of time series of wave heights $h(t)$ as a stochastic cascade process which evolves in the time scale $\tau = t^* - t$. Here, t^* denotes the latest time instant at which the sea level height $h^* = h(t^*)$ is to be determined. It turns out that this cascade process presents Markov properties which allow for the derivation of a closed expression of the probability of a certain height h^* to occur, namely [9].

$$p(h^* | h_1, \tau_1; \dots; h_N, \tau_N) = \frac{p(h^*)}{p(h_1)} \times \frac{\prod_{i=1}^{N-1} p(\xi_i | \xi_{i+1}; h^*)}{\prod_{i=2}^{N-1} p(\tilde{\xi}_i; \tilde{\xi}_{i+1}; h_1)} \times \frac{p(\xi_N | h^*)}{p(\tilde{\xi}_N | h_1)}$$

Here we use the short notation $\zeta_j := h^* - h_j$ for height increments. Equation (1) especially allows for the reconstruction of wave time series, incorporating correct non-linear multi-point statistics.

An example of such reconstruction is presented in fig. 1. Note the occurrence of an extreme wave height in a situation when

the according conditional probability is especially high. To quantitatively evaluate the prediction quality of our stochastic reconstruction, we apply in fig. 2 the receiver operating characteristic curve (ROC) [11, 12]. The ROC compares the rate of true predictions with the rate of false alarms for events of a given magnitude. The most quantitative index describing a ROC curve is the area under it, which is known as accuracy. In all three cases in fig. 2 we have an accuracy of greater than 80% which indicates that our multi-point procedure is a proper method for time series reconstruction and can be used for short time prediction purposes.

Summary

In this project we have presented a new approach for a comprehensive analysis of the complexity of ocean wave dynamics. We have been able to show for the first time that by our stochastic approach not only can the joint N-point statistics be grasped, but also extreme events, rogue waves, can be captured statistically. We have also shown how for each instant in time the conditional probability of the next wave height can be determined. As the height profile of waves changes from moment to moment, also the probability of the next value of the wave

height is changing dynamically. These changes may thus clearly give rise to measures indicating the risk of the appearance of rogue waves ahead of their actual emergence. Most interestingly, this was possible, although in the measured data only one event of a rogue wave was recorded. From our analysis of the occurrence probabilities it becomes clear that the rogue wave for these wave conditions is an integral part of the entire complex statistics.

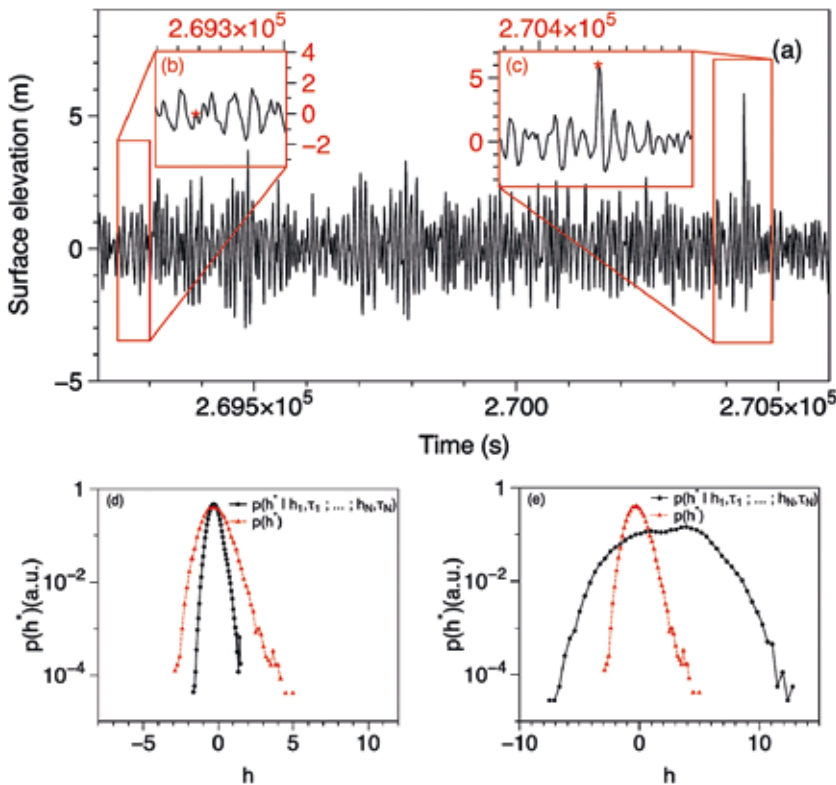

Figure 1: Reconstructed time series (a) after equation (1). Two time windows are marked by (b) and (c) for which the corresponding multi-conditioned PDFs are given in (d) and (e). To show the changing volatility of the multi-conditioned PDFs (black), the unconditional PDF (red) estimations from all data are shown too. Note the obvious changes of the likelihood of large wave amplitudes.

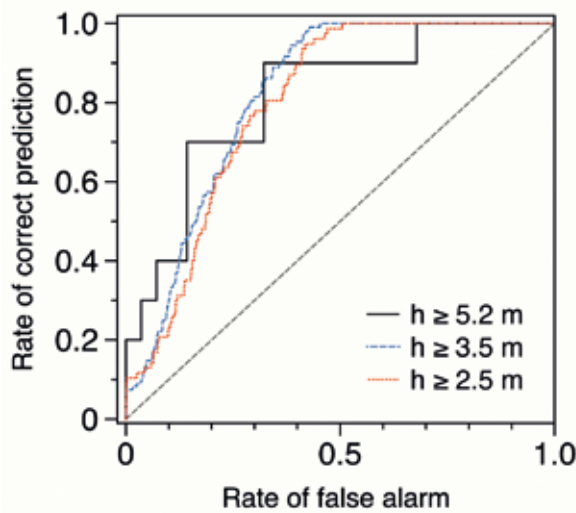

Figure 2: ROC curve for three different estimations of $P_{extreme}$, for $h_r = 5.2$ m (solid black line), $h_r = 3.5$ m (dashed blue line) and $h_r = 2.5$ m (dotted red line).

References

[1] Birkholz, S.; Brée, C.; Demircan, A.; Steinmeyer G.: Phys. Rev. Lett., 114 (2015) 213901
 [2] Soto-Crespo, J.; Devine, N.; Akhmediev, N.: Phys. Rev. Lett., 116 (2016) 103901
 [3] Kharif, C.; Pelinovsky, E.; Slunyaev, A.: Rogue Waves in the Ocean, in Springer Series in Advances in Geophysical and Environmental Mechanics and Mathematics (Springer, Berlin, Heidelberg) 2010
 [4] Onorato, M.; Residori, S.; Bortolozzo, U.; Montina, A.; Arecchi, F.: Phys. Rep., 528 (2013) 47
 [5] Remoissenet, M.: Waves Called Solitons: Concepts and Experiments (Springer) 1999
 [6] Chabchoub, A.; Hoffmann, N. P.; Akhmediev, N.: Phys. Rev. Lett., 106 (2011) 204502
 [7] Birkholz, S.; Brée, C.; Veselić, I.; Demircan, A.; Steinmeyer, G.: Sci. Rep., 6 (2016) 35207
 [8] Hadjihosseini, A.; Peinke, J.; Hoffmann, N.: Stochastic analysis of ocean wave states with and without rogue waves, New J. Phys. 16, 053037 (2014)
 [9] Hadjihosseini, A.; Wächter, M.; Hoffmann, N.; Peinke, J.: Capturing rogue waves by multi-point statistics, New J. Phys. 18, 013017 (2016)
 [10] Hadjihoseini, A.; Lind, P.G.; Mori, N.; Hoffmann, N.P.; Peinke, J.: Rogue waves and entropy consumption, Europhys. Lett. 120, 30008 (2017)
 [11] Hanley, J. A.; McNeil, B. J.: The meaning and use of the area under a receiver operating characteristic (ROC) curve, Radiology 143, pp. 29-36 (1982)
 [12] Kantz, H.; Altmann, E. G.; Hallerberg, S.; Holstein, D.; Riegert, A.: Dynamical interpretation of extreme events: Predictability and predictions Extreme Events, in: Nature and Society: The Frontiers Collection, eds. S. Albeverio, V. Jentsch and H. Kantz, Springer, pp. 69-93 (2006)

SAMS Save Automation of Maritime Systems

Carl von Ossietzky Universität Oldenburg,
Computing Science, Business Engineering

Axel Hahn

Funding: Federal State of Lower Saxony

Ref.Nr. 0325492B

Duration: 10/2014 – 09/2018

Introduction

Shipping is always a joint undertaking of humans and their technology. The increasing usage of the oceans for transportation, fishing, exploration and even recreation increase threats for humans, the environment and even the economy in case of disrupted supply chains. Consequently, the challenge faced by marine engineers and the scientific community is designing save and environment friendly maritime systems.

Project Description

In order to facilitate research in the domain of integrated and save maritime supervision, control and assistance technology, the PhD program "Save Automation of Maritime Systems (SAMS)" was approved and initiated. SAMS is a joint PhD program of the University of Oldenburg, the Jade University of Applied Science and the research institute OFFIS. It is funded by the Federal State of Lower Saxony, which provided



Figure 1: SAMS Kick-Off Meeting at the OFFIS in February 2015

funds for the granting of 15 "Georg-Christoph-Lichtenberg Scholarships" for the program in the funding period from 1 October 2014 to 30 September 2018. From approximately 200 applicants, 15 were selected on the basis of their application documents and subsequent interviews and the scholarships were awarded.

The cooperation between University of Oldenburg, the Jade University of Applied Science and the research institute OFFIS enables the combination of basic research and application perspectives with postgrad-

uate vocational training. Especially since maritime education in Germany is not carried out at university level, this cooperation makes it possible to obtain scientific doctorates for nautical science as well.

Summary

SAMS is a joint PhD program for safety of maritime systems. SAMS offers 15 three year scholarships within the period between 2014 until 2018. The objective of the program is the joint transfer of research from design and analysis technologies of safety critical systems to maritime sociotechnical systems with their specific dynamic, geographical and hydromechanical characteristics, organizational forms, technologies, environmental conditions and safety requirements.



Figure 2a, 2b: First SAMS Autumn School at the University of Oldenburg in October 2015

Ventus Efficiens – AP 3

Leibniz Universität Hannover

Institute for Drive Systems and Power Electronics
 Institute of Electric Power Systems

Farshid Goudarzi, Lutz Hofmann,
 Daniel Herwig, Axel Mertens

Funding: Lower Saxony Ministry for Science and Culture (MWK)

Ref.Nr. VWZN3024

Duration: 12/2014 – 12/2019

Introduction

Investigations of the cumulative output power of a wind park showed great power fluctuations, significantly outside the expected variance [1]. These results lead to the assumption, that the fluctuations of the single wind turbine’s output powers within the park are correlated to each other. The root cause of this phenomenon is not yet known. The topic is investigated in cooperation with the University of Oldenburg, work group Turbulence, Wind Energy and Stochastics (TWiSt).

Within the project, the problem is approached from three different points of view, with different couple-mechanisms in focus. The TWiSt investigates coupling-mechanics between wind turbines based on aerodynamics. The Institute of Electric Power Systems (IfES) addresses coupling between the wind farm and the grid based

on a numerical model of wind turbine and grid and the Institute for Drive Systems and Power Electronics (IAL) researches coupling between the converter’s control systems.

Project Description

I) Hardware-in-the-Loop (IAL)

At the IAL a test bench for detailed investigations of the converters controls is implemented. This Hardware-in-the-Loop system allows the real-time emulation of the converter controls in Matlab/Simlink. Aerodynamic coupling effects have to be simulated in condensed models.

The test bench enables the modelling of real grid configurations for a scaled output power at different voltage levels. This includes the collection grid within a wind farm. For this purpose, an overall network consisting

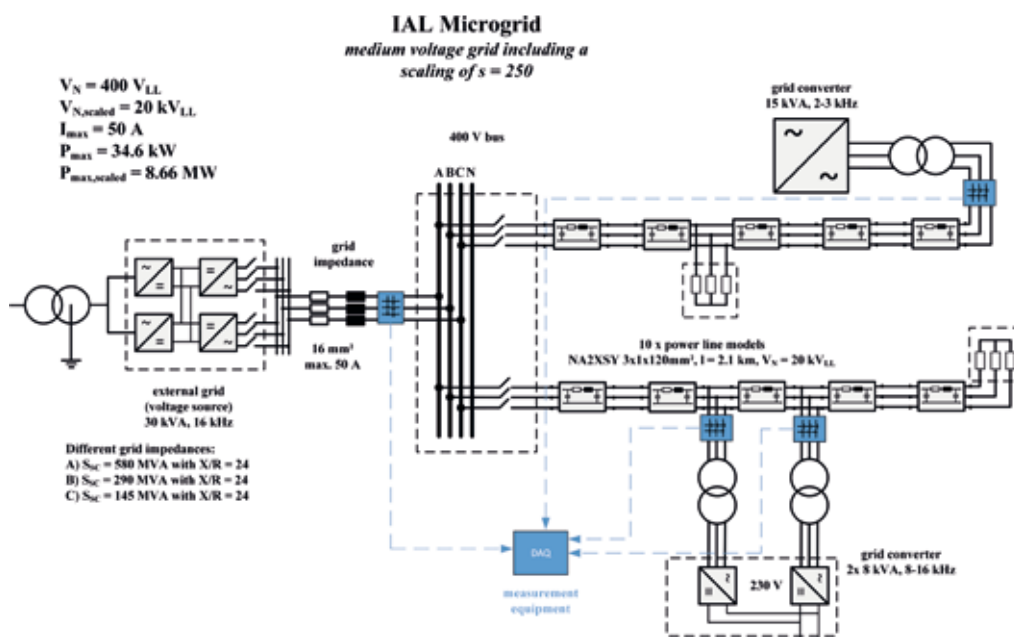

Figure 1: Example of a grid configuration with three wind turbines, a grid emulator and passive loads



Figure 2: Microgrid test bench

of several converters in the range of some ten kilowatts has been set up in the laboratory. The aim is to analyse the interactions between the individual power electronic systems as well as between the passive grid elements. Moreover, the test bench can be used to investigate alternative grid configurations and control methods for future distributed grids. An overview of the test bench is shown in Fig. 1.

The passive components between the systems are simulated by modular power line models. The initial configuration consists of ten line models (NA2XSY 3x1x120mm²) with an equivalent length of 2.1 km and 20 kV scaled output power. The models are also applicable to a low-voltage grid using NAYY 4x150mm² models with an equivalent length of 300 m. Future test bench enhancements will also include linear and non-linear loads.

The point of common coupling (classical public mains) is simulated by a converter system emulating the grid. This enables a decoupled setting of the grid parameters, e.g. frequency, harmonics or asymmetries.

The converters are able to create Matlab/Simulink models in real time mode. Apart from the electrical system, modelling of further components in the power flow chain is also possible. For example, the mechanical drive train of a wind turbine can be emulated and analysed in a simplified form for a known wind flow at the rotor blades.

A decentralized, synchronized measurement system captures the measured data with a sample rate of 10 kHz, the data being merged and depicted in a virtual system control centre. Three-phase current and voltage measurement is done for each measuring point.

As a next step, the test bench will be extended to include a 200 kVA grid-emulator. The system is driven by a real-time processor system, capable of emulating further grid components behind the PCC in Matlab/Simulink.

II) Numerical modeling (IfES)

In order to analyse the power fluctuations mentioned above, a dynamic wind farm model contains DFIG (Doubly-fed induc-

tion generator) based wind turbines is simulated in time-domain in Matlab environment. Fig. 3 illustrates the structure of overall control system of the modelled wind turbines which consists the following control concepts:

- Pitch angle and speed control
- Machine-side converter control (the independent control of the generator active and reactive power)
- Line-side converter control (the DC voltage control and the reactive current support)

In this model, the dynamic behavior of the generators and the control systems of the converters is represented through differential equation systems. According to the time frame of interest (seconds range) for the proposed investigation the passive electrical network is modelled by its steady-state model which are represented through a set of algebraic equations. Consequently, the fundamental oscillation of voltages and currents is considered through their RMS values (Root Mean Square). The resulting overall system equations can be solved for

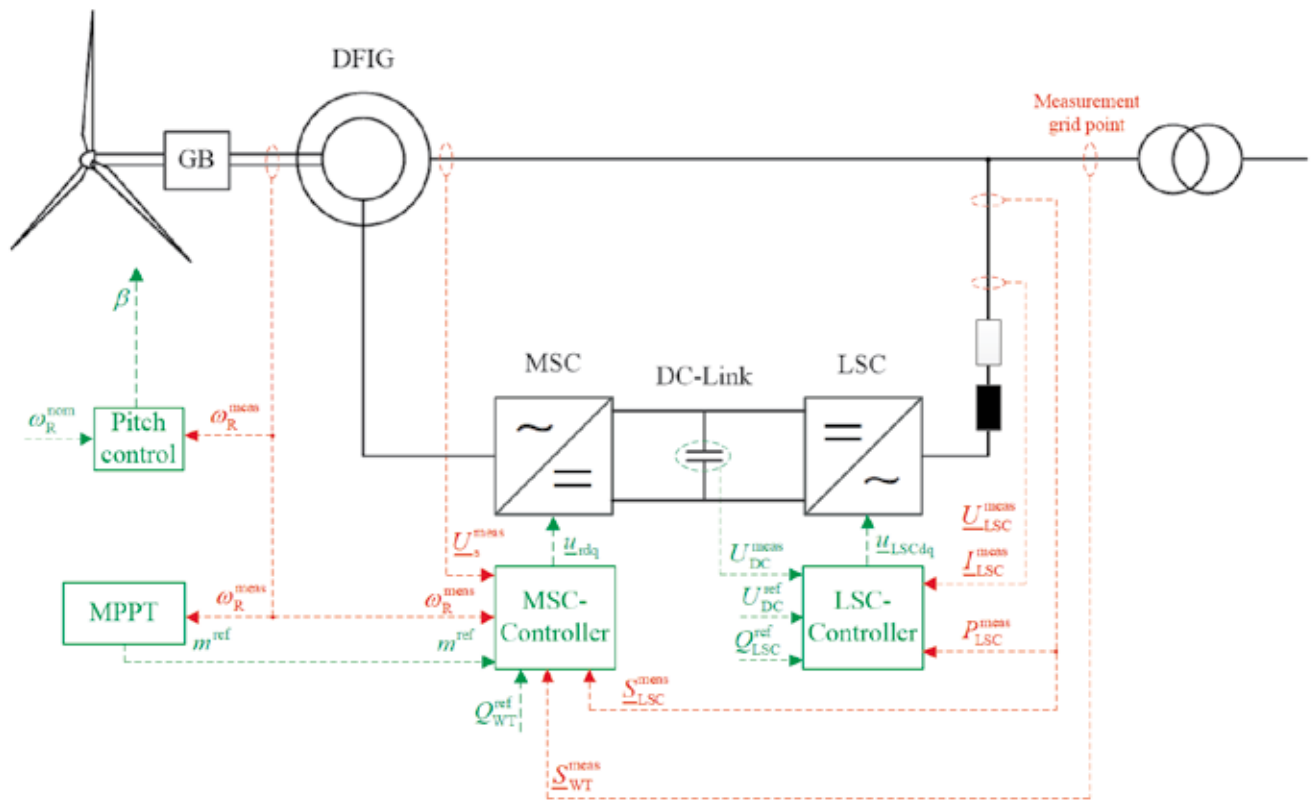

Figure 3: Structure of overall control system

each time step as an algebraic-differential equation system using an appropriate numerical method.

Summary

Within a wind park, a strong coupling of the wind turbines output power has been observed [1], that cannot be explained with coupling mechanisms known today. As the root cause is unknown, the effect is investigated with three possible origins of the coupling in focus – Aerodynamics, the power grid and the wind turbines control systems. Each study has a very detailed model of the aspect in focus and simplified models of the other two domains. The goal is to narrow down the point of origin of the observed new type of coupling between wind turbines.

References

- [1] Anvari, M.; Wächter, M.; Peinke, J.: Phase locking of wind turbines leads to intermittent power production, EPL (Europhysics Letters), Volume 116, Number 6 (2016), doi: 10.1209/0295-5075/116/60009

Ventus Efficiens – Collaborate Research to increase the Efficiency of Wind Turbines in the Energy System

Carl von Ossietzky Universität Oldenburg
Institute of Physics
Research Groups:
Energy Meteorology (EnMet),
Wind Energy Systems (WESys),
Turbulence, Wind Energy and Stochastics
(TWiSt)

Detlev Heinemann, Gerald Steinfeld,
Jens Tambke, Lüder von Bremen,
Björn Witha, Martin Kühn, Martin Kraft,
Marijn Van Dooren, Matthias Wächter,
Luis Vera-Tudela, Agnieszka Hölling,
Lars Kröger, Jannik Schottler,
Sebastian Ehrich, Lisa Rademacher,
Michael Hölling, Joachim Peinke,
David Bastine

Funding: Ministry for Science and Culture
in Lower Saxony (MWK)

Ref.Nr. ZN3024

Duration: 01/2015 – 12/2019

Introduction

The planned research activities within the framework of this project concentrate on increasing efficiency in wind energy in general and its integration into the energy supply structure in particular. The subprojects thus deal with increasing efficiency along the entire impact chain, i. e. starting with energy conversion in wind energy systems (subproject I), increasing the efficiency of load-bearing structures (subproject II) as well as drive trains and grid connection (subproject III) up to the validation of efficiency increase in the overall system of research wind turbines (subproject IV). ForWind participates with its wide variety of expertise in the subprojects I, III and IV, where each of the subprojects is again divided into work packages (WPs). For the sake of visibility the contribution of ForWind Oldenburg to each WP will be described individually in this report.

Project Description

Subproject I: Increase of the efficiency of energy conversion in wind energy systems

Work package 1: Generation and modeling of atmospheric turbulence

This WP aims at generating flow conditions that feature atmospheric like characteristics over a long test section and a large domain, respectively. This should be done for experimental investigations in the wind tunnel as well as for simulations. For the latter the Continuous Time Random Walk (CTRW) model has been used in order to generate inflow conditions that show intermittency on various scales. Currently the work focuses on stabilizing the created properties and minimizing the decay of the generated turbulence. Experimentally, a so-called active grid has been designed and constructed for the big wind tunnel with an outlet of 3m by 3m in the new WindLab building. This active grid consists of 80 motors that are connected to shafts with flaps mounted to them (see

fig. 1). Customized control protocols pre-describe the motion of each motor and with it the distribution of the blockage over the cross-sectional area of the grid over time. This procedure allows for the generation of turbulent wind fields behind the grid that feature e. g. vertical velocity profiles, different turbulence intensities, wind gusts and defined higher order statistics. To increase the basic understanding of the general correlation between motions of the shafts and the flow situations generated behind the grid, tests with other smaller active grids and reduced complexity have been performed. The results show that the basic approach for designing control protocols can be applied to all active grids independent of their size and number of motors, respectively. First tests with the big grid performed in late 2017 confirm these results. The dimensions of the new wind tunnel also allow for using LiDAR wind scanner systems in order to measure the velocity with up to 400 points per second. First test have already been performed in the wind tunnel in Milano that show the proof of this concept based on the results.

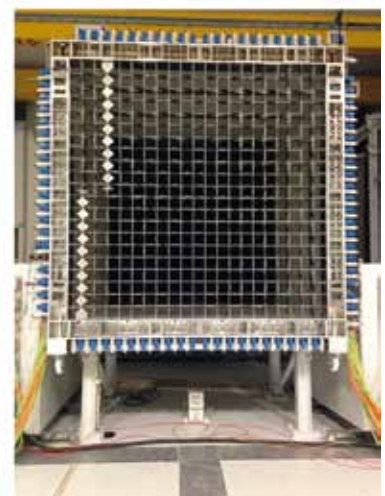
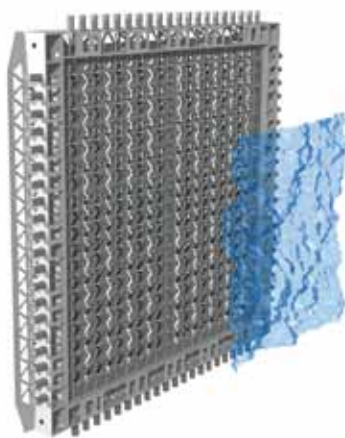

Figure 1: Left: Technical drawing of the big active grid with 80 motors. The blue field illustrates the generated turbulent wind. Right: Constructed active grid mounted to the outlet of the wind tunnel with an outlet of 3m by 3m.

Work package 2: Interaction of turbulence and wind energy systems

Experimentally, the topic of this WP has been addressed with the help of wind turbine models. Two types of turbine models of different sizes have been developed, the MoWiTO 0.6 with a rotor diameter of about 0.58m and the MoWiTO 1.8 with a rotor diameter of 1.8m (see fig. 2). MoWiTO stands for Model Wind Turbine Oldenburg. Due to the smaller size of the MoWiTO 0.6, wind farms consisting of 2 and more models can be arranged in the wind tunnel in Oldenburg. Within this project, there will be a total of eleven MoWiTOs 0.6 available for experiments, all of which feature pitch and torque control [1]. First experiments focused on measurements in the wake of such models e. g. for different inflows [2] and in yaw conditions, respectively [3]. The impact on the dynamic response of the models was investigated by creating inflow conditions with Gaussian and non-Gaussian statistics [4]. All results show, that even though the Reynolds numbers are not comparable to real wind turbines, general effects can be reproduced in the wind tunnel under controlled and reproducible boundary conditions. The larger MoWiTO 1.8 on the other hand is designed in such a way, that the local Reynolds number with respect to the chord of the rotor blades is large enough to be aerodynamically comparable to real wind turbines. Therefore, the MoWiTO 1.8 can be used to investigate the flow around the blades or even near wake characteristics, where the aerodynamic has a significant impact on the results. In order to be able to identify highly dynamic effects, which are due to the interaction of turbulent wind fields with the turbine models, stochastic methods such as Langevin processes are used and further developed within this project.

Additionally to the experimental investigations, one objective in this work package is to gain a better knowledge on the superposition of wind turbine wakes in wind farms by the use of simulation tools. The methodology chosen to achieve this objective was turbulence-resolving simulations with a large-eddy simulation model. In order to allow for the reproduction of real



Figure 2: Left: Model wind turbine Oldenburg (MoWiTO 0.6) with a diameter of 0.58m. Right: Model wind turbine Oldenburg (MoWiTO 1.8) with a diameter of 1.8m. Pictures are not in scale.

situations, the large-eddy simulation model should be driven by data from a mesoscale simulation model. In the framework of the ventus efficiens project the results of the coupling between mesoscale models and the large-eddy simulation model PALM was improved by taking information on the meso-scale advection of momentum into account in the large-eddy simulation mod-

el. This led to an improved reproduction of actually observed wind direction changes. Moreover, aiming at a verification of wind farm simulations with the large-eddy simulation model PALM, simulations of the flow conditions within the German offshore wind farm Riffgat have been carried out. A simple actuator disc model has been used to parameterize the wind turbine ef

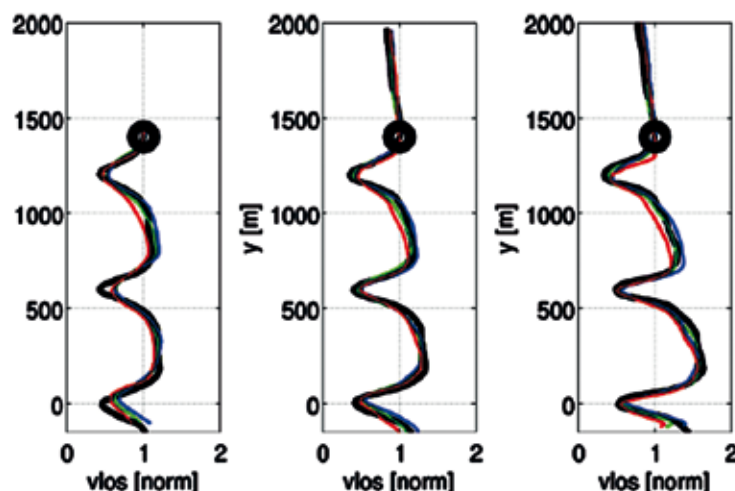

Figure 3: Line-of-sight-velocities at different positions within the wind farm Riffgat. The black line shows results obtained from large-eddy simulations with PALM, while the colored lines show actual LiDAR measurements.

fect in these simulations. The wind farm Riffgat that consists out of thirty wind turbines allows for the analysis of up to ten-fold wakes. First comparisons with data from LIDAR measurements in the farm increased the confidence in the results from the large-eddy simulations (see fig. 3).

Work package 3: Meteorological interaction of wind energy systems and feed-in
This work package aims at the promotion of ensemble forecasts as standard tool for the wind power forecast. Within this project it could be shown that different ensemble systems need different calibration methods. Generally, calibration can improve the quality of the ensemble forecast considerably [5]. Moreover, it was shown that the so-called analog-ensemble method, which is based on only one deterministic forecast run and historical data of observations and forecast runs, yield similar or even better forecast skills than conventional ensemble methods [6].

Another objective of this work package was to gain a better understanding of the reasons for the occurrence of wind fluctuations. Data from a measurement campaign and mesoscale meteorological simulations were used to investigate the impact of the atmospheric stability on wind fluctuations [7]. Moreover, the analysis of data from a large offshore wind farm in the North Sea showed that small wind direction changes come along with large power fluctuations for certain wind directions. Data from LIDAR measurements were used to investigate power fluctuations of single wind turbines.

Finally, the work package aims also at mesoscale simulations of the wind conditions around wind farms. Here, the regional impact of the planned exploitation of the wind resources in the German Bight has been studied by using the standard wind farm parameterization in the mesoscale model WRF. The results showed that clusters of offshore wind farms can have wakes that reach several tens of kilometers downstream of the cluster. The wake direction is heavily influenced by the large-scale atmospheric flow. In order to prepare a

verification of the results of the wind farm parameterization in WRF, also large-eddy simulations of the flow conditions around the cluster consisting of the wind farms Riffgrund and alpha ventus using the model PALM have been carried out.

Work package 4: Control strategies to compensate effects due to turbulence

From the experimental point of view, this WP just started since the implementation of advanced controller strategies comes after the construction and characterization of the model turbines in use. Like already reported in WP2 of this subproject, the models have been built and it has been shown that general, turbulence induced effects can be observed with these models. Next steps will focus on the further development of the controller to e. g. mitigate stochastic loads, minimize wake effects and optimize wind farm output of two and more turbines. Besides the experimental approach, one objective of this work package is a better integration of meteorological methods and information in methods for the control of wind turbines and wind farms. For that purpose a number of setups for the large-eddy simulation model PALM resulting in a variety of different atmospheric flows have been developed in the framework of the ventus efficiens project. Moreover, the wind turbine model PALM has been further developed by adding a yaw, pitch and torque controller to the ADMR wind turbine model, so that these parameters now can be used to develop new control strategies for wind turbines and wind farms. The large-eddy simulation model PALM can thus be used as a numerical test environment for the development of new control strategies.

Subproject 3: Increased efficiency of the electric drive train and the grid connection

Work package 2: Investigation of electrofluid-mechanical coupling mechanisms in wind farms

In this WP ForWind Oldenburg wants to investigate in close cooperation with the Institute for Drive Systems and Power Electronics and the Institute of Electric

Power Systems from ForWind Hannover possible coupling and synchronization effects within wind farms, respectively. The question at stake is whether such effects result from aerodynamic interaction e. g. through wakes or from electrodynamic interaction over the local electrical network. ForWind Oldenburg will address this problem by building up a wind farm of up to nine MoWiTOs 0.6 in the wind tunnel. The challenge up to now is the electrical connection between these models since the model turbines are equipped with DC motors and therefore show significantly different behavior compared to double fed asynchronous generators used in most real modern wind turbines.

Subproject 4: Validation of efficiency increases in the overall system of research wind turbines

In this subproject ForWind Oldenburg and Hannover are working together on the preparation of future measurement campaigns at the planned research wind energy plants (FWEA) to record the dynamic behaviour of the FWEA. In order to be able to evaluate influences from soil-structure interaction as well as interactions between the atmospheric flow and the operating behaviour of the FWT, ForWind institutes from the fields of wind physics (Oldenburg), civil engineering, electrical engineering and mechanical engineering (Hanover) are involved. The close interdisciplinary cooperation of the scientists leads to an improved understanding of the system and enables the use of research synergies. Subproject IV is divided into four work packages and is managed by the research group WESys (Oldenburg). At Leibniz University Hannover, the Institute for Turbomachinery and Fluid Dynamics coordinates the contributions there.

Work package 1: Coordination of measurement campaigns and technology
With the internal and external partners involved, the measurement targets, the measurement campaigns and the necessary tools were coordinated, and synergies were developed. All measurement campaigns were examined regarding permissible

and intended operation of the plant. New measurement technology and instrumentation concepts were developed for the wind turbine, which go far beyond standard instrumentation. For testing and validation of instrumentation several test sites have been developed.

Work package 2: Wind fields, aerodynamics and aeroelasticity

The overall objective of this work package is to gain a better understanding of the in-

teraction between the properties of the ambient atmosphere and the aeroelastic loads felt by a wind turbine. For that purpose the coupling between the large-eddy simulation model PALM and the aeroelastic code FAST is used. The computational requirements for coupled runs could be reduced considerably by implementing an actuator sector method in PALM. This means that in the modified version of the coupling PALM has a much larger time step than FAST.

Low-level jet events are expected to come along with large loads. Especially such situations shall be investigated with the PALM-FAST-coupling in the framework of the ventus efficiens project. PALM shall be driven by data from the mesoscale model WRF in order to produce realistic low-level jet events for the analysis. In a first step using data from a measurement campaign at the FINO1 platform it has been investigated whether the mesoscale model WRF can reproduce observed low-level

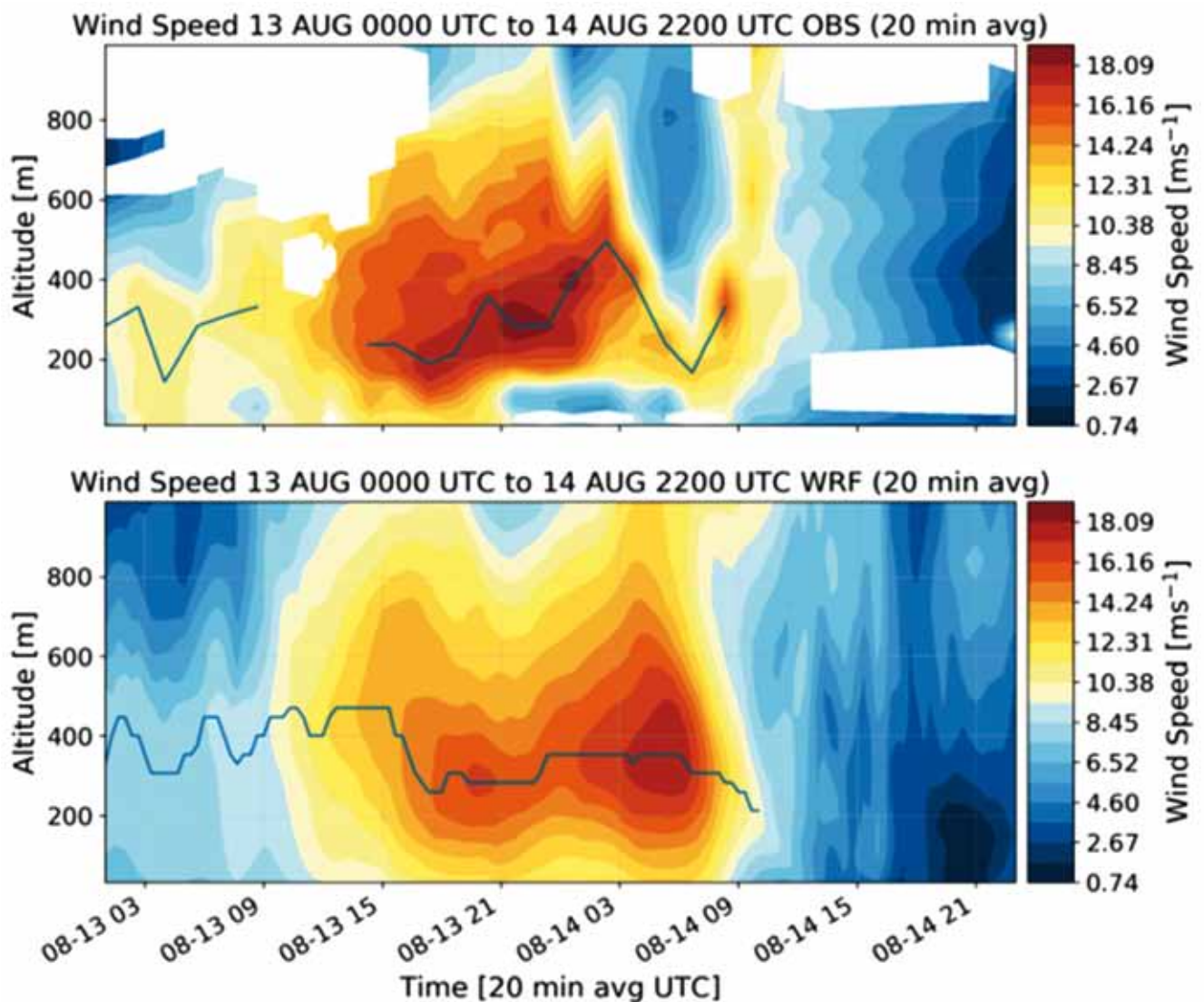

Figure 4: Wind speeds measured during a low-level jet event by a LiDAR system on the offshore platform FINO1 (top row). Wind speeds obtained from a simulation with the meso-scale model WRF for the same period of time and position as those of the LiDAR measurements (bottom row).

jet events. The result was that, generally, WRF can reproduce low-level jet events, although the intensity, the position and the timing of the low-level jet event can slightly differ between the simulation and the observation (see fig.4).

A continuous-wave short-range LiDAR with high temporal and spatial resolution recorded measurements of the rotor inflow of an eno114 turbine. For postprocessing lower order modelling of turbine inflow has been developed [8].

Work package 4: Overall system, simulation

In this work package models for describing complex wind turbine system are refined. Different approaches are pursued, which focus on the representation of the vibrational behaviour with a numerical model, the monitoring of the dynamic performance characteristics with a stochastic model and the monitoring of the fatigue load based on the transformation from standard operating data. All three priorities are intended to support the validation of existing approaches on a real-world plant and can be understood as trailblazers for the following research projects [9-12].

Summary

Within the ventus efficiens project For-Wind Oldenburg participates with simulations, stochastic analysis as well as experimental investigation. In the field of experiments much work has been done to expand the infrastructure with additional equipment and, more importantly, to gain a detailed understanding of the possibilities opening up by characterizing their performance in detail. The different wind turbine models in combination with the ability to generate user-defined turbulent inflow conditions with an active grid are the foundation for many of the upcoming tasks in this project. A combination of this to real world behaviour is given via the measurement and analysis of real megawatt wind turbines in free field.

References

- [1] Schottler, J., Hölling, A., Peinke, J., Hölling, M.: Design and implementation of a controllable model wind turbine for experimental studies, *Journal of Physics: Conference Series*, Vol. 753, No.7, 2016
- [2] Neunaber, I., Schottler, J., Peinke, J., Hölling, M.: Comparison of the development of wind turbine wake under different inflow conditions, *Progress in turbulence VII – Springer Proceedings in Physics* 196, pp. 177-182 (2016)
- [3] Schottler, J., Hölling, A., Peinke, J., Hölling, M.: Wind tunnel tests on controllable model wind turbines in yaw, *34th Wind Energy Symposium*, Vol. 1523, 2016
- [4] Schottler, J., Reinke, N., Hölling, A., Whale, J., Peinke, J., Hölling, M.: On the impact of non-Gaussian wind statistics on wind turbines – an experimental approach, *Wind Energ. Sci.*, 2, pp. 1-13, 2017
- [5] Junk, C., Delle Monache, L., Alessandrini, G., Cervone, G., von Bremen, L.: Predictor-weighting strategies for probabilistic wind power forecasting with an analog ensemble, *Meteorol. Z.*, 24, pp. 361-379, 2015
- [6] Späth, S., von Bremen, L., Junk, C., Heinemann, D.: Time-consistent calibration of short-term regional wind power ensemble forecasts, *Meteorol. Z.*, 24, pp. 381-392, 2015
- [7] Mehrens, A., von Bremen, L.: Comparison of methods for the identification of mesoscale wind speed fluctuations, *Meteorol. Z.*, 26, pp.333-342, 2017
- [8] Kidambi Sekar A.P., Kühn, M.: Lower Order Modeling of Wind Turbine inflow with Short Range Lidars, *WESC 2017*, Lyngby, Denmark [Talk]
- [9] Seifert J.K., Vera-Tudela L., Kühn M.: Training requirements of a neural network used for fatigue load estimation of offshore wind turbines, *EERA DeepWind – 14th Deep Sea Offshore Wind R&D Conference*, Trondheim, Norway [Poster & Energy Procedia]
- [10] Vera-Tudela L., Kraft M., Kühn M.: How do missing data affect your data-driven model? Monitoring fatigue loads in wind turbines with SCADA data. *Offshore Wind Energy 2017*, London, UK [Poster]
- [11] Pedro G. Lind, Vera-Tudela, L., Wächter, M., Kühn, M., Peinke, J.: Normal behaviour models for wind turbine vibrations: An alternative approach, *Energies* 10, 1944, 2017
- [12] Bastine, D., With a, B., Wächter, M. and Peinke, J.: Towards a Simplified Dynamic Wake Model Using POD Analysis, *Energies* 8, pp. 895-920 (2015)

German Research Facility for Wind Energy (DFWind)

Leibniz Universität Hannover
Institute of Structural Analysis

Raimund Rolfes, Christian Gebhardt,
Tanja Griebmann, Dorian Pache,
Benedikt Hofmeister, Stefan Wernitz

Funding: Federal Ministry for the
Environment, Nature Conservation,
Building and Nuclear Safety (BMU)

Ref.Nr. 0325492B

Duration: 03/2015 – 08/2017

Introduction

Due to the climate problem as well as environmental and resource issues, a conversion of energy systems to systems supplied sustainably with renewable energies is being pushed forward worldwide.

Wind energy plays a key role in this process in Germany, Europe and numerous other countries on the American and Asian continents. According to the International Energy Agency (IEA), a total potential of 2,300 GW should be available by 2050, which corresponds to a reduction in CO₂ emissions of 4.8 Gt per year. In recent years, the installed capacity of wind turbines (WT) has increased significantly - from 17.4 GW in 2000 to 369.6 GW in 2014 (GWEC). The German wind turbine manufacturers operating in the quality segment as well as the associated suppliers and engineering service providers are among the world's leading companies both in terms of technology standard and market share. According to Handelsblatt, five of the 15 largest manufacturers come from Europe, including all German manufacturers.

In Germany, the share of renewable energies for gross power generation is already

27.8 % (as of 2014, BMWi 2014). In order to make a contribution to reducing greenhouse gases and preventing further global warming in line with climate policy goals, the Federal Government plans to increase the share of renewable energy sources in electricity generation in Germany to 55% to 60% and 80% respectively by 2035 and 2050 respectively. Wind energy, with a total share of 34.8 % of the electricity supply from renewable energies, already plays an outstanding role today and is classified as a leader in the medium to long term.

In order to ensure the continued competitiveness of the European and German wind energy industries and to establish the use of wind energy as the cheapest form of energy, supplementary research and development efforts in the field of wind energy are necessary - as in other branches of industry (e.g. automotive, aviation). This will enable wind energy to be expanded in line with plans to increase the share of renewable energies in Germany.

In 2012, the first step towards the creation of a national research platform was taken with the start of the project "PROWind - Setting up a research wind farm" initiated by DLR, which will allow and advance a wide range of applied and basic research and developments in the wind energy sector. The construction and research operation of the platform is being promoted by DLR in close cooperation with ForWind - Center for Wind Energy Research of the Universities of Oldenburg, Hannover and Bremen and the Fraunhofer Institute for Wind Energy Systems within the German Research Alliance for Wind Energy (FVWE).

The project German Research Facility for Wind Energy (DFWind) aims to prepare and implement a worldwide unique research infrastructure. This consists of two extensively instrumented research wind turbines of the current multi-MW class (2.5 to 3.5

MW) including an extensive recording of the environmental conditions. The work in this subproject should enable the research platform to test novel components and concepts in the overall system on the one hand and to derive and improve validated industrial models for the description of large wind turbines on the other hand.

Project Description

The aim of the project is to create the basis for a wind energy research and development platform with which numerous topics for their use on land as well as at sea can be dealt with extensively and in a hitherto unattained quality along the entire impact chain. The focus will be on a holistic approach in which the research focus will be on the interaction of the subsystems in the overall wind turbine system, also taking into account the mutual influence of two separate wind turbines up to the effect on the interconnected grid. In addition to investigating purely physical and technical aspects, the structure will also be able to contribute to answering socio-economic and ecological questions relating to wind energy.

DFWind is divided into two phases for research technical upgrading. Phase 1 presented in this report serves to prepare the installation and instrumentation of the research wind turbines as well as the first meteorological measurements at the undisturbed site. This includes the development of various additional instruments in order to ensure rapid progress in the scientific upgrading of the research wind turbines after the installation of the turbines in phase 2. It is planned that this second phase will begin after conclusion of the contractual agreement with the turbine manufacturer with an overlap of several months compared to phase 1 described here.



Figure 1: DFWind research wind farm consisting of two wind turbines of the current multi-MW class and meteorological measurement masts

Global Objectives of DFWind

The overarching project objective is to answer research questions to promote the expansion and reliable operation of wind energy against the background of economic efficiency, security of supply and acceptance by the population, or to deal with questions that were previously difficult or impossible to answer. This objective can be divided into four categories:

1. Economy and Industry

The research initiative will enable the demonstration and testing of pre-competitive concepts, the implementation of which is currently still associated with an unacceptably high economic risk for industry in commercially used facilities.

2. Answering Scientific Questions

The planned extensive instrumentation

of the research platform, consisting of several wind turbines and equipment for the measurement of wind fields, noise and environmental conditions, aims at the elimination of considerable gaps in knowledge in scientific questions.

3. Use of Synergy Effects in Interdisciplinary Research

The interdisciplinary exchange is strongly promoted and the prospect of a successful economic evaluation of results is further improved by the work of the project partners with different technical orientations in the research network on the jointly operated platform. The creation of an extensive measurement and model database will enable the further development of methods and models and their validation in a holistic context.

4. Networking and Transfer

The cooperation of the FVWE partners bundles the different competences and focuses of a large research facility (DLR), a university network (ForWind) as well as an application and service oriented research institute (IWES) and thus already represents an innovative cooperation format. On this basis, an intensive networking of teaching, basic and applied research, services and innovation management takes place on a national and international level. The DFWind platform will stimulate close cooperation with other partners from science and industry, thus enable the establishment of new and improved products and services in competition, and close exploitation gaps in line with the German government's high-tech strategy.

Scientific and Technical Objectives of DFWind Phase 1

In accordance with the energy conversion chain and the technical design of wind turbines, the partners identified various working packages (WP) for phase 1 of DFWind, which is presented more detailed here:

- Elaboration of the concrete research instrumentation of the wind turbines together with the manufacturer towards the end of the project period (improved basic instrumentation, instrumentation for certification, line-guided measurement of electrical quantities of the line layout as well as power electronics, improved electromagnetic compatibility and lightning protection; Specification of the experimental turbine control; development and construction of a prototype of the data acquisition and data management system; Development of parameterized numerical component models as well as overall system models, which will later be validated in phase 2 with the acquired measurement data on rotor blade, drive train and support structure (WP 1).
- Conception, procurement, coordination and testing of the measuring instruments for far-field measurements of wind, turbulence, temperature and humidity, both for low-frequency profile and wind field measurements and for high-frequency point measurements on meteorological measuring masts; planning, procurement, coordination and testing of the acoustic measuring technology (WP 2).
- Preparation of a measurement system for monitoring the manufacture of rotor blades, in particular with regard to overall structure tests; development of structural health monitoring systems (SHM) for damage detection on rotor blades; Preparation of the aerodynamic measurement of rotor blades (pressure measurement technology, electrical and pneumatic connection concepts, protection against environmental influences, development of a mounting, mounting design for 5-hole and LIDIC probes as well as microphones on the rotor blade); development of a measurement technology for recording

the transient pressure fluctuations on the tower; sensors for recording the deformation of the blade adjustment mechanisms; processing of measurement data synchronous to the rotor position (WP 3).

- Preparation of the instrumentation of the foundation structure (for foundation movements and soil structure interaction); preparation of the measuring technique for monitoring the grouted joint between foundation and tower structure as well as for measuring the anchor forces; preparation of the instrumentation for recording the bolt forces at highly loaded locations; preparation of a measuring set-up and a concept for automated data processing and identification of dynamic parameters (modal parameters, damage parameters) of the foundation structure within the framework of long-term monitoring (WP 4).

In addition to planning the instrumentation of the wind turbines and the site, it is planned to procure and install initial instrumentation in the fields of meteorology and acoustics and in the fields of load-bearing structure and geotechnics. The reason for that is to record the yet undeveloped site in advance and thus prepare it for subsequent research projects in science and industry.

Some Scientific Results in DFWind Phase 1

Component Models

In this task models for the structural mechanical simulation of wind turbine components were generated. The theoretical basis is a theory for flexible multibody mechanics, which enables a strong coupling for structural interactions and at the same time

guarantees energy and impulse conservation. These properties are an important innovation for predicting the behavior of the complete wind turbines during operation close to their operating limits in view of the ever larger, heavier and more flexible rotor blades and tower structures of future wind turbines.

With regard to the overall project, the development should be carried out with design data of the turbines in the DFWind/PROWind measuring field. As data for these turbines is not available until the end of the project phase 1, the data set of the NREL 5MW reference turbine [1], which is widely used in the field of wind energy, was used instead. The parameterization of the models was coordinated in such a way that an update with the turbines actually installed in the measuring field is easy to implement. For this purpose, a basic support of the input format of FAST [2] was implemented.

The developed models are mechanically simplified because comparatively long time periods have to be simulated efficiently in the overall simulation. The models for rotor blade and tower described here are therefore based on a beam theory, which is state of the art in research and industry [3]. The models for foundation, drive train, nacelle and hub are based on condensed multi-body interactions.

The geometrically exact beam theory has already been successfully used in [4] for the simulation of rotor blades of wind turbines with an angle-based formulation. For this task, a formulation of the geometrically exact beam theory within the framework of a

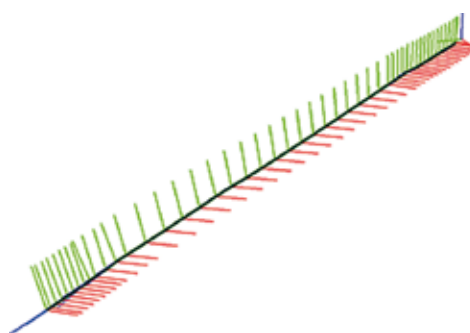

Figure 2: Illustration of a blade model with directors

director-based description of the geometry was used.

This formulation is particularly suitable in the context of large rotations as they occur in wind energy rotors. A total Lagrangian representation guarantees path independence in the transient simulation. The time integration method used has the property of impulse and energy conservation. This means that in this formulation no energy disappears due to the numerical method and rigid body movements are preserved.

The aforementioned techniques, which are implemented in an in-house simulation framework of the Institute of Structural Analysis (ISD, FW-Hannover), result in advantages in the calculation accuracy with long time scales and large changes of position of the structural components, as they occur with wind turbines.

Within the scope of this task, the multibody model and the servo components were kinematically adapted to the formulation of the beam elements, so that a consistent, flexible multibody model results when joining the components.

Overall System Models

A parameterized overall model for a wind turbine was developed on the basis of a consistent flexible multibody approach. The developed overall model forms the basis for the transient simulation of wind turbines in an aero-servo-elastic context. On the basis of the simulation results, a cost-effective and efficient dimensioning of the mechanical plant components can be carried out.

The component models developed in the previously mentioned task are combined in the overall model. The structural components are linked according to the kinematics of wind turbines by means of constraints. In addition, electrical components were developed for the overall model. A generator model provides realistic dissipation of the mechanical shaft power, a turbine controller drives the turbine to the nominal operating point and controls the angle of attack of the rotor blades.

The overall model is to be validated with the aid of measurement data from the DFWind research wind turbines. For the validation, high-resolution meteorological measurement data are available in DFWind phase 2, so that the aerodynamic load of the turbine is known precisely. High-resolution data from the turbine control system (SCADA data) enable the modelling of the aerodynamic and electrical control variables. The extensive instrumentation with accelerometers and strain gauges to determine the dynamic structural response of the wind turbine thus enables the comparison of real operation and aeroelastic simulation. A validation based on a direct comparison of the time data is aimed at, supplemented by statistical evaluations and analysis of the structural eigenmodes and eigenfrequencies.

The verification of the overall parameterized model was carried out with respect to [2]. Further, compatibility to the input data format of the FAST turbine simulation code was established. This enables a model import from this code, which is widely used in research. For the calculation of the structural dynamic response in the range of the nominal speed, in addition to the mechanical design, the exact representation of the system controller is decisive. The controller from [1] can be used for verification.

Since no model data of the turbines to be installed in the research wind farm are available yet, the models were parameterized with the data of the NREL 5MW reference turbine [1]. This data set enables the construction and calculation of a realistic model and the subsequent verification of the implementation.

Design data of the turbines in the DFWind test field can be easily entered into the parameterized models in DFWind phase 2 as soon as they become available. Based on the data set of the NREL 5MW reference turbine, a large number of publications exist, which can be used to verify the simulation code.

Operational Modal Analysis

It is of great need to identify modal properties like natural frequencies, mode shapes and damping values to understand the structural dynamical behavior of WTs. In phase 2 of DFWind those features are to be identified and monitored for the WT support structure and rotor blades, respectively. These parameters form the basis for the adaptation of numerical simulation models and at the same time represent an important component of structural health monitoring. It is well known that modal parameters vary as a function of changing environmental

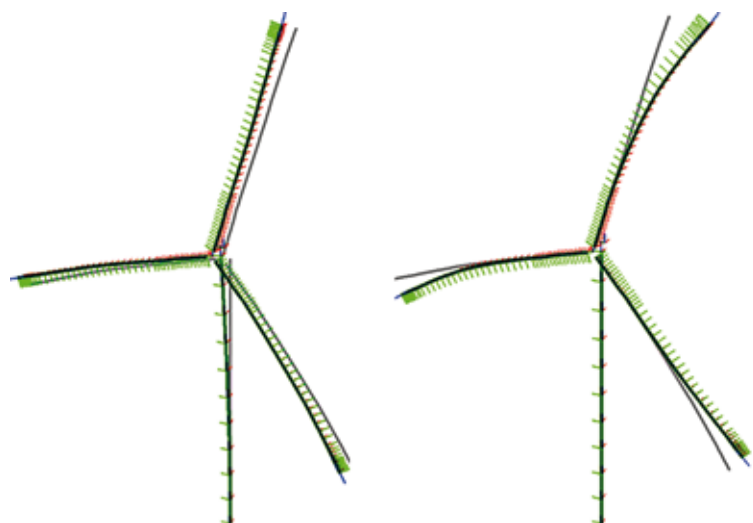

Figure 3: First mode shape of support structure (left) and first mode shape of rotor blades (right)

and operational conditions (EOC). However, varying modal parameters within the same operating conditions can be damage indicators. In DFWind operational modal analysis (OMA) is carried out using acceleration measurements. Therefore, preliminary modal testing was performed on a swept pre-stressed concrete support structure in a laboratory setup.

The tower consists of twelve ring-shaped reinforced high-strength concrete segments stacked on top of each other, each 5 cm thick, 60 cm in outer diameter and 0.5 m high. The total height is approximately 6.67 m together with the tensioning structure at the top of the tower. The tower has a cylindrical structure with a cylindrical profile. The stability of the tower is provided by a pre-stressed single tendon, which is anchored in the foundation and runs centrally through the tower up to a 460 kg head construction.

As a system identification technique the Covariance-Driven Stochastic Subspace Identification (SSI-Cov) was considered [5]. The resulting eigensolutions were evaluated or with other words identified as modal properties using the triangulation based extraction of modal parameters method (TEMP) [6]. Instead of simulating the change of modal parameters due to environmental variability, different damage scenarios were considered. Those were realized by performing saw cuts between the concrete segments at different positions and depth. In a monitoring scenario, the number of identified modes varies across the data sets. This makes it difficult to monitor the modal parameters of different system states (under different EOCs) and/or different measurements. The reasons is that it is not possible to compare the i th eigensolution in the reference state or in the one data set with the i th eigensolution in the next system state or other data set. In addition, the eigenfrequencies change their values as the degree of damage increases due to the reduction of stiffness. In case of the laboratory test, an attempt was made to compute the MAC value and frequency deviation in order to trace the course of the natural frequencies over the individual structural states. This proce-



Figure 4: Pre-stressed concrete support structure equipped with accelerometers in a laboratory setup

cedure is based on the assumption that the local structural changes solely slightly effect those properties.

Structural Health Monitoring

The condition monitoring of structures can be divided into four or five general phases [7], [8]: 1. damage detection, 2. damage localization, 3. damage classification, 4. damage quantification and 5. lifetime prognosis. Purely measurement data and vibration-based approaches that do not use structural models (e.g. FE models) can only cover the first two phases of SHM. The decision whether and where the monitored structure is damaged is usually made by evaluating damage sensitive features, also called condition parameters (CP) [9]. All quantities that can be derived directly (e.g. maximum values) or indirectly (e.g. natural frequencies) from the measurement data are described as such. Absolute and relative CPs exist. The former can be determined by looking at a single data set. These include natural frequencies or damping values. Relative CPs in turn result from the application of a comparison metric to two or more data series. The feature tested describes the average power of a synthetic difference pro

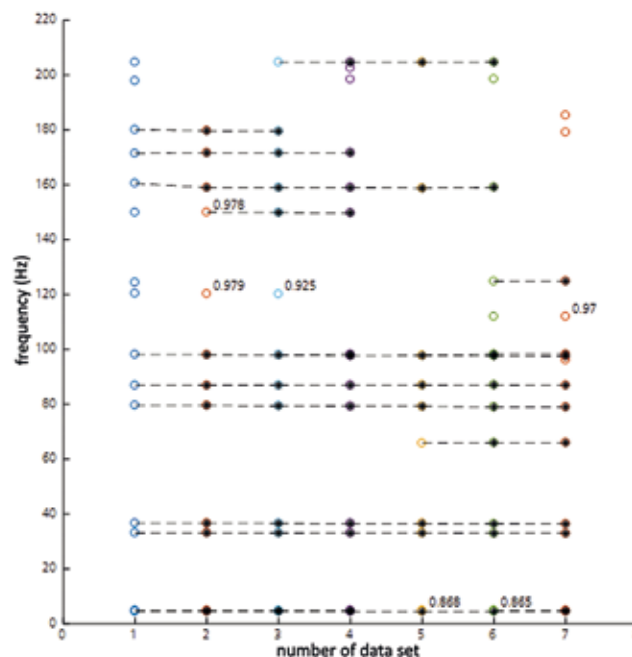

Figure 5: Monitoring of identified natural frequencies and mode shapes (dashed line)

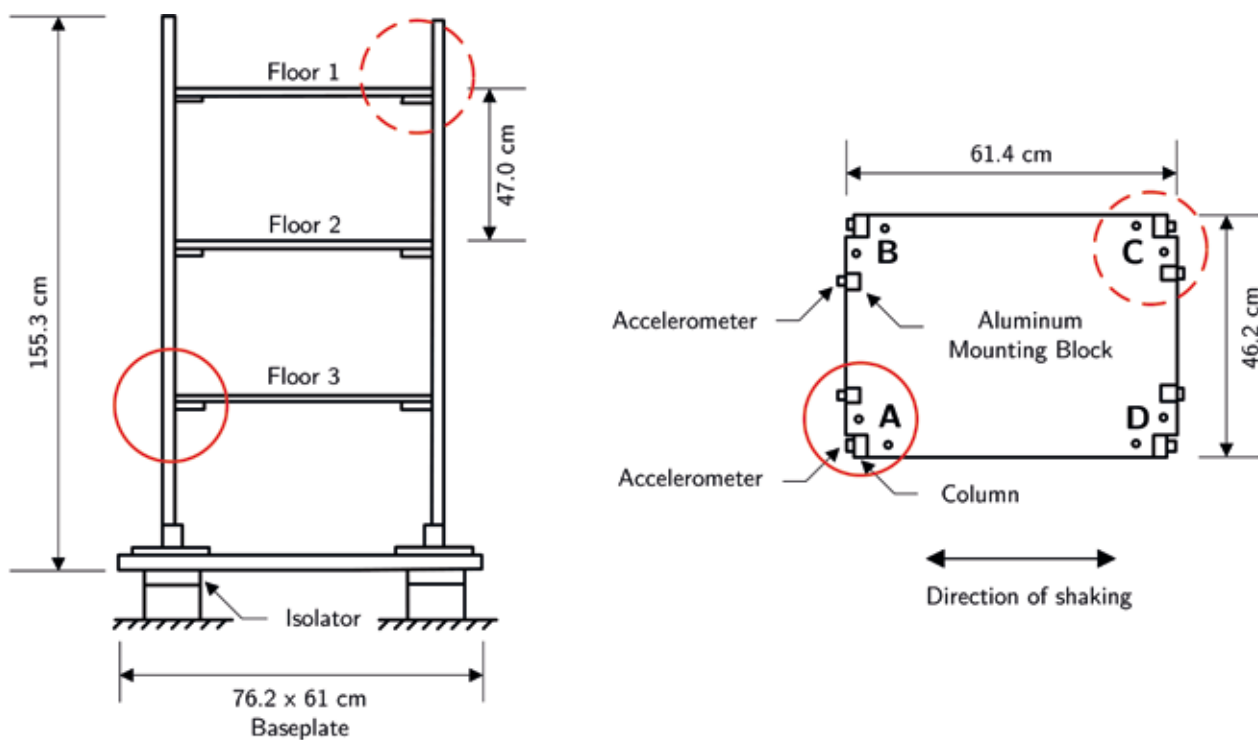

Figure 6: Experimental setup and damage positions (circled) of the benchmark test on a three-story frame structure

cess (relative quantity) and can be used for damage detection and localization as well. Prof. Armin Lenzen and Dr. Max Vollmering from the University of Applied Sciences in Leipzig defined the examined CP based on H_∞ estimation and state projections [10], [11]. It was applied in DFWind phase 1 using benchmark test data provided by the Los Alamos National Laboratories [12]. The measurements were performed on a three-story frame structure under laboratory conditions.

Apart from measurements in the reference state (undamaged), five different damage scenarios were realized on two different positions and data acquired. Bolts between brackets and plates were loosened (scenario D05, D10, DHT) and removed (scenario DB0). The removal of entire brackets was the most severe damage state (scenario DBB). The damage analysis showed that all structural modification were detected and most scenarios located. Therefore, the proposed condition parameter showed a promising potential for future SHM and damage assessment in DFWind phase 2.

References

- [1] Jonkman, J.; Butterfield, S.; Musial, W.; Scott, G.: Definition of a 5-MW Reference Wind Turbine for Offshore System Development, Golden, Colorado: NREL, 2009.
- [2] Jonkman, J.; Buhl, L. M.: FAST User's Guide, NREL, 2005.
- [3] Wang, Q.; Jonkman, J.; Sprague, M.; Jonkman, B.: BeamDyn User's Guide and Theory Manual, NREL, 2016.
- [4] Wang, Q.; Sprague, M.; Jonkman, J.; N. Johnson, N.; Jonkman, B.: BeamDyn: a high-fidelity wind turbine blade solver in the FAST modular framework, *Wind Energy*, vol. 20, pp. 1439-1462, 2017.
- [5] Katayama, T.: Subspace methods for system identification, Springer, 2005.
- [6] Häckell M. W.; Rolfes, R.: Monitoring a 5MW offshore wind energy converter - condition parameters and triangulation based extraction of modal parameters, *Mechanical Systems and Signal Processing*, vol. 40, no. 1, pp. 322-343, 2013.
- [7] Rytter, A.: Vibration based inspection of civil engineering structures, Aalborg: Dept. of Building Technology and Structural Engineering, Aalborg University, 1993.
- [8] Farrar, C. R.; Worden, K: Structural health monitoring: a machine learning perspective, Chichester, West Sussex, U.K. Hoboken, N.J: Wiley, 2013.
- [9] Häckell, M. W.: A Holistic Evaluation Concept for Long-Term Structural Health Monitoring, *Mitteilungen des Instituts für Statik und Dynamik der Leibniz Universität Hannover* 25/2015, 2015.
- [10] Lenzen, A.; Vollmering, M.: An output-only damage identification method based on H_∞ theory and state projection estimation error (SP2E), *Structural Control and Health Monitoring*, 2017.
- [11] Lenzen, A.; Vollmering, M.: On experimental damage localization by SP2E: Application of H_∞ estimation and oblique projections, *Mechanical Systems and Signal Processing*, vol. 104, pp. 648-662, 2018.
- [12] Wernitz, S.; Pache, D.; Griebmann, T.; Rolfes, R.: Performance of an H_∞ estimation based damage localization approach in the context of automated Structural Health Monitoring, 9th European Workshop on Structural Health Monitoring, 2018.

Smart Blades 2 – Construction, Testing and Further Development of Intelligent Rotor Blades

Carl von Ossietzky Universität Oldenburg
Institute of Physics
Research Group: Wind Energy Systems
Research Group: Turbulence, Wind Energy and Stochastics

Lars Neuhaus, Piyush Singh,
Agnieszka Hölling, Michael Hölling,
Martin Kraft, Martin Kühn,
Joachim Peinke, Hamid Rahimi,
Marijn van Dooren, Lena Vorspel,
Bastian Dose, Frederik Berger,
Vlaho Petrovic, Mohsen Forghani,
Matthias Wächter, Stephan Voß,
Róbert Ungurán

Leibniz Universität Hannover,
Institute of Structural Analysis,
Institute of Turbomachinery and Fluid
Dynamics,
Institute for Wind Energy Systems

Mehdi Garmabi, Ayan Haldar,
Eelco Jansen, Helge Jauken,
Hinesh Madhusoodanan, Raimund Rolfes,
Christoph Jätz, Jörg Seume, Torben Wolff,
Claudio Balzani, Tobias Holst, Sina Lotfi-
omran, Pablo Noever Castelos,
Jelmer Derk Polman, Andreas Reuter,
Michael Wentingmann

Funding: Federal Ministry for Economic
Affairs and Energy (BMWi)

Ref.Nr. 0324032C (ForWind Hannover)
0324032D (ForWind Oldenburg)

Duration: 09/2016 – 11/2019

Introduction

As wind turbines continue to grow in size, the slenderness of wind turbine rotor blades increases. Hence, the loads acting on wind turbines and their components become increasingly critical. The SmartBlades2 project aims to reduce the aerodynamic loads and their fluctuations without significantly

affecting the energy yield. Different smart blades technologies are being investigated, components are being designed and tested and simulation models are in course of validation at different scales, including field tests. In addition to the partners from the forerunner project “Smart Blades” comprising the ForWind research institutes, the German Aerospace Center (DLR) and the Fraunhofer Institute for Wind Energy Systems (IWES), several partners from the wind energy industry joined the consortium, namely General Electric Deutschland Holding GmbH, Henkel AG & Co. KG, Nordex Energy GmbH, SSB Wind Systems GmbH & Co. KG, Senvion GmbH, Suzlon Energy Limited and WRD Wobben Research and Development GmbH. ForWind is participating with its wide variety of expertise in all project activities, which are divided into four technologies.

Project Description

Technology 1 – Rotor blades with bend-twist coupling

In this technology, 20 m rotor blades with a passive bend-twist coupling were manufactured by DLR for a full-scale blade test at Fraunhofer IWES and for field tests on the CART 3 research wind turbine at the National Renewable Energy Laboratory (NREL) in Boulder, Colorado, USA. These tests should provide the consortium with the necessary data to validate codes, tools and models developed in the previous Smart Blades project. For this purpose ForWind was involved in the definition of sensor positions in the full-scale blade test and the specification of test cases that must be covered in the field tests. The developed simulation tools have been fed with the CART 3 geometry. CFD grids as well as Finite Element models for the 20m blades have been prepared. Additionally, ForWind is responsible for measuring the CART 3 wind turbine’s incoming wind field, which is

achieved by using a continuous-wave short-range LiDAR system. The LiDAR measures on a conical area around the nacelle top at a distance of 60 m in front of the rotor. Besides the testing activities, strategies to include structural bend-twist coupling in addition to those worked on in the forerunner project are being studied at an 80 m scale. A parametric study on helical stringer configurations has started, aiming to find a weight-specific optimum solution for the integration of structural bend-twist coupling.

Technology 2 – Rotor blades with active trailing edge

The main goal of ForWind Oldenburg in Technology 2 is to build up a new setup for validating the aerodynamic and servodynamic performance of a profile with an active trailing edge. The idea is to expose such a profile to varying inflow conditions coming from pre-defined time changing angles of attack at the leading edge of the profile. The resulting forces will be measured and controlled using the active trailing edge. ForWind Oldenburg has been modified in order to be able to meet the requirements for the needed inflow conditions. First tests have been done and these inflow conditions have been characterized.

The activities of ForWind Hannover are subdivided into structural, aeroelastic, aeroacoustic investigations and model development. In the structural part, the fatigue behavior of segments with an active trailing edge that are cyclically tested at DLR, are simulated using a fatigue model implemented in ABAQUS. For that purpose the related finite element models were created, see Fig. 1. The aim is to apply and validate within SmartBlades2 the fatigue damage model that has recently been extended to 3D stress states. In addition, an active trailing edge based on the concept of multi-stable structures is investigated. Therein, a bi-stable structure was designed to switch between the required maximum flap de

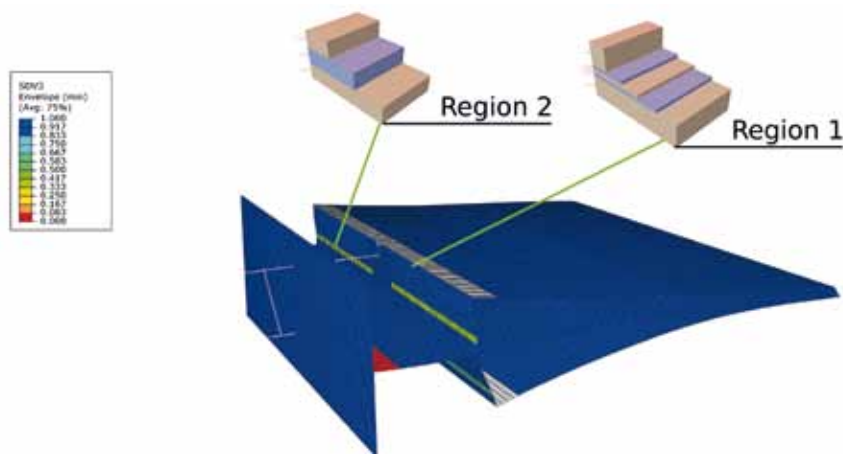

Figure 1: Fatigue simulation for flexible trailing edge under representative variable amplitude fatigue loading.

flections with low energy consumption via piezo actuators. Finite element simulations have been carried out in order to show the feasibility of the concept [1].

In the context of aeroelasticity, ForWind Hannover implemented an empirical aerodynamic model based on URANS simulations. The model was developed with the aero-servo-elastic simulation tool FAST in the forerunner project. It is planned to validate this model by means of 2D wind tunnel experiments within the project at a later stage. Besides, the development of a high-fidelity aero-servo-elastic model with two-way coupling between the structure and aerodynamics has started. A shell-type (“3D”) finite element model represents the structure, the aerodynamic model is based on BEM, and the controller for torque-speed and pitch control relates the rotor behavior to the wind inflow.

Moreover, ForWind Hannover aims to perform high-fidelity CFD/CAA aeroacoustic simulations. For that purpose, a parameterized CAD model of the specimen geometry that has been tested in the forerunner project has been created. The meshing of the fluid volume with CCM+ has started, so that remeshing for variable flap angle configurations will be possible in the near future. A literature review resulted in the decision to use DDES, a hybrid RANS/LES method

that appropriately resolves the different scales at a reduced computational cost compared with a pure LES approach.

Technology 3 – Rotor blades with adaptive slat

The encouraging result in the previous Smart Blades project regarding Technology 3 led to an extended consideration in Smart-Blades2. This includes the active slat, a rigid version of the slat as well as a so-called passive adaptive slat, equipped with a kinematic that allows the slat to move in a predefined manner based on local inflow conditions. In this technology ForWind Oldenburg is involved in wind tunnel test with the active and the passive adaptive slat. For the active slat an open as well as a closed loop control strategy are being tested and compared with respect to the ability to mitigate force fluctuations. In the closed loop control the movement of the slat is based on the acting forces on the profile whereas the open loop control uses the previously measured information of the evolution of the inflow conditions. In contrast to the Smart Blades project where just sinusoidal variations of the inflow angle have been tested, more complex flow situations are planned for this project. So far different controller concepts have been investigated as well as the communication set-up with the active slat electronics and mechanics. The active grid has been characterized in detail and a transfer matrix that allows for

designing the pre-defined complex inflow situations has been measured. In close cooperation with DLR the specifications for the kinematics for the passive adaptive slat have been defined. In the field of the rigid slat, ForWind Oldenburg is mainly interested in the effect of a rigid slat on the dynamic response of a wind turbine. Stochastic analysis using Langevin processes will be used to investigate e. g. the dynamics of the power output of a wind turbine with and without a rigid slat under realistic inflow conditions. This will be achieved with data from a real multi MW wind turbine from the project partner Suzlon, which will be equipped with a rigid slat. Additionally, in this project ForWind Oldenburg designed and built a model turbine for wind tunnel experiments. Fig. 2 shows the Model Wind Turbine Oldenburg, which has a diameter of 1.8 m (MoWiTO 1.8). The size of the blades is large enough so that aerodynamically functional slats can be designed and constructed for it. The turbine is equipped with sensors to measure, among other things, torque, power output, rotational frequency, thrust and bending moments of the blades. The system features a torque control and three motors allow for individual pitch control. This turbine will be tested under various inflow conditions in the turbulent wind tunnel in Oldenburg. This wind tunnel is equipped with an active grid (see fig. 2) that allows generating flexible inflow conditions featuring e. g. different turbulence intensities and higher order statistics. The inflow situations for the wind tunnel tests have been designed and the active grid performance has been characterized. Additionally, ForWind is also involved in the acoustic analysis of the slat technology. Currently, the validation of the numerical models regarding the acoustic simulations is being performed.

Technology 4 – Cross-Technology Topics

Activities at ForWind Hannover that cannot be linked directly to a single investigated technology but to all are integrated in the cross-technology topics. These comprise the modeling and simulation of adhesive joints, the investigation of aero-elastic stability (flutter) and the further evaluation of techno-economical aspects of each technology.

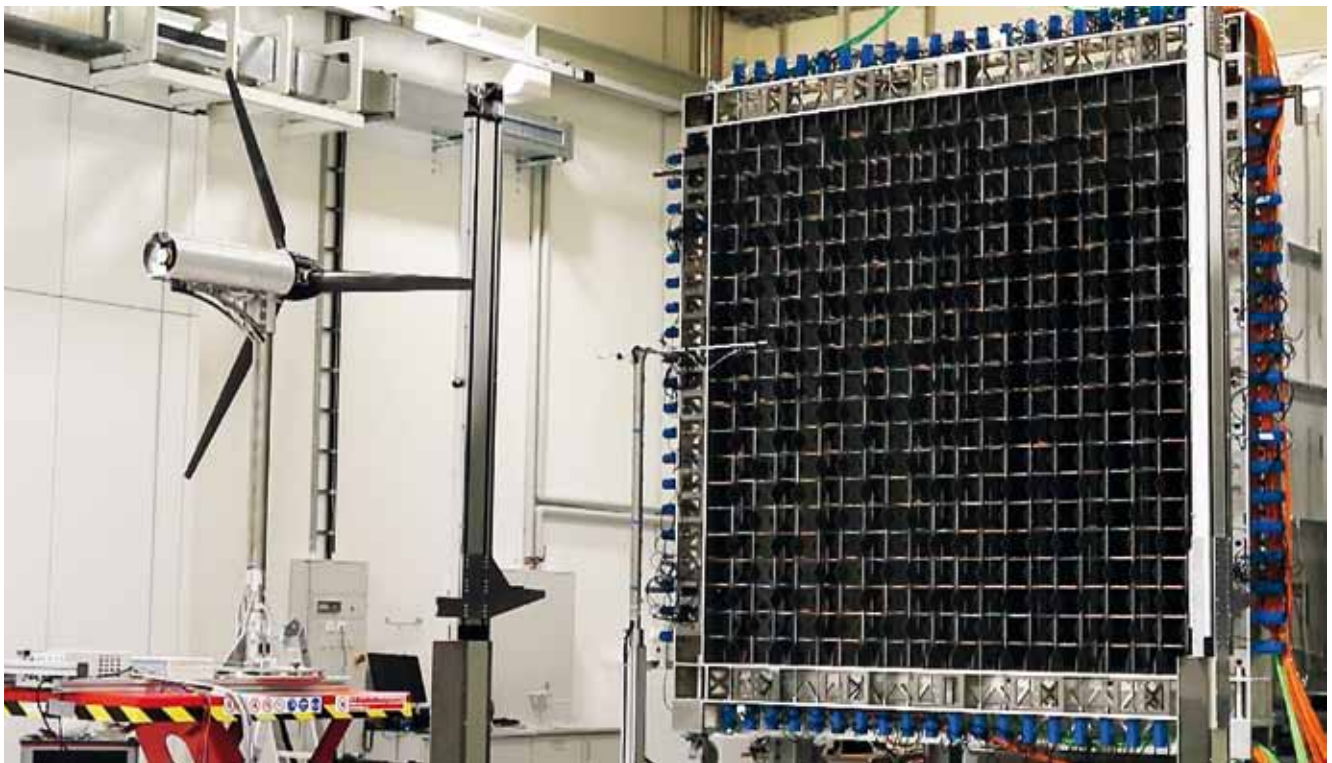

Figure 2: Model Wind Turbine Oldenburg with a diameter of 1.8m (MoWiTO 1.8) in front of the active grid in the big wind tunnel in Oldenburg

In the work package focused on adhesive joints, trailing edge adhesive joints have been added to the finite element modeling process developed in the in-house tool MoCA (Model Creation and Analysis tool) and including local mesh refinement, see fig. 3 (a)-(b). The adhesive is modeled with

solid elements in order to extract full 3D stress states, see fig. 3 (c). Global stress calculations show clear 3D stress states in the adhesive, highlighting that the commonly used one-dimensional shear stress proof is physically not meaningful [2-4]. The modeling of the curing kinetics is finished and

measurements of the thermal and chemical shrinkage have started.

For the investigations of flutter limits of different smart blades technologies, the setup of FAST models of the Smart Blades reference turbine has started. The structural

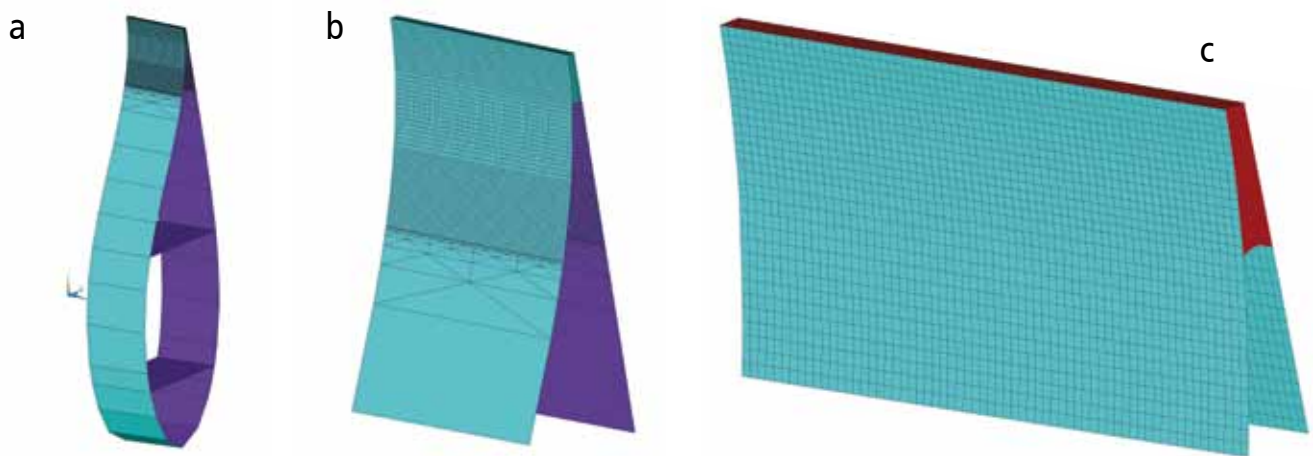

Figure 3: Finite element model of the trailing edge adhesive joint. (a) Slice of the blade, (b) detail of the trailing edge with local mesh refinement, (c) hybrid shell/solid element model at the trailing edge with the adhesive solid elements highlighted in red.

properties for the beam model have been recalculated on the basis of the 3D blade model from the forerunner project. Pre-test simulations for a code-to-code comparison with project partners have jointly been specified. These will start in the near future.

The technology evaluation model has been reviewed and improvement potential has been identified. The technology evaluation will be executed in regular time intervals in order to identify development needs throughout the project. A final evaluation aims for the comparison of the effectiveness of the different technologies.

Summary

The project is running and the partners are working on fulfilling their ambitious goals. ForWind is active in the development of all the project's technologies, including structural investigations on bend-twist coupled blades, wind field and wind tunnel measurements, structural, aeroelastic, and aeroacoustic modeling as well as the techno-economic technology evaluation. First results are already available, but the major results are expected towards the end of the project at the end of 2019.

References

- [1] Haldar, A.; Jansen, E.; Rolfes, R.: Snap-through of Multistable Variable Stiffness Composites using Piezoelectric Actuators, in: Ferreira, A. J. M.; Larbi, W.; Deu, J.-F.; Tornabene, F.; Fantuzzi, N. (Edts.): Proc. of ICCS20 – 20th International Conference on Composite Structures, Sept. 04-07, 2017, doi: 10.15651/978-88-938-5041-4
- [2] Noever Castelos, P.; Voosen, M.; Balzani, C.: Non-proportional multi-axial stress states and their influence on the fatigue life of trailing edge adhesive joints in wind turbine rotor blades, Wind Energy Science Conference, Technical University of Denmark, Lyngby Campus, Copenhagen, Denmark, June 26-29, 2017
- [3] Noever Castelos, P.; Wentingmann, M.; Balzani, C.: Fatigue analysis of trailing edge adhesive joints in wind turbine rotor blades accounting for non-proportional multiaxial stress histories, in: Ferreira, A. J. M.; Larbi, W.; Deu, J.-F.; Tornabene, F.; Fantuzzi, N. (Edts.): Proc. of ICCS20 – 20th International Conference on Composite Structures, Sept. 04-07, 2017, doi: 10.15651/978-88-938-5041-4
- [4] Noever Castelos, P.; Wentingmann, M.; Balzani, C.: Comparative study of finite-element-based fatigue analysis concepts for adhesive joints in wind turbine rotor blades, Proceedings of the 7th GACM Colloquium on Computational Mechanics for Young Scientists from Academia and Industry, Stuttgart, Germany, Oct. 11-13, 2017

Interdisciplinary Research Center on Critical Systems Engineering for Socio-Technical Systems II

Carl von Ossietzky Universität Oldenburg,
Research Center Safety Critical Systems /
Computing Science, Business Engineering

Axel Hahn

Funding: Federal State of Lower Saxony
and Volkswagenstiftung

Duration: 01/2017 – 10/2018

Introduction

Critical Systems, i.e., systems whose failure either endanger human life or cause drastic economic losses, form the technological backbone of today's society and are an integral part in such vastly diverse industrial sectors as automotive, aerospace, maritime, automation, energy, health care, banking, and others.

Project Description

The Project "Critical Systems Engineering for Socio-Technical Systems II" (CSE-2) is funded by the 'Volkswagenstiftung' and the MWK from January 2017 to October 2018. Building on the successful work of the predecessor project CSE-1, the project's objective combined goals on a technical research level as well as on a strategic level, summarized as 'enhancing the state of the art of human-centered critical systems engineering and increasing the visibility of the state of Lower Saxony as one of the main actors on national and European level in this interdisciplinary research area with high social relevance'.

CSE-2 focuses on instances of such socio-technical systems in the transportation domain, where the overarching objectives are to achieve safe and green mobility, through cooperative semi-autonomous guidance of vehicles with humans in the loop, such as in their roles as drivers, operators, navigation officers, flight controllers, etc., and consider two industrial sectors key in Lower Saxony, the automotive and maritime domains. Such systems are safety critical – human errors, technical failures and malicious manipulation of information can cause catastrophic events leading to loss of life. Creating sufficiently precise real-time mental or digital images of real-world situations and assuring their coherence among all involved actors (both humans and technical systems) as a basis for coordinated action is a major challenge in socio-technical system design. This calls for constructive approaches involving intuitive and scalable patterns of cooperation, between humans and technical systems, seeking for a balanced sharing of tasks best matching both the abilities of humans and technical systems, or between technical systems. It calls for insights in understanding humans in their interaction with technical systems. It calls for layered approaches in aggregating information

along both spatial-temporal and cognitive dimensions. It calls for robust and adaptable designs, seamlessly catering with adverse and changing environmental conditions. It calls for executable and composable models of socio-technical systems, both human and technical, allowing to adaptively, as it were, "zoom" into detailed levels when reaching critical states to provide fine-grained views of the actual interactions, as well as the need to aggregate to coarse views in order to cope with the sheer complexity of such models.

To aid the strategic impact of the project, CSE-2 has been structured into two main research areas, namely:

- A. foundational research of the principles of Human-Machine Cooperation in safety critical real time systems, paving the way for a submission of a proposal for a collaborative research center at the German Science Foundation
- B. establishing a research infrastructure which is unique in Europe for experiments and experimental evaluation in the scope of CSE.

Summary

The Interdisciplinary Research Center on Critical Systems Engineering for Socio-technical Systems addresses critical systems, which rely on synergistically blending human skills with IT-enabled capabilities of technical systems to jointly achieve the overarching objectives of the system-of-systems.

Continuing Studies Programme

Wind Energy Technology and Management (“Windstudium”)

Moses Kärn and Christoph Schwarzer

Partners:
Wind Energy Agency WAB,
City of Oldenburg

Funding: Participants’ fees and co-sponsoring by Norddeutsche Landesbank (NORD/LB), GE Wind Energy GmbH, UKA Umweltgerechte Kraftanlagen GmbH & Co. KG

Introduction

In the years 2015, 2016, and 2017 the *Continuing Studies Programme Wind Energy Technology and Management* (“Windstudium”) started with its 10th, 11th, and 12th one-year-long courses. The Windstudium has maintained its unique position as part-time qualification for professionals despite the fact that the wind energy businesses have been facing uncertain regulatory standards and policies in the year 2013 and following (e. g. debates about the “Strompreisbremse” and replacing the fixed feed-in-tariffs by an auction process with the EEG 2017). The Windstudium is still operated by the founding institutions ForWind, WAB in close cooperation with the City of Oldenburg, and the companies GE Wind Energy GmbH, Bremer Landesbank (now NordLB), and UKA Umweltgerechte Kraftanlagen GmbH & Co. KG.

Project Description

Wind energy is a highly innovative and interdisciplinary industry sector whose further successful development is closely tied to the availability of highly skilled and educated experts from various backgrounds. Because of the complex nature of the field part-time education is an important instrument to provide professionals with high-level systematic know-how and interdisciplinary understanding of wind energy technology, projects, and economic issues.

The *Continuing Studies Programme Wind Energy Technology and Management* is especially designed to support companies of the wind energy sector and is directed to professionals in the field as well as to those who wish to enter this field. It offers comprehensive systematic understanding of wind energy projects from scientific grounds to technical, legal and economic realization, as well as skills in planning and project management.

The programme offers a mix of learning methods and is therefore designed to fit the requirements of professionals: self-study of reading materials, a two-day seminar once every month, and project work in teams. The total duration of the programme is eleven months. The Diploma of Advanced Studies (DAS) “Certified Wind Energy Expert” is issued by the University of Oldenburg upon successfully passing the examinations.

The realization of wind energy projects requires that experts from a variety of different disciplines work closely together. The “Windstudium” addresses exactly such interdisciplinary challenges, and fosters a ‘know-how-transfer’ from acknowledged experts in the field and from Universities, thus providing current and expert knowledge. The program’s study materials were developed in partnership with the University of Oldenburg’s continuing education

experts and satisfy the highest of academic didactic standards.

The interdisciplinary approach is the central theme that the program is based upon and is represented by the following special characteristics.

Group Dynamics: The selection process will be based on bringing together a group of people with a wide range of experience in their academic and occupational areas, be it technological, planning management, administration, or law. Thus, the student group’s line-up will reflect the heterogeneous profiles, which are often found within a company’s typical departmental work group.

Project Work: For the duration of the programme two to three groups of students will team-up as virtual companies to develop a wind energy project from the green field to the selling of the wind farm. This project work provides a lot of practical experience, which reflects what the students learn in classes, and copies ‘real’ experience in communication with experts from a variety of disciplines.

Teaching Material: The reading material is divided into basic and speciality sections. The basic sections are obligatory for all the students. And, students must select half of the specialized sections to be examined upon, therefore allowing them to focus on their personal areas of expertise and interest.

Lecturers and Co-Lecturers: The seminars are lead by the authors of the teaching material who are leading experts from universities and industry. The main lecturer’s seminars are complemented by co-lecturers and guest speakers who give insight into their professional experience.

The administrators of the *Continuing Studies Programme in Wind Energy Technology*

and Management operate an active network of alumni for the students to stay in touch with each other, to assist them in the exchange of professional information, and to support further continuing education possibilities. Yearly alumni meetings take place in Oldenburg or Bremerhaven.

Summary

The *Continuing Studies Programme Wind Energy Technology and Management* is especially designed to support companies and professionals of the wind energy sector. After twelve years of successful operation it has consolidated its position as well-established programme of continuing academic education in the wind energy sector even if the numbers of applications and participants has been declining since the year 2013.

Link

www.windstudium.de

European Wind Energy Master (EWEM)

Carl von Ossietzky Universität Oldenburg
ForWind Head Office

Institute of Physics
Research Group: Wind Energy Systems
Research Group: Energy Meteorology
Research Group: Turbulence, Wind Energy and Stochastics

Martin Kühn, Joachim Peinke,
Detlev Heinemann, Moses Kärn

Partners:
Delft University of Technology (TU Delft),
Technical University of Denmark (DTU),
Norwegian University of Science and Technology (NTNU)

Introduction

ForWind is co-founder of the European Wind Energy Master (EWEM) which is supported by the European Commission as an Erasmus Mundus Master Course. A network of associated partners, composed of the main wind energy research institutions, industry and NGOs reinforces the consortium. During the five cohorts since 2012 EWEM has educated 169 students from 43 nationalities.

Project Description

The EWEM- European Wind Energy Master is an advanced two-year (120 ECTS) master course (MSc) with four specializations (see also Fig. 1):

- Wind Physics
- Rotor Design
- Electric Power Systems
- Offshore Engineering

The EWEM prepares graduates for a career in research, both in industry and in academia, and is closely linked to the research taking place at the four universities and their partners. ForWind / University of Oldenburg (UOL) is teaming-up with DTU in the Wind Physics track. Graduates receive a double degree in M.Sc. Engineering Physics (UOL) and M.Sc. Wind Energy Engineering (DTU). From the 169 students in the first five cohorts 23 students have graduated in the Wind Physics track.

	First year (60 ECTS)		Second year (60 ECTS)	
	1 st semester	2 nd semester	3 rd semester	4 th semester
Electrical Power Systems		TU Delft	NTNU	
Offshore Engineering	Introduction to Wind Energy	TU Delft	NTNU	M.Sc. Thesis Free mobility
Rotor Design	DTU	TU Delft	DTU	
Wind Physics		CARL VON OSSIETZKY universität OLDENBURG	DTU	

Figure 1: Structure of the European Wind Energy Master (EWEM). Abbreviations: Delft University of Technology (TU Delft), Technical University of Denmark (DTU), Norwegian University of Science and Technology (NTNU), ForWind Institute at the Carl von Ossietzky Universität Oldenburg (UOL).
(source: <http://ewem.tudelft.nl/about-ewem/programme>)

Link
www.windenergymaster.eu

Smart Blades Symposium in Oldenburg

Carl von Ossietzky Universität Oldenburg
ForWind Head Office
Institute of Physics
Research Group: Turbulence, Wind Energy
and Stochastics

Joachim Peinke

Co-organizers:
Oliver Paschereit (TU Berlin), Christian
Willberg (DLR)



The organizers of the symposium and invited guest speakers (from left): Flemming Rasmussen (DTU), Prof. Dr. Joachim Peinke (ForWind), Prof. Dr. Oliver Paschereit (TU Berlin), Dr.-Ing. Christian Willberg (DLR), Prof. Dr. Jan-Willem van Wingerden (TU Delft)

With the aim of discussing approaches, methods and results of the two ongoing research projects on intelligent rotor blades, researchers of the BMWi joint research project "Smart Blades - Development and Design of Intelligent Rotor Blades" and the DFG research project "Lastenkontrolle von Windturbinen unter realistischen turbulenten Anströmungen" ("Load Control of Wind Turbines under realistic turbulent flow") came together for a Symposium in Oldenburg in February 2015.

Approximately 60 scientists from ForWind, DLR, Fraunhofer IWES Nordwest, the RWTH Aachen University, TU Berlin, TU Darmstadt, the University of Oldenburg, and the University of Stuttgart met for two days at the Institute of Physics at the University of Oldenburg. They discussed recent research results, exchanged ideas with each other and with invited international speakers and visited the wind tunnel and laboratories on site. The Symposium was organized by Prof. Dr. Joachim Peinke (ForWind), Prof. Dr. Oliver Paschereit (TU Berlin), and Dr.-Ing. Christian Willberg (DLR).



Welcome address by Prof. Dr. Joachim Peinke Lab tour with active grid



Participants of the Smart Blades Symposium in Oldenburg

Job and Education Fair "zukunftsenergien nordwest" 2015

Carl von Ossietzky Universität Oldenburg
ForWind Head Office

Christoph Schwarzer

Partners:

Windenergieagentur WAB e.V.,
Oldenburger Energiecluster OLEC e.V.,
Wirtschaftsförderung der
Stadt Bremerhaven (BIS),
WFB Wirtschaftsförderung Bremen
GmbH,
Wirtschaftsförderung Stadt Oldenburg,
Hochschule Bremerhaven

Sponsored by:

Bremer Landesbank, Enercon GmbH



The job and education fair for renewable energies and energy efficiency, the "zukunftsenergien nordwest", opened its gates for the sixth time on the 20th and 21st March 2015 in Hall 4 of the Bremen Exhibition Centre. 62 exhibitors were presenting themselves on the job fair: companies, universities, institutes for further training and research institutes involved in renewable energies and energy efficiency. 2.500 visitors met attractive employers with open job opportunities and traineeships. The majority of the exhibitors came from the wind energy sector or are leaders in the field of energy efficiency. Visitors could talk to the personnel directly at the trade fair booth

and get informed about career opportunities in a personal conversation. The fields include electrical engineering/electronics, mechanical engineering, industrial engineering, economics, civil engineering and energy technology. Beside the exhibition, visitors could take part in workshops and company presentations. The forums offered valuable tips on starting a career, starting salaries or assessment centers. This program was complemented by excursions to well known companies and regional facilities as well as application trainings. Admission to the fair and the supporting program with excursions and lectures was free of charge.

The "zukunftsenergien nordwest" offered exhibitors a high profile public platform where companies and service providers meet together with an audience interested in their sector along with potential young applicants and those looking to enter from other fields of expertise.

The "zukunftsenergien nordwest" is supposed to take place once a year alternating in Oldenburg and Bremen. It started 2010 in Oldenburg. The program and all exhibitors with their details on personnel requirements can be found online at www.zukunftsenergien-nordwest.de.

zukunftsenergien
nordwest JOB- & BILDUNGSMESSE

Hannover Messe 2015

ForWind Head Office



Committee on Economic Affairs, Employment and Transport of the Lower Saxony Parliament

In April 2015 ForWind participated again in the Hannover Messe – the world's biggest industrial fair – at the joint stand of Lower Saxony, introducing ForWind and its services in research, consultancy, education, and events.

Amongst others, ForWind presented the active grid, which makes it possible to produce turbulent dynamic flows under controlled conditions in the laboratory. The heart of the large wind tunnel currently under construction in Oldenburg can realistically simulate all types of wind situations with its rhombic aluminum wings, from the mild breeze to strongly turbulent storms. This opens up new possibilities for the operation and further development of wind turbines.

Furthermore, ForWind showed a newly developed wind scanner. This is based on the remote sensing method Lidar (Light detection and ranging), which measures air flows with high temporal and spatial resolution. The new compact design of the

measuring device allows it to be mounted directly on the wind turbine. It actively supports the control of the turbines and helps to reduce the wind gust load.

Another exhibit from the field of flow measurement was the sphere anemometer. ForWind scientists improved and refined its technology continuously in the past years. It allows wind speed and direction to be measured simultaneously and at high frequency. Due to its particularly stable shape and the absence of moving parts, the device is ideally suited for offshore use.

Interested visitors of the fair could also inform themselves about the further training opportunities at ForWind: Two continuing study programs on onshore and offshore wind energy are aimed at specialists and managers in this field of industry. In its seminars, the ForWind Academy combines practice-related questions with current scientific findings.

As in previous years, ForWind took part in the Tec2You student campaign and answered the questions of several school groups.

Besides the various visitors from industry, research and the interested public, representatives of ForWind were pleased about discussions with the Minister for Science and Culture, Dr. Gabriele Heinen-Kljajić, the Minister for Economic Affairs, Employment and Transport, Olaf Lies, and the Minister for the Environment, Energy and Climate Protection, Stefan Wenzel.

For the first time, Maroš Šefčovič, Vice President for Energy Union of the new European Commission, visited the event to learn more about wind energy research and the turbulent wind tunnel under construction in Oldenburg. In addition, members of Lower Saxony's state parliament and the European Parliament informed themselves about current developments at ForWind.



Member of the European Parliament, Reinhard Bütikofer (Die Grünen/EFA) and Dr. Stephan Barth, Managing Director of ForWind"



Vice-President for Energy Union of the new European Commission, Maroš Šefčovič

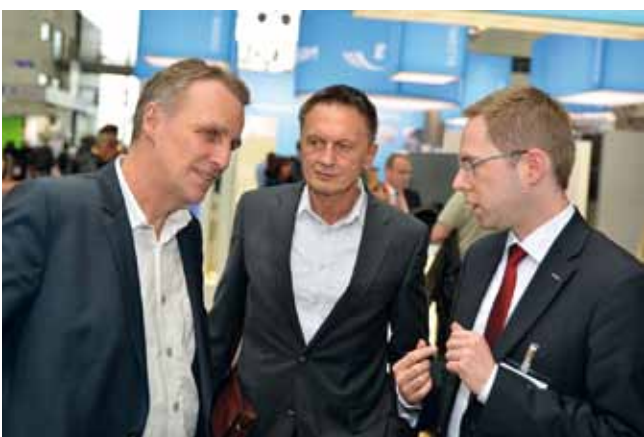

from left to right: Lower Saxony Minister for the Environment, Energy and Climate Protection, Stefan Wenzel; Michael Lindenthal, Head of Department 5 of the Ministry of the Environment (Energy, Climate Protection), and Dr. Stephan Barth, Managing Director of ForWind



Lower Saxony Minister for Science and Culture, Dr. Gabriele Heinen-Kljajić, and Dr. Stephan Barth, Managing Director of ForWind



Lower Saxony Minister for Economic Affairs, Employment and Transport, Olaf Lies



ForWind was once again a tour point for many school groups as part of the young talent initiative Tec2You.

Visit of the Vice-President for the Energy Union and Energy Minister

ForWind Head Office

The Vice-President of the European Commission for the Energy Union, Maroš Šefčovič, the Lower Saxony Minister for the Environment, Energy and Climate Protection, Stefan Wenzel, the Regional Ministers for Energy & Environment Nienke Homan (Province of Groningen) and Tjisse Stelpstra (Province of Drenthe),

and Dr. Werner Brinker, CEO of EWE AG visited ForWind at the University of Oldenburg together with a delegation of representatives from industry and government. The core of the visit was a tour through the research laboratory for turbulence and wind energy systems and the large turbulence wind tunnel currently under construction.

The speaker of the executive board of ForWind, Prof. Dr. Martin Kühn, explained the spectrum of ForWind's research activities and the planned investigations to the delegation. Šefčovič and Wenzel were impressed by the size and future experimental possibilities of the 20.5 million Euro project. Following the visit, Šefčovič announced via his Twitter account: "We need spread the word of Lower Saxony world class research on Sustainable Energy".



Figure 1: from left to right: Prof. Dr. Martin Kühn (ForWind), Maroš Šefčovič (Vice-President of the European Commission for the Energy Union), Dr. Detlev Heinemann (ForWind), Stefan Wenzel (Lower Saxony Minister for the Environment, Energy and Climate Protection), Prof. Dr. Joachim Peinke (ForWind), Nienke Homan (Minister for Energy & Environment Province of Groningen), Dr. Werner Brinker (CEO of EWE AG), Tjisse Stelpstra (Minister for Energy & Environment Province of Drenthe), and Dr. Stephan Barth (ForWind)



Cooperation with Taiwanese University – first Summer School realized

Carl von Ossietzky Universität Oldenburg
Institute of Physics
Research Group: Energy Meteorology
Research Group: Turbulence, Wind Energy
and Stochastics

Joachim Peinke, Detlev Heinemann,
Hendrik HeiBelmann, Michael Schmidt

Partner: Jan-Christoph Hinrichs, Aerodyn
Engineering GmbH

Funding: German Academic Exchange
Service (DAAD)

In close cooperation with the National Cheng Kung University (NCKU) in Tainan, Taiwan, ForWind has organized a Summer School. Funded by the German Academic Exchange Service (DAAD), the Summer School "Aerodynamics and Energy Meteorology for Renewable Energy Conversion: Aspects of the Physical, Statistical and Meteorological Understanding of Wind, Turbulence and Turbines", took place from 7th to 14th September 2015 at the NCKU in Tainan.

More than 70 students and 16 representatives of the Taiwanese industry participated in the 6-day course at the NCKU Department of Aeronautics and Aerodynamics.

Lectures and exercises given by ForWind researchers Prof. Dr. Joachim Peinke, Dr. Detlev Heinemann, Hendrik HeiBelmann and Michael Schmidt as well as Jan-Christoph Hinrichs from Aerodyn Engineering GmbH covered the basics of wind energy generation and added a focus on the regional typhoon risks and their mitigation by typhoon-resistant turbines.

Within the framework of the Summer School, the Department for Aeronautics and Astronautics (DAA) at NCKU and ForWind Oldenburg agreed to further extend their cooperation.



Prof. Dr. Ta-Hui Lin, Director of the Department for Aeronautics and Astronautics (DAA), handed over an award to Prof. Dr. Joachim Peinke for the successful cooperation at the Summer School.



In front (from left to right): Prof. Dr. T.S. Leu, Prof. Dr. J.J. Miao (both NCKU Tainan), Prof. Dr. Cheng-Dar Yue (National Chiayi University, Taiwan), Hendrik HeiBelmann, Dr. Detlev Heinemann, Prof. Dr. Joachim Peinke and Michael Schmidt (all ForWind). Prof. Dr. Cheng-Dar Yue made his PhD at the University of Oldenburg.

WindLab – New Research Building for Wind Energy Research

Carl von Ossietzky Universität Oldenburg
ForWind Head Office

Research Group: Wind Energy Systems
Research Group: Energy Meteorology
Research Group: Turbulence, Wind Energy
and Stochastics

Martin Kühn, Joachim Peinke,
Detlev Heinemann

In March 2015 the carcass of the new research laboratory for turbulence and wind energy systems (WindLab) was completed and the topping-out ceremony took place on the Wechloy campus of the University of Oldenburg. The heart of the 2,300 square meter new building is a turbulent wind tunnel, which enables scientists to investigate the interaction of turbulent flows with wind turbines and their components, and complete wind farms. The aim is a better understanding of turbulent flows and to obtain precise data on the operating behavior of wind turbines and large offshore wind farms. The new building was approved by the German Council of Science and Humanities in 2012 and classified as particularly worthy of promotion. Guests at the topping-out ceremony included Lower Saxony's Finance Minister Peter-Jürgen Schneider and Wilhelm Wickbold, Chief Construction Director of the State Construction Management Lüneburger Heide. Minister Schneider was impressed by the progress of the construction and expressed his thanks to all those involved in the construction so far.

After completion of the carcass in 2015, the entire building was completed at the end of 2016. It was officially inaugurated on January 26th, 2017, in the presence of Lower Saxony's Minister for Science and Culture, Gabriele Heinen-Kljajić. "The sustainable energy supply from renewable energies is a central challenge of our time," explained the Minister. "Renewable energies have



On the photo (from left): Energy meteorologist Dr. Detlev Heinemann, turbulence researcher Prof. Dr. Joachim Peinke; Chief Building Director Wilhelm Wickbold; interim University President Prof. Dr. Katharina Al-Shamery; Finance Minister Peter-Jürgen Schneider; ForWind Managing Director Dr. Stephan Barth; architect Veit Schäfer

been successfully researched at the University of Oldenburg for many years. With the WindLab, excellent conditions have been created to further strengthen research in the field of wind energy".

The WindLab offers space for more than 130 scientists, a wind tunnel with a 30-meter-long measuring section and wind speeds of up to 150 kilometers per hour. "With the WindLab and the associated turbulence wind tunnel, we have a unique research infrastructure for wind energy," emphasized University President Prof. Dr. Dr. Hans Michael Piper at the opening ceremony. Both the technical equipment and the synergies resulting from the cooperation of the interdisciplinary team of experts are outstanding.

Wind energy scientists from the Universities of Oldenburg and Hanover, the Jade University, the Fraunhofer Institute for Wind Energy and Energy System Technol-

ogy (Bremerhaven) and the Max Planck Institute for Dynamics and Self-Organization (Göttingen) will benefit from the new facilities. Scientists from Oldenburg, led by wind energy expert Prof. Dr. Martin Kühn, turbulence researcher Prof. Dr. Joachim Peinke and energy meteorologist Dr. Detlev Heinemann, were responsible for the contents of the application for the new research building.

In comparison to wind tunnels, such as those used in aviation, realistic wind fields can be simulated in the turbulent Oldenburg wind tunnel as they occur in nature. The investigations should help to increase the efficiency of wind farms and avoid technical and financial risks. "Our great vision is to achieve a new quality in wind energy research through the combination of measurements in the open field, numerical simulations and the new experimental possibilities in the turbulent wind tunnel," explained Peinke.

The WindLab was designed by the architect's office HammesKrauseArchitekten.

The total costs of around 20 million euros are shared equally between the national government and the state of Lower Saxony.



Front of the new WindLab

The new WindLab from a bird's eye view in summer 2016



Symbolic key handover in the wind tunnel:

Science Minister Gabriele Heinen-Kljajić (3rd from right) with University President Prof. Dr. Dr. Hans Michael Piper (2nd from right) and Chief Construction Director of the State Construction Management Lüneburger Heide, Michael Brassel.

Also in the picture (from left): ForWind Managing Director Dr. Stephan Barth; wind energy expert Prof. Dr. Martin Kühn, turbulence researcher Prof. Dr. Joachim Peinke; State Secretary of the Lower Saxony Ministry for the Environment, Energy and Climate Protection, Almut Kottwitz; Energy Programme Director at the German Aerospace Center (DLR), Bernhard Milow; Oldenburg Mayor Germaid Eilers-Dörfler



Equipment parameters

- rated voltage up to 690 V
- permanent magnet synchronous machine with respective full converter
[$P_N = 1.2 \text{ MW}$, $n_N = 375 \text{ min}^{-1}$ (0 - 750 min^{-1})]
- doubly-fed induction machine with respective wind converter
[$P_N = 2.08 \text{ MW}$, $n_N = 1780 \text{ min}^{-1}$]
- converter-based grid modelling
[$S_N = 4.4 \text{ MVA}$; unbalance, freely adjustable frequency and harmonics]
- maximum component weight 20 t
- base area of span 10 m x 4.3 m

Tests

- steady-state and transient operating conditions (Ψ , P_v , M , U , I , ECD, ...)
- temperature rise and loss distribution
- diagnostic methods

on electrical machines:

- flux distribution, end-winding fields
- current displacement, circulating

currents

- Additional losses through harmonics
- Winding defects and their diagnosis

With the test bench it is possible

- Test your motor or generator prototype with different types of converters for fault diagnostics, performance validation, and analytical modelling and design method development
- Carry out investigations on our generation (PMSM and DFIG) or your components using our sensor types, such as torque, position, speed, voltage, current, flux, vibration, temperature, etc.
- Carry out investigations on both conventional and innovative converter and generator concepts including control and filter design methods. This includes investigations into dynamics and system stability, stationary and transient thermal loading, various methods of grid control and the behaviour of grid faults, such as voltage dips, symmetrical and asymmet-

rical short circuits.

- Carry out investigations on the converter-generator interactions and their influence on other system components, such as bearings and gearboxes.

Summary

GeCoLab offers an optimal solution for research on the electrical drive train of wind turbines and Hydrogenerators. A quick change of components is made possible by a tensioning field and on-site 20t crane. The machine foundation is decoupled from the building by means of pneumatic spring elements. In addition, a readily accessible terminal box is installed to replace the inverter with a test object. Researchers on the mentioned topics result in an improved validation of analytical modelling, diagnostic procedures and advanced simulation model for electrical and mechanical components for a better design of generator and converter.



Figure 2: Installed test bench

Supported by:



on the basis of a decision
by the German Bundestag

References

- [1] <https://www.tth.uni-hannover.de/159.html>

Minister President of Lower Saxony Stephan Weil visits ForWind

ForWind Head Office

"Lower Saxony is No. 1 of the Wind Energy Lands and is also at the forefront of wind energy research. I am delighted that we have one of the top addresses for international research in this field here in Oldenburg," said Minister President Stephan Weil during his visit in June 2017 at

ForWind at the University of Oldenburg. On his summer trip, Weil took a look at the new research infrastructure of the Laboratory for Turbulence and Wind Energy Systems (WindLab), with its unique turbulence wind tunnel. The system makes it possible to reproduce and analyze the interaction between realistic turbulent wind flows on the one hand and wind turbines and wind farms on the other in the lab. The scientists have developed powerful

turbulence generators and scaled research wind turbines for this purpose, which Weil was impressed by. "Wind energy is one of the supporting elements of the future energy supply," said the Minister President of Lower Saxony. "The University of Oldenburg has been expanding research in this field for many years and is making an active contribution to the success of the energy transition."



Minister President of Lower Saxony Stephan Weil (3rd from right) visits ForWind. Besides (from left to right) ForWind managing director Dr. Stephan Barth, wind energy expert Prof. Dr. Martin Kühn, Oldenburg's Mayor Jürgen Krogmann, University President Prof. Dr. Hans Michael Piper and turbulence researcher Prof. Dr. Joachim Peinke.



Minister President Stephan Weil also inspected Oldenburg's new turbulence wind tunnel and the associated components.



Didn't fear the self-test: Minister President Weil, together with the University President Prof. Dr. Hans Michael Piper and the wind energy expert Prof. Dr. Martin Kühn, stepped into the wind.

ForWind Symposia

Carl von Ossietzky Universität Oldenburg
ForWind Head Office
Institute of Physics

Research Group: Wind Energy Systems
Research Group: Energy Meteorology
Research Group: Turbulence, Wind Energy
and Stochastics

Martin Kühn, Joachim Peinke,
Detlev Heinemann, Stephan Barth

Symposium "Results from Wind Physics"

Wind turbines in wind farms and wind farm clusters influence each other through interaction with the atmospheric boundary layer. This has far-reaching consequences, in particular for the achievable energy yields and the turbine loads. Both the large offshore wind farms with nominal capacities of several 100 MW and the onshore wind farms have optimization potential in planning, monitoring and control. In order to give interested persons from industry and project partners an overview of current results and an insight in wind energy research projects, ForWind organized the Symposium "Results from Wind Physics" ("Ergebnisse aus der Windphysik") on June 14th, 2017, in Oldenburg.

In cooperation with the partners involved, results from the following recently completed collaborative projects were presented:

- GW Wakes – Analysis of shadowing effects and wake turbulence characteristics of large Offshore-wind farms by comparison of *alpha ventus* and *Riffgat*
- OWEA Loads – Probabilistic load description, monitoring and reduction of loads of future offshore wind energy converters
- CompactWind – Increase of the Overall Energy Yield per Area at Sites Due to the Utilization of Advanced Single Turbine and Wind Farm Control Strategies





Participants of the ForWind Symposium "Results from Wind Physics"



The current state of research was presented and discussed on a cross-project basis. The topics ranged from the interaction of wind parks with the atmospheric boundary

layer to plant loads, plant monitoring and control strategies for individual plants and wind parks.

Symposium "Perspectives on Turbulence and Wind Energy Research"

 		
Symposium »Perspectives on Turbulence and Wind Energy Research« Institute of Physics Carl von Ossietzky University Oldenburg, K�pkersweg 70, WindLab W33-0-003, Oldenburg, Germany 1-December 2017 <i>(Draft 29th Nov. 2017)</i>		
10:00	Martin Holthaus Vice-President for Research & Transfer, University Oldenburg	Welcome address
10:15	Joachim Peinke & Martin K�hn ForWind - Oldenburg	Turbulence and wind energy research – Scientific challenges
10:30	Marta Waclawczyk Institute of Geophysics, University of Warsaw	Estimation of Taylor's and Kolmogorov's microscale in atmospheric turbulence
11:00	Juan-Pedro Mellado Max Planck Institute for Meteorology, Hamburg	The challenge of small-scale turbulence in planetary boundary layers
11:30	J�rge Schneemann ForWind - Oldenburg	Turbulence analysis from Doppler lidar measurements
11:45	Martin D�renk�mper Fraunhofer IWES, Oldenburg	On the impact of realistic offshore exploration scenarios on wind conditions in the German Bight
12:00	Lunch	
13:00	Bastian Dose ForWind - Oldenburg	Simulation of fluid-structure-interaction at large wind turbine rotor blades
13:15	Christina He�seling LaVision GmbH, G�ttingen	3D flow field velocity measurements by Digital Holographic PTV
13:30	Dominik Traphan ForWind - Oldenburg	Universal characteristics of laminar separation bubbles on airfoils
13:45	Cornelia Kalender Wind Engineering and Fluid Mechanics, University Bochum	Synergistic collaboration of experimental and numerical modelling of the turbulent atmospheric boundary layer flow for wind engineering applications
14:15	Coffee break	
14:45	Michael Wilczek MP Group Theory of Turbulent Flows, G�ttingen	Turbulent fluctuations - from the small scales to atmospheric boundary layers
15:15	Richard Stevens Physics of Fluids group, University of Twente	Large eddy simulations and modeling of the interaction between large wind farms and the turbulent atmospheric boundary layer
15:45	Discussion on future perspectives	
16:15	Farewell	Laboratory tour incl. turbulent wind tunnel at the WindLab (optional)

As part of the further development of the research concept of the Carl von Ossietzky University Oldenburg in the field of wind physics, ForWind organized a symposium with young scientists in the WindLab on December 1st, 2017. The focus was on the perspectives in turbulence and wind energy research.

The program covered almost the full range of topics from turbulence research to wind energy applications, from physical and meteorological to engineering questions as well as theoretical, numerical and experimental methods. Five longer lectures by young scientists were combined with four shorter in-house lectures. In addition, we were able to invite Prof. Marc Avila, Director of ZARM Bremen, to discuss the perspectives of further cooperation with the University of Bremen.

References

- [1] <https://symposium2017.forwind.de>
 [2] <https://symposium2017-2.forwind.de>

Documentation

Publication Lists

Peer Reviewed Articles

- Albiker, J.; Achmus, M.; Frick, D.; Flindt, F.:
1g Model Tests on the Displacement Accumulation of Large-Diameter Piles Under Cyclic Lateral Loading
Geotechnical Testing Journal 40 (2): March 2017
- Andersen, S. J.; Witha, B.; Breton, S.-P.; Sørensen, J. N.; Mikkelsen, R. F.; Ivanell, S.:
Quantifying variability of Large Eddy Simulations of very large wind farms
J. Phys.: Conf. Ser., 625, 012027, doi: 10.1088/1742-6596/625/1/012027 (2015)
- Anvari, M.; Werther, B.; Lohmann, G.; Wächter, M.; Peinke, J.; Beck, H.-P.:
Suppressing power output fluctuations of photovoltaic power plants
Solar Energy, vol. 157, pp. 735–743, 2017
- Bastine, D.; Witha, B.; Wächter, M.; Peinke, J.:
Towards a Simplified Dynamic Wake Model using POD Analysis
Energies, 8, pp. 895-920, doi:10.3390/en8020895 (2015)
- Beck, H., Schmidt, M., Kühn, M.:
Dynamic data filtering of long-range Lidar wind speed measurements
Remote Sens., 9(6), p. 561 (2017)
- Brandt, S.; Broggi, M.; Häfele, J.; Gebhardt, C. G.; Rolfes, R.; Beer, M.:
Meta-models for fatigue damage estimation of offshore wind turbines jacket substructures
Procedia Engineering, Band 199, Seite(n): 1158-1163. DOI: 10.1016/j.proeng.2017.09.292 (2017)
- Bromm, M., Vollmer, L., Kühn, M.:
Numerical investigation of wind turbine wake development in directionally sheared inflow
Wind Energy, 20:381–395 (2017), published online 21 July 2016
- Chattopadhyay, K.; Kies, A.; Lorenz, E.; von Bremen, L.; Heinemann, D.:
The impact of different PV module configurations on storage and additional balancing needs for a fully renewable European power system
Renewable Energy, 113, pp. 176-189, doi:10.1016/j.renene.2017.05.069 (2017)
- Cordes, U.; Kampers, G.; Meißner, T.; Tropea, C.; Peinke, J.; Hölling, M.:
Note on the limitations of the Theodorsen and Sears functions
Journal of Fluid Mechanics, vol. 811, 2017
- Dörenkämper, M.; Optis, M.; Monahan, A.; Steinfeld, G.:
On the offshore advection of boundary-layer structures and the influence on offshore wind conditions
Boundary-Layer Meteorol., 155, pp. 459-482, doi:10.1007/s10546-015-0008-x (2015)
- Dörenkämper, M., Witha, B., Steinfeld, G., Heinemann, D., Kühn, M.:
The impact of stable atmospheric boundary layers on wind-turbine wakes within offshore wind farms
Journal of Wind Engineering and Industrial Aerodynamics, 144, pp. 146-153 (2015)
- Gauterin, E., Kammerer, P., Kühn, M., Schulte, H.:
Effective wind speed estimation: Comparison between Kalman Filter and Takagi–Sugeno observer techniques
ISA Transaction 62, pp. 60-72 (2016)
- Gebhardt, C. G.; Benedikt, H.; Hente, C.; Rolfes, R.:
Nonlinear dynamics of slender structures: a new object-oriented framework
Computational Mechanics, pp. 1-34 (2018)
- Häfele, J.; Hübler, C.; Gebhardt, C. G.; Rolfes, R.:
An improved two-step soil-structure interaction modeling method for dynamical analyses of offshore wind turbines
Applied Ocean Research, 55, pp. 141-150 (2016)
- Hartwig, S.; Marx, S.:
Torsionstragverhalten extern vorgespannter Kressegmente mit trockenen Fugen
Beton- und Stahlbetonbau 112, pp. 740-746 (2017)
- Hartwig, S.; Marx, S.:
Torsionstragverhalten extern vorgespannter Kressegmente mit trockenen Fugen
Beton- und Stahlbetonbau 112, pp. 740-746 (2017)
- Haselsteiner, A. F.; Ohlendorf, J.-H.; Wosniok, W.; Thoben, K.-D.:
Deriving environmental contours from highest density regions
In: Coastal Engineering; Volume 123; pp. 42-51; May 2017
- Hellsten, A.; Luukkonen, S. M.; Steinfeld, G.; Kanani-Sühring, F.; Markkanen, T.; Järvi, L.; Lento, J.; Vesala, T.; Raasch, S.:
Footprint Evaluation for Flux and Concentration Measurements for an Urban-Like Canopy with Coupled Lagrangian Stochastic and Large-Eddy Simulation Models
Boundary-Layer Meteorol., 157(2), pp. 191-217. https://doi.org/10.1007/s10546-015-0062-4 (2015)

- Herrmann, R.; Rabe, J.; Bolle, G.; Marx, S.:
Konzepte für Datenqualität und Datenabfrage bei Entwurf und Umsetzung von Monitoringsystemen
Bauingenieur 92, pp. 537-545 (2017)
- Herrmann, R.; Rabe, J.; Bolle, G.; Marx, S.:
Konzepte für Datenqualität und Datenablage bei Entwurf und Umsetzung von Monitoringsystemen
Bauingenieur 92, pp. 537-545 (2017)
- Hübler, C.; Gebhardt, C. G.; Rolfes, R.:
Development of a comprehensive database of scattering environmental conditions and simulation constraints for offshore wind turbines
Wind Energy Science, 2, pp. 491-505 (2017)
- Hübler, C.; Gebhardt, C. G.; Rolfes, R.:
Hierarchical four-step global sensitivity analysis of offshore wind turbines based on aerodynamic time-domain simulations
Renewable Energy, 111, pp. 878-891 (2017)
- Hümme, J.; von der Haar, C.; Lohaus, L.; Marx, S.:
Fatigue behaviour of a normal-strength concrete – number of cycles to failure and strain development
Structural Concrete 17, pp. 637-645 (2016)
- Junk, C.; Späth, S.; von Bremen, L.; Delle Monache, L.:
Comparison and Combination of Regional and Global Ensemble Prediction Systems for Probabilistic Predictions of Hub-Height Wind Speed
Weather and Forecasting, 30(5), pp. 1234-1253, doi:10.1175/WAF-D-15-0021.1 (2015)
- Junk, C.; Delle Monache, L.; Alessandrini, S.; Cervone, G.; von Bremen, L.:
Predictor-weighting strategies for probabilistic wind power forecasting with an analog ensemble
Meteorol. Z., 24(4), pp. 361-379, doi:10.1127/metz/2015/0659 (2015)
- Kies, A.; Schyska, B.U.; von Bremen, L.:
Curtailement in a Highly Renewable Power System and Its Effect on Capacity Factors
Energies, 9(7), 510, doi:10.3390/en9070510 (2016)
- Kies, A.; Schyska, B.U.; von Bremen, L.:
The Effect of Hydro Power on the Optimal Distribution of Wind and Solar Generation Facilities in a Simplified Highly Renewable European Power System
Energy Procedia, 97, pp. 149-155 (2016)
- Kies, A.; Schyska, B.U.; von Bremen, L.:
The optimal share of wave power in a highly renewable power system on the Iberian Peninsula
Energy reports, 2, pp. 221-228, doi:10.1016/j.egy.2016.09.002 (2016)
- Kies, A.; Schyska, B.U.; von Bremen, L.:
The Demand Side Management Potential to Balance a Highly Renewable European Power System
Energies, 9(11), 955, doi:10.3390/en9110955 (2016)
- Knigge, C.; Raasch, S.:
Improvement and development of one- and two-dimensional discrete gust models using a large-eddy simulation model
Journal of Wind Engineering and Industrial Aerodynamics, 153, pp. 46-59 (2016)
- Lind, P. G.; Vera-Tudela, L.; Wächter, M.; Kühn, M.; Peinke, J.:
Normal behaviour models for wind turbine vibrations: An alternative approach
arXiv:1710.08676
- Lind, P., Vera-Tudela, L., Wächter, M., Kühn, M., Peinke, J.:
Normal behaviour models for wind turbine vibrations: Comparison of neural networks and a stochastic approach
Energies 10; 12, p. 1944 (2017)
- Lohaus, L.:
Untersuchungen zum Ermüdungsverhalten eines höherfesten Normalbetons
Beton- und Stahlbetonbau 110, pp. 699-709 (2015)
- Luhur, M. R., Peinke, J., Wächter, M., Kühn, M.:
Stochastic Model for Aerodynamic Force Dynamics on Wind Turbine Blades in Unsteady Wind Inflow
Journal of Computational and Nonlinear Dynamics, Volume 10, Issue 4 (2015)
- Mehrens, A. R.; von Bremen, L.:
On the correlation of spatial wind speed and solar irradiance variability above the North Sea
Advances in Science and Research, 13, pp. 57-61, doi:10.5194/asr-13-57-2016 (2016)
- Mehrens, A. R.; von Bremen, L.:
Comparison of methods for the identification of mesoscale wind speed fluctuations
Meteorol. Z., 26(3), pp. 333-342, doi:10.1127/metz/2017/0826 (2017)
- Mittelmeier, N., Allin, J., Blodau, T., Trabucchi, D., Steinfeld, G., Rott, A., Kühn, M.:
An analysis of offshore wind farm SCADA measurements to identify key parameters influencing the magnitude of wake effects
Wind Energ. Sci., 2, pp. 477-490 (2017)
- Mittelmeier, N., Blodau, T. and Kühn, M.:
Monitoring offshore wind farm power performance with SCADA data and advanced wake model
Wind Energy Science 2, pp. 175-187 (2017)
- Oelker, S.; Lewandowski, M.; Alla, A. A.; Ohlendorf, J. H.; Haselsteiner, A. F.:
Logistikszenerarien für die Errichtung von Offshore-Windparks – Herausforderungen der Wirtschaftlichkeitsbetrachtung neuer Logistikkonzepte
In: Industrie 4.0 Management; Volume 3; No. 1; pp. 24-28; ISSN 2364-9208 (2017)
- Oelker, S.; Lewandowski, M.; Freitag, M.:
Konzept einer preagierenden Instandhaltungsstrategie – Effiziente Instandhaltung und automatisierte Logistik in der Betriebsphase von Offshore-Windenergieanlagen
In: Industrie Management; Zeitschrift für industrielle Geschäftsprozesse; Jahrgang 31; Nr. 5; S. 40-44; ISSN 1434-1980 (2015)

- Pauscher, L., Vasiljevic, N., Callies, D., Lea, G., Mann, J., Klaas, T., Hieronimus, J., Gottschall, J., Schwesig, A., Kühn, M., Courtney, M.:
An Inter-Comparison Study of Multi- and DBS Lidar Measurements in Complex Terrain
Remote Sens., 8, 782 (2016)
- Perrone, F., Kühn M.:
Offshore Wind Turbine Tower Fore-Aft Fatigue Load Reduction by Coupling Control and Vibrational Analysis
Journal of Ocean and Wind Energy, Vol. 2, No. 3, pp. 168–175 (2015)
- Reinke, N.; Homeyer, T.; Hölling, M.; Peinke, J.:
Flow modulation by an active grid
arXiv:1703.00721, 2017
- Rockel, S.; Peinke, J.; Hölling, M.; Bayoán Cal, R.:
Dynamic wake development of a floating wind turbine in free pitch motion subjected to turbulent inflow generated with an active grid
Renewable Energy, vol. 112, pp. 1–16, 2017
- Santos-Alamillos, F. J.; Pozo-Vázquez, D.; Ruiz-Arias, J.A.; von Bremen, L.; Tovar-Pescador, J.:
Combining wind farms with concentrating solar plants to provide stable renewable power
Renewable Energy, 76, pp. 539-550, doi:10.1016/j.renene.2014.11.055 (2015)
- Schendel, A.; Hildebrandt, A.; Goseberg, N.; Schlurmann, T.:
Processes and evolution of scour around a monopile by tidal currents
Coastal Engineering, 139, pp. 65-84 (2018)
- Schmietendorf, K.; Peinke, J.; Kamps, O.:
The impact of turbulent renewable energy production on power grid stability and quality
The European Physical Journal B, vol. 90, no. 11, p. 222, 2017
- Schmoor, K.; Achmus, M.:
Optimum Geometry of Monopiles with Respect to the Geotechnical Design
Journal of Ocean and Wind Energy Vol. 2, No. 1, February 2015, pp. 54-60
- Scholz, T.; Raischel, F.; Lopes, V. V.; Lehle, B.; Wächter, M.; Peinke, J.; Lind, P. G.:
Parameter-free resolution of the superposition of stochastic signals
Physics Letters A, vol. 381, no. 4, pp. 194–206, 2017
- Schottler, J.; Hölling, A.; Peinke, J.; Hölling, M.:
Brief communication: On the influence of vertical wind shear on the combined power output of two model wind turbines in yaw
Wind Energy Science, vol. 2, no. 2, pp. 439–442, 2017
- Schottler, J.; Reinke, N.; Hölling, A.; Whale, J.; Peinke, J.; Hölling, M.:
On the impact of non-Gaussian wind statistics on wind turbines-an experimental approach
Wind Energy Science, vol. 2, no. 1, p. 1, 2017
- Schramm, M.; Rahimi, H.; Stoevesandt, B.; Tangager, K.:
The Influence of Eroded Blades on Wind Turbine Performance Using Numerical Simulations
Energies, vol. 10, no. 9, p. 1420, 2017
- Schwack, F.; Stammler, M.; Poll, G.; Reuter, A.:
Comparison of Life Calculations for Oscillating Bearings Considering Individual Pitch Control in Wind Turbines
J. Phys.: Conf. Ser. 753 pp.112013 (2016)
- Shimada, S.; Ohsawa, T.; Kogaki, T.; Steinfeld, G.; Heinemann, D.:
Effects of Sea Surface Temperature Accuracy on Offshore Wind Resource Assessment Using a Mesoscale Model
Wind Energy, 18(10), pp. 1839-1854, doi:10.1002/we.1796 (2015)
- Späth, S.; von Bremen, L.; Junk, C.; Heinemann, D.:
Time-consistent calibration of short-term regional wind power ensemble forecasts
Meteorol. Z., 24(4), pp. 381-392, doi:10.1127/metz/2015/0664 (2015)
- Tabrizi, A. B.; Whale, J.; Lyons, T.; Urmee, T.; Peinke, J.:
Modelling the structural loading of a small wind turbine at a highly turbulent site via modifications to the Kaimal turbulence spectra
Renewable Energy, vol. 105, pp. 288–300, 2017
- Thieken, K.; Achmus, M.; Lemke, K.:
A new static p-y approach for piles with arbitrary dimensions in sand geotechnik 38 (4), pp. 267-288 (2015)
- Thieken, K.; Achmus, M.; Lemke, K.; Terceiros, M.:
Evaluation of p-y approaches for large diameter monopiles in sand
International Journal of Offshore and Polar Engineering (IJOPE), Vol. 25, No. 2, June 2015, pp. 134-144
- Trabucchi, D.; Vollmer, L.; Kühn, M.:
Shear layer approximation of Navier-Stokes steady equations for non-axisymmetric wind turbine wakes: description, verification and first application
Journal of Physics: Conference Series, 753, 032030, doi: 10.1088/1742-6596/753/3/032030 (2016)
- Trabucchi, D., Vollmer, L., Kühn, M.:
3-D shear-layer model for the simulation of multiple wind turbine wakes: description and first assessment
Wind Energy Science. 2, pp. 569-586. (2017)
- Traphan, D.; Wester, T. T. B.; Gülker, G.; Peinke, J.; Lind, P. G.:
Directed percolation in aerodynamics: resolving laminar separation bubble on airfoils
DOI: 10.1103/PhysRevX.8.021015
arXiv:1707.06832
- Trujillo, J.J., Seifert, J.K., Würth, I., Schlipf, D., Kühn, M.:
Full-field assessment of wind turbine near-wake deviation in relation to yaw misalignment
Wind Energ. Sci., 1, pp. 41-53 (2016)

- Tsiapoki, S.; Häckell, M.W.; Griebmann, T.; Rolfes, R.:
Damage and ice detection on wind turbine rotor blades using a structural health monitoring framework
DOI: 10.1177/1475921717732730. (2017)
- van Dooren, M., Trabucchi, D., Kühn, M.:
A Methodology for the Reconstruction of 2D Horizontal Wind Fields of Wind Turbine Wakes Based on Dual-Doppler Lidar Measurements
Remote Sens. 8, 809 (2016)
- van Dooren, M. F., Campagnolo, F., Sjöholm, M., Angelou, N., Mikkelsen, T., Kühn, M.:
Demonstration and uncertainty analysis of synchronised scanning lidar measurements of 2-D velocity fields in a boundary-layer wind tunnel
Wind Energ. Sci., 2, pp. 329-341 (2017)
- Vera-Tudela, L., Kühn, M.:
Analysing wind turbine fatigue load prediction: The impact of wind farm flow conditions
Renewable Energy Journal, 107, pp. 352–360 (2017)
- Vollmer, L.; van Dooren, M.; Trabucchi, D.; Schneemann, J.; Steinfeld, G.; Witha, B.; Trujillo, J.; Kühn, M.:
First comparison of LES of an offshore wind turbine wake with dual-Doppler lidar measurements in a German offshore wind farm
J. Phys.: Conf. Ser., 625, 012001, doi: 10.1088/1742-6596/625/1/012001 (2015)
- Vollmer, L., Steinfeld, G., Heinemann, D., Kühn, M.:
Estimating the wake deflection downstream of a wind turbine in different atmospheric stabilities: An LES study
Wind Energ. Sci., 1, pp. 129–141 (2016)
- Vollmer, L., Steinfeld, G., Heinemann, D., Kühn, M.:
The wake deflection downstream of a wind turbine in different atmospheric stabilities: An LES study
Wind Energ. Sci., 1, 129-141 (2016)
- Vollmer, L.; Lee, J. C.-Y.; Steinfeld, G.; Lundquist, J. K.:
A wind turbine wake in changing atmospheric conditions: LES and lidar measurements
J. Phys.: Conf. Ser., 854, 012050, doi: 10.1088/1742-6596/854/1/012050 (2017)
- Vollmer, L., Steinfeld, G., and Kühn, M.:
Transient LES of an offshore wind turbine
Wind Energ. Sci., 2, pp. 603-614 (2017)
- von der Haar, C.; Hümme, J.; Marx, S.; Lohaus, L.:
Untersuchungen zum Ermüdungsverhalten eines höherfesten Normalbetons
Beton- und Stahlbetonbau 110, pp. 699-709 (2015)
- von der Haar, C.; Marx, S.:
Design Aspects of Concrete Towers for Wind Turbines
Journal of the South African Institution of Civil Engineering 57, pp. 30-37 (2015)
- von der Haar, C.; Marx, S.; Krompholz, R.:
Ultraschalluntersuchungen an statisch beanspruchten Betonproben
Beton- und Stahlbetonbau 110, pp. 759-766, (2015)
- von der Haar, C.; Marx, S.:
Untersuchungen zur Steifigkeit und Ultraschallgeschwindigkeit dynamisch beanspruchter Betonproben
Beton- und Stahlbetonbau 111, pp. 141-148, (2016)
- von der Haar, C.; Marx, S.:
Development of stiffness and ultrasonic pulse velocity of fatigue loaded concrete
Structural Concrete 17, pp. 630-636, (2016)
- von der Haar, C.; Hümme, J.; Marx, S.; Knigge, C.; Raasch, S.:
Improvement and development of one- and two-dimensional discrete gust models using a large-eddy simulation model
Journal of Wind Engineering and Industrial Aerodynamics, 153, pp. 46-59 (2016)
- von der Haar, C.; Marx, S.:
Ein additives Dehnungsmodell für ermüdungsbeanspruchten Beton
Beton- und Stahlbetonbau 112, pp. 31-40 (2017)
- Vorspel, L.; Schramm, M.; Stoevesandt, B.; Brunold, L.; Bünner, M.:
A benchmark study on the efficiency of unconstrained optimization algorithms in 2D-aerodynamic shape design
Cogent Engineering, vol. 4, no. 1, p. 1354509, 2017
- Wahl, B.; Feudel, U.; Hlinka, J.; Wächter, M.; Peinke, J.; Freund, J. A.:
Conditional Granger causality of diffusion processes
The European Physical Journal B, vol. 90, no. 10, p. 197, 2017

Articles, Conference Proceedings, Conference Contributions

Abdel-Rahman, K.; Achmus, M.:

Numerical Modelling of Pile Groups Composed of two open-ended Steel Piles

GeoMEast – Sustainable Civil Infrastructures: Innovative Infrastructure Geotechnology, July 15-19, 2017, Sharm El-Sheikh, Egypt

Achmus, M.; Lemke, K.; Abdel-Rahman, K.; Kuo, Y.-S.:

Numerical Approach for the Derivation of Interaction Diagrams for Piles under Cyclic Axial Loading

Proceedings of the Twenty-fifth (2015) International Ocean and Polar Engineering Conference Kona, Big Island, Hawaii, USA, June 21-26, 2015

Achmus, M.; Thieken, K.; Lemke, K.:

Evaluation of a new p-y approach for piles in sand with arbitrary dimensions

3rd International Symposium on Frontiers in Geotechnics (ISFOG), Oslo, Norway, June 10-12, 2015

Achmus, M.:

Design of Foundation Elements for Offshore Wind Energy Converters

Keynote lecture, 15. Int. Conference on Structural and Geotechnical Engineering (ICSGE), Cairo/ Egypt, December 20-22, 2015

Achmus, M.; Gütz, P.; Gerlach, T.:

Numerical modeling of the behavior of bucket foundations in sand under transient tensile loading

6th Int. Conference on Structural Engineering, Mechanics and Computation (SEMC), Cape Town/ South Africa, September 5-7, 2016

Achmus, M.; Terceros, M.; Thieken, K.:

Evaluation of p-y approaches for large diameter monopiles in soft clay

26th Int. Ocean and Polar Engineering Conference (ISOPE), Rhodes/Greece, June 26-July 2, 2016

Achmus, M.; Abdel-Rahman, K.; Schäfer, D.; Kuo, Y.-S.; Chung, C.-Y.; Tseng, Y.-H.:

Interaction Diagrams for Driven Steel Piles under Cyclic Axial Loading

27th Int. Ocean and Polar Engineering Conference (ISOPE), San Francisco/USA, June 25-30, 2017

Achmus, M.; Abdel-Rahman, K.; Schaefer, D.; Kuo, Y.-S.; Chung, C.-Y.; Tseng, Y.-H.:

Capacity Degradation Method for Driven Steel Piles under Cyclic Axial Loading.

In Proceedings of the 27th International Ocean and Polas Engineering Conference (pp. 362-368). San Francisco, Kalifornien, USA (2017).

Achmus, M.; Terceros, M.; Thieken, K.:

Assessment of p-y Approaches for Piles in Normally and Over-Consolidated Soft Clay

27th Int. Ocean and Polar Engineering Conference (ISOPE), San Francisco/USA, June 25-30, 2017

Achmus, M.; Thieken, K.; tom Würden, F.; Terceros, M.:

Assessment of pile length criteria for monopiles

8th Int. Offshore Site Investigation and Geotechnics Conference, Society of Underwater Technology (SUT), September 12-14, 2017, London/UK

Achmus, M.:

Bearing behavior and design of monopiles used as foundations for offshore wind energy converters

Keynote lecture at the 3rd International Soil-Structure Interaction Symposium, October 18-19, 2017, Izmir, Turkey

Albiker, J.; Achmus, M.; Thieken, K.:

Numerical Simulation of Cyclic Horizontally Loaded Piles Under Special Loading Conditions

12th German Wind Energy Conference DEWEK 2015, May 19-20, 2015, Bremen

Andersen, S. J.; Witha, B.; Breton, S.-P.; Sørensen, J. N.; Mikkelsen, R. F.; Ivanell, S.:

Quantifying Variability In LES Simulations of Very Large Wind Farms

Wake Conference 2015, Visby, Sweden, June, 09-11, 2015 (oral) (2015)

Bahrami, O.; Tsiapoki, S.; Kane, M.B.; Lynch, J.P.; Rolfes, R.:

Extraction of Environmental and Operational Conditions of Wind Turbine from Tower Response Data for Improved Structural Health Monitoring

the 11th International Workshop on Structural Health Monitoring (IWSHM 2017), Stanford University, California, USA. (2017)

Bartschat, A.; Morisse, M.; Mertens, A.; Wenske, J.:

Analysis of Dynamic Interactions between Different Drivetrain Components with a Detailed Wind Turbine Model, The Science of Making Torque from Wind (TORQUE 2016)

München, October 5-7, 2016

Basheer, N.; Abdel-Rahman, K.; Albiker, J.; Chakraborty, T.; Achmus, M.:

Numerical Modelling of Offshore Rock Socketed Monopile Foundations

15th Int. Conference on Structural and Geotechnical Engineering (ICSGE), Cairo/ Egypt, December 20-22, 2015

Bastine, D., Wächter, M., Peinke, J., Trabbucchi, D., Kühn M.:

Characterizing Wake Turbulence with Staring Lidar Measurements

Wake Conference, Visby, Sweden. Journal of Physics: Conference Series 625, 012006 (2015)

Baust, S.:

Global and local FE-modelling of rotor bearings in Ansys and validation of results

1st Young Tribological Researcher Symposium, 2017, Hannover

Beck, H., Trujillo, J.J., Kühn, M.:

Analysis of wake sweeping effects based on load and long-range lidar measurements

DEWEK 2015, Bremen, Germany, Proceedings of the German Wind Energy Conference DEWEK (2015)

Benedikt, H.; Gebhardt, C. G.; Hente, C.; Rolfes, R.:

Sparsity pattern extraction for assembly of KKT-like matrices in multibody dynamics

Proceedings in Applied Mathematics and Mechanics, 89th GAMM Annual Meeting (2018)

- Berger, F., Kühn, M.:
Investigating the aerodynamic implications of slender wind turbine blade design
DEWEK 2015, Bremen, Germany
Proceedings of the German Wind Energy Conference DEWEK (2015)
- Boersma, S., Vali, M., Kühn, M., van Wingerden, J.-W.:
Quasi Linear Parameter Varying modeling for wind farm control using the 2D Navier-Stokes equations
ACC 2016; Boston, MA, USA 2016.
pp. 4409 – 4414 (2016)
- Böske, L.N.; Raasch, S.:
Large-eddy simulation as a tool for onshore wind turbine site assessment
4th International Education Forum on Environment and Energy Science (ACEEES), Maui, Hawaii, USA
6-10 Dec. 2015
- Böske, L.N.:
Large-eddy simulation as a tool for site assessment in complex environment
Wind Energy Science Conference, Copenhagen, Danmark
June 26-29, 2017
- Brandt, S.; Broggi, M.; Häfele, J.; Hübler, C.; Gebhardt, C. G.; Beer, M.; Rolfes, R.:
Meta-models for fatigue damage estimation of offshore wind turbines jacket substructures.
Procedia Engineering (199), pp. 1158-1163 (2017)
- Bromm, M., Kühn, M.:
Numerical investigation of wake development in a stable atmospheric boundary layer
DEWEK 2015, Bremen, Germany,
Proceedings of the German Wind Energy Conference DEWEK (2015)
- Buhr, R.; Aposporidis, A.; Munk, J.; Steinfeld, G.; Heinemann, D.:
RANS simulations of flows above forest canopies of different topologies
Wind Energy Science Conference 2017, Lyngby, Denmark, June 26-29, 2017 (oral) (2017)
- Bustamante, A., Vera-Tudela, L., Kühn, M.:
Evaluation of wind farm effects on fatigue loads of an individual wind turbine
at the EnBW Baltic 1 offshore wind farm Wake Conference, Visby, Sweden. Journal of Physics: Conference Series 625, 012020 (2015)
- Dörenkämper, M.; Junk, C.; von Bremen, L.; Steinfeld, G.; Heinemann, D.; Kühn, M.:
Advances in monitoring, simulation and short-term forecasting at the offshore wind farm "EnBW Baltic 1"
DEWEK 2015, Bremen, Germany, 19 - 20 May 2015 (oral) (2015)
- Dubois, J.; Schaumann, P.; Thieken, K.; Achmus, M.:
Zum Ansatz der lastabhängigen Gründungssteifigkeit in gesamt-dynamischen Simulationen von Offshore Windenergieanlagen
Seminar „Stahl im Wasserbau 2015“, September 30-October 10, 2015, Braunschweig
- Dubois, J.; Thieken, K.; Terceros, M.; Schaumann, P.; Achmus, M.:
Advanced Incorporation of Soil-Structure Interaction into Integrated Load Simulation
26th Int. Ocean and Polar Engineering Conference (ISOPE), Rhodes/Greece, June 26-July 2, 2016
- Ehrmann A.; Penner N.; Gebhardt C. G.; Rolfes R.:
Offshore Support Structures with Suction Buckets: Parameter Fitting of a Simplified Foundation Model
in: Proceedings of the 26th International Ocean and Polar Engineering Conference, ISOPE 2016, Rhodes (Greece)
- Ehrmann A.; Gebhardt C. G.; Rolfes R.:
A Hierarchical Clustering Approach for Jacket Substructures for Offshore Wind Farms according to Location-Dependent Environmental Conditions
1st Wind Energy Science Conference, WESC 2017, Lyngby (Denmark)
- Franke, J.; Richrath, M.; Thoben, K.-D.:
Forscher automatisieren Rotorblattfertigung
In: MM Maschinen Markt, CW Composites World; 35/2016; pp. 30-35; August 2016
- Fuchs, A.; Reinke, N.; Guelker, G.; Peinke, J.:
Experimental investigations of flow fields generated by fractal and regular grids
Progress in Turbulence VI, Proc. iTi Conference in Turbulence, Bertinoro, Springer, 2017
- Gerendt, C.; Jansen, E.; Rolfes, R.:
A Fatigue Damage Model for Fiber Metal Laminates Including Fiber/Matrix Degradation
6th ECCOMAS Thematic Conference on the Mechanical Response of Composites (ECCOMAS COMPOSITES), Eindhoven, Netherlands (2017)
- Gütz, P.; Achmus, M.; Thieken, K.:
Model testing of suction bucket foundations under tensile loading in non-cohesive soil
8th Int. Offshore Site Investigation and Geotechnics Conference, Society of Underwater Technology (SUT), September 12th-14th 2017, London/UK
- Gütz, P.; Achmus, M.; Schröder, C.:
Comparison of methods for the determination of the tensile bearing behavior of suction bucket foundations in sand
3rd International Soil-Structure Interaction Symposium, October 18th-19th 2017, Izmir, Turkey
- Häfele, J.; Rolfes, R.:
Approaching the ideal design of jacket substructures for offshore wind turbines with a Particle Swarm Optimization algorithm
In Proceedings of the 26th International Ocean and Polar Engineering Conference pp. 156-163. Rhodos, Griechenland (2016)

Häfele, J.; Hübler, C.; Gebhardt, C. G.; Rolfes, R.:
An improved two-step soil-structure interaction modeling method for dynamical analyses of offshore wind turbines
 Applied Ocean Research (55), pp. 141-150 (2016)

Häfele, J.; Hübler, C.; Gebhardt, C. G.; Rolfes, R.:
Efficient Fatigue Limit State Design Load Sets for Jacket Substructures Considering Probability Distributions of Environmental States
 In Proceedings of the 27th International Ocean and Polar Engineering Conference pp. 167-173. San Francisco, Kalifornien, USA (2017)

Häfele, J.; Hübler, C.; Gebhardt, C. G.; Rolfes, R.:
Reconsidering fatigue limit state load sets for jacket substructures utilizing probability distributions of environmental states
 Proceeding of the Twenty-seventh International Ocean and Polar Engineering Conference San Francisco, CA, USA, June 25-30, 2017; ISBN: 978-1-880653-97-5 (2017)

Hahmann, A.; Montornés, A.; Casso, P.; Volker, P.; Witha, B.:
Bigger is better. Is it really?
 Wind Energy Science Conference 2017, Lyngby, Denmark, 26 - 29 June 2017 (oral) (2017)

Hansen, M.; Schmidt, B.; Kelma, S.; Schmoor, K.; Goretzka, J.:
Probabilistic Assessment of the Foundation of Offshore Wind Turbines
 Proceedings of the IABSE Conference - Elegance in Structures, Nara, Japan, May 13th-15th 2015

Hübler, C.; Häfele, J.; Ehrmann, A.; Rolfes, R.:
Effective consideration of soil characteristics in time domain simulations of bottom fixed offshore wind turbines
 In Proceedings of the 26th International Ocean and Polar Engineering Conference (pp. 127-134). Rhodos, Griechenland (2016)

Hübler, C.; Müller, F.; Gebhardt, C. G.; Rolfes, R.:
Global Sensitivity Analysis of Offshore Wind Turbine Substructures
 15th International Probabilistic Workshop (2017)

Ivanell, S.; Arnqvist, J.; Witha, B.:
Ryningsnäs Benchmark – A forested site modelled with different microscale model approaches
 Wind Energy Science Conference 2017, Lyngby, Denmark, June 26 - 29, 2017 (oral) (2017)

Jacobsen, S.; Lehner, S.; Hieronimus, J., Schneemann, J., Kühn, M.:
Joint offshore wind field monitoring with spaceborne SAR and platform-based LiDAR measurements
 ISRSE36, Berlin, Germany (2015)

Kies, A.; Schyska, B.U.; von Bremen, L.:
How Much Can Demand Side Management Contribute to Balance a Fully Renewable European Power System?
 EMS 2016, Trieste, Italy, September, 12 – 16, 2016 (oral) (2016)

Kies, A. et al.:
Backup, Storage and Transmission Estimates of a Supra-European Electricity Grid with High Shares of Renewables
 14th Wind Integration Workshop, Brussels, Belgium, October 20 – 22, 2015 (oral) (2015)

Kies, A. et al.:
Transmission, Storage and Backup Estimates for a Global Electricity Grid with High Shares of Renewables
 11th Eawe PhD Seminar on Wind Energy in Europe, Stuttgart, Germany, September 23 - 25, 2015 (oral) (2015)

Kies, A. et al.:
Effects of Scandinavian hydro power on storage needs in a fully renewable European power system for various transmission capacity scenarios
 EGU General Assembly 2015, Vienna, Austria, April 12 – 17, 2015 (oral) (2015)

Kies, A. et al.:
Trade-off between reduced storage and extended inter-country transmission needs in an European energy system dominated by renewables
 12th German Wind Energy Conference (DEWEK 2015), Bremen, Germany, May 19 – 20, 2015 (oral) (2015)

Kies, A. et al.:
The temporal development of storage needs in the European energy transition
 DPG Spring Meeting, Berlin, Germany, March 15 – 20, 2015 (oral) (2015)

Krüger, S.; Witha, B.; Heinemann, D.:
Investigation of the Development of Internal Boundary Layers by Means of Large-Eddy Simulation
 EMS 2017, Dublin, Ireland, September 4 – 8, 2017 (oral) (2017)

Krutova, M.; Kies, A.; Schyska, B.U.; von Bremen, L.:
The Smoothing Effect in an Afro-Eurasian Renewable Power Grid
 EMS 2016, Trieste, Italy, September 12 – 16, 2016 (oral) (2016)

Kuhnle, B., Kühn, K.:
Strukturelle Dämpfer – Ein alter Hut oder Innovation für große Windenergieanlagen?
 6. VDI - Fachtagung Schwingungen in Windenergieanlagen 2015, Bremen, Germany (2015)

Kuhnle, B., Kühn, M.:
Unfavourable trends of rotor speed and systems dynamics for very large offshore wind turbines – Analysis of the 10MW INNWIND.EU reference turbine
 EWEA Offshore 2015, Copenhagen, Denmark (2015)

Lieske, M.; Schendel, A.; Schulz, N.; Stahlmann, A.; Hildebrandt, A.; Schlurmann, T.:
Untersuchungen zur Hydro- und Morphodynamik bei Wellen-Strömungs-Interaktion anhand physikalischer Modellversuche (3D-Wellen-Strömungsbecken)
 In Tagungsband zum Kongress der Hafentechnischen Gesellschaft e.V. (pp. 163-172). Bremen: Eigenverlag HTG (2015)

- Lohaus, L.; Tomann, C.; Weicken, H.:
Combined formwork and textile reinforcement system for a mineral corrosion protection layer for offshore application
In 11th International Symposium of Ferrocement and 3rd ICTRC International Conference on Textile Reinforced Concrete, RILEM Proceedings PRO98 (pp. 287-294). Aachen (2015)
- Mehrens, A. R.:
Korrelation der Windgeschwindigkeit über der Nord- und Ostsee
4. Fachtagung Energiemetereologie 2016, Bremerhaven, Germany, April 20 – 22 (oral) (2016)
- Mehrens, A. R.; von Bremen, L.; Heinemann, D.:
Characterization of Mesoscale Wind Fluctuations in space and time
12th German Wind Energy Conference (DEWEK 2015), Bremen, Germany, May 19 – 20, 2015 (oral) (2015)
- Mehrens, A. R.; von Bremen, L.; Heinemann, D.:
Mesoscale wind fluctuations and their correlation with solar variability
15th EMS Annual Meeting, Sofia, Bulgaria, September 07 – 11, 2015 (oral) (2015)
- Mittelmeier, N., Blodau, T., Kühn, K.:
Offshore Wake Model Validation – Methodology for Linking Model Results and Operational Data
DEWEK 2015, Bremen, Germany, Proceedings of the German Wind Energy Conference DEWEK (2015)
- Mittelmeier, N., Blodau, T., Steinfeld, G., Rott, A., Kühn, M.:
An analysis of offshore wind farm SCADA measurements to identify key parameters influencing the magnitude of wake effects
Journal of Physics: Conference Series. 2016; 753(3):032052 (2016)
- Monner, H. P.; Huxdorf, O.; Pohl, M.; Riemenschneider, J.; Homeyer, T.; Hölling, M.:
Smart structures for wind energy turbines
25th AIAA/AHS Adaptive Structures Conference, AIAA SciTech Forum, Grapevine, Texas, January 9-13, 2017
- Morisse, M.; Bartschat, A.; Wenske, J.; Mertens, A.:
Dependency of the Lifetime Estimation of Power Modules in Fully Rated Wind Turbine Converters on the Modelling Depth of the Overall System
18th European Conference on Power Electronics and Applications (EPE'16-ECCE Europe), Karlsruhe, Germany, September 5.-9. 2016
- Morisse, M.; Bartschat, A.; Wenske, J.; Mertens, A.:
Converter Lifetime Assessment for Doubly-Fed Induction Generators Considering Derating Control Strategies at Low Rotor Frequencies
TORQUE 2016, München, Germany, Oktober 5.-7, 2016
- Neunaber, I.; Schottler, J.; Peinke, J.; Hölling, M.:
Comparison of the development of a wind turbine wake under different inflow conditions
in Progress in Turbulence VII, Springer Proceedings in Physics 196, pp. 177-182, 2017
- Ohlendorf, J.-H.; Franke, J.; Schmohl, T.; Thoben, K.-D.:
Automation strategies in rotor blade production: preforming vs. direct textile layup
In: JEC Composite Magazin; Volume 99; pp. 35-37; ISSN 1639-965X; 2015
- Ohlendorf, J.-H.; Franke, J.; Rolbier, M.; Schmohl, T.; Thoben, K.-D.; Ischtschuk, L.:
Preforming in großer Dimension – innovativer Ansatz in der Rotorblattfertigung
In: Konstruktion; Zeitschrift für Produktentwicklung und Ingenieur-Werkstoffe; Volume 68; No. 3; pp. 75-79; ISSN 0720-5953; 2016
- Ohsawa, T.; Orita, T.; Kozai, K.; Shimada, S.; Steinfeld, G.; Heinemann, D.:
Accuracy estimation of hub-height wind speeds estimated from scatterometer and mesoscale model
EWEA Offshore 2015, Copenhagen, Denmark, 10-12 Mar 2015 (poster) (2015)
- Penner N.; Rolfes R.:
Soil Stiffness Evaluation and Bearing Behavior of a Suction Bucket Jacket Prototype
Presentation at the International Modal Analysis Conference, IMAC 2017, Garden Grove (USA)
- Raasch, S.:
Scalability of atmospheric turbulence simulations on next generation hybrid computer architectures – Challenges and perspectives
Heraeus-Seminar "Science Application for Exascale Computing - Exploring New Avenues towards Scalability and Fault-Tolerance", Bad Honnef, Germany September 9, 2015
- Raasch, S.:
Simulation of atmospheric turbulence
10th Spring School on Transition and Turbulence (EPTT 2016), São José dos Campos, Brazil September 22, 2016
- Raasch, S.:
New trends in high resolution large-eddy simulation of the atmospheric boundary layer: From fundamental to applied research
Center for Mechanics, Uncertainty and Simulation in ENGINEERING – MUSEN, TU Braunschweig, Germany June 22, 2017
- Raasch, S.:
High resolution atmospheric turbulence simulations for applied problems
SIAM conference on mathematical and computational issues in the geosciences, Erlangen, Germany September 13, 2017
- Richrath, M.; Franke, J.; Ohlendorf, J.-H.; Thoben, K.-D.:
Effektor für die automatisierte Direktablage von Textilien in der Rotorblattfertigung
In: Lightweight Design; Volume 10; No. 5; pp. 48-53; ISSN 1865-4819 (Print) / 2192-8738 (Online); 2017
- Richrath, M.; Franke, J.; Ohlendorf, J.-H.; Thoben, K.-D.:
Effector for automated direct textile placement in rotor blade production
In: Lightweight Design worldwide; Volume 10; No. 5; pp. 42-47; 2017

Rott, A., Boersma S., van Wingerden, J.-W., Kühn, M.:

Dynamic Flow Model for Real-Time Application in Wind Farm Control
Journal of Physics: Conference Series, Volume 854 (2017)

Schendel, A.; Hildebrandt, A.; Schlurmann, T.:

Experimental study on the progression of scour around a monopile in unidirectional and tidal currents
In Proceedings of the 6th International Conference on the Application of Physical Modelling in Coastal and Port Engineering and Science (Coastlab16). Ottawa, Kanada (2016)

Schmidt, B.; Hansen, M.; Marx, S.:
Directional Dependence of Extreme Load Parameters for Offshore Wind Turbines

Proceedings of the 25th International Offshore and Polar Engineering Conference (ISOPE), Kona, Big Island, Hawaii, USA, 2015

Schmidt, B.; Marx, S.; Hansen, M.:
Measurement Based Investigation of Directional Dependence of Extreme Load Parameters for Offshore Wind Turbines

Proceedings of the 12th German Wind Energy Conference (DEWEK), Bremen, Germany, May 19th-20th 2015

Schmidt, M., Trujillo, J.J., Kühn, M.:
Orientation correction of wind direction measurements by means of staring lidar
J. Phys.: Conf. Ser. 749 012005 (2016)

Schmoor, K.; Achmus, M.; Foglia, A.; Wefer, M.:
Reliability of design approaches for axially loaded offshore piles and its consequences with respect to the North Sea

15th International Conference of the International Association for Computer Methods and Advances in Geomechanics (15th IACMAG), October 19-23, 2017, Wuhan, China

Schneemann, J., Bastine, D., v. Dooren, M., Schmidt, J., Steinfeld, G., Trabucchi, D., Trujillo, J.J., Vollmer, L., Kühn, M.:
"GW WAKES": measurements of wake effects in »alpha ventus« with synchronised long-range LiDAR wind-scanners

DEWEK, Bremen, Germany, Proceedings of the German Wind Energy Conference DEWEK (2015)

Schneemann, J., Hieronimus, J., Jacobsen, S., Lehner, S., Kühn, M.:
Offshore wind farm flow measured by complementary remote sensing techniques: radar satellite TerraSAR-X and lidar windscanners

Wake Conference, Visby, Sweden. Journal of Physics: Conference Series 625, 012015 (2015)

Schottler, J.; Mühle, F.; Bartl, J.; Peinke, J.; Adaramola, M. S.; Sætran, L.; Hölling, M.:
Comparative study on the wake deflection behind yawed wind turbine models

Journal of Physics: Conference Series, Volume 854, conference 1, 2017

Schröder, K.; Gebhardt, C.G.; Rolfes, R.:
Damage Localization at Wind Turbine Support Structures Using Sequential Quadratic Programming for Model Updating

Proceedings of the 8th European Workshop on Structural Health Monitoring (2016)

Schwack, F.; Stammler, M.; Flory, H.; Poll, G.:
Free Contact Angles in Pitch Bearings and their Impact on Contact and Stress Conditions

WindEurope Conference, Hamburg (2016)

Schyska, B.U.; Couto, A.; von Bremen, L.; Estqueiro, A.:
Weather Dependent Upscaling Algorithms for European Wind Power
EMS 2016, Trieste, Italy, September 12 – 16, 2016 (oral) (2016)

Schyska, B.U.; Kies, A.; von Bremen, L.:
Deriving an optimal Grid Design for integrating Offshore Wind Energy successfully

Integration of Sustainable Energy Conference, Nuremberg, Germany, July 11 – 12, 2016 (oral) (2016)

Schyska, B.U.; von Bremen, L.:
Optimizing Power System Integration based on the Energy Ratio
EAWC PhD Seminar, Stuttgart, Germany, September 23 – 25, 2015 (oral) (2015)

Schyska, B.U.; Kies, A.; von Bremen, L.:
Curtailed Affected Capacity Factors – The Role of Storages
International Renewable Energy and Storages Conference, Düsseldorf, Germany, March 15 – 17, 2016 (Poster) (2016)

Schyska, B. et al.:
Facing Europe: Revised wind power upscaling algorithms
DPG Spring Meeting, Berlin, Germany, March 15 – 20, 2015 (2015)

Schyska, B.; von Bremen, L.:
Conviviality in Energy: Designing a Renewable Energy System in a Degrowth Society

11th biennial conference of the European Society for Ecological Economics, Leeds, UK, June 30 – July 03, 2015 (oral) (2015)

Seifert, J., Vera-Tudela, L., Kühn, M.:
Data analysis via clustering exemplified by wind turbine wake identification
12th EAWC PhD Seminar on Wind Energy in Europe, May 25-27, 2016, Lyngby Denmark

Seifert, J., Vera-Tudela, L., Kühn, M.:
Training requirements of a neural network used for fatigue load estimation of offshore wind turbines
EERA DeepWind – 14th Deep Sea Offshore Wind R&D Conference, Trondheim, Norway. Energy Procedia 137; 315-322 (2017)

- Shimada, S.; Ohsawa, T.; Takeyama, Y.; Kogaki, T.; Steinfeld, G.; Heinemann, D.: **Comparison of wind speeds simulated with WRF using seven planetary boundary layer schemes at two offshore met masts in the North Sea** EWEA Offshore 2015, Copenhagen, Denmark, March 10 – 12, 2015 (poster) (2015)
- Shirzadeh, R. Kühn, M.: **Application of two passive strategies on the load mitigation of large offshore wind turbines** Journal of Physics: Conference Series 749; 012011 (2016)
- Shirzadeh, R., Kühn, M.: **Support structure load mitigation of a large offshore wind turbine using a semi-active magnetorheological damper** EERA DeepWind – 14th Deep Sea Offshore Wind R&D Conference, Trondheim, Norway. Energy Procedia (2017)
- Shrestha, B., Kühn, M.: **Adaptation of Controller Concepts for Support Structure Load Mitigation of Offshore Wind Turbines** 13th Deep Sea Offshore Wind R&D Conference, EERA DeepWind' 2016, Trondheim, Norway, Energy Procedia (2016)
- Shrestha, B., Kühn, M.: **Tailoring the Employment of Offshore Wind Turbine Support Structure Load Mitigation Controllers** Journal of Physics: Conference Series; 753(5):052032 (2016)
- Späth, S.; von Bremen, L.; Junk, C.: **Time-consistent calibration of regional wind power ensemble forecasts based on COSMO-DE EPS** COSMO/CLM/ART User Seminar 2015, Offenbach, Germany, March 06 - 08, 2014 (oral) (2015)
- Späth, S. et al.: **Ways to generate probabilistic wind power forecasts from ensemble weather forecasts** Wind Integration Workshop 2015, Offenbach, Germany, March 06 - 08, 2015 (oral) (2015)
- Stammler, M.; Wenske, J.: **Integration von Schadensmechanismus-analyse und Blattlagertests in den Entwicklungsprozess von WKA** VDI-Fachtagung Gleit- und Wälzlagerungen, 5/7/2015, Schweinfurt
- Stammler, M.; Reuter, A.: **Blade bearings: damage mechanisms and test strategies** Conference for Wind Power Drives, 3/4/2015 - 3/4/2015, Aachen
- Steinfeld, G.; Schmidt, M.; Heinemann, D.: **WASA – Wind- und Stabilitätsatlas für die südliche Nordsee** 4. Fachtagung Energiemeteorologie, Bremerhaven, Germany, April 20 - 22, 2016 (oral) (2016)
- Stümpel, M.; Marx, S.: **An Innovative Hybrid Substructure Made of High-Strength Concrete and Ductile Cast Iron for Offshore Wind Turbines** Proceedings of the 13th German Wind Energy Conference (DEWEK), Bremen, Germany, Oct. 17-18, 2017
- Stümpel, M.; Marx, S.; Schaumann, P. Seidl, G. Göhlmann, J.: **An Innovative Hybrid Substructure for Offshore Wind Turbines** Proceedings of the 27th International Offshore and Polar Engineering Conference (ISOPE), San Francisco, USA, June 25-30, 2017
- Terceros, M.; Achmus, M.; Thieken, K.: **Evaluation of p-y approaches for piles in soft clay** 8th Int. Offshore Site Investigation and Geotechnics Conference, Society of Underwater Technology (SUT), September 12-14, 2017, London/UK
- Thieken, K.; Achmus, M.; Lemke, K.: **Evaluation of a new p-y approach for piles in sand with arbitrary dimensions** In Proceedings of the 3rd International Symposium in Frontiers in Offshore Geotechnics (pp. 741-746). Oslo, Norwegen (2015)
- Thieken, K.: **Entwicklung neuer p-y-Ansätze für Pfähle beliebiger Abmessungen** In Baugrundtagung – Beiträge zur Spezialsitzung – Forum für junge Geotechnik-Ingenieure. Berlin (2016).
- Thieken, K.; Achmus, M.; Lemke, K.: **Bewertung statischer p-y-Ansätze für horizontal belastete Pfähle beliebiger Durchmesser in nichtbindigem Boden** Pfahlsymposium 2015, Braunschweig, February 19-20, 2015
- Thieken, K.; Achmus, M.; Terceros, M.; Dubois, J.; Gerlach, T.: **Describing Six-Degree-of-Freedom Response of Foundations Supporting OWEC Jacket Structures** 26th Int. Ocean and Polar Engineering Conference (ISOPE), Rhodes/Greece, pp.745-753, June 26-July 2, 2016
- Tomann, C.; Schack, T.; & Lohaus, L.: **Real Offshore Exposure Tests of a Mineral Corrosion Protection System** In Proceedings of the 27th International Offshore and Polar Engineering Conference. San Francisco, Kalifornien, USA (2017)
- Trabucchi, D., Steinfeld, G., Bastine, D., Trujillo, J.J., Schneemann, Kühn, M.: **Study of wake meandering by means of fixed point lidar measurements: Spectral analysis of line-of-sight wind component** Wake Conference, Visby, Sweden. Journal of Physics: Conference Series 625, 012016 (2015)
- Trabucchi, D., Vollmer, D., Kühn, M.: **Shear layer approximation of Navier-Stokes steady equations for non-axisymmetric wind turbine wakes: Description, verification and first application** Journal of Physics: Conference Series; 753(3):032030 (2016)
- Trabucchi, D., Trujillo, J. J., Ritter, K., Steiner, J., Kühn, M.: **Nacelle Based Lidar Measurements for the Characterisation of the Wake of an Offshore Wind Turbine under Different Atmospheric Conditions** EERA DeepWind – 14th Deep Sea Offshore Wind R&D Conference, Trondheim, Norway, Energy Procedia 137; pp. 77-88 (2017)

- Trujillo, J. J., Beck, H., Müller, K., Cheng, P. W., Kühn, M.:
A test case of meandering wake simulation with the Extended-Disk Particle model at alpha ventus
 EERA DeepWind – 14th Deep Sea Off-shore Wind R&D Conference, Trondheim, Norway. Energy Procedia (2017)
- Tsiapoki, S.; Häckell, M.W.; Rolfes, R.:
Monitoring of a 35 m Wind Turbine Rotor Blade During a Fatigue Test by a Modular SHM-Scheme
 The 10th International Workshop on Structural Health Monitoring (IWSHM 2015), Stanford University, California, USA. DOI: 10.12783/SHM2015/347 (2015)
- Tsiapoki, S.; Krause, T.; Häckell, M.W.; Ostermann, J.; Rolfes, R.:
Combining a vibration-based SHM-scheme and an airborne sound approach for damage detection on wind turbine rotor blades
 In the 8th European Workshop on Structural Health Monitoring (EWSHM 2016), Bilbao, Spain. (2016)
- Tsiapoki, S.; Lynch, J.P.; Häckell, M.W.; Rolfes, R.:
Improvement of the damage detection performance of a SHM framework using AdaBoost: Validation on an operating wind turbine
 11th International Workshop on Structural Health Monitoring (IWSHM 2017), Stanford University, California, USA. (2017)
- Unger, R.; Gerendt, C.; Daum, B.; Jansen, E.; Rolfes, R.; Ueing, C.; Englisch, N.; Sayer, F.; Exner, W.; Mahrholz, T.; Lorsch, P.; Wierach, P.:
Hybrid Laminates and Nanoparticle Reinforced Materials for Improved Rotor Blade Structures
 Advances in Rotor Blades for Wind Turbines, Bremen, April 5-7 2017, Bremen, Germany
- Unger, R.; Daum, B.; Braun, U.; Rolfes, R.:
Experimentally calibrated modeling technique for the cross linking mechanism of epoxy resin and its influence on mechanical properties,
 20th International Conference on Composite Structures (ICCS), Paris, France (2017)
- Unguran, R., Kühn, M.:
Combined individual pitch and trailing edge flap control for structural load alleviation of wind turbines
 ACC 2016; Boston, MA, USA; pp. 2307 – 2313 (2016)
- Vali, M., Wingerden, J.-W. van, Boersma, S., Petrovic, V., Kühn, M.:
A predictive control framework for optimal energy extraction of wind farms
 Journal of Physics: Conference Series 753; 052013 (2016)
- Vali, M., Wingerden, J.-W. van, Kühn, M.:
Optimal Multivariable Individual Pitch Control for Load Reduction of Large Wind Turbines
 ACC 2016; Boston, MA, USA; pp. 3163 – 3169 (2016)
- Vali, M., Petrovic, V., Boersma, S., Wingerden, J.-W., Kühn, M.:
Adjoint-based model predictive control of wind farms: Beyond the quasi steady-state power maximization
 IFAC PapersOnLine 50-1; 4510-4515 (2017)
- Valldecabres, L., Friedrichs, W., von Bremen, L., Kühn, M.:
Analysis of wind field fluctuations on wind farm power output
 12th EAWC PhD Seminar on Wind Energy in Europe, 25-27 May 2016, Lyngby Denmark
- Valldecabres, L., Friedrichs, W., von Bremen, L., Kühn, M.:
Spatial-temporal analysis of coherent offshore wind field structures measured by scanning Doppler-lidar
 Journal of Physics: Conference Series; 753(7):072028. (2016)
- van Dooren, M., Kühn, M., Petrovic, V., Bromm, M., Botasso, C. L., Camagnolo, F., Sjöholm, M., Angelou, N., Mikkelsen, T., Croce, A., Zasso, A.:
Demonstration of synchronised scanning lidar measurements of 2D velocity fields in a boundary-layer wind tunnel
 Journal of Physics: Conference Series; 753(7):072032. (2016)
- van Dooren, M., Trabucchi, D., Beck, H., Schneemann, J., Friedrichs, W., Kühn, M.:
Assessment of the global wind and the local wake direction at alpha ventus using long range scanning LiDAR
 EWEA Offshore 2015, PO.ID 183 Copenhagen, Denmark (2015)
- Vera-Tudela, L., Kühn, M.:
Evaluation of a wind turbine fatigue load monitoring system based on standard SCADA signals in different wind farm flow conditions
 DEWEK 2015, Bremen, Germany, Proceedings of the German Wind Energy Conference DEWEK (2015)
- Vollmer, L., van Dooren, M., Trabucchi, D., Schneemann, J., Steinfeld, G., Witha, B., Trujillo, J., Kühn, M.:
First comparison of LES of an offshore wind turbine wake with dual-Doppler lidar measurement in a German offshore wind farm
 Wake Conference, Visby, Sweden. Journal of Physics: Conference Series 625, 012001 (2015)
- Vollmer, L.; van Dooren, M.; Trabucchi, D.; Steinfeld, G.; Kühn, M.:
Comparison of dual-Doppler lidar measurements and Large Eddy Simulations of an offshore wind turbine wake
 RAVE Offshore Wind R&D 2015, Bremerhaven, Germany, October 13 - 15, 2015 (oral) (2015)
- von Bremen, L. et al.:
Advances in monitoring, simulation and short-term forecasting at the offshore wind farm "EnBW Baltic 1"
 12th German Wind Energy Conference (DEWEK 2015), Bremen, Germany, May 19 - 20, 2015 (oral) (2015)
- von Bremen, L.; Junk, C.; Späth, S.; Heinemann, D.:
Statistical methods for the development of skillful probabilistic wind power forecasts
 3rd International Conference Energy & Meteorology, Boulder, Colorado, USA, June 22 - 26, 2015 (oral) (2015)

von Bremen, L.; Kies, A.; Schyska, B.; Heinemann, D.:

Analysis of 100% Renewable Power Systems: Deployment Strategies and efficient Feed-in Monitoring

3rd International Conference Energy & Meteorology, Boulder, Colorado, USA, June 22 -26, 2015 (oral) (2015)

von der Haar, C.; Marx, S.:

Strain Development of plain High Strength Concrete under Fatigue Loading

Proceedings of the 4th International Symposium on Ultra-High Performance Concrete and High Performance Construction Materials (HiPerMat), Kassel, Germany, March 9-11, 2016

von der Haar, C.; Wedel, F.; Marx, S.:

Numerical and Experimental Investigations of the Warming of Fatigue-Loaded Concrete

Proceedings of the fib Symposium 2016, Cape Town, South Africa, November 21-23, 2016

Wagner, D.; Witha, B.; Wurps, H.;

Flügge, M.; Reuder, J.:

Evolution and properties of Low Level Jet events over the southern North Sea

Wind Energy Science Conference 2017, Lyngby, Denmark, June 26 - 29, 2017 (oral) (2017)

Wagner, D.; Steinfeld, G.; Witha, B.;

Wurps, H.; Krüger, S.; Reuder, J.:

Frequency and evolution of Low Level Jet events over the southern North Sea analysed from WRF simulations and LiDAR measurements

EMS 2017, Dublin, Ireland, September 04 - 08, 2017 (oral) (2017)

Wagner, D.; Steinfeld, G.; Witha, B.;

Flügge, M.; Reuder, J.:

Low Level Jets over FINO1 - Observations and Modelling

IRP Wind Conference 2017, Amsterdam, Netherlands, September 25 - 26, 2017 (oral) (2017)

Weber, S.; Schlüter, M.; Borowski, D.; Mertens, A.:

Simple analog detection of turn-off delay time for IGBT junction temperature estimation

2016 IEEE Energy Conversion Congress and Exposition (ECCE), Milwaukee, WI, USA, September 18.-22. 2016

Wernitz, S.; Pache, D.; Griebmann, T.; Rolfes, R.:

Performance of an H_{∞} estimation based damage localization approach in the context of automated Structural Health Monitoring

Proceedings of the 9th European Workshop on Structural Health Monitoring (2018)

Wester, T.; Traphan, D.; Gülker, G.;

Peinke, J.:

Percolation: Statistical description of a spatial and temporal highly resolved boundary layer transition

Progress in Turbulence VI, Proc. iTi Conference in Turbulence, Bertinoro, Springer, 2017

Witha, B.; Vollmer, L.; Steinfeld, G.:

The PALM wind turbine model: An LES tool for modelling wind turbine wakes in the atmospheric boundary layer

Wind Energy Science Conference 2017, Lyngby, Denmark, June 26 - 29, 2017 (oral) (2017)

Witha, B.; Dörenkämper, M.;

Heinemann, D.:

The effect of heterogeneous land-use on the land-sea transition and power production of offshore wind farms

EUROMECH Colloquium 576: Wind farms in complex terrains, Stockholm, Sweden, June 08 - 10, 2016 (oral) (2016)

Witha, B.; Steinfeld, G.; Heinemann, D.:

Turbulent Wake Flow Characteristics Investigated with LES

3rd International Conference Energy & Meteorology, Boulder, Colorado, USA, June 22 - 26, 2015 (oral) (2015)

Witha, B.; Steinfeld, G.; Drüke, S.;

Günther, R.; Schmidt, M.; Heinemann, D.:

WASA – A Wind and Stability Atlas Providing Information on Long-Term Atmospheric Conditions in the Southern North Sea

3rd International Conference Energy & Meteorology, Boulder, Colorado, USA, June 22 - 26, 2015 (oral) (2015)

Wurps, H.; Steinfeld, G.; Heinemann, D.:

Optimization of the Mellor-Yamada scheme in the meso-scale model WRF for offshore wind conditions based on measurements and large eddy simulations

EMS 2016, Trieste, Italy, September 12 - 16, 2016 (oral) (2016)

Wurps, H.; Tambke, J.; Bye, J. A. T.; Wolff, J.-O.; Steinfeld, G.:

Necessary Accuracy of Offshore Wind and Turbulence Measurements for the Improvement of Micrometeorological Models

3rd International Conference Energy & Meteorology, Boulder, Colorado, USA, June 22 -26, 2015 (oral)

Wurps, H.; Steinfeld, G.; Tambke, J.:

Influence of PBL schemes and re-analyses data on wind fields above the North Sea simulated with the meso-scale model WRF

COSMO/CLM/ART User Seminar 2015, Offenbach, Germany, March 06 - 08, 2015 (poster) (2015)

Project Reports

- Achmus, M.; Abdel-Rahman, K.:
Ermittlung des Pfahlgruppeneffektes einer Zweiergruppe offener Stahlrohrpfähle
Project report for Tennet TSO GmbH, November 01, 2016
- Aman, T. Z.; Bastine, D.; Beck, H.; Dörenkämper, M.; van Dooren, M. F.; Friedrichs, W.; Funcke, P. G.; Heinemann, D.; Hieronimus, J.; Kühn, M.; Peinke, J.; Reuter, R.; Schmidt, J.; Schmidt, M.; Schneemann, J.; Steinfeld, G.; Stoevesandt, B.; Trabucchi, D.; Trujillo, J. J.; Vollmer, L.; Voß, S.; Wächter, M. & Witha, B. Kühn, M. & Schneemann, J. (Eds.):
Final report of the research project "Analyse der Abschattungsverluste und Nachlaufbulenzcharakteristika großer Offshore-Windparks durch Vergleich von *alpha ventus* und *Riffgat*"
GW Wakes (2017)
- Bedon, G.; Griebmann, T.; Hansen, K.S., Schröder, K.; Tu, Y.:
Upload of the formatted data (fixed WT) to the database: Work Package 6.1 – Deliverable D61.4,
EU project IRPWIND, pp. 1-40
- Bockholt, S., Voß, S., Bromm, M., Kühn, M., Botasso, C., Campagnolo, F., Heinemann, D.:
Erhöhung des Flächenenergieertrags in Windparks durch avancierte Anlagen- und Parkregelung ("CompactWind")
Final report of the research project (2017)
- Bromm, M.; Heinemann, D.; Kühn, M.; Petrović, V.; Rott, A.; Steinfeld, G.; van Dooren, M.; Vollmer, L.; Voß, S. (Eds.):
Final report of the research project "Erhöhung des Flächenenergieertrags in Windparks durch avancierte Anlagen- und Parkregelung"
CompactWind (2017)
- Drüke, S.; Steinfeld, G.; Schmidt, M.:
Numerical wind and stability atlas for the North Sea
Deliverable D1.3 in EU Project ClusterDesign, pp. 1-148
- Ehrich, S.; Lind, P.; Shrestha, B.; Steinfeld, G.; Tambke, J.; Trujillo, J.J.; Wächter, M.; Vera Tudela, L.; Wurps, H.; Zadorozhnyy, A.; Kühn, M. (Eds.):
Final report of the research project RAVE "Probabilistische Lastbeschreibung, Monitoring und Reduktion der Lasten zukünftiger Offshore-Windenergieanlagen"
OWEA Loads (2017)
- Foglia, A.; Gintautas, T.; Hübler, C.; Schmoor, K.; Sørensen, J.D.:
Report on geotechnical tests with model structures: Work Package 7.2 - D72.2
EU project IRPWIND, pp. 1-43
- Griebmann, T.; Hansen, K.S.; Karimirad, M.; Schröder, K.; Tande, J.O.:
Upload of the formatted data (floating WT) to the database: Work Package 6.1 – Deliverable D61.3
EU project IRPWIND, pp. 1-10
- Häfele, J.; Gebhardt, C.G.; Rolfes, R.:
Innovative design of a hybrid-type jacket for 10MW turbines
Hannover, 2017
- Hansen, M.; Schmidt, B.:
Safety of Offshore Wind Turbines (WP 1)
Marx, S. (ed.): Probabilistic Safety Assessment of Offshore Wind Turbines. Final report of research project PSA-OWEA, pp. 15-28
- Hübler, C., Hofmeister, B.:
Turbine Modeling
14th eawe PhD seminar, Vrije Universiteit Brussel, Belgium, September 18-20, 2018
- Kühn, T.; Altmikus, A.:
AssiSt – BMWi Schlussbericht gemäß NKBF98
Förderkennzeichen: 0325719
- Kühn, M.:
IEA Task 32: Wind Lidar Systems for Wind Energy Deployment (LIDAR)
Final report (2015)
- Kühn, M., Cheng, P.W. (Hrsg.):
Regelung von Offshore-Windparks durch lokale Leistungsprognosen sowie Monitoring der Leistungs- und Belastungscharakteristik (Baltic I)
Final report of the BMWi research project 0325215A, Universität Oldenburg (2015)
- Marx, S.; Hansen, M.; von der Haar, C.; Diederley, J.; Lohaus, L.; Hümme, J.:
Entwicklung und versuchstechnische Erprobung von ermüdungsfesten Gründungskonstruktionen aus Beton für Offshore-Windenergieanlagen
Final report of research project ProBeton (BMW-FKZ 0325670), p. 119
- Meyer Forsting, A.R.; Verelst, D.R.; Merz, K.; Kvittem, M.; Kelma, S.:
Roadmap for offshore design codes: Work Package 6.2 – Deliverable D62.8
EU project IRPWIND, pp. 1-30
- Natarajan, A.; Ehrmann, A.; Hübler, C.; Sørensen, J.D.; Schmoor, K.; Dimitrov, N.; Pfaffel, S.; Faulstich, S.; Gintautas, T.; Wandji, W.N.:
Probabilistic: Work Package – D7 4.2
EU project IRPWIND, pp. 1-111
- Ohlendorf, J.-H.; Rolbiecki, M.; Schmoor, T.; Franke, J.; Ischtschuk, L.:
mapretec – ein Verfahren zur preform-Herstellung durch ebene Ablage für ein räumliches Bauteil als Basis einer automatisierten Prozesskette zur Rotorblattfertigung
Universität Bremen, Institute of integrated Product Development (BIK); SAERTEX GmbH & Co. KG., 2015
- Schmidt, B.; Hansen, M.; Schaumann, P.; Rolfes, R.; Goretzka, J.:
Foundation and Support Structure (WP 4)
Marx, S. (ed.): Probabilistic Safety Assessment of Offshore Wind Turbines. Final report of research project PSA-OWEA, pp. 56-84
- Schröder, K.; Bode, M.:
Design of offshore wind farms – data assimilation: Work Package 6.1 – Deliverable number 61.1
(Definition of conventions and first data structures), EU project IRPWIND, pp. 1-29

Schröder, K.; Berthold, T.:

Design of offshore wind farms – Data assimilation: Work Package 6.1 – Deliverable number 61.2

(Installation of a database), EU project IRPWIND, pp. 1-27

Steinfeld, G.; Özdemir, H.;

Mittelmeier, N.:

Validated wake models (ForWind and ECN)

Deliverable D6.3 in EU Project ClusterDesign, pp. 1-88

Tessmer, J. (Hrsg.):

Smart Blades – Entwicklung und Konstruktion intelligenter Rotorblätter: Teilvorhaben D Windphysik

Final report by DLR, Fraunhofer IWES, ForWind – Universität Hannover, and ForWind – Universität Oldenburg (FKZ 0325601 A/B/C/D)(2016)

Tsiapoki, S.; Krause, T.; Rolfes, R.; Ostermann, J.:

Erweiterung und Erprobung eines Schadensfrüherkennungs- und Eisdetektionssystems für Rotorblätter von Windenergieanlagen

Final report of the research project SHM. Rotorblatt by Institute of Structural Analysis (ISD) and Institut für Theoretische Nachrichtentechnik und Informationsverarbeitung (tnt), Leibniz Universität Hannover. (2016)

von der Haar, C.; Marx, S.:

Auslegung von Suction Buckets in Betonbauweise

Achmus, M. (ed.): Suction Bucket Gründungen als innovatives und montageschallreduziertes Konzept für Offshore-Windenergieanlagen. Final report of research project WindBucket (BMWi-FKZ 0325406B), pp. 151-172

Public Lectures, Articles in Magazines and Other Publications

Achmus, M.:

Design of Foundation Elements for Offshore Wind Energy Converters

Keynote lecture, 15. Int. Conference on Structural and Geotechnical Engineering (ICSGE), Cairo/ Egypt, Dec. 20, 2015

Achmus, M.:

Bearing behavior and design of monopiles used as foundations for offshore wind energy converters

Keynote lecture at the 3rd International Soil-Structure Interaction Symposium, Izmir, Turkey, Oct. 18, 2017

Barth, S.:

Windenergie – zum Stand der Technik und Entwicklungen

Ringvorlesung Umwelt-Technik, Hildesheim, October 21, 2015

Barth, S.:

Excellent wind power research for industrial projects

Invited talk, The Niedersachsen Event at EWEA Offshore 2015, Copenhagen, March 10, 2015

Barth, S.:

TV-Interview

Radio Bremen Buten & Binnen
March 20, 2015

Barth, S.:

TV-Interview

NDR Hallo Niedersachsen
September 15, 2015

Barth, S.:

Von vorwettbewerblicher Unterstützung bis zum Betrieb von Prüfständen für die Industrie

Invited talk, 12th Austrian Wind Energy Symposium, Vienna
March 10, 2016

Barth, S.:

TV-Interview

NDR Hallo Niedersachsen
October 25, 2016

Barth, S.:

Windenergie – zum Stand der Technik und Entwicklungen

Ringvorlesung Umwelt-Technik, Hildesheim, January 12, 2017

Barth, S.:

Presentation "ForWind"

Sommerreise Ministerpräsident Stephan Weil, Oldenburg, June 22, 2017

Barth, S.:

From turbulence to torque – why wind energy needs pre-competitive research and large research infrastructures

Invited talk, 6th international conference on Renewable Power Generation (RPG), Wuhan, China, October 19, 2017

Dörenkämper, M.:

An investigation of the atmospheric influence on spatial and temporal power fluctuations in offshore wind farms

Dr. Hut Verlag, 168 pages (2015)

Kärn, M., Schwarzer, C.:

Praxisbeispiel Windstudium: Lernprozesse in der Weiterbildung als soziale Prozesse gestalten. In: Entwicklung von wissenschaftlichen Weiterbildungsprogrammen im MINT-Bereich

Arnold, M., et al. (Hrsg.), Waxmann-Verlag, Münster, 2017, ISBN: 978-3-8309-3694-7

Kühn, M., Gasch, R., Sundermann, S.:

Kap. 8 Strukturdynamik

In: Gasch, R., Tvele, J., Windkraftanlagen – Grundlagen und Entwurf, 9. Aufl., Springer (2016)

Kühn, M.:

Kap. 16 Offshore-Windparks

In: Gasch, R., Tvele, J., Windkraftanlagen – Grundlagen und Entwurf, 9. Aufl., Springer (2016)

Örlü, R.; Talamelli, A.; Oberlack, M.;

Peinke, J. (Eds.):

Progress in Turbulence VII

Proceedings of the iTi Conference in Turbulence 2016
Springer, 2017, DOI: 10.1007/978-3-319-57934-4

Poppinga, T., Behrendt, T., Schmidt, A. H.:

Kollaborative Entwicklung eines Masterprogramms und verschiedener Zertifikatskurse im modularen Baukastensystem. In Entwicklung von wissenschaftlichen Weiterbildungsprogrammen im MINT-Bereich

Arnold, M., et al. (Hrsg.), Waxmann-Verlag, Münster, 2017, ISBN: 978-3-8309-3694-7

Schmidt, A. H.:

Das Modell des Lehrbaustein-Gitters für MINT-Fächer. Eine neue Art der Erfassung von Lerninhalten. In Entwicklung von wissenschaftlichen Weiterbildungsprogrammen im MINT-Bereich

Arnold, M., et al. (Hrsg.), Waxmann-Verlag, Münster, 2017, ISBN: 978-3-8309-3694-7

Stammler, M.:

Verfahren zum Ermitteln einer Notwendigkeit, einen Schmierzustand eines Rotorblattlagers einer Windkraftanlage zu verbessern, Steuervorrichtung zum Durchführen eines solchen Verfahrens und Windkraftanlage mit einer solchen Steuervorrichtung DE 10 2015 218 659 A1 (2017)

Unger, R.; Gerendt, C.; Daum, B.; Jansen,

E.; Rolfes, R.; Ueing, C.; Englisch, N.;

Sayer, F.; Exner, W.; Mahrholz, T.;

Lorsch, P.; Wierach, P.:

Lebensdauererhöhung und Leichtbauoptimierung durch nanomodifizierte und hybride Werkstoffsysteme im Rotorblatt Forum Industrial Supply – Hannover Messe, 2017, Hannover, Germany

Lectures

Achmus, M.:

Soil Investigation and Foundations for Wind TurbinesHaus der Technik (HdT) Essen,
June 22, 2015

Achmus, M.:

Open questions regarding the bearing behavior of suction bucketsDNV GL Cross-Industry Symposium,
Hamburg,
28 Sept. 2015

Achmus, M.:

On the design of suction-installed foundationsSeminar Research on Offshore Foundations, Imperial College, London,
16 March 2016

Hansen, M.; Bode, M.; Diederley, J.:

Sonderkonstruktionen im MassivbauLeibniz Universität t Hannover,
Winter term 2015/2016

Hansen, M.; Bode, M.; Diederley, J.:

Sonderkonstruktionen im MassivbauLeibniz Universität t Hannover,
Winter term 2016/2017

Hansen, M.; Bode, M; Birkner, D.:

Sonderkonstruktionen im MassivbauLeibniz Universität Hannover,
Winter term 2017/2018

Kühn, M.:

Wind Physics Measurement ProjectCarl von Ossietzky Universität
Summer term 2016

Kühn, M.:

Design of Wind Energy SystemsCarl von Ossietzky Universität
Summer term 2016

Kühn, M.:

Aeroelastic Simulation of Wind TurbinesCarl von Ossietzky Universität
Summer term 2016

Kühn, M.:

Introduction to Engineering PhysicsCarl von Ossietzky Universität
Summer term 2016

Kühn, M.:

Wind Energy UtilisationCarl von Ossietzky Universität
Summer term 2016

Kühn, M.:

Wind Physics Measurement ProjectCarl von Ossietzky Universität
Summer term 2017

Kühn, M.:

Design of Wind Energy SystemsCarl von Ossietzky Universität
Summer term 2017

Kühn, M.:

Aeroelastic Simulation of Wind TurbinesCarl von Ossietzky Universität
Summer term 2017

Kühn, M.:

Introduction to Engineering PhysicsCarl von Ossietzky Universität
Summer term 2017

Kühn, M.:

Wind Physics Student LabCarl von Ossietzky Universität
Summer term 2017

Kühn, M.:

Wind Energy UtilisationCarl von Ossietzky Universität
Summer term 2017

Kühn, M.:

MechanicsCarl von Ossietzky Universität
Winter term 2017/2018

Kühn, M.:

Introduction to Renewable EnergiesCarl von Ossietzky Universität
Winter term 2017/2018

Kühn, M.:

Laboratory Project IICarl von Ossietzky Universität
Winter term 2017/2018

Kühn, M.:

Wind Turbine Design ProjectCarl von Ossietzky Universität
Winter term 2017/2018

Kühn, M.:

Wind Physics Student's LabCarl von Ossietzky Universität
Winter term 2017/2018

Kühn, M.:

Advanced MetrologyCarl von Ossietzky Universität
Winter term 2017/2018

Raasch, S.:

Turbulence IILeibniz Universität Hannover,
Winter term 2015/2016, 2016/2017,
2017/2018

Raasch, S.:

Introduction to simulating flows with LES modelsLeibniz Universität Hannover,
Summer term 2015, 2016, 2017

Thoben, K.-D.:

Technisches Zeichnen KL I-1 / Engineering Drawing KL I-1Universität Bremen,
Winterterm 2015/16 &
Winterterm 2016/17

Thoben, K.-D.:

Anwendung eines 3D-CAD-Systems / Application of 3D-CAD-SystemsUniversität Bremen
Winterterm 2015/16 &
Winterterm 2016/17

Thoben, K.-D.:

Extended Products / Extended ProductsUniversität Bremen
Winterterm 2015/16 &
Winterterm 2016/17

Thoben, K.-D.:

Konstruktionssystematik / Produktentwicklung / Design Methods and ToolsUniversität Bremen
Winterterm 2015/16 &
Winterterm 2016/17

Thoben, K.-D.:

Einführung in die Maschinenelemente KL I-2 / Introduction into Machine Elements KL I-2Universität Bremen.
Sommerterm 2015 & Sommerterm 2016 &
Sommerterm 2017

- Thoben, K.-D.:
Auslegung von Maschinenelementen / Konstruktionsentwurf KL II-1 / Dimensioning of Machine Elements / Engineering Design KL II-1
Universität Bremen
Sommerterm 2015 & Sommerterm 2016 & Sommerterm 2017
- Thoben, K.-D.:
Anwendung und Vergleich von Kreativitätstechniken / Applying and Comparing Creativity Techniques
Universität Bremen Sommerterm 2015 & Sommerterm 2016 & Sommerterm 2017
- Thoben, K.-D.:
CAD-Management und virtuelle Produktentwicklung / CAD Management and Virtual Product Development
Universität Bremen Sommerterm 2015 & Sommerterm 2016 & Sommerterm 2017
- Thoben, K.-D.:
Anwendung von Konstruktionsmethoden / Application of Design Methods
Universität Bremen Sommerterm 2015 & Sommerterm 2016 & Sommerterm 2017
- PhD Theses**
- Dörenkämper, M.:
An investigation of the atmospheric influence on spatial and temporal power fluctuations in offshore wind farms
Ph.D. Thesis
Carl von Ossietzky Universität Oldenburg (2015)
- Herrmann, R.:
Simulation und Regelung von Resonanzversuchsständen zur Untersuchung der Bauteilermüdung
PhD Thesis,
Leibniz Universität Hannover (2017)
- Junk, C.:
Statistical methods for probabilistic wind and wind power forecasting
Ph.D. Thesis
Carl von Ossietzky Universität Oldenburg (2015)
- Kapp, S.:
Lidar-based Reconstruction of Wind Fields and Application for Wind Turbine Control
Ph.D. Thesis
Carl von Ossietzky Universität Oldenburg (2017)
- Kies, A.:
Modelling the influence of demand side management, storage and curtailment on a highly renewable European power system
PhD Thesis,
Carl von Ossietzky Universität Oldenburg (2016)
- Lewandowski, M.:
Entwicklung eines Integrationsmodells zur Zustandserfassung und Optimierung der Instandhaltung komplexer technischer Systeme
PhD Thesis,
Universität Bremen (2016)
- Maier, M.:
Entwicklung einer systematischen Vorgehensweise für bionischen Leichtbau
PhD Thesis,
Universität Bremen (2015)
- Späth, S.:
Statistische Korrektur von Ensemblevorhersagen der regional aggregierten Windleistung
Ph.D. Thesis
Carl von Ossietzky Universität Oldenburg (2015)
- Schmidt, B.:
Kombinierte extreme Einwirkungen für Offshore- Windenergieanlagen
PhD Thesis,
Leibniz Universität Hannover (2017)
- Schmoor, K.A.:
Probabilistische Analyse zum Sicherheitsniveau von Offshore-Gründungspfählen
PhD Thesis,
Leibniz Universität Hannover (2017)
- Thieken, K.:
Geotechnical Design Aspects of Foundations for Offshore Wind Energy Converters
PhD Thesis,
Leibniz Universität Hannover (2015)
- Vollmer, L.:
Influence of atmospheric stability on wind farm control
PhD Thesis,
Carl von Ossietzky Universität Oldenburg (2017)
- von der Haar, C.:
Ein mechanisch basiertes Dehnungsmodell für ermüdungsbeanspruchten Beton
PhD Thesis
Leibniz Universität Hannover (2016)

Diploma, Master, Bachelor, and other Theses

- Ahrens, T.:
Vergleich von Teilsicherheitskonzepten für die Suction-Bucket-Installation
Diploma Thesis,
Leibniz Universität Hannover (2016)
- Albe, R.:
Validierung von Berechnungsmethoden zur Bestimmung der axialen Tragfähigkeit von Offshore-Pfahlgründungen
Master Thesis,
Leibniz Universität Hannover (2016)
- Alemans, L.:
Reliability-based model for steel structures inspection planning
Master thesis
Institute of Physics – Wind Energy Systems, Carl von Ossietzky Universität (2015)
- Al-Madi, N.:
Zur Anwendung von Kombinationsverfahren für Einwirkungen des Hochbaus auf Offshore-spezifische Einwirkungen
Seminar Thesis,
Leibniz Universität Hannover (2016)
- Al-Madi, N.:
Entwurf und Bemessung der Tragkonstruktion einer Windenergieanlage
Master Thesis,
Leibniz Universität Hannover (2017)
- Altenhöner, R.:
Untersuchung zur Anwendbarkeit der p-y Methode für Pfähle großer Durchmesser
Diploma Thesis,
Leibniz Universität Hannover (2015)
- Assam, E. M.:
Feed Forward Control of a 7,5 MW Smart Blades Wind Turbine using a Linear Kalman Filter
Master thesis
Carl von Ossietzky Universität (2017)
- Astudillo, F.:
Assessment of engineering wake models available in WindPro for prediction of energy yield at onshore wind farms
Master thesis
Carl von Ossietzky Universität (2015)
- Barak, E.:
Konstruktion eines Leichtbau-Effektortorrahmens unterstützt durch die Anwendung von FE-Methoden
Master Thesis
Universität Bremen (2016)
- Barnhoorn, J.:
Turbulence Estimation from a Continuous-Wave Scanning Lidar
Master thesis
Carl von Ossietzky Universität (2016)
- Baust, S.:
Global and local FE-Modelling of rotor blade pitch bearings in Ansys and validation of results
Bachelor Thesis,
(2016)
- Bertram, L.:
Untersuchungen zur Anwendbarkeit der p-y Methode für Pfähle großer Durchmesser in geschichteten, nichtbindigen Baugrundverhältnissen
Diploma Thesis,
Leibniz Universität Hannover (2015)
- Besecke, G.:
Korrelationsuntersuchungen an Messzeitreihen von Wind- und Seegangereignissen sowie Dehnungszeitreihen erfasst an einer Jacket-Tragstruktur
Seminar Thesis,
Leibniz Universität Hannover (2016)
- Bill, M.:
Reibwertermittlung zwischen Betonfertigteilen
Project Thesis,
Leibniz Universität Hannover (2017)
- Birkner, D.:
Numerische Untersuchung von Spannungsumlagerungen an einem Schwerkraftfundament infolge Ermüdungsbelastung
Master Thesis,
Leibniz Universität Hannover (2016)
- Bock, H.:
Numerische Untersuchung eines Stahlbetonsegmentturms mit alternativer Fugenausbildung
Master Thesis,
Leibniz Universität Hannover (2017)
- Bock, H.:
Bemessungsmodelle für Segmentfugen von Windenergieanlagen
Bachelor Thesis,
Leibniz Universität Hannover (2017)
- Böhm, M.:
Studie zum Extremlastverhalten von Jacket-Tragstrukturen für Offshore Windenergieanlagen
Bachelor Thesis,
Leibniz Universität Hannover (2016)
- Borgelt, J.:
Numerischen Untersuchungen an einer Muffenverbindung
Bachelor Thesis,
Leibniz Universität Hannover (2017)
Brandt, L.; Gründer, J.; Projahn, S.; Wittfoth, S.:
Intelligentes Lager- und Logistiksystem am Beispiel von Textilrollen zur automatisierten Herstellung von Faser-Kunststoff-Verbundbauteilen
Project Thesis
Universität Bremen (2015)
- Brandt, S.:
Optimierung von Jacket-Tragstrukturen für Offshore-Windenergieanlagen
Bachelor Thesis,
Leibniz Universität Hannover (2015)
- Braun, F.:
Untersuchungen zur erforderlichen Einbindetiefe von Monopiles als Gründungselement für Offshorewindenergieanlagen
Master Thesis,
Leibniz Universität Hannover (2017)
- Budvytyte, E.:
Untersuchungen zum progressiven Rammversagen bei offenen Stahlrohr-rampfpfählen
Master Thesis,
Leibniz Universität Hannover (2015)

- Buß, M.:
Untersuchung zur axialen Pfahltragfähigkeit von Offshore Windenergieanlagen in der Nordsee
Bachelor Thesis,
Leibniz Universität Hannover (2015)
- Carreño, D.:
Optimization of Preventive Maintenance for Onshore Wind Energy Converters
Master thesis
Carl von Ossietzky Universität (2015)
- Dietrich, J.:
Extremlastverhalten von Tragstrukturen für Offshore-Windenergieanlagen unter seismischer Anregung
Bachelor Thesis,
Leibniz Universität Hannover (2017)
- Dörpmund, L.:
Parameterstudie zur Untersuchung der maßgebenden Einflussgröße zur Abschätzung der kritischen Einbindetiefe von Monopiles
Bachelor Thesis,
Leibniz Universität Hannover (2017)
- Fligg, A. M.:
Validation of remotely sensed temperature and humidity profiles against radiosoundings
Master Thesis,
Carl von Ossietzky Universität Oldenburg (2017)
- Frouzakis, N.:
Implementation of virtual LIDARs in LES for wake analysis
Master thesis
Carl von Ossietzky Universität (2017)
- Garr, J.:
Entwicklung einer aktiven Vorrichtung für definierte Bedingungen bei Scherprüfungen von technischen Textilien
Bachelor Thesis
Universität Bremen (2016)
- Gharbaoui, J.:
Optimierung der Genauigkeit von Roboter-Systemen durch integrierte Sensorik
Master Thesis
Universität Bremen (2015)
- Giron, C.:
Optimization of the Wind Energy Production Through Efficient Portfolios
Master thesis
Carl von Ossietzky Universität (2017)
- Goldau, N.:
Analyse von Strömungsnetzberechnungen für Suction Buckets bei geschichtetem und geneigtem Baugrund
Master Thesis,
Leibniz Universität Hannover (2017)
- Grove, S.:
Schadenslokalisierung auf Basis automatisierter Modellanpassung am Beispiel eines Rotorblatts für Windenergieanlagen
Master Thesis,
Leibniz Universität Hannover (2017)
- Hamza, M. I.:
Assessment of different wake tracking methods
Bachelor thesis
Carl von Ossietzky Universität (2017)
- Hempfen, C.:
Shut Down Procedures for Wind Turbines with Smart Blades
Master thesis
Carl von Ossietzky Universität (2016)
- Henkel, M.:
Application of virtual sensing to offshore wind energy converters with jacket substructures
Master Thesis,
Leibniz Universität Hannover (2016)
- Herrera Rodríguez, O. R.:
Analysis of the impact of atmospheric stability on wake meandering Sensitivity of wind resource estimates with the mesoscale model WRF on land surface data
Master Thesis,
Carl von Ossietzky Universität Oldenburg (2015)
- Hieronimus, J.:
Wind speed measurements in an offshore wind farm by remote sensing. A comparison of radar satellite TerraSAR-X and ground-based LiDAR systems
Master thesis
Carl von Ossietzky Universität (2015)
- Iywer, S.:
Assessing and Minimizing the Sampling Errors in Dual-Doppler Remote Sensing Data
Master thesis
Carl von Ossietzky Universität (2016)
- Junge, M.:
Schadenslokalisierung gestützt auf model updating im Zeitbereich am Beispiel eines vorgespannten Betonturmes
Master Thesis,
Leibniz Universität Hannover (2017)
- Klein, F.:
Kollisionssicherheit einer hybriden Substruktur für Offshore Windenergieanlagen
Master Thesis,
Leibniz Universität Hannover (2015)
- Klein, F.:
Skalierbarkeit einer hybriden Substruktur für Offshore-Windenergieanlagen
Seminar Thesis,
Leibniz Universität Hannover (2015)
- Krehl, S.:
Zum Tragverhalten von Sphäroguss und Beton
Master Thesis,
Leibniz Universität Hannover (2016)
- Krüger, S.:
Investigation of the Development of Internal Boundary Layers by Means of Large-Eddy Simulation
Master Thesis,
Carl von Ossietzky Universität Oldenburg (2017)
- Külpmann, A.:
Case Study of mesoscale wind fluctuations during cold air outbreaks
Master Thesis,
Carl von Ossietzky Universität Oldenburg (2017)
- Korthals, F. A.:
Numerische Untersuchungen zum Verbundverhalten von Sphäroguss und Beton
Master Thesis,
Leibniz Universität Hannover (2017)

- Kurka, M.:
Konstruktion eines aktiven Adapters zur Anbindung einer Handhabungseinheit an ein Roboterportalsystem
Bachelor Thesis
Universität Bremen (2015)
- Li, C. S.:
Design of experiment methods for the damage evaluation of floating wind turbines
Bachelor thesis
Carl von Ossietzky Universität (2017)
- Lilje, D.:
Einfluss einer heterogenen Verteilung von Baugrundeigenschaften auf den axialen und lateralen Pfahlwiderstand
Master Thesis,
Leibniz Universität Hannover (2017)
- Martínez, R. A.:
Design and Verification of Risk Management Methodologies for its Application in the Wind Industry
Master thesis
Carl von Ossietzky Universität (2015)
- Menke, R.:
Investigation of the Wake Propagation of a Wind Turbine in Complex Terrain Blades on Lidar Measurements of the Perdigao Experiment
Master Thesis
Carl von Ossietzky Universität (2016)
- Meyer, J.:
Implementierung eines Modells zur Abschätzung des Zugtragverhaltens von Suction Bucket-Gründungen in nichtbindigen Böden
Bachelor Thesis,
Leibniz Universität Hannover (2016)
- Michaely, M.:
Validierung des Ansatzes zur Bestimmung der elastischen Verformung von Monopiles
Diploma Thesis,
Leibniz Universität Hannover (2015)
- Middendorf, J.:
Schubspannungsverteilung in geschliffenen Segmentfugen
Seminar Thesis,
Leibniz Universität Hannover (2017)
- Miesner, E.:
Untersuchung eines Schmelzklebers als Bindersystem in der automatisierten Rotorblattfertigung
Master Thesis
Universität Bremen (2016)
- Miryeganeh, A.:
Off-shore Wind Turbine Tower Control by Applying an Optimal Control Technique
Master thesis
Carl von Ossietzky Universität (2015)
- Müller, F.:
Vergleich von Sensitivitätsanalysen zur Bestimmung signifikanter Parameter bei komplexen Modellen von Windenergieanlagen
Master Thesis,
Leibniz Universität Hannover (2017)
- Niehaus, J.:
Entwicklung einer Vorrichtung zur teilautomatisierten Bestimmung der Biegesteifigkeit von technischen Textilien
Bachelor Thesis
Universität Bremen (2017)
- Orjuela Velasco, J.:
Study on the Low Level Jet events occurring at heights relevant for offshore wind energy converters in the German Bight
Bachelor Thesis,
Carl von Ossietzky Universität Oldenburg (2017)
- Pache, D.:
Anwendung eines vorwärtsgerichteten neuronalen Netzes zur Erweiterung eines SHM-Schemas
Master Thesis,
Leibniz Universität Hannover (2016)
- Plitzner, S.:
Analyse von Drapierwerkzeugkonzepten für die Ablage von Glasfasergelegen in eine Rotorblatt-Hauptform
Master Thesis
Universität Bremen (2015)
- Plut, M.:
A comparison of two approaches for the representation of wind farms in WRF during stable atmospheric conditions
Master thesis
Carl von Ossietzky Universität (2016)
- Prakash, G.:
Investigation of a Condition-Monitoring approach for wind turbine power converters based on insulation resistance measurements
Master thesis
Carl von Ossietzky Universität (2015)
- Recalde, R. F. V.:
Development of an analysis procedure for evaluating dynamic behavior of operational wind turbines using mechanical load measurement data
Master thesis
Carl von Ossietzky Universität (2017)
- Reckweg, L.:
Extraction of Modal Parameters of a Rotor Blade
Bachelor thesis
Carl von Ossietzky Universität (2017)
- Reepschläger, L.:
Systematische Analyse technischer Risiken im Betrieb von Offshore-Windenergieanlagen als Grundlage für die Bewertung des Instandhaltungsprozesses
Bachelor thesis
Carl von Ossietzky Universität (2015)
- Richrath, M.:
Konstruktion komplexer Komponenten einer Handhabungseinheit zur automatisierten Ablage technischer Textilien
Master Thesis
Universität Bremen (2015)
- Roß, A.:
Situational activation of Load Mitigation Concepts for a Commercial Offshore Wind Turbine
Master thesis
Carl von Ossietzky Universität (2017)
- Rowlinson, B.:
Wind Turbine Standstill Instability Analysis
Master thesis
Carl von Ossietzky Universität (2015)

- Rudloff, S.; Schnabel:
Entwicklung einer Einheit zur automatisierten Aufwicklung konfektionierter Fasergelegebahnen
Bachelor Thesis
Universität Bremen (2016)
- Salim Dar, A.:
Wind turbine wake interaction in complex terrain using Large-Eddy Simulation
Master Thesis,
Carl von Ossietzky Universität Oldenburg,
Danish Technical University (2018)
- Sambahamphe, B. S.:
Geographical Information System (GIS) Analysis of Global Wind Atlas Data
Master thesis
Carl von Ossietzky Universität (2017)
- Sangster, M.:
Wind Farm Layout Optimisation for both Loads and Production using Surrogate Wake Models and Automated Optimisation Methods
Master thesis
Carl von Ossietzky Universität (2017)
- Schillebeckx, D.:
Sensitivity Testing and Technical Implementation of Mesoscale Generalization Procedure for the WRF Model
Master thesis
Carl von Ossietzky Universität (2016)
- Schödler, J.:
Identification of wind turbine production losses due to icing using neural networks
Master thesis
Carl von Ossietzky Universität (2017)
- Schröder, L.:
Seecening potential areas and techno-economic assessment of wind farms for the planning of Danish offshore wind energy
Master thesis
Carl von Ossietzky Universität (2016)
- Schwabe, R.:
Aerodynamic Analysis and Optimisation of a Reference Rotor for a 10 MW Offshore Wind Turbine with respect to the Support Structure
Master Thesis
Carl von Ossietzky Universität (2016)
- Seifert, J. K.:
Investigation of the Effect of Wind Direction Dynamics and Measurement Errors on Active Wake
Master thesis
Carl von Ossietzky Universität (2015)
- Selle, J.:
Analyse des Adapterbereiches einer Hybrid-Windenergieanlage
Bachelor Thesis,
Leibniz Universität Hannover (2016)
- Sommer, K.:
Konstruktion eines modularen Ablagesystems für Roboterwerkzeuge
Bachelor Thesis
Universität Bremen (2016)
- Soylu, T.:
Numerische Schädigungsuntersuchung eines Schwerkraftfundamentes infolge Ermüdungsbelastung
Bachelor Thesis,
Leibniz Universität Hannover (2016)
- Steiner, J.:
Analysis of the Effect of Wind Turbine Yaw Misalignment on the Turbine Wake Path by Lidar Wake Tracking
Master thesis
Carl von Ossietzky Universität (2016)
- Stell, L.:
Monitoring der Rotorblätter von Windenergieanlagen im Betrieb
Master Thesis,
Leibniz Universität Hannover (2017)
- Stelljes, P.:
Untersuchung zu großmaßstäblichen Modellversuchen zum axialen Tragverhalten
Master Thesis,
Leibniz Universität Hannover (2015)
- Stindt, D.:
Analyse von Werkzeugkonzepten zur automatisierten Drapierung von Glasfasergelegen in der Rotorblattfertigung
Bachelor Thesis
Universität Bremen (2015)
- Sved, D.:
Konstruktiver Entwurf einer Leichtbau-Handhabungseinheit zur automatisierten Ablage technischer Textilien
Master Thesis
Universität Bremen (2017)
- Syeddykh, D.:
Numerische Untersuchungen zum Einfluss des Installationsvorgangs auf das Zugtragverhalten von offenen Verdrängungspfählen
Master Thesis,
Leibniz Universität Hannover (2016)
- Theuer, F.:
Development of a Pressure Model in the Wake of Wind Turbines
Bachelor thesis
Carl von Ossietzky Universität (2016)
- Troya, J.:
Sensitivity of wind resource estimates with the mesoscale model WRF on land surface data
Bachelor Thesis,
Carl von Ossietzky Universität Oldenburg (2016)
- Tun, L.:
Entwurf eines 145 m hohen Spannbetonturmes für eine Windenergieanlage der 3-MW-Klasse
Seminar Thesis,
Leibniz Universität Hannover (2017)
- Vali, M.:
Controller design for a wind turbine with bend-twist coupled blades
Master thesis
Carl von Ossietzky Universität (2015)
- Vernekar, V.:
Grid codes variant and implementation strategy for country specific requirements
Master thesis
Carl von Ossietzky Universität (2015)
- Vikili Dastjerd, B.:
Entwicklung eines Funktionstestprogramms für das Rotorblattlager der Referenzanlage IWT 7.5-164 und Erstellung eines Algorithmus zur Erzeugung eines beschleunigten Dauertestprogramms.
Master Thesis,
Universität Kassel (2016)

Von Hindte, C.:

**Tragverhalten zyklisch axialbelasteter
Stahlrohrpfähle**

Master Thesis,
Leibniz Universität Hannover (2017)

Wagner, D.:

**Evolution and Properties of Low Level
Jet Events above the Southern North
Sea**

Master Thesis,
Carl von Ossietzky Universität Oldenburg
(2017)

Wegmann, A.:

**Optimierungsmöglichkeiten durch
Augmented Reality in der Instandhal-
tung und im technischen Service**

Bachelor Thesis
Universität Bremen (2017)

Wlodarczyk-Zimny, A.:

**Konzeptioneller Entwurf einer
Bewegungskompensationsplattform
für Windenergieanlagenkomponenten
auf Transportschiffen**

Bachelor Thesis
Universität Bremen (2017)

Zain, J.:

**Degradation of pile loading behaviour
under cyclic axial load**

Master Thesis,
Leibniz Universität Hannover (2016)

Zindler, J.:

**Numerische Untersuchungen zum
Verbundverhalten von Sphäroguss und
Beton**

Seminar Thesis,
Leibniz Universität Hannover (2017)

List of ForWind Staff Members

Abdel-Rahman, Khalid, Dr.-Ing. M.Sc.

Universität Hannover
Institute for Geotechnical Engineering (IGtH)
+49 511 762 2273
khalid@igth.uni-hannover.de

Abulrazek, Abdulkarim, M.Sc.

Universität Oldenburg
Institute of Physics
AG Turbulence, Wind Energy and Stochastics (TWiSt)
+49 441 798 5023
Abdulkarim.abdulrazek@forwind.de

Achmus, Martin, Prof. Dr.-Ing.

Universität Hannover
Institute for Geotechnical Engineering (IGtH)
+49 511 762 4155
achmus@igth.uni-hannover.de

Adler, Johannes, Dipl.-Ing.

Universität Bremen
Institute for Electrical Drives, Power Electronics and Devices (IALB)
+49 421 218-62675
adler@ialb.uni-bremen.de

Akbarzadeh Lalkami, Siamak M.Sc.

Universität Oldenburg
Institute of Physics
AG Energy Meteorology (EnMet)
+49 441 798 5076
siamak.akbarzadeh@forwind.de

Albensoeder, Stefan, Dr.

Universität Oldenburg
Institute of Physics
AG Energy Meteorology (EnMet)
+49 441 798 5075
stefan.albensoeder@forwind.de

Albiker, Johannes, Dipl.-Ing.

Universität Hannover
Institute for Geotechnical Engineering (IGtH)
+49 511 762 4155
albiker@igth.uni-hannover.de

Ambroise, Hugues, M.Sc.

Universität Oldenburg
Institute of Physics
AG Energy Meteorology (EnMet)
+49 441 798 5078
ambroise.hugues@forwind.de

Balzani, Claudio, Dr.-Ing.

Universität Hannover
Institute of Wind Energy Systems (IWES)
+49 511 762 5612
claudio.balzani@iwes.uni-hannover.de

Barth, Stephan, Dr.

ForWind Head Office
+49 441 798 5091
stephan.barth@forwind.de

Basaldella, Marco, M.Sc.

Universität Hannover
Institute for Building Materials Science (IfB)
+49 511 762 3477
m.basaldella@baustoff.uni-hannover.de

Bartschat, Arne

Fraunhofer Institute for Wind Energy Systems (IWES)
+49 471 14290 520
arne.bartschat@iwes.fraunhofer.de

Bastine, David

Universität Oldenburg
Institute of Physics
AG Turbulence, Wind Energy and Stochastics (TWiSt)
+49 441 798 5054
david.bastine@uni-oldenburg.de

Battermann, Dagmar

ForWind Head Office
+49 441 798 5060
dagmar.battermann@forwind.de

Beck, Hauke, M.Sc.

Universität Oldenburg
Institute of Physics
AG Wind Energy Systems (WESys)
+49 441 798 5064
hauke.beck@forwind.de

Behnke, Karsten

Fraunhofer Institute for Wind Energy Systems (IWES)
+49 471 14290 521
karsten.behnke@iwes.fraunhofer.de

Behnken, Christian, M.Sc.

Universität Oldenburg
Institute of Physics
AG Turbulenz, Windenergie and Stochastics (TWiSt)
+49 441 798-5052
christian.behnken@forwind.de

Behrendt, Werner, Dipl.-Ing.

Universität Bremen
Bremen Institute for Metrology, Automation and Quality Science (BIMAQ)
+49 0421 218 64636
wb@bimaq.de

Beltrán, Raúl, M.Sc.

Universität Hannover
Institute for Concrete Construction (IfM)
+49 511 762 2189
beltran@ifma.uni-hannover.de

Berger, Frederik, M.Sc.

Universität Oldenburg
Institute of Physics
AG Wind Energy Systems (WESys)
+49 441 798 5065
frederik.berger@forwind.de

Berthold, Tim, M.Sc.

Universität Hannover
Institute for Risk and Reliability (IRZ)
+49 511 762 17883
berthold@irz.uni-hannover.de

Betcke, Jethro, M.Sc.

Universität Oldenburg
Institute of Physics
AG Energy Meteorology (EnMet)
+49 441 798 3927
jethro.betcke@forwind.de

Birkner, Dennis, M.Sc.

Universität Hannover
Institute for Concrete Construction (IfM)
+49 511 762 3354
birkner@ifma.uni-hannover.de

Bode, Dennis, M.Sc.

Universität Bremen
Institute for Integrated Product Development (BlK)
+49 421 218-64879
dbode@uni-bremen.de

Bode, Matthias, M.Sc.

Universität Hannover
Institute for Risk and Reliability (IRZ)
bode@bauinf.uni-hannover.de

Böske, Lennart, M.Sc.

Universität Hannover
Institute of Meteorology and Climatology
(IMUK)
+49 511 762-3232
boeske@muk.uni-hannover.de

Bohne, Tobias, M.Sc.

Universität Hannover
Institute of Structural Analysis (ISD)
+49 551 762-2859
t.bohne@isd.uni-hannover.de

Brink, Michael, M.Sc.

Universität Bremen
Institute for Integrated Product
Development (BIK)
+49 421 218-64873
brinkm@uni-bremen.de

Bromm, Marc, M.Sc.

Universität Oldenburg
Institute of Physics
AG Wind Energy Systems (WESys)
+49 441 798 5063
marc.bromm@uni-oldenburg.de

Brudler, Evelyn, M.Sc.

Universität Oldenburg
Institute of Physics
AG Wind Energy Systems (WESys)
+49 441 798 5081
evelyn.brudler@forwind.de

Bruns, Marlene, M.Sc.

Universität Hannover
Institute of Structural Analysis (ISD)
+49-511-762-3083
m.bruns@isd.uni-hannover.de

Brunko, Alexander, Dipl.-Ing.

Universität Hannover
Institute for Electrical Drives, Power
Electronics and Devices (IALB)
+49 421-218 62772
a.brunko@uni-bremen.de

Buhr, Renko, M.Sc.

Universität Oldenburg
Institute of Physics
AG Energy Meteorology (EnMet)
+49 441 798 5076
renko.buhr@forwind.de

Chattopadhyay, Kabitri, M.Sc.

Universität Oldenburg
Institute of Physics
AG Energy Meteorology (EnMet)
+49 441 798 5074

Dapperheld, Jörg

Universität Oldenburg
Institute of Physics
AG Turbulence, Wind Energy and
Stochastics (TWiSt)
+49 441 798 3535
joerg.dapperheld@uni-oldenburg.de

Daum, Benedikt, Dipl.-Ing. Dr.

Universität Hannover
Institute of Structural Analysis (ISD)
+49-511-762- 5696
b.daum@isd.uni-hannover.de

Dean, Aamir, Dr.-Ing.

Universität Hannover
Institute of Structural Analysis (ISD)
+49-511-762-4519
a.dean@isd.uni-hannover.de

Decker, André, Dr.-Ing.

Universität Bremen
Institute for Integrated Product
Development (BIK)
+49 421 218-64874
decker@uni-bremen.de

Dibbern, Christoph, M.Sc.

Department of Computing Science
+49 441 798-4482
christoph.dibbern@uni-oldenburg.de

Dollinger, Christoph, M.Sc.

Universität Bremen
Bremen Institute for Metrology,
Automation and Quality Science
(BIMAQ)
+49 421 218 64628
dol@bimaq.de

Dörenkämper, Martin, M.Sc.

Universität Oldenburg
Institute of Physics
AG Energy Meteorology (EnMet)
+49 441 798 5077
martin.doerenkaemper@forwind.de

Dose, Bastian, M.Sc.

Universität Oldenburg
Institute of Physics
AG Turbulence, Wind Energy and
Stochastics (TWiSt)
+49 441 798 5056
bastian.dose@forwind.de

Dubois, Jan, M. Sc.

Universität Hannover
Institute for Steel Construction
+49 511 762-2492
dubois@stahl.uni-hannover.de

Ehrich, Sebastian, Dipl. Phys.

Universität Oldenburg
Institute of Physics
AG Turbulence, Wind Energy and
Stochastics (TWiSt)
+49 441 798 5057
sebastian.ehrich@forwind.de

Ehrmann, Andreas, Dipl.-Ing.

Universität Hannover
Institute of Structural Analysis (ISD)
+49 551 762-17213
a.ehrmann@isd.uni-hannover.de

Eichstädt, Rasmus, Dipl.-Ing.

Universität Hannover
Institute for Steel Construction (IfS)
+49 511 762-5949
eichstaedt@stahl.uni-hannover.de

Ernst, Alexander, Dipl.-Ing.

Universität Bremen
Institute for Electrical Drives, Power
Electronics and Devices (IALB)
+49 421 218-62691
aernst@ilab.uni-bremen.de

Fleischer, Simon, M.Sc.

Universität Bremen
Institute of Automation (IAT)

Forghani, S. Mohsen, M.Sc.

Universität Oldenburg
Institute of Physics
AG Wind Energy Systems (WESys)
+49 441 798 5068
mohsen.forghani@forwind.de

Franke, Jan, Dipl.-Ing.

Universität Bremen
Institute for Integrated Product
Development (BIK)
+49 421 218 64876
j.franke@uni-bremen.de

Friedrichs, Wilm, Dr.-Ing.
 Universität Oldenburg
 Institute of Physics
 AG Wind Energy Systems (WESys)
 +49 441 798 5066
 wilm.friedrichs@forwind.de

Fuchs, André, M.Sc.
 Universität Oldenburg
 Institute of Physics
 AG Turbulence, Wind Energy and
 Stochastics (TWiSt)
 +49 441 798 5023
 andre.fuchs@forwind.de

Gebhardt, Cristian, Dr.-Ing.
 Universität Hannover
 Institute of Structural Analysis (ISD)
 +49 511 762 2859
 c.gebhardt@isd.uni-hannover.de

Gerasch, Wolf-Jürgen, Dipl.-Ing.
 Universität Hannover
 Institute of Structural Analysis (ISD)
 +49 511 762 2247
 wj.gerasch@isd.uni-hannover.de

Gerendt, Christian, M.Sc.
 Universität Hannover
 Institute of Structural Analysis (ISD)
 +49-511-762-2266
 c.gerendt@isd.uni-hannover.de

Gerlach, Tim, Dipl.-Ing.
 Universität Hannover
 Institute for Geotechnical Engineering
 (IGtH)
 +49 511 762 3529
 gerlach@igth.uni-hannover.de

Gharibi, Zeinab, .M.Sc.
 Universität Oldenburg
 Institute of Physics
 AG Turbulence, Wind Energy and
 Stochastics (TWiSt)
 +49 441 798 5055
 gharibi.zeinab@forwind.de

Groke, Holger, Dr.-Ing.
 Universität Bremen
 Institute for Electrical Drives, Power
 Electronics and Devices (IALB)
 +49 421 218-62677
 hgroke@ialb.uni-bremen.de

Gottlieb, Gerrit, M.Sc.
 Universität Hannover
 Institute of Structural Analysis (ISD)
 +49-511-762-3108
 g.gottlieb@isd.uni-hannover.de

Grießmann, Tanja, Dr.-Ing.
 Universität Hannover
 Institute of Structural Analysis (ISD)
 +49 511 762 2247
 t.griessmann@isd.uni-hannover.de

Groß, Günter, Prof. Dr.
 Universität Hannover
 Institute of Meteorology and Climatology
 (IMUK)
 +49 511 762 5408
 gross@muk.uni-hannover.de

Gülker, Gerd, Dr.
 Universität Oldenburg
 Institute of Physics
 AG Turbulence, Wind Energy and
 Stochastics (TWiSt)
 +49 441 798 3511
 gerd.guelker@uni-oldenburg.de

Gutierrez, Monica Almonacid, M.Sc.
 Universität Oldenburg
 Institute of Physics
 AG Wind Energy Systems (WESys)
 +49 441 798 5060
 monica.gutierrez@uol.de

Hadjihosseini, Ali, M.Sc.
 Universität Oldenburg
 Institute of Physics
 AG Turbulence, Wind Energy and
 Stochastics (TWiSt)
 +49 441 798 5043
 ali.hadjihosseini@uni-oldenburg.de

Häfele, Jan, Dipl.-Ing.
 Universität Hannover
 Institute of Structural Analysis (ISD)
 +49 551 762-4208
 j.haeefe@isd.uni-hannover.de

Hähne, Hauke, M.Sc.
 Universität Oldenburg
 Institute of Physics
 AG Turbulence, Wind Energy and
 Stochastics (TWiSt)
 +49 441 798 5054
 hauke.haehne@forwind.de

Hahn, Axel, Prof. Dr.-Ing.
 Universität Oldenburg
 Computing Science, Business Engineering
 +49 441 798 4480
 hahn@offis.de

Hammer, Annette, Dr.
 Universität Oldenburg
 Institute of Physics
 AG Energy Meteorology (EnMet)
 +49 441 798 3545
 annette.hammer@uni-oldenburg.de

Hanf, Michael, Dipl.-Ing.
 Universität Bremen
 Institute for Electrical Drives, Power
 Electronics and Devices (IALB)
 +49 421 218 62795
 michael.hanf@uni-bremen.de

Hansen, Michael, Dr.-Ing.
 Universität Hannover
 Institute for Concrete Construction (IfM)
 +49 511 762 3353
 hansen@ifma.uni-hannover.de

Haselsteiner, Andreas F., M.Sc.
 Universität Bremen
 Institute for Integrated Product
 Development (BIK)
 +49 421 218-64878
 a.haselsteiner@uni-bremen.de

Haunhorst, Frauke, Dipl. Kffr.
 ForWind Head Office
 +49 441 798 5090
 frauke.haunhorst@forwind.de

Heinemann, Detlev, Dr.
 Universität Oldenburg
 Institute of Physics
 AG Energy Meteorology (EnMet)
 +49 441 798 3543
 detlev.heinemann@forwind.de

Heißelmann, Hendrik, Dipl.-Phys.
 Universität Oldenburg
 Institute of Physics,
 AG Turbulence, Wind Energy and Stochastics (TWiSt)
 +49 441 798 3643
 hendrik.heisselmann@uni-oldenburg.de

Henneberg, Joshua, M.Sc.
 Universität Hannover
 Institute for Steel Construction
 +49 511 762-4995
 henneberg@stahl.uni-hannover.de

Herraez Hernandez, Ivan, M.Sc.

Universität Oldenburg
 Institute of Physics
 AG Turbulence, Wind Energy and
 Stochastics (TWiSt)
 +49 441 798 5055
 ivan.herraez.hernandez@uni-oldenburg.de

Herrmann, Ralf, Dr.-Ing.

Universität Hannover
 Institute for Concrete Construction (IfM)
 +49-030-8104-3888
 ralf.herrmann@bam.de

Hesseling, Christina, Dipl.-Phys.

Universität Oldenburg
 Institute of Physics
 AG Turbulence, Wind Energy and
 Stochastics (TWiSt)
 +49 441 798 3514
 christina.hesseling@uni-oldenburg.de

Hieronimus, Julian, M.Sc.

Universität Oldenburg
 Institute of Physics
 AG Wind Energy Systems (WESys)
 +49 441 798 5060
 julian.hieronimus@forwind.de

Hildebrandt, Arndt, Dipl.-Ing.

Universität Hannover
 Franzius-Institute for Hydraulic,
 Waterways and Coastal Engineering
 +49 511 762 2582
 hildebrandt@lufi.uni-hannover.de

Hillers, Bernd, Dipl.-Ing.

ForWind Head Office
 Coordinator
 +49 441 798 5090
 bernd.hillers@forwind.de

Hölling, Agnieszka, Dipl.-Ing.

Universität Oldenburg
 Institute of Physics
 AG Turbulence, Wind Energy and
 Stochastics (TWiSt)
 +49 441 798 3535
 agnieszka.hoelling@mail.uni-oldenburg.de

Hölling, Michael, Dr.

Universität Oldenburg
 Institute of Physics
 AG Turbulence, Wind Energy and
 Stochastics (TWiSt)
 +49 441 798 3951
 michael.hoelling@uni-oldenburg.de

Hörmeyer, Jasmin, M.Sc.

Universität Hannover
 Institute of Structural Analysis (ISD)
 +49 441 798 4703
 j.hoermeyer@isd.uni-hannover.de

Hoffmann, Felix, Dipl.-Ing.

Universität Bremen
 Institute for Electrical Drives, Power
 Electronics and Devices (IALB)
 +49 421 218 62664
 felix.hoffmann@uni-bremen.de

Hofmann, Lutz, Prof. Dr.-Ing. habil.

Universität Hannover
 Institute for Electric Power Systems (IEE)
 +49 511 762 2801
 hofmann@iee.uni-hannover.de

Hofmeister, Benedikt, M.Eng.

Universität Hannover
 Institute of Structural Analysis (ISD)
 +49 511 762 17213
 b.hofmeister@isd.uni-hannover.de

Hogreve, Sebastian, Dipl.-Ing.

Universität Bremen
 Bremen Institute for Mechanical
 Engineering (bime)
 +49 421 218 64837
 hogreve@bime.de

Hohmann, Claas, Dipl.-Ing.

Universität Bremen
 Institute of Automation (IAT)

Holzke, Wilfried, Dipl.-Ing.

Universität Bremen
 Institute for Electrical Drives, Power
 Electronics and Devices (IALB)
 +49 421 218-62675
 holzke@ialb.uni-bremen.de

Homeyer, Tim, Dipl.-Phys.

Universität Oldenburg
 Institute of Physics
 AG Turbulence, Wind Energy and
 Stochastics (TWiSt)
 +49 441 798 3514
 tim.homeyer@uni-oldenburg.de

Hübler, Clemens, M.Sc.

Universität Hannover
 Institute of Structural Analysis (ISD)
 +49 511 762 2885
 c.huebler@isd.uni-hannover.de

Jahjough, Mahmoud, Dr.-Ing.

Universität Hannover
 Institute of Structural Analysis (ISD)
 +49 511 762-4939
 m.jahjough@isd.uni-hannover.de

Jansen, Eelco, Dr.

Universität Hannover
 Institute of Structural Analysis (ISD)
 +49-511-762-17425
 e.jansen@isd.uni-hannover.de

Jauken, Helge, M.Sc.

Universität Hannover
 Institute of Structural Analysis (ISD)
 +49-511-762-2885
 h.jauken@isd.uni-hannover.de

Junk, Constantin, M.Sc.

Universität Oldenburg
 Institute of Physics
 AG Energy Meteorology
 +49 441 798 5079
 constantin.junk@forwind.de

Kärn, Moses

ForWind Head Office
 +49 441 798 5082
 moses.kaern@forwind.de

Kaminski, Nando, Prof. Dr.-Ing.

Institute for Electrical Drives,
 Power Electronics and Devices (IALB)
 +49 421 218 62660
 nando.kaminski@uni-bremen.de

Kampers, Gerrit Malte, M.Sc.

Universität Oldenburg
 Institute of Physics
 AG Turbulence, Wind Energy and
 Stochastics (TWiSt)
 +49 441 798 3455
 gerrit.kampers@forwind.de

Kanani, Farah, Dipl.-Met.

Universität Hannover
 Institute of Meteorology and Climatology
 (IMUK)
 +49 511 762-3232
 kanani@muk.uni-hannover.de

Kelma, Sebastian, Dipl.-Ing.

Universität Hannover
 Institute for Steel Construction (IfS)
 +49 511 762-4139
 kelma@stahl.uni-hannover.de

Kidambi Sekar, Anantha Padmanabhan, M.Sc.

Universität Oldenburg
Institute of Physics
AG Wind Energy Systems (WESys)
+49 441 798 5065
anantha.kidambi@forwind.de

Kies, Alexander, M.Sc.

Universität Oldenburg
Institute of Physics
AG Energy Meteorology (EnMet)
+49 441 798-5078
alexander.kies@forwind.de

Knigge, Christoph, Dr.

Universität Hannover
Institute of Meteorology and Climatology (IMUK)
+49 511 762 3232
knigge@muk.uni-hannover.de

Kraft, Martin, Dipl.-Ing.

Universität Oldenburg
Institute of Physics,
AG Wind Energy Systems (WESys)
+49 441 798-5065
martin.kraft@uni-oldenburg.de

Krause, Thomas, Dipl.-Ing.

Universität Hannover
Institute for Information Processing (tnt)
+49 511 762 5052
kraus @tnt.uni-hannover.de

Krishnappa, Likith, M.Sc.

Universität Bremen
Institute for Integrated Product
Development (BIK)
+49-421 218 64861
likith@uni-bremen.de

Kröger, Lars, M.Sc.

Universität Oldenburg
Institute of Physics,
AG Turbulence, Wind Energy and
Stochastics (TWiSt)
+49 441 798 3535
lars.kroeger@forwind.de

Krüger, Sonja, M.Sc.

Universität Oldenburg
Institute of Physics
AG Energy Meteorology (EnMet)
+49 441 798 5074
sonja.krüger@forwind.de

Kühn, Martin, Prof. Dr. Dipl.-Ing.

Universität Oldenburg
Institute of Physics,
AG Wind Energy Systems (WESys)
+49 441 798 5061
martin.kuehn@forwind.de

Kuhfuss, Bernd, Prof. Dr.-Ing.

Universität Bremen
Bremen Institute for Mechanical
Engineering (bime)
+49 421 218-64800
kuhfuss@bime.de

Kuhnle, Bernd, Dipl.-Ing.

Universität Oldenburg
Institute of Physics,
AG Wind Energy Systems (WESys)
+49 441 798 5064
bernd.kuhnle@forwind.de

Lang, Walter, Prof. Dr.-Ing.

Universität Bremen
Institute for Microsensors, - actuators
and -Systems (IMSAS)
+49 421 218-62602
wlang@imsas.uni-bremen.de

Lind, Pedro, M.Sc.

Universität Oldenburg
Institute of Physics
AG Turbulence, Wind Energy and
Stochastics (TWiSt)
+49 441 798 5090
pedro.lind@forwind.de

Löw, Kathrin, Dipl.-Ing.

Universität Hannover
Institute for Steel Construction (IfS)
Tel.: +49 511 762 3540
loew@stahl.uni-hannover.de

Lohaus, Ludger, Univ.-Prof. Dr.-Ing.

Universität Hannover
Institute for Building Materials Science
(IfB)
+49 511 762 3722, 2990
lohaus@baustoff.uni-hannover.de

Lohmann, Gerold, Dipl. Hydrol.

Universität Oldenburg
Institute of Physics
+49 441 798-3577
gerald.lohmann@uni-oldenburg.de

Maas, Oliver

Universität Hannover
Institute of Meteorology and Climatology
(IMUK)
maas@muk.uni-hannover.de

Marx, Steffen, Prof. Dr.-Ing.

Universität Hannover
Institute for Concrete Construction (IfM)
+49 511 762 3352
marx@ifma.uni-hannover.de

Martens, Susanne, M.Sc.

Universität Hannover
Institute of Structural Analysis Vibrations
Department, AG Acoustics
+49 441 798 4703
s.martens@isd.uni-hannover.de

Matzat, Sebastian, M.Sc.

Universität Bremen
Institute of Automation (IAT)

Mehrens, Anna Rieke, M.Sc.

Universität Oldenburg
Institute of Physics
AG Energy Meteorology (EnMet)
+49 441 798 5079
anna.mehrens@forwind.de

Meints, Irene

Universität Oldenburg
Institute of Physics
AG Wind Energy Systems (WESys)
+49 441 798-5060
irene.meints@uni-oldenburg.de

Menck, Oliver

Fraunhofer Institute for Wind Energy
Systems (IWES)
+49 471 14290 523
oliver.menck@iwes.fraunhofer.de

Mertens, Axel, Prof. Dr.-Ing.

Universität Hannover
Institute for Drive Systems and Power
Electronics (IAL)
+49 511 762 2471
mertens@ial.uni-hannover.de

Michels, Kai, Prof. Dr.-Ing.

Universität Bremen
Institute of Automation (IAT)
+49 421 218 62500
michels@iat.uni-bremen.de

Mörz, Tobias, Prof. Dr.

Universität Bremen
Center for Marine Environmental Sciences
(MARUM)
+49 421 218 65840
tmoerz@marum.de

Moriße, Marcel

Universität Hannover
Institute for Drive Systems and Power
Electronics (IAL)

Munk, Johannes, M.Sc.

Universität Oldenburg
Institute of Physics
AG Energy Meteorology (EnMet)
+49 441 798 5074
johannes.munk@forwind.de

Neuhaus, Lars Kristian, M.Sc.

Universität Oldenburg
Institute of Physics
AG Turbulence, Wind Energy and
Stochastics (TWiSt)
+49 441 798 5024
lars.neuhaus@uol.de

Neunaber, Ingrid, M.Sc.

Universität Oldenburg
Institute of Physics
AG Turbulenz, Windenergie and
Stochastics (TWiSt)
+49 441-798-3455
ingrid.neunaber@forwind.de

Neuweiler, Insa, Prof. Dr.

Universität Hannover
Institute of Fluid Mechanics and Environ-
mental Physics in Civil Engineering
+49 511 762 3567
neuweiler@hydromech.uni-hannover.de

Oetting, Heike

Universität Oldenburg
Institute of Physics
AG Turbulence, Wind Energy and
Stochastics (TWiSt)
+49 441-798-3455
heike.oetting@forwind.de

Ohlendorf, Jan-Hendrik, Dipl.-Ing.

Universität Bremen
Institute for Integrated Product
Development (BIK)
+49 421 218 64876
johlendorf@uni-bremen.de

Oneschkow, Nadja, Dr.-Ing.

Universität Hannover
Institute for Building Materials Science
(IfB)
+49 511 762 3105
n.oneschkow@baustoff.uni-hannover.de

Orlik, Bernd, Prof. Dr.-Ing.

Universität Bremen
Institute for Electrical Drives, Power
Electronics and Devices (IALB)
+49 421 218 62680
orlik@ialb.uni-bremen.de

Pache, Dorian, M.Sc.

Universität Hannover
Institute of Structural Analysis (ISD)
+49 511 762 3083
d.pache@isd.uni-hannover.de

Pawletta, Peter

ForWind Head Office
+49 441 798 5087
peter.pawletta@forwind.de

Peinke, Joachim, Prof. Dr.

Universität Oldenburg
Institute of Physics
AG Turbulence, Wind Energy and
Stochastics (TWiSt)
+49 441 798 3536
peinke@uni-oldenburg.de

Penner, Nikolai, M.Sc.

Universität Hannover
Institute of Structural Analysis (ISD)
+49 551 762-4273
n.penner@isd.uni-hannover.de

Perrone, Francesco, M.Sc.

Universität Oldenburg
Institute of Physics
AG Wind Energy Systems (WESys)
+49 441 798 5063
francesco.perrone@uni-oldenburg.de

Peters, Jan-Hendrik, MSc.

Universität Bremen
Institute for Electrical Drives, Power
Electronics and Devices (IALB)
+49 421 218 62674
j.peters@uni-bremen.de

Petrovic, Vlaho, Dr.

Universität Oldenburg
Institute of Physics
AG Wind Energy Systems (WESys)

+49 441-798-5068
vlaho.petrovic@forwind.de

Pierl, Dennis, Dipl.-Ing.

Universität Bremen
Institute of Automation (IAT)

Poland, Kathleen, Dipl.-Eng.

Universität Oldenburg
Institute of Physics
AG Wind Energy Systems (WESys)
+49 441 798 5065
kathleen.poland@forwind.de

Poll, Gerhard, Prof. Dr.-Ing.

Universität Hannover
Institute for Machine Design and
Tribology (IMKT)
+49 511 762 2416
poll@imkt.uni-hannover.de

Ponick, Bernd, Prof. Dr.-Ing.

Universität Hannover
Institute for Drive Systems and Power
Electronics (IAL)
+49 511 762 2571
ponick@ial.uni-hannover.de

Preihs, Stefan, Dr.-Ing.

Universität Hannover
Institute of Communications Technology
(ikt)
+49 511 762 2819
stephan.preihs@ikt.uni-hannover.de

Prestel, Isabelle, M.Sc.

Universität Oldenburg
Institute of Physics
AG Energy Meteorology (EnMet)
+49 441-798-5079
isabelle.prestel@forwind.de

Puczyłowski, Jarosław, M.Sc.

Universität Oldenburg
Institute of Physics
AG Turbulence, Wind Energy and
Stochastics (TWiSt)
+49 441 798 3643
jaroslaw.puczyłowski@forwind.de

Pyei Phyo, Lin, M.Sc.

Universität Oldenburg
Institute of Physics
AG Turbulence, Wind Energy and
Stochastics (TWiSt)
+49 441 798 3455
phei.phyo.lin@uol.de

Raasch, Siegfried, apl. Prof. Dr.

Universität Hannover
 Institute of Meteorology and Climatology
 (IMUK)
 +49 511 762 3253
 raasch@muk.uni-hannover.de

Raba, Alexander, Dipl.-Ing.

Universität Hannover
 Institute for Steel Construction (IfS)
 +49 511 762-4975
 raba@stahl.uni-hannover.de

Rademacher, Lisa, M.Sc.

Universität Oldenburg
 Institute of Physics
 AG Turbulenz, Windenergie und
 Stochastics (TWiSt)
 +49 441-798-3455
 lisa.rademacher@forwind.de

Radulovic, Luka, M.Sc.

Universität Hannover
 Institute for Steel Construction (IfS)
 +49 511 762 17212
 radulovic@stahl.uni-hannover.de

Rahimi, Hamid, M.Sc.

Universität Oldenburg
 Institute of Physics
 AG Turbulence, Wind Energy and
 Stochastics (TWiSt)
 +49 441 798 5016
 hamid.rahimi@forwind.de

Reck, Martin, M.Sc.

Universität Oldenburg
 Institute of Physics
 AG Wind Energy Systems (WESys)
 +49 441 798 3560
 martin.reck@forwind.de

Redecker, Marc Allan, Dipl.-Ing.

Universität Bremen
 Institute for Integrated Product
 Development (BIK)
 +49 421 218-64877
 maalre@uni-bremen.de

Reichel, Juliane, Dr.

ForWind Head Office
 +49 441 798 5085
 juliane.reichel@forwind.de

Reinke, Nico, Dipl.-Phys.

Universität Oldenburg
 Institute of Physics
 AG Turbulence, Wind Energy and
 Stochastics (TWiSt)
 +49 441 798 3455
 nico.reinke@uni-oldenburg.de

Reuter, Andreas, Prof. Dr.-Ing.

Universität Hannover
 Institute of Wind Energy Systems
 +49 511 762 4712
 andreas.reuter@iwes.uni-hannover.de

Reuter, Rainer, Dr.

Universität Oldenburg
 Institute of Physics
 AG Marine Physics
 +49 441 798 3522
 rainer.reuter@uni-oldenburg.de

Richrath, Marvin, M.Sc.

Universität Bremen
 Institute for Integrated Product
 Development (BIK)
 +49 421 218-64875
 richrath@uni-bremen.de

Rinn, Philip, Dipl.-Phys.

Universität Oldenburg
 Institute of Physics
 AG Turbulence, Wind Energy and
 Stochastics (TWiSt)
 +49 441 798 5052
 philip.rinn@uni-oldenburg.de

Rockel, Stanislav, Dipl.-Phys.

Universität Oldenburg
 Institute of Physics
 AG Turbulence, Wind Energy and
 Stochastics (TWiSt)
 +49 441 798 3455
 stanislav.rockel@uni-oldenburg.de

Rolfes, Raimund, Prof. Dr.-Ing. habil.

Universität Hannover
 Institute of Structural Analysis (ISD)
 +49 511 762 3867
 r.rolfes@isd.uni-hannover.de

Roschen, Julian, M.Sc.

Universität Bremen
 Institute of Automation (IAT)

Rott, Andreas, Dipl.-Math.

Universität Oldenburg
 Institute of Physics
 AG Wind Energy Systems (WESys)
 +49 441 798-5064
 andreas.rott@uni-oldenburg.de

Rzeczkowski, Patrick, Dipl.-Ing.

Universität Hannover
 Institute for Building Materials Science
 (IfB)
 +49 511 762 4206
 p.rzeczkowski@baustoff.uni-hannover.de

Saathoff, Jann-Eike, M.Sc.

Universität Hannover
 Institute for Geotechnical Engineering
 (IGtH)
 +49 511 762 3808
 saathoff@igth.uni-hannover.de

Sander, Aljoscha, M.Sc.

Universität Bremen
 Institute for Integrated Product
 Development (BIK)
 +49 421 218-64867
 alsander@uni-bremen.de

Schack, Tobias, M.Sc.

Universität Hannover
 Institute for Building Materials Science
 (IfB)
 +49 511 762 5243
 t.schack@baustoff.uni-hannover.de

Schäfer, Dominik, Dipl.-Ing.

Universität Hannover
 Institute for Geotechnical Engineering
 +49 511 762 3736
 schaefer@igth.uni-hannover.de

Schaumann, Peter, Prof. Dr.-Ing.

Universität Hannover
 Institute for Steel Construction (IfS)
 +49 511 762 3781
 schaumann@stahl.uni-hannover.de

Schendel, Alexander, Dipl.-Ing.

Universität Hannover
 Ludwig-Franzius-Institute (LuFI)
 +49 511 762 2592
 schendel@lufi.uni-hannover.de

Schleich, Florian

Fraunhofer Institute for Wind Energy
 Systems (IWES)
 +49 471 14290 524
 florian.schleich@iwes.fraunhofer.de

Schlurmann, Torsten, Prof. Dr.-Ing.
 Universität Hannover
 Franzius-Institute for Hydraulic,
 Waterways and Coastal Engineering
 +49 511 762 19021
 schlurmann@fi.uni-hannover.de

Schmidt, Andreas, Dipl.-Ing.
 Universität Oldenburg
 Institute of Physics
 AG Wind Energy Systems (WESys)
 +49 441 798 5086
 andreas.schmidt@forwind.de

Schmidt, Boso, Dipl.-Ing.
 Universität Hannover
 Institute for Concrete Construction (IfM)
 +49 511 762 3355
 schmidt@ifma.uni-hannover.de

Schmidt, Michael, Dipl.-Phys.
 Universität Oldenburg
 Institute of Physics
 AG Wind Energy Systems (WESys)
 +49 441 798 5086
 AG Energy Meteorology (EnMet)
 +49 441 798 5074

Schmietendorf, Katrin, M.Sc.
 Universität Oldenburg
 Institute of Physics
 AG Turbulenz, Windenergie and
 Stochastics (TWiSt)
 +49 441 798-5054
 katrin.schmietendorf@forwind.de

Schmoor, Kirill, Dipl.-Ing.
 Universität Hannover
 Institute for Geotechnical Engineering
 (IGtH)
 +49 511 762 5106
 schmoor@igth.uni-hannover.de

Schneemann, Jörg, Dipl.-Phys.
 Universität Oldenburg
 Institute of Physics
 AG Wind Energy Systems (WESys)
 +49 441 798 5062
 joerge.schneemann@forwind.de

Schneider, Sebastian, Dipl.-Ing.
 Universität Hannover
 Institute for Concrete Construction (IfM)
 +49 511 762 3359
 schneider@ifma.uni-hannover.de

Scholle, Niklaas, Dipl.-Ing.
 Universität Hannover
 Institute for Building Materials Science
 (IfB)
 +49 511 762 3258
 n.scholle@baustoff.uni-hannover.de

Schottler, Jannik, M.Sc.
 Universität Oldenburg
 Institute of Physics
 AG Turbulenz, Windenergie and
 Stochastics (TWiSt)
 +49 441 798-5090
 jannik.schottler@forwind.de

Schramm, Matthias, M.Sc.
 Universität Oldenburg
 Institute of Physics
 AG Turbulenz, Windenergie and
 Stochastics (TWiSt)
 +49 441 798-5090
 matthias.schramm@forwind.de

Schröder, Christian, Dipl.-Ing.
 Universität Hannover
 Institute for Geotechnical Engineering
 (IGtH)
 +49 511 762 4152
 schroeder@igth.uni-hannover.de

Schröder, Karsten, Dr.
 Universität Hannover
 Institute of Structural Analysis (ISD)
 +49 511 762 2885
 k.schroeder@isd.uni-hannover.de

Schüttler, Jochen, Dr.-Ing.
 Universität Bremen
 Institute of Automation

Schwack, Fabian
 Universität Hannover
 Institute for Machine Design and
 Tribology (IMKT)
 +49 471 14290 524
 schwack@imkt.uni-hannover.de

Schwarzer, Christoph, Dipl.-Oek.
 ForWind Head Office
 +49 441 798 5084
 christoph.schwarzer@forwind.de

Schyska, Bruno, M.Sc.
 Universität Oldenburg
 Institute of Physics
 AG Energy Meteorology (EnMet)
 +49 441 798 5079
 bruno.schyska@forwind.de

Seidel, Elke
 ForWind Head Office
 +49 441 798 5092
 elke.seidel@forwind.de

Seifert, Janna, M.Sc.
 Universität Oldenburg
 Institute of Physics
 AG Wind Energy Systems (WESys)
 +49 441-798-5036
 janna.kristina.seifert@uol.de

Segelken, Katharina, M.A.
 ForWind Head Office
 +49 441 798 5088
 katharina.segelken@forwind.de

Segelken, Lars
 Universität Oldenburg
 Institute of Physics
 +49 441 798-5074
 lars.segelken@forwind.de

Seume, Jörg, Prof. Dr.-Ing.
 Universität Hannover
 Institute of Turbomachinery and Fluid
 Dynamics (TFD)
 +49 511 762 2733
 seume@tfd.uni-hannover.de

Shah, Syed Muzaher Hussain, M.Sc.
 Universität Oldenburg
 Institute of Physics
 AG Turbulenz, Windenergie and
 Stochastics (TWiSt)
 +49 441-798-5067
 syed.muzaher.hussain.shah@uol.de

Shirzadeh, Rasoul, M.Sc.
 Universität Oldenburg
 Institute of Physics
 AG Wind Energy Systems (WESys)
 +49 441-798-5060
 rasoul.shirzadeh@forwind.de

Shrestha, Binita, M.Sc.
 Universität Oldenburg
 Institute of Physics
 AG Wind Energy Systems (WESys)
 +49 441-798-5063
 binita.shrestha@forwind.de

Singh, Piyush M.Sc.
 Universität Oldenburg
 Institute of Physics
 AG Turbulenz, Windenergie and
 Stochastics (TWiSt)
 +49 441-798-5024
 piyush.singh@forwind.de

Sonnenschein, Michael, Prof. Dr.
 Universität Oldenburg
 Department of Computing Science
 +49 441 798 2750
 michael.sonnenschein@uni-oldenburg.de

Sorg, Michael, Dipl.-Ing.
 Universität Bremen
 Bremen Institute for Metrology,
 Automation and Quality Science (BIMAQ)
 +49 421 218 64620
 sor@bimaq.de

Späth, Stephan, Dipl.-Met.
 Universität Oldenburg
 Institute of Physics
 AG Energy Meteorology (EnMet)
 +49 441 798 5079
 stephan.spaeth@forwind.de

Stammler, Matthias
 Fraunhofer Institute for Wind Energy
 Systems (IWES)
 +49 471 14290 522
 matthias.stammler@iwes.fraunhofer.de

Steinfeld, Gerald, Dr.
 Universität Oldenburg
 Institute of Physics
 AG Energy Meteorology (EnMet) &
 AG Turbulence, Wind Energy and
 Stochastics (TWiSt)
 +49 441 798 5073
 gerald.steinfeld@forwind.de

Tambke, Jens, Dipl.-Phys.
 Universität Oldenburg
 Institute of Physics
 AG Energy Meteorology (EnMet)
 +49 441 798 5072
 jens.tambke@forwind.de

Terceros, Mauricio, M.Sc.
 Universität Hannover
 Institute for Geotechnical Engineering
 (IGtH)
 +49 511 762 4153
 terceros@igth.uni-hannover.de

Thieken, Klaus, Dipl.-Ing.
 Universität Hannover
 Institute for Geotechnical Engineering
 (IGtH)
 +49 511 762 4153
 thieken@igth.uni-hannover.de

Thoben, Klaus-Dieter, Prof. Dr.-Ing. habil.
 Universität Bremen
 Institute for Integrated Product
 Development (BIK)
 +49 421 218 50005
 tho@biba.uni-bremen.de

Tomann, Christoph, Dipl.-Ing.
 Universität Hannover
 Institute for Building Materials Science
 (IfB)
 +49 511 762 3719
 c.tomann@baustoff.uni-hannover.de

Trabucchi, Davide, M.Sc.
 Universität Oldenburg
 Institute of Physics
 AG Wind Energy Systems (WESys)
 +49 441 798 5062
 davide.trabucchi@forwind.de

Tracht, Kirsten, Prof. Dr.-Ing.
 Universität Bremen
 Bremen Institute for Mechanical Enginee-
 ring (bime)
 +49 421 218 64840
 tracht@bime.de

Traphan, Dominik, Dipl.-Phys.
 Universität Oldenburg
 Institute of Physics, AG Turbulence, Wind
 Energy and Stochastics (TWiSt)
 +49 441 7983 514
 dominik.traphan@uni-oldenburg.de

Trei, Wilke, M.Sc.
 Universität Oldenburg
 Institute of Physics
 AG Energy Meteorology (EnMet)
 +49 441-798-5077
 wilke.trei@forwind.de

Trujillo, Juan José, M.Sc.
 Universität Oldenburg
 Institute of Physics
 AG Wind Energy Systems (WESys)
 +49 441 798 5062
 juan.trujillo@forwind.de

Tsiapoki, Stavroula, Dipl.-Ing.
 Universität Hannover
 Institute of Structural Analysis
 +49 551 762-8063
 s.tsiapoki@isd.uni-hannover.de

Ungurán, Robert. Dipl.-Ing.
 Universität Oldenburg
 Institute of Physics
 AG Wind Energy Systems (WESys)
 +49 441 798 5064
 robert.unguran@forwind.de

Vali, Mehdi, M.Sc.
 Universität Oldenburg
 Institute of Physics
 AG Wind Energy Systems (WESys)
 +49 441 798-5063
 mehdi.vali@uni-oldenburg.de

van Dooren, Marijn, M.Sc.
 Universität Oldenburg
 Institute of Physics
 AG Wind Energy Systems (WESys)
 +49 441 798 5064
 marijn.vandooren@forwind.de

Valldecabres Sanmartin, Laura, M.Sc.
 Universität Oldenburg
 Institute of Physics
 AG Wind Energy Systems (WESys)
 and AG Energy Meteorology (EnMet)
 +49 441-798-5064
 laura.valldecabres@forwind.de

Varasteh, Kamaloddin, M.Sc.
 Universität Bremen
 Institute for Integrated Product
 Development (BIK)
 +49 421 218-64872
 kavasteh@uni-bremen.de

Vera-Tudela Carreno, Luis Enrique, M.Sc.
 Universität Oldenburg
 Institute of Physics
 AG Wind Energy Systems (WESys)
 +49 441 798 5063
 luis.vera.tudela@forwind.de

Vollmer, Lukas, M.Sc.
 Universität Oldenburg
 Institute of Physics
 AG Energy Meteorology (EnMet)
 +49 441 798 5079
 lukas.vollmer@forwind.de

von Bremen, Lueder, Dr.
 Universität Oldenburg
 Institute of Physics
 AG Energy Meteorology (EnMet)
 +49 441 798 5071
 lueder.von.bremen@forwind.de

Vorspel, Lena, M.Sc.

Universität Oldenburg
Institute of Physics,
AG Turbulence, Wind
Energy and Stochastics (TWiSt)
+49 441 798 5056
lena.vorspel@uni-oldenburg.de

Voss, Stephan M.Sc.

Universität Oldenburg
Institute of Physics
AG Wind Energy Systems (WESys)
+49 441 798 5065
stephan.voss@uni-oldenburg.de

Wächter, Matthias, Dr.

Universität Oldenburg
Institute of Physics
AG Turbulence, Wind Energy and Stochastics (TWiSt)
+49 441 798 5051
matthias.waechter@uni-oldenburg.de

Wahl, Benjamin, M.Sc.

Universität Oldenburg
Institute of Physics
AG Turbulenz, Windenergie and
Stochastics (TWiSt)
+49 441-798-5090
benjamin.wahl@forwind.de

Weber, Simon

Universität Hannover
Institute for Drive Systems and Power
Electronics (IAL)

Wernitz, Stefan, M.Sc.

Universität Hannover
Institute of Structural Analysis (ISD)
+49 511 762 4273
s.wernitz@isd.uni-hannover.de

Wester, Tom, M.Sc.

Universität Oldenburg
Institute of Physics
AG Turbulenz, Windenergie and
Stochastics (TWiSt)
+49 441 798-5023
tom.wester@forwind.de

Witha, Björn, Dipl.-Met.

Universität Oldenburg
Institute of Physics
AG Energy Meteorology (EnMet)
+49 441 798 5075
bjoern.witha@forwind.de

Wolff, Miriam, Dipl.-Inform.

Universität Oldenburg
Institute of Physics
AG Energy Meteorology (EnMet)
+49 441 798 5092
miriam.wolff@forwind.de

Wurps, Hauke, M.Sc.

Universität Oldenburg
Institute of Physics
AG Energy Meteorology (EnMet)
+49 441 798 5092
hauke.wurps@forwind.de

Yassin, Khaled, M.Sc.

Universität Oldenburg
Institute of Physics
AG Turbulenz, Windenergie and
Stochastics (TWiSt)
+49 441 798-5058
khaled.Yassin@forwind.de

Zack, Charis

ForWind Head Office
+49 441 798 5081
charis.zack@forwind.de

Zhao, Shumian, M.Sc.

Universität Oldenburg
Institute of Physics
AG Turbulenz, Windenergie and
Stochastics (TWiSt)
+49 441 798-5055
shumian.zhao@forwind.de

Zorn, Christian, Dipl.-Ing.

Universität Bremen
Institute for Electrical Drives, Power
Electronics and Devices (IALB)
+49 421 218 62669
czorn@uni-bremen.de

Imprint

Publisher

ForWind – Center for Wind Energy Research
of the Universities of Oldenburg, Hannover and Bremen

Executive Board

Prof. Dr. Martin Kühn
Prof. Dr.-Ing. Bernd Orlik
Prof. Dr. Joachim Peinke
Prof. Dr.-Ing. habil. Raimund Rolfes
Prof. Dr.-Ing. Peter Schaumann
Prof. Dr.-Ing. Klaus Dieter Thoben

Address ForWind Head Office

Carl von Ossietzky University of Oldenburg
W33 - WindLab
Küpkersweg 70, 26129 Oldenburg
+49 441 798-5090
info@forwind.de
www.forwind.de

Editorial Coordination

Dr. Stephan Barth
Jana Stone

Photos

ForWind

Layout

Dagmar Weinreich-Brunner