



# Annual Report 2013/2014

---

## GREETING

Wind energy is a prime example of a multidisciplinary and interdisciplinary field of science and engineering. Consequently technical and scientific challenges and problems can only be addressed successfully by teams, which are made of experts covering all relevant scientific disciplines. Presently such teams incorporating state of the art research and test facilities carry out the better wind energy projects, both on a national and international level.

ForWind, a collaborative network for wind energy research of the universities of Oldenburg, Hannover and Bremen, has been established in a spirit of interdisciplinary approaches in wind energy research. The mix of various skills, laboratory facilities and – sometimes non-traditional – scientific approaches has proven to be a long lasting and successful concept. This is reflected by the remarkable growth of ForWind as a research community during the first decade of its existence. ForWind now is a leading partner in many international projects and platforms. On the national side ForWind is a crucial partner of the German Research Alliance Wind Energy, a voluntarily established association of the German Aerospace Centre DLR, the Fraunhofer Institute of Wind Energy & Energy Systems Technology IWES and ForWind.

This annual report, covering the period 2013 and 2014 describes the most important research activities and its funding resources. The signing of the cooperation framework agreement of the three ForWind universities, DLR and IWES in January 2013 has been the starting point of a unique partnership. The institutions involved, with their rather different profiles, have been searching for synergy effects continuously, coordinating their projects, and presenting their successes jointly. In this way the Research Alliance Wind Energy has become a very attractive provider of research services to wind energy stakeholders. Within just two years the Alliance could convincingly demonstrate that this has not been a fake promise, but a very effective way of joint research. I was delighted to see that already in November 2014 the five northern German states awarded the North-German Science Award to the German Research Alliance Wind Energy.

Another joyful event was the celebration of ForWind's 10<sup>th</sup> anniversary in spring 2014. Hundreds of colleagues, partners and friends met in Oldenburg to celebrate this particular point in time. On that occasion I felt proud having had the opportunity to chair ForWind's Scientific Advisory Board as of its embryonic phase. I am looking forward to an even more exiting period of wind energy research and technology developments in the years to come.

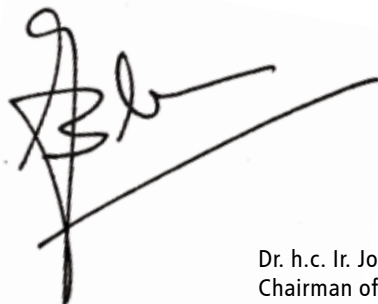

Dr. h.c. Ir. Jos Beurskens  
Chairman of the ForWind Advisory Board

## PREFACE

The years 2013 and 2014 were marked by the expansion of ForWind's strategic cooperations, the start and inauguration of new research buildings and infrastructures, and by the festive review of successful 10 years.

A remarkable alliance was formed in January 2013, when the German Aerospace Center (DLR), Fraunhofer IWES and the three universities behind ForWind signed the framework cooperation agreement of the new German Research Alliance Wind Energy (FVWE). An unprecedented strategic alliance, bringing together more than 600 wind energy researchers and unique research infrastructures. The three partners DLR, ForWind and Fraunhofer IWES agreed to bundle their competences and resources and to coordinate their future wind energy research activities.

FVWE kicked-off with the start of the Smart Blades project. Funded by approximately 12 million EUR by the Federal Ministry for Economic Affairs and Energy (BMWi), the project connected the respective expertises and looked into the future of rotor blades developments. Although the DLR, ForWind, and Fraunhofer IWES are very different in nature, the cooperation took off from the very beginning – leveraging and multiplying the efforts of each individual researcher. Less than two years later, the exceptional and successful cooperation within FVWE was awarded with the North German Science Award – a prize endowed with 50,000 EUR from the five northern German federal states. We are honoured and grateful to this prestigious acknowledgement.

In the reporting period, two new research infrastructures have been added to ForWind's portfolio. The test center for support structures Hanover (TTH) was completed and inaugurated. This unique facility will allow for a new dimension of research within the field of wind energy civil engineering, setting ForWind's experts in Hanover apart from any other group. The construction of another unique research infrastructure started in Oldenburg, where a laboratory for turbulence and wind energy systems will be established, which includes a large turbulence wind tunnel dedicated to wind energy research. We are very grateful to the Federal Government and the State Government of Lower Saxony for providing the generous funding of those new facilities.

Next to looking forward it was also time to look back. The celebration of ForWind's 10th anniversary was a wonderful occasion to meet and discuss with esteemed, current and new partners, friends, colleagues, and supporters from the entire wind energy sector. The development of ForWind would not have been possible without you. Thus, thank you all very much!

We are especially grateful to the State of Lower Saxony for its continued support. This forms the basis from which we develop new research aspects leading to further applied projects and developments with our partners from the industry. The successive developments of joint research projects with industrial partners are mainly financed by the Federal Ministry for Economic Affairs and Energy (BMWi) or directly through industrial co-operations as has been documented in this report.

We would like to thank all ForWind personnel for their commitment to the center and their outstanding contributions to its success, our business and research partners for many fruitful joint efforts, and the members of ForWind's advisory board for their always stimulating work.



Prof. Dr.-Ing. habil. Raimund Rolfes  
Academic Speaker

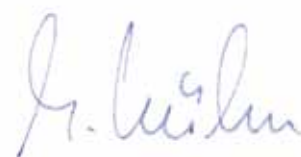

Prof. Dr. Martin Kühn  
Deputy Speaker

## CONTENT

Greeting

Preface

### The Organization

• Executive Board _____	8
• Advisory Board _____	9
• Research Institutes _____	9
• Associated Members of ForWind _____	9

### Projects

#### WIND AS A RESOURCE

• Forwind – Small-Scale Wind Field Modelling / Large-Eddy Simulation _____	10
• Turbulence Test Facility for Artificially Wind Fields Generated by an Active Grid _____	14
• Parallel Computing Cluster for CFD and Wind Turbine Modeling _____	16
• Turbulence Test Facility for Artificially Wind Fields Generated by an Active Grid _____	18
• A Toolbox for Offshore Wind Farm Cluster Design _____	20
• Analysis of the Shadowing Effects and Wake Turbulence Characteristics of Large Offshore Wind Farms by Comparison of »alpha ventus« and »Riffgat« (GW Wakes) _____	24
• EERA-DTOC European Energy Research Alliance – Design Tools for Offshore Wind Farm Cluster _____	28
• Energy-Weather Forecasting and Analysis (E-Ways) _____	30
• IEA Wind Annex 32 – Wind Lidar Systems for Wind Energy Deployment _____	34
• WindScanner.eu – The European WindScanner Facility (Preparatory Phase Project) _____	37
• Development of Nacelle-Based Lidar Technology for Performance Measurement and Control of Wind Energy Converters _____	38
• Generation of Realistic Turbulent In-Flow Conditions by an Active Grid – Stochastic Analysis of The Resulting Force Dynamics on 2D Segments of Airfoils with Active Control Units _____	42
• Traceable Acquisition of Meteorological Data _____	44

#### SUPPORT STRUCTURES

• Predicting Underwater Noise due to Offshore Pile Driving ("BORA") _____	46
• HyproWind: Realistic Underwater Sound Scenarios Based on Forecast Modelling and Monitoring Regarding Piling Noise During Wind Farm Construction in the German North Sea _____	48
• Further Development and Testing of the Big Bubble Curtain (BBC) to Reduce Hydro Noise Pollution in Offshore Pile Driving _____	50
• Development of a Program for the Design of Offshore Piles (IGtH-Pile) _____	52
• Cyclic Degradation of Axially Loaded Piles (2013) _____	54
• Cyclic Degradation of Axially Loaded Piles (2014) _____	56
• Large-Size Bolts II – Experimental and Analytical Assessment of the Fatigue Strength of Bolts With Large Dimensions under Consideration of Boundary Layer Effects _____	58
• WindBucket – Suction Bucket Foundations as Innovative and Installation Noise Reducing Concept for Offshore Wind Energy Converters _____	60

• GROWup – Grouted Joints for Offshore Wind Energy Converters Under Reversal Axial Loadings and Upscaled Thicknesses _____	62
• HyConCast – Hybrid Substructure of High Strength Concrete and Ductile Iron Castings for Offshore Wind Turbines _____	64
• ProBeton – Development and Experimental Testing of Fatigue-Resistant Concrete Foundations for Offshore Wind Turbines _____	66
• Life Time – Research on Support Structures in the Offshore Test Site alpha ventus – GIGAWIND <i>life</i> _____	68
• MaRINET – Marine Renewables Infrastructure Network for Emerging Energy Technologies _____	70
• MaRINET – Marine Renewables Infrastructure Network _____	72

#### WIND POWER SYSTEMS

• INFLOW-Noise _____	74
• Measuring Method for the Aeroacoustic Optimization of Wind Turbine Airfoils _____	76
• Laser-based Contact Pattern Analysis _____	78
• Optical Field Measurements of Rotor Blade Deformations _____	80
• Thermographic Boundary Layer Visualization of Wind Turbine Rotor Blades in Operation _____	82
• Model Wind Turbines for Experimental Studies _____	84
• Smart Blades – Development and Design of Intelligent Rotor Blades _____	86
• A Risk Analysis and Management Tool for Offshore Wind Energy Projects and Operation _____	94
• mapretec _____	96
• BladeMaker _____	98
• Enhancing the Availability and Quality Optimization of Drive Train Components and Gears in Wind Energy Systems _____	100
• Non-destructive and Reliable Real-time Detection of Thermal Damages in Grinding Processes _____	102
• Silicon Carbide Power Electronics Technology for Energy Efficient Devices (SPEED) _____	104
• GeCoLab – 1.2 MW Test Bench for Generators and Converters _____	108
• Probabilistic Safety Assessment of Offshore Wind Turbines _____	110
• OWEA Loads – Probabilistic Loads Description, Monitoring and Reduction for the Next Generation of Offshore Wind Energy Converters _____	112
• "Baltic I": Control of Offshore Wind Farms by Local Wind Power Prediction as Well as by Power and Load Monitoring _____	114
• Compactwind: Increase of the Overall Energy Yield Per Area at Sites Due to the Utilization of Advanced Single Turbine and Wind Farm Control Strategies _____	116
• IRPWIND – Integrated Research Programme on Wind Energy _____	118
• INNWIND.EU – Innovative Wind Conversion Systems (10-20MW) for Offshore Applications _____	122
• Stochastic Processes _____	128
• preInO _____	130
• SAMS Save Automation of Maritime Systems _____	131
• Critical Systems Engineering for Socio-Technical Systems _____	132

#### WIND ENERGY INTEGRATION

• PhD Program on "System Integration of Renewable Energies" _____	134
• Smart Nord _____	136
• Control of Wind Power Stations as a Fictitious Turbine-Generator-System _____	138
• Wind Power Ramp Event Prediction with Support Vector Machines _____	142
• Cooperative Demand Response in the Pacific Northwest: Mitigating Wind Power Ramp Events using a Distributed Control Concept _____	144

## STRUCTURAL HEALTH MONITORING

- Monitoring SBJ: Monitoring Suction Bucket Jacket \_\_\_\_\_ 146
- SHM Rotorblatt: System for Early Damage and Ice Detection for Rotor Blades of Offshore Wind Turbines \_\_\_\_\_ 148

## Qualification

- European Wind Energy Master (EWEM) – Erasmus Mundus Master Course \_\_\_\_\_ 150
- Master Programme on Wind Energy Engineering \_\_\_\_\_ 152
- Continuing Studies Programme Wind Energy Technology and Management \_\_\_\_\_ 154
- Continuing Studies Programme Offshore Wind Energy \_\_\_\_\_ 156
- mint.online: Certificate Programme in Advanced Wind Energy (AWE) \_\_\_\_\_ 158
- ForWind-Academy \_\_\_\_\_ 160
- Job and Education Fair "zukunftsenergien nordwest" 2014 \_\_\_\_\_ 161

## ForWind – Events 2013

- ForWind Course of Lectures \_\_\_\_\_ 162
- Hannover Messe 2013 \_\_\_\_\_ 164
- German Unity Day / Tag der Deutschen Einheit 2013 \_\_\_\_\_ 166
- Research Alliance for Wind Energy Signing of the Cooperation Agreement \_\_\_\_\_ 168
- Research Alliance for Wind Energy – First Research Colloquium \_\_\_\_\_ 169
- Research Alliance for Wind Energy Meeting with Federal Minister for the Environment, Nature Conservation, Building and Nuclear Safety Peter Altmaier \_\_\_\_\_ 170
- European Academy of Wind Energy – Head Office in Oldenburg \_\_\_\_\_ 171
- Selection of International Events and Visits \_\_\_\_\_ 171

## ForWind – Events 2014

- ForWind Course of Lectures \_\_\_\_\_ 172
- Hannover Messe 2014 \_\_\_\_\_ 174
- Anniversery \_\_\_\_\_ 176
- Research Alliance for Wind Energy is awarded the "Norddeutsche Wissenschaftspreis 2014" \_\_\_\_\_ 177
- Testing Towers and Foundations – Opening of the Wind Energy Test Centre for Support Structures (Testzentrum für Tragstrukturen, TTH) \_\_\_\_\_ 178
- International Wind Engineering Conference 2014 – Support Structures and Electrical Systems – (IWEC 2014) \_\_\_\_\_ 182
- Research Alliance for Wind Energy at WindEnergy Hamburg \_\_\_\_\_ 184
- Global Wind Day \_\_\_\_\_ 185
- Coordination Office ForWind at Leibniz Universität Hannover Summary of 2013 and 2014 \_\_\_\_\_ 186

## Documentation

### PUBLICATION LIST

Peer Reviewed Articles _____	188
Articles, Conference Proceedings, Conference Contributions _____	190
Public Lectures, Articles in Magazines and Other Publications _____	198
Lectures _____	199
Project Reports _____	202
PhD Theses _____	202
Diploma, Master and Bachelor Theses _____	202
LIST OF FORWIND STAFF MEMBERS _____	208
IMPRINT _____	216

## The Organization

ForWind, the Center for Wind Energy Research of the Universities of Oldenburg, Hannover, and Bremen combines scientific know-how with research geared towards the industry. ForWind bundles the competencies of the three universities and is an adept industry contact. The administrative office of ForWind is located in Oldenburg.

ForWind was founded in 2004 through the support of the Ministry for Science and Culture of Lower Saxony.

Since 2006, a formal agreement of the Universities of Oldenburg and Hannover exists to form a corporate research center as a joint institution. The University of

Bremen joined in 2009. What continues to make ForWind unique in Germany is that it is a university research center serving to pass along its broad spectrum of expertise to the industry by way of cooperating projects. Within the industry, ForWind has established itself as a competent research partner.



Prof. Dr.-Ing. Bernd Orlik



Prof. Dr.-Ing. habil. Raimund Rolfes



Prof. Dr.-Ing. Klaus-Dieter Thoben



Prof. Dr. Martin Kühn



Prof. Dr. Joachim Peinke



Prof. Dr.-Ing. Peter Schaumann

### Executive Board

ForWind is led by a six member executive board consisting of two members of the Carl von Ossietzky Universität Oldenburg, the Leibniz Universität Hannover and the Universität Bremen respectively. All members have equal authority.

The current executive board is made up of

Prof. Dr.-Ing. habil. Raimund Rolfes (Academic Speaker),  
Prof. Dr. Martin Kühn (Deputy Speaker),

Prof. Dr.-Ing. Klaus-Dieter Thoben,  
Prof. Dr.-Ing. Bernd Orlik,  
Prof. Dr. Joachim Peinke,  
Prof. Dr.-Ing. Peter Schaumann.



## Advisory Board

### Chairman:

Beurskens, Jos, Dr. h.c.  
Energy research Centre of the Netherlands  
(ECN)

### Members:

Hermsmeier, Jörg, Dr.-Ing.  
EWE Aktiengesellschaft

Meier, Klaus, Dr.  
wpd AG

Nachbaur, Karin, Dr.  
The Senator for Education and Science of  
Bremen

Schroeder, Hans, Dr.-Ing.  
Ministry for Science and Culture of Lower  
Saxony

Schubert, Matthias  
REpower Systems AG

Ritterbach, Benedikt, Dr.-Ing.  
Salzgitter Mannesmann Forschung GmbH

Tworuschka, Hartmut, Dr.-Ing.  
HOCHTIEF Construction AG

Weigel, Lars  
SGL Rotec GmbH & Co. KG

### Guests:

Drechsler, Rolf, Prof. Dr.  
University of Bremen

Hulek, Klaus, Prof. Dr.  
Leibniz Universität Hannover

Simon, Babette, Prof. Dr.  
Carl von Ossietzky Universität  
Oldenburg

## Research Institutes

The following institutes and research groups belonging to the Universities of Oldenburg, Hannover and Bremen are active in ForWind:

- Bremen Institute for Metrology, Automation and Quality Science – BIMAQ, University of Bremen, Prof. Dr.-Ing. Gert Goch
- Department of Computing Science, Environmental Informatics, University of Oldenburg, Prof. Dr. Michael Sonnenschein
- Franzius Institute of Hydraulics, Waterways and Coastal Engineering, Leibniz Universität Hannover, Prof. Dr.-Ing. habil. Torsten Schlurmann
- Institute of Building Materials Science, Leibniz Universität Hannover, Prof. Dr.-Ing. Ludger Lohaus
- Institute of Concrete Construction, Leibniz Universität Hannover, Prof. Dr.-Ing. Steffen Marx
- Institute for Drive Systems and Power Electronics, Leibniz Universität Hannover, Prof. Dr.-Ing. Axel Mertens and Prof. Dr.-Ing. Bernd Ponick
- Institute for Electrical Drives, Power Electronics and Devices – IALB, University of Bremen, Prof. Dr.-Ing. Bernd Orlik and Prof. Dr.-Ing. Nando Kaminski
- Institute of Electric Power Systems, Leibniz Universität Hannover, Prof. Dr.-Ing. Lutz Hofmann
- Institute of Fluid Mechanics and Environmental Physics in Civil Engineering, Leibniz Universität Hannover, Prof. Dr. Insa Neuweiler
- Institute for Integrated Product Development, University of Bremen, Prof. Dr.-Ing. Klaus-Dieter Thoben

- Institute of Machine Elements and Engineering Design, Leibniz Universität Hannover, Prof. Dr.-Ing. Gerhard Poll
- Institute of Physics, AG Energy Meteorology, University of Oldenburg, Dr. Detlev Heinemann
- Institute of Physics, AG Marine Physics, University of Oldenburg, Dr. Rainer Reuter
- Institute of Physics, AG Turbulence, Wind Energy and Stochastics – TWIST, University of Oldenburg, Prof. Dr. Joachim Peinke
- Institute of Physics, AG Wind Energy Systems – WE-Sys, University of Oldenburg, Prof. Dr. Martin Kühn
- Institute for Steel Construction, Leibniz Universität Hannover, Prof. Dr.-Ing. Peter Schaumann
- Institute for Geotechnical Engineering Leibniz Universität Hannover, Prof. Dr.-Ing. Martin Achmus
- Institute for Structural Analysis, Leibniz Universität Hannover, Prof. Dr.-Ing. habil. Raimund Rolfes
- Institute of Turbomachinery and Fluid Dynamics-TFD, Leibniz Universität Hannover, Prof. Dr.-Ing. Jörg Seume
- Institute of Meteorology and Climatology, AG PALM, Leibniz Universität Hannover, Prof. Dr. Siegfried Raasch
- Information Systems and Management Institute – ISMI, Leibniz Universität Hannover, Prof. Dr. Michael H. Breitner

## Associated Members of ForWind:

Institute of Machine Elements and Machine Design,  
Prof. Dr.-Ing. Berthold Schlecht

# Forwind – Small-Scale Wind Field Modelling / Large-Eddy Simulation

Carl von Ossietzky Universität Oldenburg  
Institute of Physics, Energy Meteorology  
Group

Hugues Ambroise, Martin Dörenkämper,  
Sonja Drüke, Robert Günther, Sophie Jan-  
kowski, Lars Segelken, Michael Schmidt,  
Gerald Steinfeld, Elisabeth Stütz, Lukas  
Vollmer, Björn Witha, Hauke Wurps,  
Detlev Heinemann

Funding: Ministry for Science and Culture  
of the Federal State of Lower Saxony

Ref.Nr. N.A.

Duration: 12/2009 – 11/2015

## Introduction

Wind energy converters are operating the main part of their lifetime in the atmospheric boundary layer (ABL). The ABL is the bottom layer of the troposphere that is in contact with the surface of the earth. Flow conditions in the ABL are characterized by turbulence and turbulent motions in the ABL cover depending on the situation scales from some millimeters to some thousand meters. Especially under unstable stratification turbulence in the ABL can be vigorous, while under stable stratification turbulence in the ABL has often a more intermittent character. Besides the stability also the roughness of the underlying surface and the topography play a key role for the turbulence in the ABL. As turbulence causes loads on wind turbines a better understanding of atmospheric turbulence can help to optimize the design of wind turbines with regards to the expected turbulence conditions at a certain site.

Wind energy converters interact with and modify the flow in the ABL. The wake of a wind turbine is characterized by a reduced velocity compared to that of the ambient

flow and by additional turbulence caused e.g. by the strong shear of wind speed in the transition region between wake and ambient flow.

Besides measurements turbulence resolving numerical models are required in order to gain a better knowledge on flow conditions in the ABL and within wind farms. Turbulent motions in the ABL extend over a too wide range of scales in order to be accessible for an investigation with the means of direct numerical simulation. Large-eddy simulation (LES), in which the bulk of the turbulent motions are explicitly resolved and the small-scale turbulence is parameterized, is still the state-of-the-art for in-depth analyses of turbulent flows in the ABL. Due to the limited computational resources available the flow at the rotor blades cannot be resolved explicitly if also the whole ABL is simulated and parameterizations are required in order to account for the effect of wind turbines on the atmospheric flow.

The small scale wind field modelling team in the energy meteorology group of ForWind is using the LES model PALM [1] in order to study the interaction between atmospheric flows for different stratifications, surfaces and topographies and wind energy converters. Different wind turbine parameterizations have been implemented into the LES code PALM and these parameterizations are continuously further developed. The final objective of the team is to transfer the knowledge gained from simulations with the pure research tool PALM into improved parameterizations for models used in the wind energy business, such as wind farm parameterizations for mesoscale models or improvements for engineering wake models.

## Project Description

### Accounting for wind turbines in the large eddy simulation model PALM

Different wind turbine models have been implemented into the LES model PALM by staff from the energy meteorology group of ForWind and were available for extensive testing in 2013. The available models include different types of actuator disc approaches, an actuator line approach, an enhanced actuator disc model with rotation and finally also an enhanced actuator line approach, in which the aerodynamic forces acting on the rotor blade segments are obtained by coupling the large-eddy simulation model PALM with an aeroelastic code such as FLEX or FAST.

The results obtained with the different models implemented in PALM have extensively been compared to each other for different wind farms in the North and Baltic Sea as well as for imaginary wind farms and presented on different national and international conferences in 2013. Major results were that with regard to the mean flow the results of actuator line model and enhanced actuator disc model were comparable to each other, although the enhanced actuator disc model consumes only a fraction of the computing time required for simulations with the actuator line model. Especially in the near wake region the simple actuator disc approaches show results deviating from those of the more complex models, while in the far wake region, only minor differences remain. Depending on the problem to be analysed and taking into account the limited available computer resources different parametrizations might be the most suitable one to solve the problem studied. For simulations of a few number of wind turbines the actuator line model coupled with an aeroelastic code might be the best choice, while wind farms of moderate size can still be simulated with the enhanced actuator disc model. Finally, the simple actuator disc approaches are

applicable to first studies of the flow conditions within large wind farms as well as behind wind farms. The enhanced actuator disc model was e.g. used to study the impact of atmospheric stability on the recovery of wakes within wind farms. The wind turbine models implemented in PALM are continuously verified and improved. One example is e.g. the implementation of different tip-loss correction models into the actuator line and enhanced actuator disc model.

It is worth mentioning that a participation in the IEA task 31 “Wakebench” is one strategy followed at ForWind to achieve a validation of the LES model PALM for wind energy applications.

#### Development of wind farm control strategies

Different strategies have been suggested in literature to control the power output of a wind farm. Typically, these control strategies would aim at an increased power output of the whole wind farm and reduced loads on the wind turbines in the wind farm. While one suggestion to control the wind farm is to reduce the extraction of energy from the wind by the wind turbines in the first row of the wind farm, another suggestion is to deflect the wakes by yawing of the wind turbines. In order to allow for investigations of the potential of the second method the enhanced actuator disc model was further developed by allowing also yawing and tilting of the turbines. The further developed model is now used to study the dependency of yawing strategies on impact factors such as the atmospheric stability.

#### Improvement of the engineering wake model FLAP

ForWind’s in-house engineering wake model, the Farm Layout Program (FLaP) [2] has been reactivated. Extensive comparisons of model results and measurements have been done for the wind farm Baltic I. Improvements made to the code allow e.g. for the simulation of wind farms with wind turbines in different operational modes. This is one prerequisite for the investigation of the potential of the first wind farm control strategy mentioned above. One objective of the application of LES models is to gain knowledge on the flow conditions within offshore wind farms and to use this knowledge to improve engineering wake models. A necessary step before any improvement can be aimed at is to compare between the results of the LES model PALM and the current version of

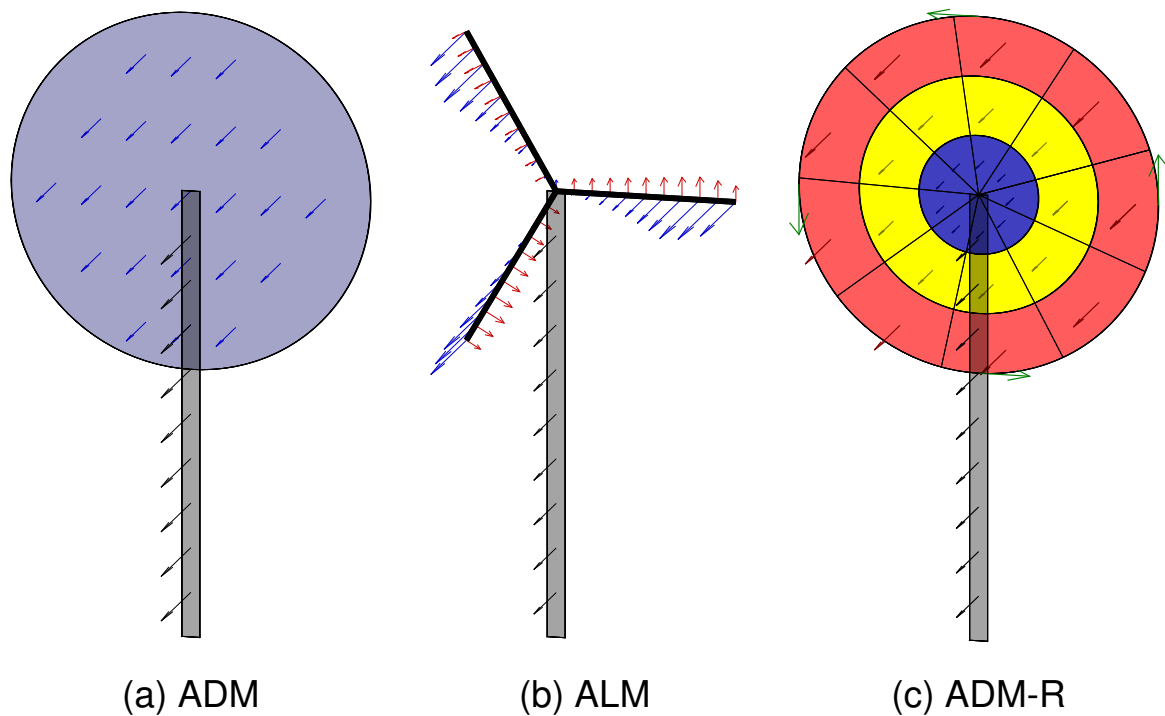

Figure 1: Sketch showing the additional forces in the Navier-Stokes equations when the actuator disc model (a), the actuator line model (b) or the enhanced actuator disc model with rotation (c) is used.

the engineering wake model FLaP in order to see where improvements of the simpler engineering model might be required. Results of such a comparison were presented in an oral presentation during the Annual Meeting of the European Meteorological Society in Reading in 2013. The agreement between the results of the different models was rather poor. One possible reason is the variability of the wind direction which has a huge impact on the size of the wake deficit but that could not successfully be reproduced in the engineering wake model. There is the urgent need for a comprehensive validation of the LES model results before they can be used for a further development of the simpler models. Besides data from the IEA task 31 “Wakebench”, especially data from the LiDAR measurements of ForWind’s WE-Sys group are used for that purpose.

#### Using data from large-eddy simulations for an improved wind farm model for meso-scale models

Wind speeds derived from satellite observations of the state of the sea surface indicate that huge wind farms might cause a velocity deficit that can still be detected tens of kilometers downstream of the wind farm. There is an urgent demand for models that allow for estimating the shadowing of a wind farm by neighbouring wind farms. Therefore, e.g. wind farm parameterizations have been developed for meso-scale models. At ForWind, the LES model PALM has been used to check the validity of assumptions made in the so-called Fitch wind farm parameterization available in the meso-scale model WRF [3]. The actuator disc approach implemented in PALM has been used in order to simulate the flow conditions downstream of the wind farm

alpha ventus. The results of the LES model have been spatially averaged to a grid with a grid size of 3.5 km<sup>2</sup> in the two horizontal directions in order to mimic mesoscale modeling. In contrast to the results of the Fitch model the PALM results showed that the wind farm wake is dependent on the wind direction. The simplifying assumption that all wind turbines extract the same amount of energy from the flow as made in the Fitch model does not lead to satisfying results for the wind farm wake in the case studied. The LES data is currently used to improve the Fitch parameterization.

#### Wind energy converters in complex terrain

In 2013, a first project has started in which the interaction of an atmospheric flow and wind energy converters in complex terrain are intended to be studied. The first objec-

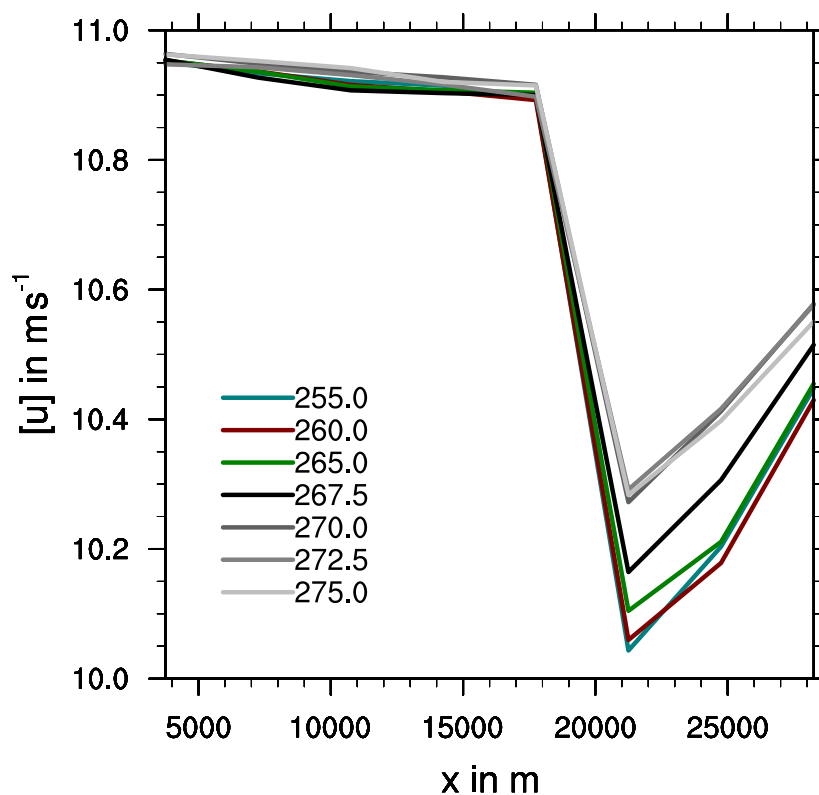

Figure 2: Hub height wind speed horizontally averaged over an area of 3500 m<sup>2</sup> vs. distance from the inflow boundary. The wind turbines of the wind farm alpha ventus are situated somewhere between  $x=19500$  and  $x=23000$  m depending on the wind direction.

tive is to reproduce results from measurements in a wind tunnel experiment with focus on the flow over a simple sinusoidal hill with the LES model PALM. These comparisons do not include wind turbines. The topography model in PALM allows for approximating topography by a step-like function. Once the reproduction of the measured flow conditions is successful, wind turbines will be added to the simulations and the interaction between wind turbines and terrain effects will be studied in detail.

#### **Detection of requirements for an improvement of planetary boundary layer schemes in meso-scale models**

Meso-scale simulation models seem to be a promising tool to derive the long-term atmospheric conditions at certain sites. By comparison between long-term simulations and measurements at on- and offshore sites it is investigated how well the mesoscale simulations actually are. In contrast to earlier studies the focus is on height levels up to 300 m, which might become relevant for future generations of wind turbines. A special focus of our work is to check the performance of different planetary boundary layer schemes within the meso-scale model WRF. The performance of the different models available in WRF are analyzed e.g. with regard to the atmospheric stability. This allows pointing out those conditions for which further improvements of the planetary boundary layer schemes are required. Measurements or additional simulations with the LES model PALM provide the data basis on which the planetary boundary layer schemes are further developed. In comparisons with data from the met mast FINO1 it turned out that especially the stable boundary layer is challenging for the planetary boundary layer schemes in WRF.

#### **Summary**

ForWind Oldenburg is involved in two of the LES model PALM has been used at ForWind to study the flow conditions in the ABL, the interaction between the atmospheric flow and wind energy converters, the flow conditions within as well as the flow conditions downstream of wind farms. The objective is to gain a deeper insight into these flows and to transfer the knowledge gained to improvements for fast, engineering wake models, the development of wind farm parameterizations for larger-scale models or simply better descriptions of turbulent processes in meso-scale models. In 2013, the wind turbine models implemented in PALM have been further improved. Comparisons with results from the engineering wake model highlighted the importance of a good description of the wind direction variability for an accurate simulation of wake effects. Intra wind farm wake effects need to be taken into account in accurate wind farm parameterizations for meso-scale models.

#### **References**

- [1] Raasch, S.; Schröter, M.: PALM- A large-eddy simulation model performing on massively parallel computers, *Meteorol. Z.* 10 (2001)
- [2] Lange, B.; Waldl, H.-P.; Gil Guerrero, A., Heinemann, D.; Barthelmie, R.J.: Modelling of Offshore Wind Turbine Wakes with the Wind Farm Program FLaP, *Wind Energy* 6 (2003)
- [3] Skamarock, W.C.; Klemp, J.B.; Dudhia, J.; Gill, D.O.; Barker, D.M.; Duda, M.G., Huang, X.Y., Powers, J.G.: A Description of the Advanced Research WRF Version 3, NCAR/TN-475+STR, Boulder, Colorado, USA (2008)

# Turbulence Test Facility for Artificially Wind Fields Generated by an Active Grid

Carl von Ossietzky Universität Oldenburg  
Institute of Physics, Research Group  
Turbulence, Wind Energy and Stochastics  
(TWiSt)

Nico Reinke, Agnieszka Hölling, Michael  
Hölling, Joachim Peinke

Funding: Ministry for Science and Culture  
in Lower Saxony (MWK)  
Ref.Nr. ZN2547

Duration: 12/2009 – 11/2014

## Introduction

Atmospheric turbulence and the basic understanding of the interaction of fluctuating wind fields with wind turbines becomes more and more important for wind energy related research. Of particular interest are wind field structures on large scales of the order of the swept area of the turbines as well as on small scales of the order of the chord length at different positions of the rotor blade. Acting and in particular changing loads resulting from transient aerodynamic forces are believed to be a major contributor to the unexpected high failure rates of modern wind turbines. In this context, wind tunnel experiments under laminar wind conditions provide only limited insight in unsteady aerodynamic effects. Therefore, ForWind Oldenburg is working on the further development of the active grid to generate adequate turbulent wind fields adapted for wind tunnel experiments on e.g. wind turbine models and airfoil profiles with and without active control devices.

## Project Description

The goal of this project was to build up a new wind tunnel, which copies the geometry of our existing acoustic wind tunnel in

terms of the nozzle shape and its outlet dimensions of  $1\text{ m} \times 0.8\text{ m}^2$ . The existing wind tunnel has a comparably small length of the test sections and measures about 1.8m in the open and about 2.6m in the closed configuration. The new wind tunnel was designed to increase the open as well as the closed test section to about 5m in length. This will allow investigating the evolution of generated turbulent wind fields further downstream of the outlet of the wind tunnel and the active grid, respectively. New protocols for the control of the active grid result in turbulent wind fields with different characteristics, which led to the name “turbulence test facility” for this wind tunnel. Approved control protocols that result in desired flow properties can subsequently be used also in the acoustic wind tunnel where additionally aerodynamic force and particle image velocimetry (PIV) measurements are possible.

## Turbulence test facility

It was planned to build up the new turbulence test facility in the laboratories of the TWiSt group at the University of Oldenburg, which automatically led to constraints in the dimensions and the orientation of this closed loop wind tunnel. Fig. 1 shows a technical drawing of the realized wind tunnel, where the active grid is sketched in red and the closed test section is sketched in green. The maximum length of the whole tunnel was limited to about 10m. Additionally, the closed loop has to be realized in an upright orientation so that the complete device was mounted over two levels on a metal skeleton in the laboratory. The diffuser as well as the guiding plates in the corners of the wind tunnel had to be manufactured with special opening angles and bending radii, respectively, in order to optimize the flow properties in the test section and minimize velocity gradients over the outlet of the nozzle [1].

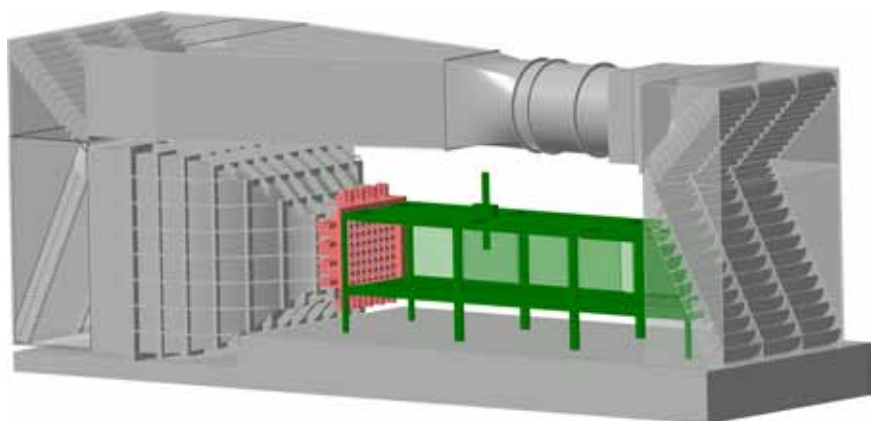

Figure 1: Technical drawing of new “turbulence test facility”. The active grid (red) as well as the closed test section (green) can be seen in the picture.

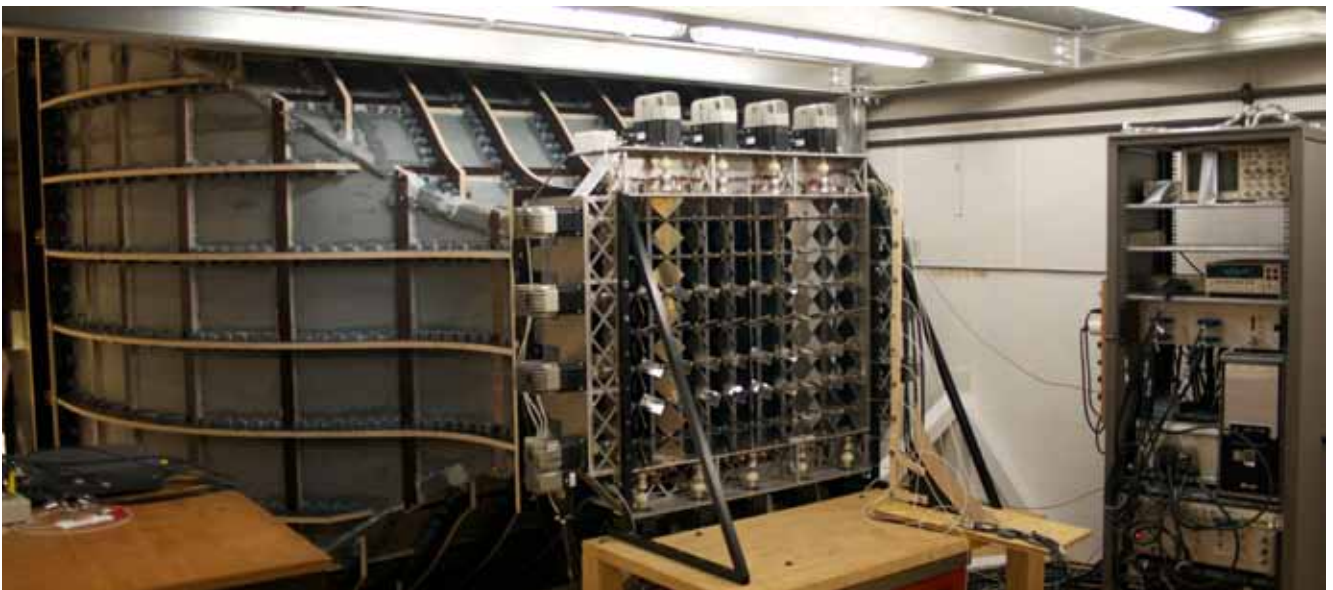

Figure 2: Picture of the jet nozzle outlet of the turbulence test facility with mounted active grid

Honeycombs and screens upstream of the nozzle assist in the flow preparation, which finally led to a homogeneous wind field with a turbulence intensity below 3% with only small scale structures left in the flow. It turned out that such flow conditions are sufficient for the intended use of the active grid in this turbulence test facility. In combination with a 15kW motor we are able to produce turbulent wind fields up to 20m/s. Fig. 2 shows a picture of the nozzle outlet of the turbulence test facility with the active grid mounted to it. Even this small detail of the whole construction backs up the fact that the given space of the existing metal skeleton was optimally used.

#### Adjusted turbulent wind fields for different types of experiments

Moving all axes of the active grid according to a predefined control protocol will result in turbulent wind fields, where either the statistics of the velocity increments on certain scales, the power spectrum of the absolute velocity or even the temporal evolution of the velocity can be set by the user within given limits. This results in a 3-dimensional turbulence that can be used to perform experiments on e.g. model wind turbines or anemometers under reproducible inflow conditions. For measurements with respect

to the dynamic behavior of 2D profile segments, it was found that by only addressing the vertical axes a quasi 2-dimensional flow can be generated. The goal here is to create atmospheric like flow properties that are highly correlated along the span of the profile. Such flow situations are used to investigate e.g. unsteady effects on airfoil profiles and can directly be compared with results from engineering models like the Blade Element Momentum (BEM) method. Stochastic analysis of the dynamics of the resulting aerodynamic forces are the basis for new models that take these unsteady effects into account.

#### Summary

The new turbulence test facility enables us to test and characterize new control protocols for the active grid in order to reproduce turbulent wind fields with desired 3D or quasi 2-dimensional flow properties for project related experiments in our acoustic wind tunnel. The development has advanced over the last years that the active grid already plays a fundamental role in many projects including experimental investigations on airfoil profiles (see also other reports). Additionally, the longer test

section allows investigating the evolution and the natural decay of artificially generated turbulence with increasing distance to the grid. This information can already be used to come up with strategies how to preserve turbulent flow properties over a very long test section, which will be one of the major topics once the big wind tunnel in the new research building (WindLab) will be up and running in fall 2016.

#### References

- [1] Barlow, B. J.; Rea, W., Pope, A.: Low-Speed Wind Tunnel Testing, 3rd Edition, John Wiley & Sons, 1999

# Parallel Computing Cluster for CFD and Wind Turbine Modeling

Carl von Ossietzky Universität Oldenburg  
Institute of Physics

Stefan Albensoeder, Wided Medjroubi,  
Björn Witha, Detlev Heinemann,  
Joachim Peinke, Gerald Steinfeld

Funding: Federal Ministry for Economic  
Affairs and Energy (BMWi)  
Ref.Nr. 0325220

Duration: 07/2010 – 12/2014

## Introduction

In wind energy research computational fluid dynamics (CFD) is an essential tool to improve blades and complete wind energy turbines, to better understand wake effects and the interaction of wakes in wind farms. Today's simulations resolve more details and enable the coupling of large and small scale effects. However, to perform these simulations, powerful computational resources are required.

For this purpose, the ForWind/Fraunhofer alliance has been supplied with an own High-Performance Computing (HPC)-facility called FLOW (Facility for Large-Scale Computations in Wind Energy Research). The HPC-cluster is designed for highly parallelized computations and contains more than 2200 cores with a high-performance interconnect and a large storage system.

In the scientific part of the project Large-Eddy Simulations (LES) with the software PALM are performed to investigate the interaction of the atmospheric boundary layer with the wakes of wind turbines. On smaller scales the computations of loads of wind turbines will be improved by simulations with the software OpenFOAM.

## Project Description

### HPC operation

The operational support of the HPC FLOW system and the user support are included in the project. This covers the installation and optimization of software as well as investigations in case of problems and introduction into HPC for users. Further tasks are the coordination between the IT-department and ForWind, and the extension of the HPC system by new or additional hardware.

### Wake simulations with the LES model PALM

A main task of the project is the further development of wind turbine parameterizations in the LES model PALM to simulate the interaction between the atmospheric boundary layer and wind turbine wakes.

Three turbine parameterizations have been implemented in PALM [1]. The simple and fast actuator disk model (ADM) represents the wind turbine as a permeable disk with uniformly distributed thrust forces across the whole disk. It does not consider the rotation of the blades. The actuator line model (ALM) uses the blade-element momentum (BEM) theory to calculate local forces along the blades represented as lines (see Fig. 1). Resolving the rotation of the blades requires a very small time step which makes the ALM computationally very expensive so that it is not feasible for the simulation of large wind farms. The enhanced actuator disk model with rotation (ADM-R) uses BEM theory like the ALM to calculate local forces at each point of the rotor disk but does not explicitly resolve the movement of the rotor blades. Thus it is much faster than the ALM. All three parameterizations include the tower and the nacelle.

As Fig. 2 shows, the ADM-R yields nearly identical results as the ALM, so that the computational cost can be greatly reduced for future wind farm simulations using the

ADM-R. The simple ADM cannot capture the shape and rotation of the near wake adequately but the results of the far wake are similar to the ADM-R and ALM results. Thus, for the simulation of large wind farms with large distances between the turbines it is justifiable to use the ADM. For investigations of the near wake and wind farms with closely spaced turbines, the ADM-R should be used.

The sensitivity of the parameterizations to the grid size has been studied and they are currently enhanced by turbine control features as yawing and variable rotational speed.

Another task of this project is to simulate large finite and infinite wind farms to determine the number of turbines that is required to achieve an asymptotic wake deficit. The sensitivity of the results to wind farm layout parameters such as the distance between the turbines and to meteorological parameters such as wind speed and stability will be investigated.

Further tasks are the simulation of wakes in an idealized complex terrain and the coupling of PALM with the mesoscale weather forecast model WRF to obtain realistic initial conditions.

### Simulation of the flow around wind turbine blades

Numerical simulations are conducted using the software package OpenFOAM [2] in order to investigate the aerodynamical characteristics of the flow over wind turbine blades. This investigation aims at a better understanding of the physical mechanisms underlying this type of flows. Very interesting and important results concerning the effect of the blade rotation on the aerodynamical coefficients are highlighted here.

The numerical results presented were obtained using URANS, and the MEXICO



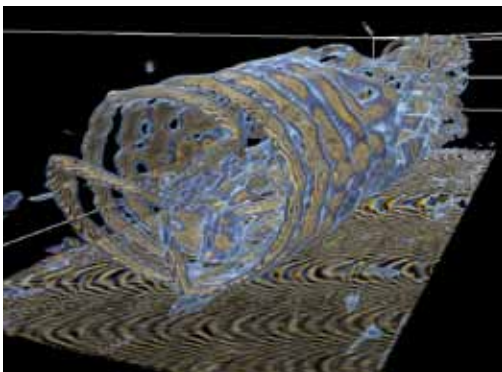

Figure 1.: LES of a wind turbine with ALM parameterization. Displayed are isosurfaces of the absolute vorticity which visualize tip and root vortices in the wake of the turbine.

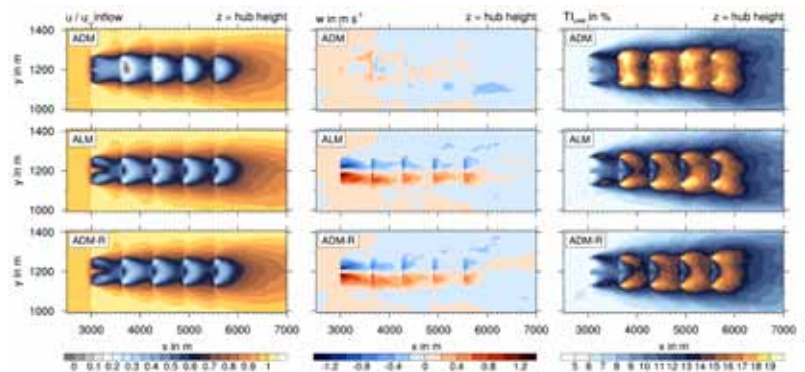

Figure 2: Comparison of the turbine parameterizations in PALM for a multiwake situation with 5 turbines in a row. Time-averaged horizontal cross-sections in hub height of the normalized horizontal velocity (left), vertical velocity (center) and turbulence intensity (right).

wind turbine was simulated [3]. A grid convergence study was performed to assess the suitability of the grids used.

When comparing the 2D polars to the 3D polars (both experimental and computational ones) it was found that the rotational effects are strong at the root section of the wind turbine blades. They influence the aerodynamical performance of the wind turbine strongly as lift is increased at the root sections. Further analysis shows that the phenomena of stall delay and lift enhancement can exist independently from each other. Concerning the drag coefficient, and contrary to what is often presented in the literature, the effects of the rotation on the drag are different in the case of the MEXICO turbine. Indeed, the drag is not increased by the rotational effects but remains almost unchanged, thus making any use of drag corrections unnecessary in this case. This finding implies that the effects of rotation are airfoil-type dependent as different findings were observed for other airfoil types in different publications.

Additionally, the flow field data obtained was compared qualitatively and quantitatively to PIV measurements obtained in the MEXICO experiment. In Fig. 3, the measured (upper figure) and computed (lower column) flow fields at 15 m/s inflow velocity are presented for the axial (left column) and radial wind speed (right column). The good agreement between the experiments and

the simulations is well presented on these figures. Furthermore, CFD simulations enable the visualization of the flow at regions where the PIV measurements are not possible (due to reflection of the laser sheet). These findings stress the lack of generality of the knowledge concerning rotational effects and the need for extensive research in this field using full rotor simulations.

the effect of meteorological parameters on wake flows. Additionally, the details of the flow around wind turbine blades was simulated with OpenFOAM and investigated in terms of aerodynamical characteristics. The results stress the lack of generality of the knowledge concerning rotational effects and the need for extensive research in this field using full rotor simulations.

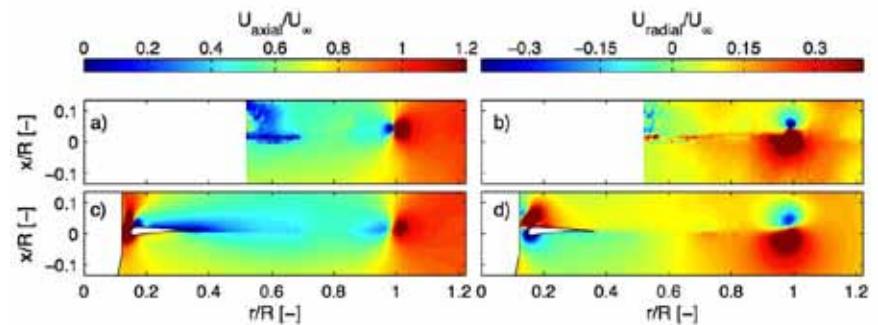

Figure 3: Computed (lower picture) and PIV (upper picture) of the normalized axial and radial velocities at 15m/s.

### Summary

Several wind energy projects benefit from the new HPC cluster that was installed as a part of this project. In the scientific part of the project, different wind turbine parameterizations in the LES model PALM have been enhanced and compared. They are used in this and other projects to investigate the flow in large, up to infinite wind farms, wake flow in complex terrain and

### References

- [1] Witha, B.; Steinfeld, G.; Heineemann, D.: Advanced turbine parameterizations in offshore LES wake simulations, Extended Abstract of the 6th International Symposium on Computational Wind Engineering (2014)
- [2] <http://www.mexnext.org/>
- [3] <http://www.openfoam.com/>

# Turbulence Test Facility for Artificially Wind Fields Generated by an Active Grid

Carl von Ossietzky Universität Oldenburg  
Institute of Physics, Research Group  
Turbulence, Wind Energy and Stochastics  
(TWiSt)

Pedro G. Lind, Matthias Wächter,  
Joachim Peinke

Universidade de Lisboa  
Centro de Física Teórica e Computacional  
Instituto para a Investigação  
Interdisciplinar

Teresa Scholz, Paulo Rocha,  
Pedro Lencastre, Vítor V. Lopes,  
Frank Raischel

Funding: FCT(Pt) - DAAD(De)  
Ref.Nr. 57036552 (DAAD), DRI/  
DAAD/1208/2013 (FCT)

Duration: 06/2013 – 05/2015

## Introduction

Wind energy is the most promising renewable energy source, but some key aspects remain poorly understood, such as turbulence, layering, and the statistics of extreme events. A better understanding of these phenomena can help to construct energy conversion schemes that are both more efficient and more robust.

Cascading, multi-scale behavior with turbulence-like characteristics and a pronounced stochastic aspect has also been observed in some financial markets [1]. One of the principal problems that lead to latest worldwide financial crisis was an over-reliance on stochastic models of risk beyond their scope of validity, and with an under-emphasis of rare, catastrophic events, a phenomenon described in the mathematical literature as the presence of fat-tail statistics [2].

This project aims at elucidating important features of cascading, turbulence-like processes that are underlying both wind energy conversion and the irrational, noisy and “volatile” behavior of many financial markets.

## Project Description

The project aims at understanding the stochastic aspects of complex systems, with particular emphasis on two types of empirical data, wind and financial data. In order to be able to construct accurate models for the physical properties of wind, accurate measurements of the wind velocity on the length scales of wind turbines at different locations in space are required, which often are subjected to rather strong measurement noise. The first goal of this project is to develop methods applicable for the analysis of measurements on both wind fields and wind turbines. Due to the complexity of the problem and the presence of different forms of measurement noise, a multi-dimensional implementation of the procedure is needed, which goes beyond the methods available by now.

The second goal is to extend this methodology to processes in scale, with special emphasis to financial data. This allows to derive the underlying evolution equation of a given financial index, composed of one deterministic contribution describing the inherent dynamics (drift rate) of the financial index, and another stochastic contribution characterizing its fluctuations. It has been found in the literature that the time series from financial markets typically show heavy tailed density distributions, which point to the presence of jump processes in the noise term, and an analysis of the increments in scale instead of time has been proposed. Present approaches, such as the famous Black-Scholes equation, correctly predict the central parts of these distributions, but

fail to account for the tails. The project aims at developing the stochastic models of risk further to include the statistics of rare occurrences, which have become popular under the name “black swan theory”, using their close analogy to turbulent physical systems [1].

## Summary

A great step towards the understanding of the stochastic aspects of complex systems has been the discovery that stochastic processes can be reconstructed from measurement data, which has recently found widespread application [3].

The co-evolution of two or more stochastic variables, such as wind speed and power production, can be described through a system of coupled stochastic equations, each one defined by a deterministic contribution (drift) and stochastic fluctuations from possible stochastic sources (diffusion). The coefficients of these so-called Langevin equations can be directly derived from observed or generated data through the estimation of conditional moments.

During the first six months of the project this methodology was applied to a data set generated by a Markov chain model [4] based on data from a wind turbine in Portugal. Using synthetic data sets that properly reproduce the statistical features of empirical data allows to use data sets as large as needed for the analysis. Moreover, the Markov chain model serves as a filter to remove periodicities. This is an essential step, as it would not be possible to correctly estimate the coefficients from the raw data.

Analysis of the drift and diffusion coefficients allowed to identify various distinct regions in the wind speed-power plane as well as the rated wind speed of the turbine [5].

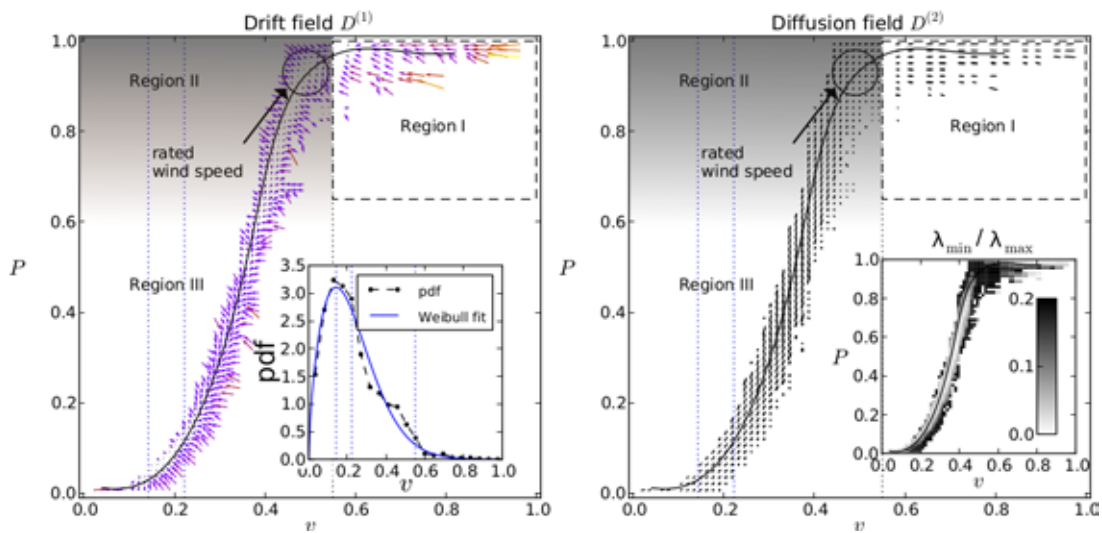

Figure 1: Drift (left) and diffusion (right) coefficients plotted in the wind speed-power plane. The diffusion ellipses are given by the two orthogonal eigenvectors of the diffusion matrix. The principal axes defining the ellipse are aligned along the eigenvectors with a length proportional to the corresponding eigenvalue.

For the next year it is planned to extend this methodology to time-dependent stochastic processes as well as to implement a method to extract the evolution equations in the presence of measurement noise.

Concerning financial data, there are two works in progress. The first one concerns the stochastic evolution of volume-price distribution using data from the New York stock market. The volume-price data appears to follow a specific statistical pattern, other than the evolution of prices measured in similar studies. Four bi-parametric models (Gamma, inverse Gamma, Weibull and log-normal distribution) are fitted to the volume-price distributions at each 10 minute samples. In a second step, the evolution of the distribution parameters is analyzed by means of coupled Langevin equations.

The second approach deals with the question if credit rankings are time-homogeneous and Markovian. For that an approach to test the reliability of homogeneous generators and the Markov property of stochastic processes is used on open access data provided by Moody's [6]. The analysis is based on a comparison between empirical transition matrices aggregated over fixed time windows and candidate transition matrices generated from measurements taken over shorter periods.



Figure 2: First meeting of the bi-national project group at the ForWind center in September 2013.

#### References

- [1] Ghashghaie, S.;Breyman, W.; Peinke, J.; Talkner, P.; Dodge, Y.: Turbulent cascades in foreign exchange markets, *Nature* 381, 767-770, 1996.
- [2] R.N.Mantegna and H.E. Stanley, Scaling behaviour in the dynamics of an economic index, *Nature* 376, pp. 46-49, 1995.
- [3] Friedrich, R.; Peinke, J.; Sahimi, M.; Tabar, M.R.R.: Approaching complexity by stochastic methods: From biological systems to turbulence, *Physics Reports*, 506, p. 87, 2011.
- [4] Lopes, V.V.; Scholz, T.; Estanqueiro, A.; Novais, A.Q.: On the use of Markov chain models for the analysis of wind power time series, *Environment and Electrical Engineering (EEEIC)*, 2012 11th International Conference on, pp. 770-775, 2012.
- [5] Raischel, F.; Scholz, T.; Lopes, V.V.; Lind, P.G.: Uncovering wind turbine properties through two-dimensional stochastic modeling of wind dynamics, *Phys.Rev.E*, 88, 042146, 2013.
- [6] www.moody.com

# A Toolbox for Offshore Wind Farm Cluster Design

Carl von Ossietzky Universität Oldenburg  
Energy Meteorology Group

Sonja Drüke, Robert Günther,  
Detlev Heinemann, Michael Schmidt,  
Gerald Steinfeld

Funding: EU  
Ref.Nr. FP7-Energy-2011 283145 / Cluster-  
Design

Duration: 12/2011 – 05/2016

## Introduction

Since 2011 a consortium consisting of 3E, ECN, Imperial College, RWE Innogy, Senvion and the Energy Meteorology Group of ForWind has been working on the project ClusterDesign [1]. The main objective is the development of a toolbox for an integrated design of offshore wind farm clusters.

The toolbox will serve project developers to select cluster layouts that are favorable with regard to energy yield, cabling costs and load mitigation. For optimization of the operation of wind farm clusters a controller that allows for operating the cluster as a virtual power plant will also be implemented into the toolbox.

In order to support the achievement of project goals, the project is based on four main elements:

1. **Modelling:** Models dealing with certain aspects that are of relevance when a cluster of wind farms is planned, namely ambient atmospheric conditions, wake losses, mechanical loads, cabling costs, power system support and wind farm control are further developed.
2. **Integration:** The aforementioned models are integrated into a single toolbox al-

lowing for an integrated wind farm cluster design.

3. **Validation:** The single models as well as the toolbox as a whole will be validated against measured data obtained from a measurement campaign in a large offshore wind farm cluster. Based on the comparisons with measurements the models will be further developed. The validation of the toolbox will also comprise tests of the cluster control strategy.
4. **Valorisation:** In the end, the tool box developed in the project should become an industrially applicable solution.

## Project Description

The main contribution of the Energy Meteorology Group to the project is in work package (WP) 1 “Advanced Flow Modelling”.

In order to provide the toolbox with information on ambient atmospheric conditions required as input by power or wake models, ForWind will derive a wind and stability atlas (WASA) for the North Sea region. The WASA will be based on twenty years of simulations with the meso-scale model WRF. Furthermore, the work of ForWind in WP1 comprises the further development and validation of ForWind’s in-house engineering wake model FLAP as well as the definition of interfaces between the WASA and the wake models of the toolbox. Another contribution by ForWind is the development of an innovative wake modelling tool that couples an advanced flow model, the large-eddy simulation (LES) model PALM with the aeroelastic code FLEX. This work is done in cooperation with the wind turbine manufacturer Senvion.

In the reporting period, the preparatory work for the generation of the WASA could almost be finished. Different setups of the WRF model have been tested in order to reach a good agreement between simulat-

ed and measured data. Particularly, WRF runs varying in the choice of the planetary boundary layer (PBL) scheme have been carried out. The evaluation of the performance of the different model runs which simulated the atmospheric conditions over the North Sea in the year 2007 was based on data from the FINO1 met mast that had been thoroughly processed for that purpose. Fig. 1 and 2 show results from the preparatory WRF simulations. As can be seen the choice of the Mellor-Yamada-Nakanishi-Nino (MYNN) scheme results in the lowest wind speed bias and the best agreement in the stability distribution when compared with FINO1 data. Based on the results of the preparatory study it was decided to use the MYNN scheme for the production runs for the WASA. The format of the WASA has been defined during the reporting period. The atlas will be a NetCDF file that provides information on how often a combination of a certain wind speed, wind direction, turbulence intensity, stability and air density occurs at a defined height within twenty years.

The further development of the wake model FLAP comprised i.a. the revision of the superposition of single wakes as well as adding an output of the horizontal shear. First results show that using the horizontal shear from FLAP as input in a load model leads still to conservative load estimates, but the predicted loads are smaller than those obtained with input from the standard Frandsen model. As a first test of the wake models of ForWind (FLAP) and ECN (FarmFlow) that will be part of the ClusterDesign toolbox, detailed comparisons between the results of these models with data from the offshore wind farm alpha ventus have been carried out. Moreover, for this benchmark case the results of the models of ForWind and ECN have been compared with those of state-of-the-art wake models widely used in wind energy industry, such as WindPRO or Windfarmer. It turned out that the accuracy of the Ainslie solver in FLAP as well

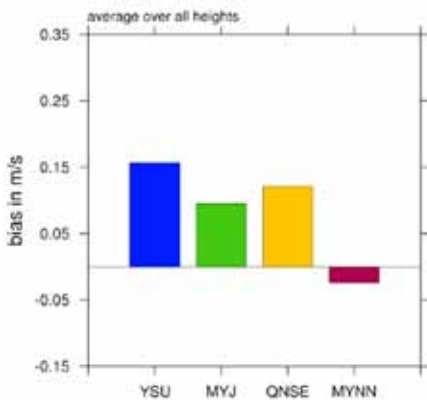

Figure 1: Wind speed bias of WRF simulations using different PBL schemes when compared with FINO1 data for the year 2007

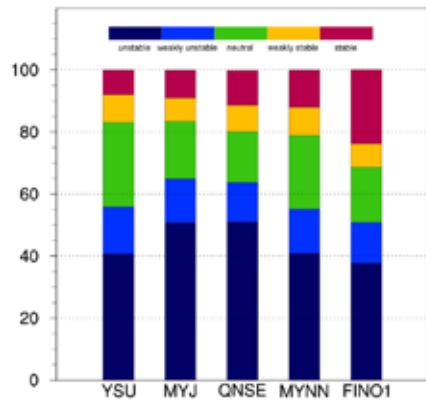

Figure 2: Distributions of the stability parameter 1/L derived from the WRF simulations using different PBL schemes as well as from data measured at FINO1

as FarmFlow was competitive with that of commercially available tools. For the whole wind farm alpha ventus the prediction error of the Ainslie solver in FLAP was smaller than 1% of the actually measured power output (see Fig. 3).

Two different approaches have been realized for the coupling between the LES model PALM and the aeroelastic code FLEX. The first approach is a two-way interaction in that PALM provides information on the flow field in the rotor layer to FLEX. Next, FLEX carries out one time step and gives

information on the new position of the rotor segments as well as the forces acting on each rotor segment back to PALM. The second approach is a one-way coupling. Here, the impact of the rotor on the flow in PALM is parameterized by an advanced actuator disk approach. The wind field in the rotor layer is output with a frequency of several Hz, converted into the WND-file format and in a subsequent run used as input by the aeroelastic model. During the reporting period both approaches could be implemented. Currently, both approaches are intensively tested.

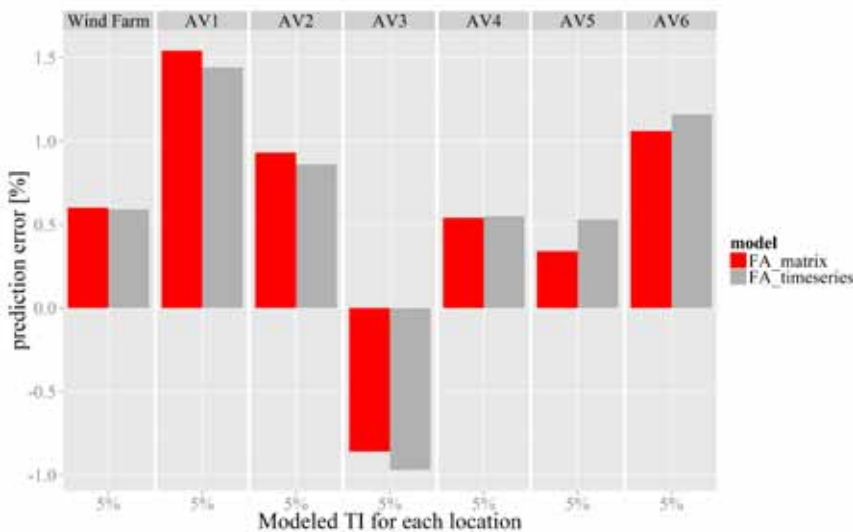

Figure 3: Prediction error of the Ainslie solver in FLAP for single wind turbines as well as for the whole wind farm alpha ventus

## Summary

The goal of the EU-FP7 project Cluster Design is to develop a toolbox consisting of models each of them dealing with a different aspect that has to be taken into account when a wind farm cluster and its operation modes are designed. The tool will support wind farm developers to optimize energy yields and to reduce offshore wind energy production costs.

The objective of WP 1 led by ForWind is to further advance the modeling of flow conditions around and within wind farms which is an important input parameter for energy yield and load calculations. Preparatory work for the generation of a WASA based on WRF simulations could be finished during the reporting period. A benchmark showed that the engineering wake model developed by ForWind delivered results with an accuracy that is comparable to that of commercial state-of-the-art wake models.

## References

- [1] [www.cluster-design.eu](http://www.cluster-design.eu)

# Turbulence Resolving Simulations for Meteorological Assessment of Wind Energy Sites in Complex Terrain

Leibniz Universität Hannover  
Institute of Meteorology and  
Climatology, PALM research group

Lennart Böske, Christoph Knigge,  
Björn Maronga, Siegfried Raasch,  
Matthias Sühling

Funding: Federal Ministry for Economic  
Affairs and Energy (BMWi)

Ref.Nr. 0325719C

Duration: 11/2014 – 10/2017

## Introduction

The project is part of a larger joint research project coordinated by the Wobben Research & Development GmbH, a subsidiary of the German wind turbine manufacturer ENERCON. The main goal is to further develop new high resolution simulation techniques from basic and academic research in order to apply them for load and power forecasts of wind turbines in complex terrain. The turbulent wind field is simulated with the large-eddy simulation (LES) technique, where the large, main energy containing eddies are explicitly resolved by the numerical grid, while only the small scale turbulence is parameterized. The numerical solver will be tested in an industrial environment for real complex terrains, including vegetation and steep topologies, and will be validated with field measurements from existing wind turbine sites. One major goal is to demonstrate the applicability of the simulation tool in an industrial environment.

## Project Description

Wind energy sites in complex terrain are often exposed to very turbulent atmospheric flow fields which generate heavy mechanical loads on the rotor blades. The rapidly changing loads may significantly reduce lifetime of the systems. Current simulation techniques used for site assessment studies (Reynolds-Averaged Navier-Stokes models, RANS) only predict the mean flow features and can not account for turbulent fluctuations. Therefore, the project aims to apply an LES model for simulating the turbulent atmospheric boundary layer flow above complex terrain with very high spatial resolution down to a few meters. The high resolution data will be used by project partners from the University of Stuttgart (Institut für Aerodynamik und Gasdynamik, IAG) and the DLR Braunschweig (Institut für Aerodynamik und Strömungstechnik) as input to engineering CFD models which calculate the near field flow around the blades in order to determine mechanical loads.

Because of its high computational demands, the LES technique has been used mainly for basic research in the past, but the rapidly increasing power of computer systems nowadays allow to use it also for applied industrial applications. The PARallelized LES Model PALM [1] is the central tool for simulating the atmospheric turbulence in this project. It has been developed at IMUK (Institute of Meteorology and Climatology), has a very high computational performance and is highly optimized to be used on massively parallel computer architectures. Such computer clusters are meanwhile operated even by medium-sized companies, demonstrating that LES has or will become an option e.g. for site assessment studies.

The PALM code is also used by other For-Wind partners, mainly at the University of Oldenburg (Institute of Physics, Research Group Energy Meteorology).

The project is in its initial phase, where model results for simple idealized topographies (e.g. Gaussian hills) are compared and validated with wind tunnel data. Final simulations will be carried out for existing sites with very complex topography like shown in Fig. 1 and compared with field measurement data. One main project goal is to demonstrate that LES can be applied operationally for site assessment studies. Therefore, sensitivity studies will be done in order to determine optimum values, e.g. for the computational domain size and grid spacing, that minimize the computational demands of the simulations but guarantee sufficient accuracy of the results.

## Summary

The project aims to demonstrate that turbulence resolving simulations of atmospheric flows are ready to be used for operational site assessment studies in complex terrain. High resolution simulations will be carried out with the LES model PALM for existing sites and compared with field observations.



Figure 1: Wind energy site in complex terrain (Source: Courtesy of ENERCON, Germany)

#### References

- [1] Maronga, B., Gryschka, M., Heinze, R., Hoffmann, Kanani-Sühring, F., Keck, M., Ketelsen, K., Letzel, M. O., Sühring, M., Raasch, S. (2015): The Parallelized Large-Eddy Simulation Model (PALM) version 4.0 for Atmospheric and Oceanic Flows: Model Formulation, Recent Developments, and Future Perspectives, *Geosci. Model Dev.*, 8, 2515-2551, DOI: 10.5194/gmd-8-2515-2015

# Analysis of the Shadowing Effects and Wake Turbulence Characteristics of Large Offshore Wind Farms by Comparison of »alpha ventus« and »Riffgat« (GW Wakes)

Carl von Ossietzky Universität Oldenburg,  
Institute of Physics, Wind Energy Systems  
(project coordination), Turbulence,  
Wind Energy and Stochastics,  
Energy Meteorology, Marine Physics

David Bastine, Detlev Heinemann,  
Martin Kühn, Joachim Peinke,  
Rainer Reuter, Jörg Schneemann,  
Gerald Steinfeld, Elisabeth Stütz,  
Davide Trabucchi, Juan José Trujillo,  
Stephan Voß, Matthias Wächter

Partners (Part B): Fraunhofer IWES

Funding: Federal Ministry for Economic  
Affairs and Energy (BMWi)  
Ref.Nr. 0325397A

Duration: 08/2011 – 05/2015

## Introduction

The flow conditions in very large offshore wind farms with hundreds of multi-mega-watt wind turbines sited in wind farm clusters differ in various aspects significantly from what is presently known on wake effects of small to medium-scale wind farms. Moreover specific turbulence characteristics will result from superposition of many individual wakes and their interaction with the marine atmospheric boundary layer.

The research objectives of the project "GW Wakes" include the reduction of energy yield and operating risks of large offshore wind farms. This will be achieved by verifying the interaction of the turbulent maritime boundary layer with very large wind farms and the characterization of the turbulent wake conditions of individual wind turbines and the entire park. The project is

supporting the economical design of wind turbines and new large offshore wind farms. The focus of the project lies on the studies of the flow situation of multiple overlapped wind turbine wakes in large offshore wind farms and on the wake of the whole wind farm itself.

GW Wakes aims to understand these complex flow situations better and to develop computational models that can be used for an optimized planning of large offshore wind farms in the future. For this goal innovative laser remote sensing wind speed

measurements (lidar) were performed in »alpha ventus« and will be performed in »Riffgat«, two offshore wind farms installed in the North Sea. The detailed wind fields, obtained with this measurement technique, will be applied in the validation of micro-scale as well as meso-scale wind farm models developed in the project.

## Project Description

The main activities included in "GW Wakes" are as following:



Figure 1: One of ForWind's long range scanning Lidars Windcube 2005 located on the offshore research platform Fino1 scanning the flow around a wind turbine in the nearby offshore wind farm »alpha ventus«.



### Work package 1: Measuring technique

To measure the flow within and around the offshore wind farms, a so called multi-lidar system is used. It consists of two or three scanning long-range lidar units that are synchronized and controlled remotely. The units were placed in the first measurement campaign in »alpha ventus« on the substation and on the research platform »Fino1« aiming at the same volume of the atmosphere from different directions (see Fig. 1).

The measurement campaign in »alpha ventus« started in July 2013 and was successfully finished in March 2014. During the eight month many different measurement scenarios have been performed with the three Lidar units, depending on the scientific purpose, the wind directions and atmospheric conditions. Fig. 2 shows the wind field behind an operating wind turbine of »alpha ventus« measured with the multi-Lidar system. The colour indicates the wind speed and the black arrows the wind direction. The drop of wind speed behind the turbine is clearly visible and also the changes in wind direction in the wake. The 2D wind field has been derived from the radial wind speeds measured by two Lidar devices and averaged over 10 minutes.

The second campaign is planned in a significantly larger wind farm with a focus on several overlapping wakes and the interaction of the whole wind farm with the atmospheric environments. The start of this campaign is planned for spring 2015.

### Work package 2: Turbulence characterization

The measurements performed in the offshore wind farms will be stored in a large database suitable also for studies of turbulence. In this respect the project foresees the validation of state of the art models used to estimate turbulence properties such as turbulence intensity, integral length scale, turbulence spectra and non-Gaussian turbulence effects (intermittency) at different positions in the wind farm. Additionally, the data is planned to be used to validate engineering models simulating stationary as well as dynamic wake effects.

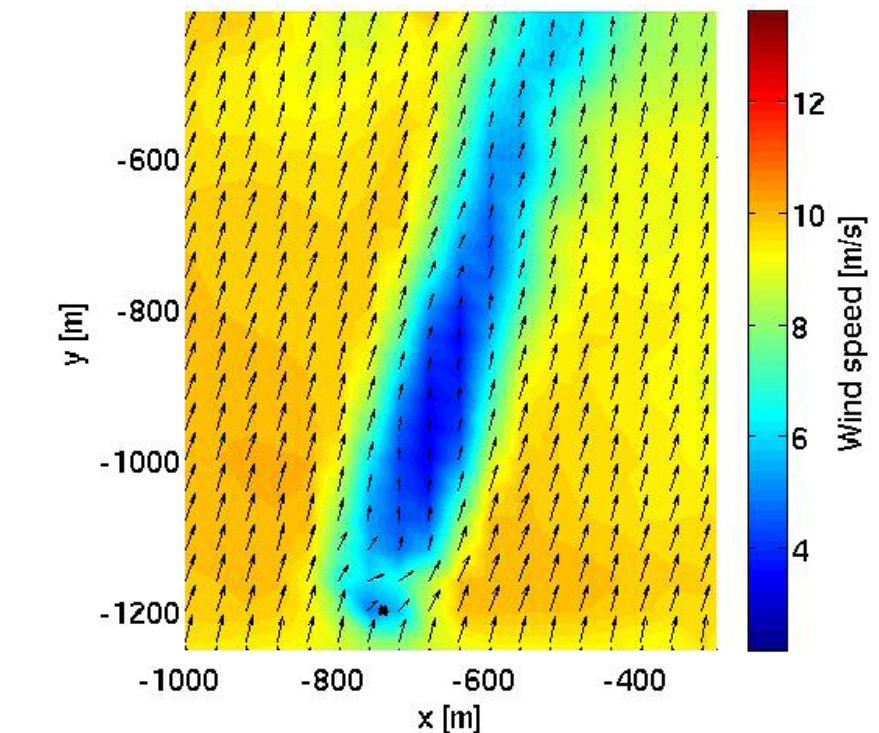

Figure 2: Visualization of the 2D wind field around a wind turbine measured with two scanning long range Lidars in »alpha ventus«. The reduced wind speed in the wake deficit is clearly visible.

### Work package 3: Modeling and validation of meteorological flow situations

The wind farms »alpha ventus« and »Riffgat« are being modeled with flow models at different scales. The different flow conditions are simulated with a Large-Eddy-Simulation (LES) code which is capable of the interaction of the turbulent marine boundary layer with the different wind turbines. The results of the simulations will be validated with the multi-lidar measurements delivered by the experimental campaign.

Furthermore, meso-scale meteorological simulations of the region including »Riffgat« and of cluster effects in the North Sea will be performed and compared with lidar data as well.

### Work package 4: Technology transfer

In cooperation with Fraunhofer IWES the results achieved in the other work packages will be used to enhance wind farm mode-

ling software. This should improve the accuracy in the evaluation of loads acting on WTs operating in multiple wake conditions and to include the influence of neighboring wind farms on the energy production estimation.

### Summary

Multi-lidar technology is developed to investigate the flow conditions around and within large offshore wind farms. Two offshore experimental campaigns are performed to deliver a unique set of high quality data suitable for validation of theoretical models of turbulence and wakes. These include wind field simulations generated with LES or meteorological meso-scale codes. The outcome of the research activities is to be included in industrial wind farm modeling software. This will improve the overall accuracy of the energy yield estimation for large wind farms at industrial level.

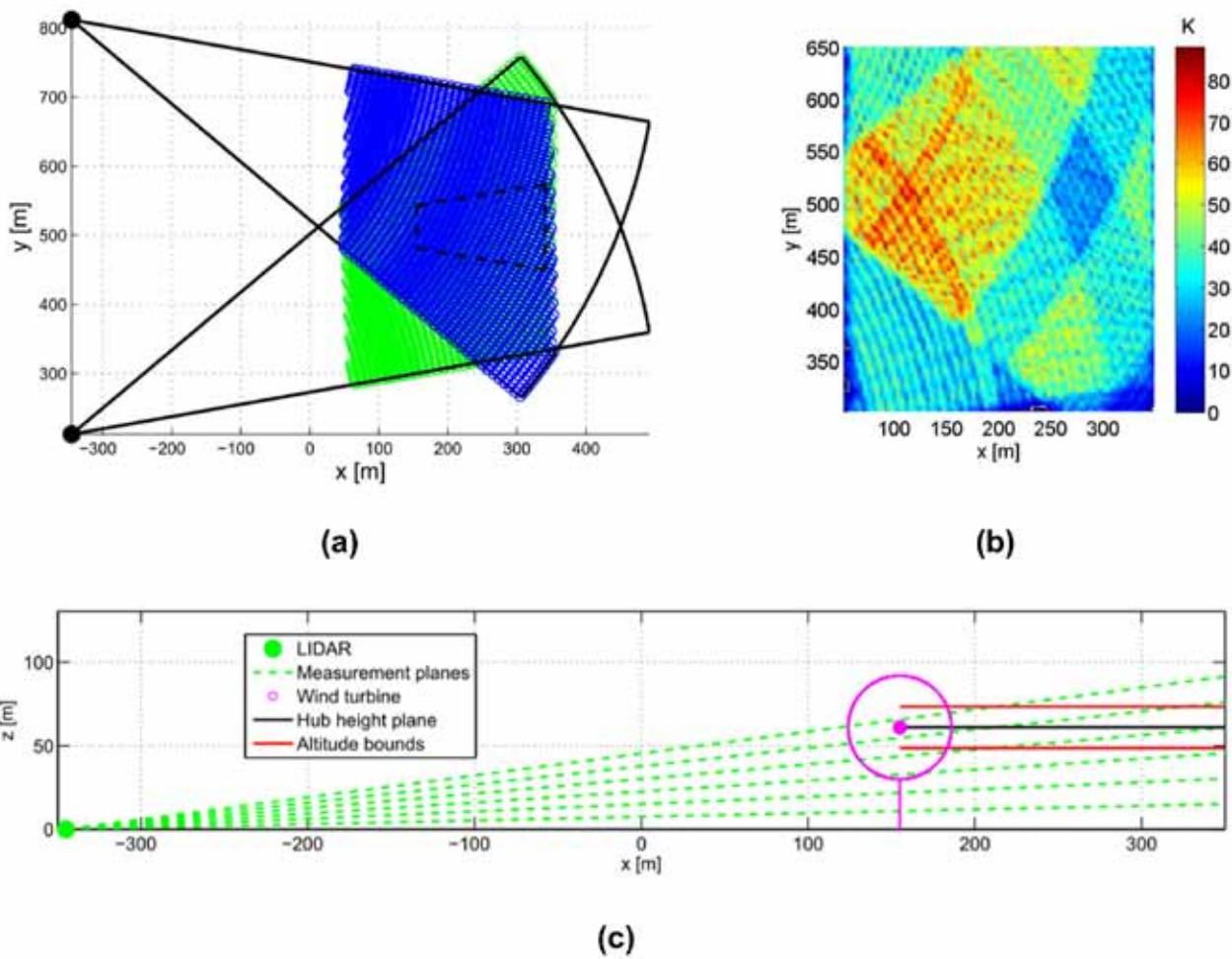

Figure 3: Schematic view of simulated Lidar measurements in a LES generated wind field. Each blue and green point corresponds to a simulated Lidar measurement point. (a) View from above and (c) side view of the simulation setup. In (b) the number  $K$  of Lidar measurement points, available per grid point is shown.

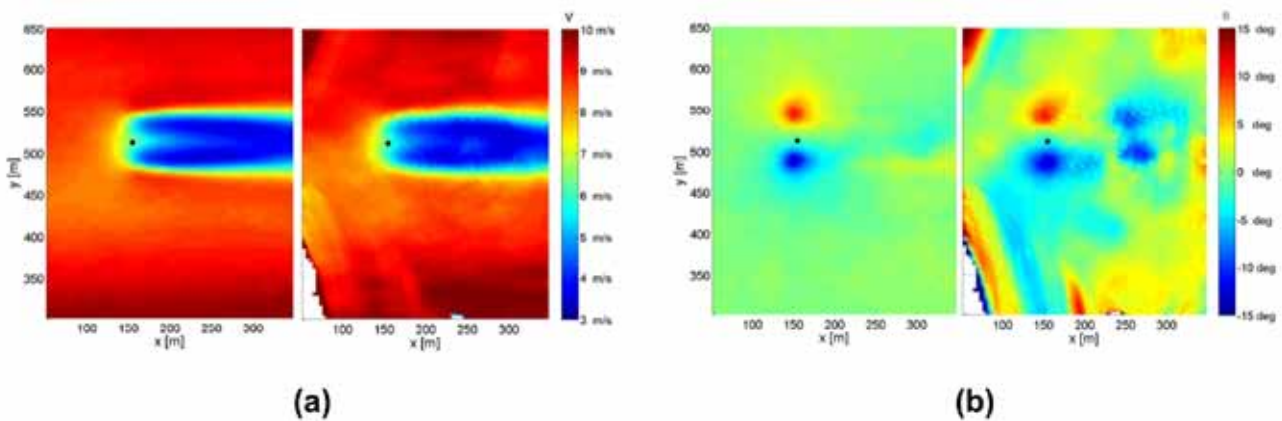

Figure 4: Amplitude (a) and wind direction (b) of the horizontal wind velocity directly visualized from the LES wind field (left figures) and derived from the results of the simulated Lidar measurements (right figures). The wind turbine position is given by the black dot. The deviations in wind direction between the LES field and the simulation results are caused by low data availability of the Lidar simulation at certain areas of the field (see Figure 3b).

#### References

- M. van Dooren, M.; Beck, H.; Rott, A.; Trujillo, J. J.; M. Kühn, M.: Wake effect measurements in »alpha ventus« with long-range LiDAR windscanners, FVWE Jahreskolloquium 2014 Proceedings, January 2015 (submitted / under review)
- Trabucchi, D.; Trujillo J.J.; Schneemann J.; Bitter, M.; Kühn, M.: Application of staring lidars to study the dynamics of wind turbine wakes, Meteorologische Zeitschrift, 2014
- H. Beck, H.; D. Trabucchi, D.; M. Bitter, M.; Kühn, M.: The Ainslie wake model - An update for multi megawatt turbines based on state-of-the-art wake scanning techniques, EWEA 2014, Barcelona, 2014

# EERA-DTOC

## European Energy Research Alliance – Design Tools for Offshore Wind Farm Cluster

Carl von Ossietzky Universität Oldenburg,  
Institute of Physics

Hauke Beck, Juan-José Trujillo,  
Matthias Wächter, Martin Kühn

Funding: European Commission –  
Seventh Framework Programme (FP7)  
Ref.Nr.: 282797

Duration: 01/2012 – 06/2015

In partnership with:  
Technical University of Denmark - DTU  
Wind Energy (Coordination),  
ForWind-Wind Energy Systems,  
ForWind-Turbulence, Wind Energy and  
Stochastics,  
European Wind Energy Association  
(EWEA),  
Fraunhofer Institute for Wind Energy and  
Energy System Technology,  
Fundacion CENER-CIEMAT,  
Energy Research Centre of the  
Netherlands,  
SINTEF Energi AS,  
Centre for Renewable Energy Sources and  
Saving,  
Centro de Investigaciones  
Energeticas, Medioambientales y  
Tecnologicas, Universidade de Porto,  
University of Strathclyde,  
The Trustees of Indiana University,  
Collecte Localisation Satellites SA,  
Statkraft Development AS,  
Iberdrola SA,  
Statoil Petroleum AS,  
Overspeed GmbH & Co. KG,  
Bard Engineering GmbH,  
HEXICON AB,  
The Carbon Trust,  
E.ON Sverige AB,  
Renewable Energy Systems Limited

### Introduction

With the large amount of offshore wind farms to be built in the next years, clusters of wind farms will appear gradually at favourable locations, like in the German Bight and Dogger Bank. Additionally, arrays of floating wind farms planned near long-distance grid cables independent of water depth also expected to appear in the future. The planning and design of these clusters pose new challenges with regards to the siting of the connected wind farms, the design of the interconnecting grid structure and the integration of the large amount of power into the electricity supply systems. The installation of offshore wind farm clusters means that large installed capacities will be erected in a relatively small area. This will lead to a large variability of the power output and to large forecast errors in comparison to current installations on land. The variability in the power output depends on the variability of wind speed and direction. Wind speed variability directly leads to power variations, while wind direction variability will lead to power variations because of the influence of wake effects, which are very sensitive to wind direction changes. These characteristics of clusters pose challenges to system stability and require a large amount of reserve power. However, in large clusters wind speed and direction variations will not be seen by all wind farms at the same time. This leads to a smoothing of the power output compared to the behaviour of single wind farms. At the same time, the error of a wind power forecast will decrease due to the smoothing effect.

### Project Description

The EERA-DTOC project members including industry partners have proposed an integrated and validated design tool combining the state-of-the-art wake, yield and electrical models available in the consortium, as a plug-in architecture with possibility for third party models to extend and enhance predictions. In order to decrease uncertainties around wind farm wake predictions, a measurement campaign together with the new data available from the industry partners enabled enhanced tuning of the far-field of wind farm wakes. The design tool will be tested and demonstrated by the industry partners using their own data and test cases, and the experience incorporated into the model architecture.

During the project, all participants aim at progress beyond the state-of-the-art in the field of farm wake modelling. The better wake models will provide higher confidence in the energy yield predictions. While this project will be managed to tune the existing models to the values found by the measurement campaign, the data set will in the future enable further development of the farm wake models, which in turn will find their way into future iterations of the design tool. A new approach is to integrate the effect of wind farms in the meso-scale models themselves. However, the major step forward is going to be the tool itself. Currently, most of the models are employed sequentially by the developers of offshore wind farms, and optimization of all parameters is quite difficult and involves a lot of pasting data back and forth. With this integrated tool, optimization of different parameters will be possible from within a single software package, and the design of entire clusters of wind farms as wind power plants will for the first time be possible in one go.

## Contribution of ForWind

Within the scope of the ongoing German research project GigaWatt-Wakes (GW-Wakes), the research group Wind Energy Systems of ForWind performed a comprehensive measurement campaign in the 60 MW research offshore wind farm »alpha ventus«. The measurements carried out include long-range lidar inflow and wake measurements with high temporal and spatial resolution as well as high altitude wind profiling. For this purpose a setup of three long-range lidar devices equipped with flexible scanner heads (multi-lidar) operated synchronously from three platforms within the wind farm in addition to the scope of the GW-Wakes project.

In the first year of work, the researchers at ForWind have been working together with the wind farm modellers to select appropriate scan strategies and the main wind characteristics to be measured. Four measurement campaigns have been performed from August 2013 till January 2014. The first campaign involved the measurement of a single remote meteorological mast in front of the wind farm for free inflow from southwest. Furthermore, the measurement strategy was designed to allow a comparison of the multi-lidar and ship-lidar measurements free flow conditions. The second, third and fourth campaigns were dedicated to meas-

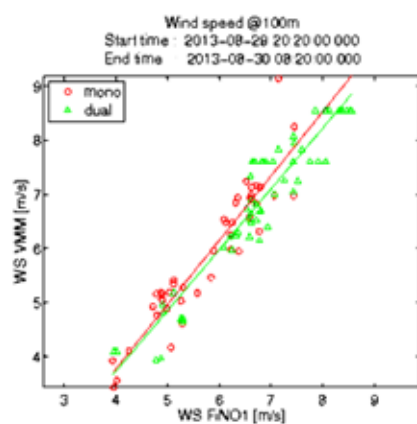

Figure 1.: Comparison of wind speed measurements in the inflow of »alpha ventus« between scanning lidar and FINO1 met mast. Single lidar (red), Dual-lidar (green)

ure inflow and wake quasi-simultaneously. The core of these measurements was the sequential measurement of a dual remote meteorological mast at different positions in front and behind the wind farm.

In addition, Fraunhofer IWES carried out a measurement campaign with ship based lidar measurements at available distances from near to far downwind in the wake of »alpha ventus«. The multi-lidar is able to measure the near wake of the wind farm with high detail and more flexibility. In this respect, the ship based measurements complement the lidar measurements by providing data for the far wake of the wind farm. ForWind and Fraunhofer IWES have been evaluating the possibility of performing synchronous measurements at »alpha ventus« in the framework of EERA-DTOC.

The research group Turbulence, Wind Energy and Stochastics of ForWind has contributed as well with stochastic methods to the work package "Power curve uncertainty evaluation". Furthermore, in a benchmarking case study the annual energy production of a fictitious wind farm was evaluated under defined conditions and the results were compared among the project partners.

## Summary

The European Energy Research Alliance – Design Tools for Offshore wind farm Clusters (EERA DTOC) is partly funded by the European Commission. The EERA-DTOC project combines expertise to develop a multidisciplinary integrated software tool for an optimized design of offshore wind farms and clusters of wind farms.

The proposed design tool combines several models available in the EERA consortium and is based on open interfaces. This enables future integration of other software. In order to decrease uncertainties around wind farm wake predictions, a measurement campaign together with the new data available from the industry partners enabled enhanced tuning of the farfield of wind farm wakes. The design tool will be tested by the industry partners using their own data and

test cases, and the experience incorporated into the model architecture. The project participants aim at progress beyond the state-of-the-art in the field of farm wake modelling. The better wake models will provide higher confidence in the energy yield predictions.

The ForWind research group Wind Energy Systems performs a comprehensive measurement campaign in the 60 MW research offshore wind farm »alpha ventus«. The measurements include long-range lidar inflow and wake measurements with high temporal and spatial resolution as well as high altitude wind profiling. The ForWind research group Turbulence, Wind Energy and Stochastics contributes with stochastic methods to the work package "Power curve uncertainty evaluation".

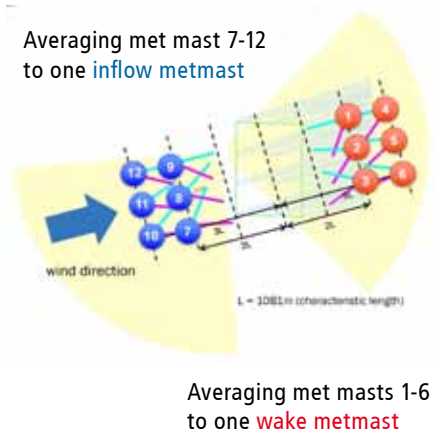

Figure 2: Setup of 6 virtual lidar met masts each in the inflow and the wake of »alpha ventus«

## References

<http://www.eera-dtoc.eu>

# Energy-Weather Forecasting and Analysis (E-Ways)

Carl von Ossietzky Universität Oldenburg,  
Institute for Physics, Wind Energy  
Meteorology

Lueder von Bremen, Constantin Junk,  
Stephan Späth, Alexander Kies,  
Nicole Stoffels, Anna Mehrens,  
Frederik Haack,  
Francisco Santos Alamillos

Funding: Ministry for Sciences and Educa-  
tion of the Federal State of Lower Saxony  
Ref.No.: ZN2547

Duration: 12/2009 – 11/2015

## Introduction

The research team “Energy-Weather Forecasting and Analysis (E-Ways)” investigates meteorological aspects how to integrate increasing shares of wind power into the power supply system. Deterministic wind power forecasts are easy-to-understand and single-valued for each forecast horizon and grid box. While, ensemble forecasts allow the estimation of the forecast uncertainty from which probabilities of future outcomes can be derived. Balancing analyses of European wind power feed-in is carried out using long-term reanalysis data.

## Project Description

### Wind and wind power ensemble forecasts

Nowadays, many weather centers such as the European Centre for Medium-Range Weather Forecasts (ECMWF) and the German Weather Service (DWD) provide ensemble forecasts. However, raw ensemble forecasts have deterministic biases and ensemble spread deficits. To remove those, various calibration methods for wind ensemble forecasts have been proposed in the last years.

We have systematically compared state-of-the-science post-processing methods for the calibration of wind ensemble forecasts and have identified site-dependent forecast improvements over the uncalibrated ensemble forecasts at four onshore and three offshore meteorological towers in central Europe [1]. We have shown that ensemble model output statistics (EMOS) [2] and a bivariate recursive and adaptive wind vector calibration (AUV) [3] outperform other calibration methods such as bivariate EMOS (UVE-MOS) and EMOS with Ensemble Copula Coupling (ECCEMOS) in terms of deterministic and probabilistic scores. Highest improvements in forecast skill are found for high-roughness and complex topography sites. The reason is the coarse resolution of the ECMWF model, which leads to larger forecast biases and spread deficits of the uncalibrated ensemble at these sites (Fig. 1).

The calibrated ensemble wind forecasts are then transformed into power using appropriate power curves. The disadvantage of the calibration of wind ensembles and subsequent power transformation is the additional error introduced in the power curve model. However, analog-based methods developed for wind power forecasting [4] do not require a power curve. The analog ensemble (AnEn) approach generates probabilistic information from a purely deterministic forecast, rather than being a calibration technique of an existing ensemble. A key aspect of the AnEn algorithm is the search of analogs, which is based on a multivariate metric that estimates the degree of analogy between the current deterministic prediction and past forecasts from a historical data set (Fig. 2).

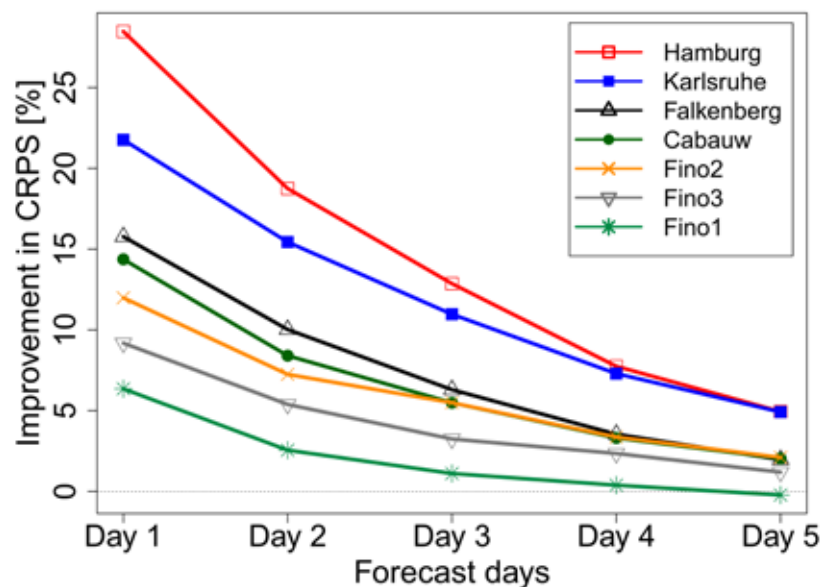

Figure 1: Improvement in CRPS for AUV calibrated ensemble wind speeds over the raw ensemble for seven met masts at 100 m height (Jan 2011-Dec 2012)

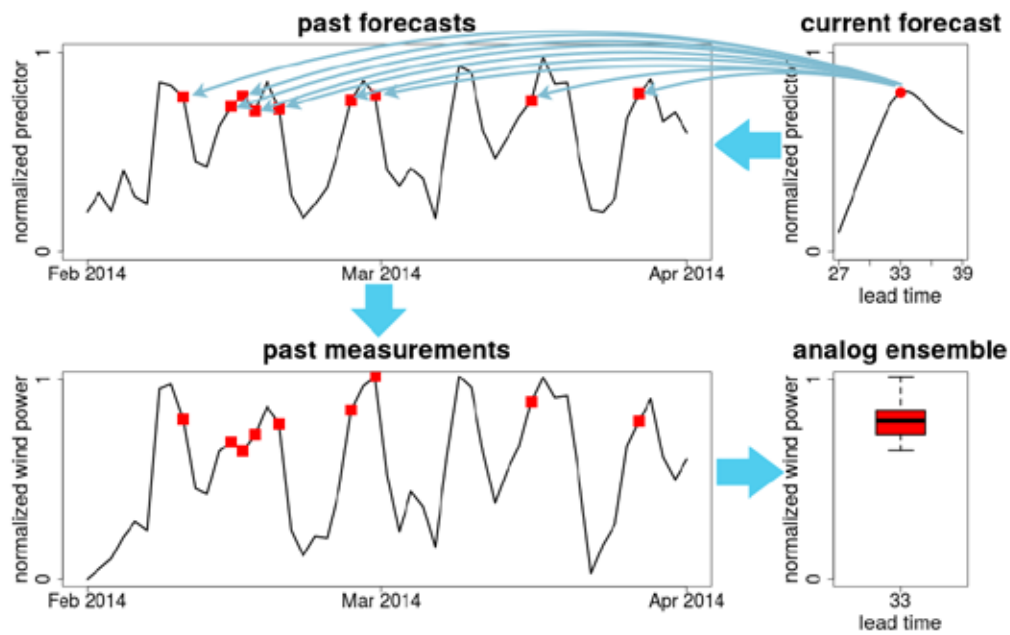

Figure 2: Sketch of the functioning of the analog ensemble method. See text for more detail.

A detailed study was started out to select the best predictors (e.g., wind speed and direction at several heights in the atmospheric boundary layer, geopotential height, mean sea level pressure and temperature) when searching for analogs.

In May 2012, a new 20 member ensemble called COSMO-DE EPS was implemented operationally at the German Meteorological Service (DWD) with lead times up to +21h. It was found that EMOS calibration is superior to AUV calibration (Fig. 3). This can be attributed to the generation of the ensemble as the members of COSMO-DE EPS are per design distinguishable. Always five members are initialized and forced with the same global model (GFS, IFS, GME and GSM). The ECMWF Ensemble uses singular vectors and an ensemble of data assimilations which leads to indistinguishable members. The rank histogram of the raw COSMO-DE-EPS (Fig. 3a) resembles the correlation and clustering of always five members. The AUV calibration (Fig. 3c) maintains the correlation between members while EMOS calibrated members (Fig. 3b) populate the ranks rather uniformly and can be regarded as reliable.

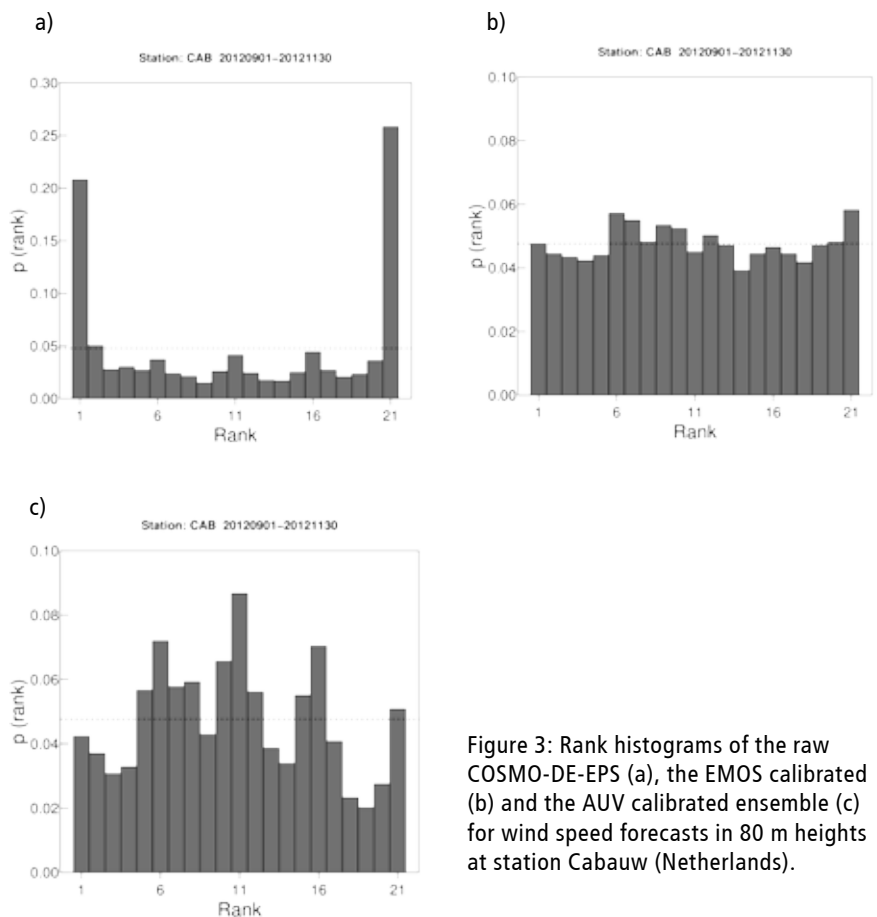

Figure 3: Rank histograms of the raw COSMO-DE-EPS (a), the EMOS calibrated (b) and the AUV calibrated ensemble (c) for wind speed forecasts in 80 m heights at station Cabauw (Netherlands).

**Simulation and analysis of wind power**

Future European power supply studies require the simulation of feed-in of weather dependent renewable sources assuming that future weather years will be equivalent to the past. Therefore output of mesoscale atmospheric models, e.g. horizontal wind speed, is used to simulate wind power at each grid point. Very long time series of the MERRA (Modern-Era Retrospective Analyses for Research and Applications) reanalysis is available in hourly resolution from 1979 onwards with 1/2 degrees latitude  $\times$  2/3 degrees longitude resolution at 10 and 50 m height. Utilizing COSMO-EU wind speed analyses a statistical downscaling of MERRA has been done. Before applying standard power curves (e.g. Enercon E-126) winds are logarithmically extrapolated to hub height. For many applications the wind power feed-in is aggregated to the country level. The distribution of simulated European wind power for 10 different years is shown in Fig. 4. In case of European wide wind power smoothing (dashed lines), the peak of the distributions moves to the right while the right tail is reduced. Thus, wind power variability is reduced in an interconnected European power supply system compared to individual countries.

It was found that the PBL parameterization in COSMO (here COSMO-DE) has deficits in simulating the diurnal cycle of atmospheric stratification in heights relevant for wind energy. The verification is carried out against measurements at the Cabauw met mast. The results indicate that the modeled unstable stratification (negative gradient of potential temperature), is slightly overestimated. However, stable stratification (right side of the plot) is strongly underestimated. The model is in most cases not able to simulate gradients of more than 3 K between 35 m and 2 m, while measured values range up to 7 K (Fig. 5).

Mesoscale wind fluctuations with a time scale of minutes to hours cause extremely relevant wind fluctuations, e.g. at large offshore wind farms. In order to predict those mesoscale wind fluctuations it is required to understand the relevant atmospheric processes and conditions. Weather

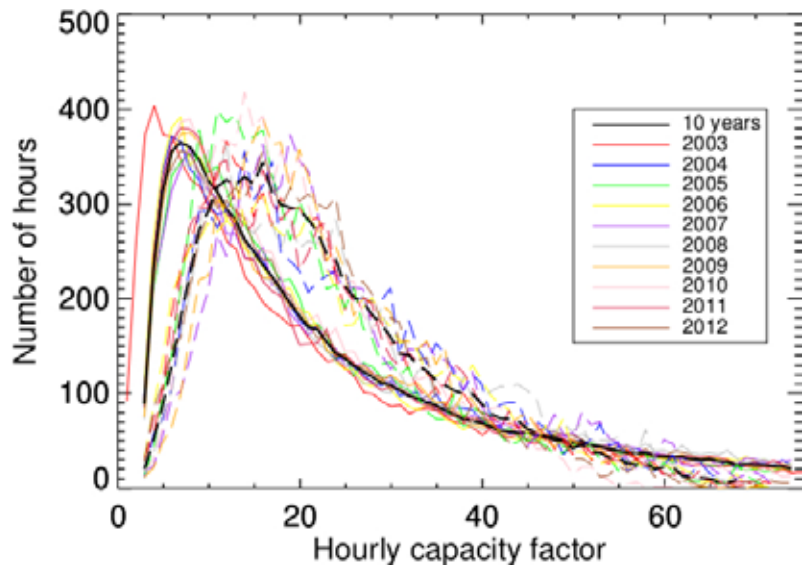

Figure 4: Yearly distribution function of hourly capacity factors for Europe (full smoothing on the copperplate) (dashed) and without smoothing effects (solid) computed for 140 m hub height using an Enercon E-126 power curve.

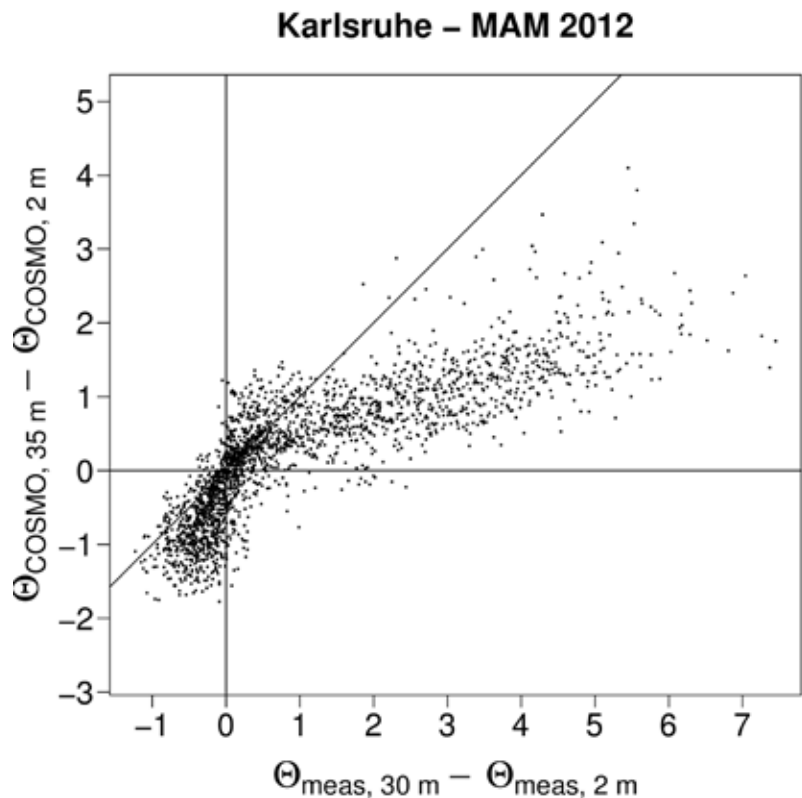

Figure 5: Simulated potential temperature gradient in the COSMO-DE analysis versus the measured potential temperature gradient at Cabauw for spring 2012.



observations, wind field measurements and simulations of an offshore site with a size of several kilometers are analyzed to characterize the heterogeneous wind fields and to develop an easy and robust measure for spatial and temporal wind fluctuations. It is the goal to formulate a relationship between the spatial and the temporal scale with respect to wind fluctuations.

## Summary

Various calibration approaches have been implemented to improve the skill of ensemble wind forecasts up to 25 %. Further studies will demonstrate the use of ensemble calibration for wind power forecasts. Long-term wind power time series have been modeled for Europe using an efficient statistical downscaling approach. The analysis of European balancing of PV and wind power will answer future questions of required transmission, storage and backup capacities.

## References

- [1] Junk, C.; von Bremen, L.; Kühn, M.; Späth, S.; Heinemann, D. (2014): Comparison of post-processing methods for the calibration of 100 m wind ensemble forecasts at off- and onshore sites, *J. Appl. Meteorol. Climatol.*, 53, pp. 950-969.
- [2] Thorarindottir, T.; Gneiting, T. (2010): Probabilistic forecasts of wind speed: ensemble model output statistics by using heteroscedastic censored regression, *Journal of the Royal Statistical Society: Series A(Statistics in Society)*, 173, pp. 371-388
- [3] Pinson, P. (2012): Adaptive calibration of (u, v)-wind ensemble forecasts, *Q. J. Roy. Meteor. Soc., Wiley*, 138, pp. 1273-1284.
- [4] Delle Monache, L.; Eckel, F. A.; Rife, D. L.; Nagarajan, B.; Searight, K. (2013): Probabilistic Weather Prediction with an Analog Ensemble, *Mon. Wea. Rev.*, 141, pp. 3498-3516

# IEA Wind Annex 32 – Wind Lidar Systems for Wind Energy Deployment

Carl von Ossietzky Universität Oldenburg  
Institute of Physics, Wind Energy System

Martin Kühn, Davide Trabucchi

Funding: IEA Wind  
Ref.Nr. Annex 32

Duration: 05/2012 – 05/2015

## Introduction

The International Energy Agency (IEA) Wind Implementing Agreement [1] is a vehicle for member countries and organizations to exchange information on the planning and execution of national projects on further implementation of wind energy. Another objective is to undertake co-operative research and development (R&D) projects called tasks or annexes. The contracting parties to this agreement are designated by the 22 Member Countries, the European Commission, the Chinese Wind Energy Association, and the European Wind Energy Association. The IEA Wind Agreement sponsors cooperative research tasks and provides a forum for international discussion of research and development issues. In general only the coordinating activities of IEA Wind tasks are funded by contributions collected from the participants while each participant bears its own cost for its work contribution.

In spring 2011 ForWind – University of Oldenburg proposed together with the Danish Technical University (DTU) Wind Energy and Stuttgart Wind Energy (SWE) to start a new project intended to disseminate the state of the art knowledge concerning the application of lidars for wind energy. The same year in autumn, the Executive Committee of IEA Wind (ExCo) officially approved the proposal and start the 32nd IEA Wind Task "Wind lidar systems for

wind energy deployment". The project was officially kicked off in May 2012 and its first phase is going to be concluded in summer 2015. All interested organizations in the participating countries are invited to join the task. Currently 52 institutions from 15 countries are involved in the activity of the task (see Table 1).

## Project Description

The aim of Annex 32 is to address the very fast development of wind lidar technologies and their applicability for more accurate measurement of wind characteristics relevant for a more reliable deployment of wind energy power systems [2]. The purpose is to bring together the present actors in the industry and research community to create synergies in the many R&D activities already on-going in this very promising and new remote sensing based measurement technology. Task 32 is only considering lidar systems even though sodar is another promising remote sensing technique were covered by previous IEA Wind Topical Expert Meetings.

The main objective of Annex 32 is the publication of experimentally tested recommended practices and expert reports for wind lidar measurements based on the joint experience of the participants. The recommendations will be benchmarked with measured data collected at various meteorological and lidar operational conditions.

The work plan is organized in three scientific subtasks and smaller work packages (Table 2) as follows:

- Subtask 1: Lidar calibration and classification
- Subtask 2: Lidar procedure for site assessment
- Subtask 3: Lidar procedure for turbine assessment

While ForWind – University of Oldenburg is acting as operating agent, the coordination of the subtasks is delegated to DTU – Wind Energy, NREL and SWE – University of Stuttgart.

Subtask 1 is dedicated to coordinate efforts concerning the accuracy of wind lidars, in particular for installation on flat terrain, wind turbine nacelle and floating stations. Extensive work has been successfully completed to explain the reduced repeatability of the calibration of the same lidar during the same experimental installation. The results are going to be documented in an expert report and will provide a useful tool to reduce the uncertainty budget of ground-based lidar measurements.

Valuable progress has been achieved also towards a routinely use of nacelle based and floating lidar systems. For the former of these two advanced applications, a procedure was suggested by DTU Wind Energy. The interested participants have been invited to apply this procedure and give feedback. Concerning the latter one, the preparation of a recommended practices (RP) on floating lidars will be finished mid 2015.

Subtask 2 gathers the activities regarding the proper application of lidar measurements for site assessment. Common quantities as wind speed and turbulence intensity are differently evaluated by conventional anemometers and lidar vertical profilers. In fact, the former systems returns an "in situ" wind speed, the latter ones sample a volume at several positions to evaluate it. For this reason, lidar vertical profilers present some issues in inhomogeneous wind fields. Besides, the described volume sampling of the lidars affects the accuracy of the turbulence assessment, even when the homogeneity of the flow is given. The scope the subtask is to give a better understanding about these issues and reduce the refrain of some users from the adoption of lidar systems.

Table 1:  
Countries  
Participating in  
Task 32

	Country	Institution(s)
1	Canada	AXYS, Technocenter Eolien
2	China	Beijing New Energy Technology Co., China Renewable Energy Engineering Institute, CWEA, Goldwind, Science & Technology Co. Ltd.
3	Denmark	DONG Energy, DTU Wind Energy, (Windar)
4	Germany	AREVA Wind GmbH, Deutsche WindGuard, DEWI, ForWind – Oldenburg, Fraunhofer IWES, DNV-GL, SWE – University of Stuttgart, GWU, Senvion SE
5	Japan	ITOCHU Techno-Solutions Corp., Mitsubishi Electric Corp., (Mie University)
6	Norway	Christian Michelsen Research, Meventus, NORCOWE, University of Bergen
7	UK	Carbon Trust, Frazer Nash, NEL; RES, Sgurr Energy, SSE, Zephyr, Natural Power, Offshore Renewable Energy Catapult LiDAR
8	US	AWS TrueWind, University of Colorado, Cornell University, NCAR, NOAA – ESRL, National Renewable Energy Laboratory, Pacific Northwest National Laboratory
	Participants in progress	
9	Austria	Energiewerkstatt
10	Belgium	3E
11	Switzerland	Meteotest
12	France	Epsiline, Leosphere, Avent Lidar, IFP Energies nouvelles
13	Israel	Pentalum
14	Netherlands	ECN
15	Sweden	Windvector

Table 2:  
Organization of the  
content in Task 32

<b>IEA Wind Task 32 – Wind lidar systems for wind energy deployment</b> Operating Agent: M. Kühn, D. Trabucchi (ForWind)		
<b>SUBTASK I:</b> Calibration & classification of lidar devices M. Courtney (DTU)	<b>SUBTASK II:</b> Procedures for site assessment A. Clifton (NREL)	<b>SUBTASK II:</b> Procedures for site assessment A. Clifton (NREL)
1.1 Ground based lidar calibration (includes former 1.2)	2.1 RP 15. Ground-based vertically profiling remote sensing for wind resource assessment	3.1 Exchange of experience in power performance testing acc. to 61400-12-1
1.3 Calibrating nacelle lidar	2.2 Wind field reconstruction methods in complex flow with wind lidars (includes former 1.2)	3.2 Wind field reconstruction from nacelle based lidar measurements
1.5 Calibrating floating lidar	2.3 Measurement of Wind Characteristics	3.3 Nacelle-based power performance testing
	2.4 Recommended practices on the use of floating lidar systems	3.4 Load estimation using a lidar system (on hold)

Some work in this direction was already completed under IEA Wind - Task 11 with the publication in 2013 of RP: 15. Ground-Based Vertically-Profiling Remote Sensing for Wind Resource Assessment [3]. Participants of Subtask 2 contributed to its publication by reviewing the document. Moreover, a preparatory phase for an extension of RP 15 to the application of lidars in inhomogeneous flows has been initiated and a state of the art document which classifies the so-called lidar “use cases” by their goal, methodology and field of application is almost completed. Within this document, particular attention is given to lidar vertical profilers in complex terrain and to scanning lidars.

The scope of this subtask includes also the better understanding of the application of lidar vertical profiler for turbulence measurements and for the evaluation of the annual energy yield based on lidar measurements. An extensive bibliography about the first topic has been collected and reviewed by the participants. Concerning the second one, a technical report has been written on hori-

zontal and vertical extrapolation from vertical profiler possibly in combination with meteorological mast anemometry for wind resource assessment.

Subtask 3 focuses on the integration of wind lidar in the standard procedures for the assessment of wind turbines. Its activity is divided in nacelle- and ground-based topics and includes power performance issues too. Additionally, possible methods for wind field reconstruction from nacelle-based lidar data are going to be reviewed and disseminated.

In the last two years participants dealt mainly with the application of IEC61400-12-1 ed. 2 CD for power performance of wind turbines by means of ground-based remote sensing [4]. Valuable results were achieved which will provide a significant contribute to future revision of this standard.

Moreover, a blind test was carried out among five participants to compare different wind field reconstruction algorithms

applied to nacelle-mounted lidar in flat terrain. The deviation of the results from the reference ultra-sonic anemometer is in the range 0.2-0.99 m/s. Further discussion will follow to extend the models, for instance to complex terrain applications.

## Summary

Under IEA Wind Annex 32 the efforts of more than 50 international institutes are coordinated to achieve a better confidence in the employment of lidar system for wind energy application. Within the three main subtasks the state of the art knowledge about the relevant issues concerning wind lidar measurement has been collected and prepared to be included in the expert reports and recommended practices expected as result of the project. Preparations for a second project phase lasting other three years are currently undertaken.



## References

- [1] [www.ieawind.org](http://www.ieawind.org)
- [2] [www.forwind.de/IEAAnnex32](http://www.forwind.de/IEAAnnex32)
- [3] Clifton, A., Elliott, D., Courtney, M.: Recommended Practice 15. Ground-Based Vertically-Profiling Remote Sensing for Wind Resource Assessment, IEA Wind, ([www.ieawind.org](http://www.ieawind.org), 2013)

# WindScanner.eu – The European WindScanner Facility (Preparatory Phase Project)

Carl von Ossietzky Universität Oldenburg,  
Institute of Physics

Stephan Barth, Martin Bitter,  
Martin Kühn, Stephan Voss

Funding: European Commission (FP7)  
Ref.Nr. 312372

Duration: 10/2012 – 09/2015

## Introduction

The planned "European WindScanner Facility" (WindScanner.eu) will provide a distributed research infrastructure, consisting of advanced remote sensing devices for mainly wind energy applications. Included in the European Strategy Forum on Research Infrastructures (ESFRI) in 2011, the "WindScanner Facility" will be able to provide new knowledge about detailed three-dimensional atmospheric wind flows, leading in this way to an increased development of more efficient, smarter and lighter wind turbines. It shall be established as a pan-European research infrastructure open for researchers and users from other disciplines. The objective of the running preparatory phase is to establish the technical, financial and administrative framework for the research infrastructure, whose operation is proposed to start in 2016.

## Project Description

Besides the establishment of the WindScanner research facility the preparatory phase will coordinate, integrate and upgrade already existing modern Lidar remote sensing devices at wind energy test centers in Europe. By this the European competitive advantage in wind energy system research and development will be enhanced.

During the preparatory phase the network between WindScanner research demonstration nodes and partners of the European Energy Research Alliances (EERA) is developed involving several European partners from different countries, namely the coordinator DTU Wind Energy (Denmark), CENER (Spain), CRES (Greece), ECN (Netherlands), ForWind – University of Oldenburg (Germany), Fraunhofer IWES (Germany), IPU (Denmark), LNEG (Portugal), SINTEF (Norway) and University of Porto (Portugal). All these partners contribute in the work packages of the preparatory phase. ForWind – University of Oldenburg participates in the work packages "Organization & Finance", "Legal Issues", "Technology & Innovation", "Nodal Coordination" and "Open Access".

One of the major tasks deals with the provision of mobile remote sensing devices and highly skilled staff to perform joint measurement campaigns. Thus, the preparatory phase includes personal trainings, exchange programs and first campaigns within the WindScanner research infrastructure. The main objective of the new facility is to become a center of excellence formed by leading European research organizations.

One of the first measurement campaigns was conducted in summer 2014. During this campaign six long-range scanning Lidar, provided by DTU and ForWind-University of Oldenburg performed fully synchronized wind field scans at a 200 m meteorological met mast near Kassel, Germany, operated by Fraunhofer IWES as host of the campaign. The six scanning long-range Lidar were deployed around the met mast and were controlled by a master / client software and a data connection between each Lidar device.

This first measurement campaign, performed by several project partners within the WindScanner research infrastructure

demonstrated the feasibility of pan-European measurement campaigns and was the first remote operation of six synchronized scanning long-range Lidar units. Furthermore, the experiences made during this campaign are helpful for the definition of procedures for the following campaigns within WindScanner.eu.

## Summary

In November 2010 the preparatory phase started to establish the required technical, financial and administrative structures for the WindScanner research facility. The actual start of this European infrastructure is planned for 2016. The research facility WindScanner.eu will consist of remote sensing measurement equipment and concepts for measurements performed with remote sensing devices such as Lidar during pan-European measurement campaigns. The application of three-dimensional measurements with synchronized scanning Lidar opens new possibilities by the WindScanner Facility. The obtained results will lead to a better understanding of the wind field, improved computer models on multiple scale wind energy applications and allow the optimization of wind turbines and wind farm designs.

## References

[www.windscanner.eu](http://www.windscanner.eu)

# Development of Nacelle-Based Lidar Technology for Performance Measurement and Control of Wind Energy Converters

Carl von Ossietzky Universität Oldenburg,  
Institute of Physics

Paul Gerke Hofmeister, Martin Kühn,  
Martin Kunze, Rainer Reuter, Matthias  
Wächter

Funding: Federal Ministry for Economic  
Affairs and Energy (BMWi)  
Ref.Nr. 0325216A

Duration: 11/2010 – 01/2015

## Introduction

For future multi-megawatt wind energy converters (WEC) in large-scale offshore wind farms new and advanced control strategies are required. Dynamic wind loads have to be reduced efficiently and with minimal controller operation, in order to de-

liver electricity to the grid in an optimized way. Already small deviations from normal operation have to be detected using new instruments – namely lidar – and adapted control strategies.

From these general considerations, the following main research topics of the RAVE-LIDAR II project have been developed:

- How can a robust and cost-efficient nacelle-based lidar system be demonstrated for power performance measurement and control of wind turbines?
- How can the power performance of wind turbines inside wind farms be assessed and monitored using nacelle-based lidar wind measurements?
- How can nacelle-based wind measurements be utilised for predictive turbine control facilitating gust compensation and optimization of energy yield?

## Project Description

Up to now the implementation of these visions suffers from fundamental obstacles, despite the progress in many fields of wind energy technology. Large uncertainties due to the complex inflow within the rotor area influence the control and operation of wind energy converters. This problem becomes even more serious with growing rotor diameters beyond 120 m. Current control concepts can only react to wind field fluctuations which have already caused changes in rotational speed or loads. When evaluating the averaged or instantaneous power production, it is unclear from which exact wind conditions they have been obtained. Thus, a precise performance analysis is impossible.

The current project LIDAR II focuses on the following topics, which are considered crucial for the vision of a future "intelligent offshore wind turbine":



Figure 1: Front (left) and rear (right) view of Whirlwind 1. The dimensions are approximately 500 x 450 x 450 mm<sup>3</sup>.



Figure 2: Experimental integration of Whirlwind 1 into the spinner of an AREVA Multibrid M5000 wind turbine, November 2013.

1. Prototype of a robust and cost-efficient lidar for nacelle-mounted application on WEC, which is suitable for industrialisation.
2. Methods to determine the power performance of a WEC using a nacelle-based lidar for inhomogeneous inflow in wind farms, which are common operating conditions in contrast to the idealized conditions according to IEC 61400-12-1.
3. Procedures for monitoring the Langevin power characteristic using the robust lidar.
4. Control strategies for optimization of power performance and reduction of loads, using nacelle-based lidar measurements.

These components shall be developed and tested with the help of diagnostic equipment which is already installed in the offshore test field »alpha ventus«.

In 2013, the work at ForWind – University of Oldenburg focused on the first topic, namely the development of a robust and

cost-efficient wind lidar for integration into current and future wind energy converters. After the definition of the measurement principle and the important design parameters in 2011-12, substantial progress was achieved also in the development of hard- and software. Whirlwind 1 - the new robust lidar – has been realised in 2013 as a prototype. Based on test applications the electronic and optical components as well as the firmware and operating software have been further improved and optimised by end of year 2014. Tests of the instrumental performance in comparison with other wind lidars have been achieved at the university campus in Stuttgart and Oldenburg, as well as offshore in the »alpha ventus« wind farm. The project ended by January 2015.

The design of the instrument is compact and ruggedized, meeting high requirements for operation in harsh environments such as integration into the rotating spinner of a wind turbine. This configuration results directly in a scanning operation, thus avoiding the use of a dedicated scanner or other

moving mechanical parts. Wind vector data are measured remotely over distances of 60 to 400 m, depending on atmospheric visibility conditions. The measuring range of wind speeds is up to 80 m/s with a 0.1 m/s resolution. Based on ruggedized embedded technology the instrument provides reliable long-term measurements of wind profiles to identify already small deviations from normal operation and to adapted control strategies for wind energy converter operation.

### Summary

The project RAVE-LIDAR II continues the successful work of the completed LIDAR project and aims at results which can directly be utilised for the development of cost-efficient large-scale wind energy converters. The offshore test field »alpha ventus« serves as an ideal testing opportunity for lidar development as well as for new control and monitoring strategies. The co-operation with turbine manufacturers ensures the relevance for future industrial utilisation.

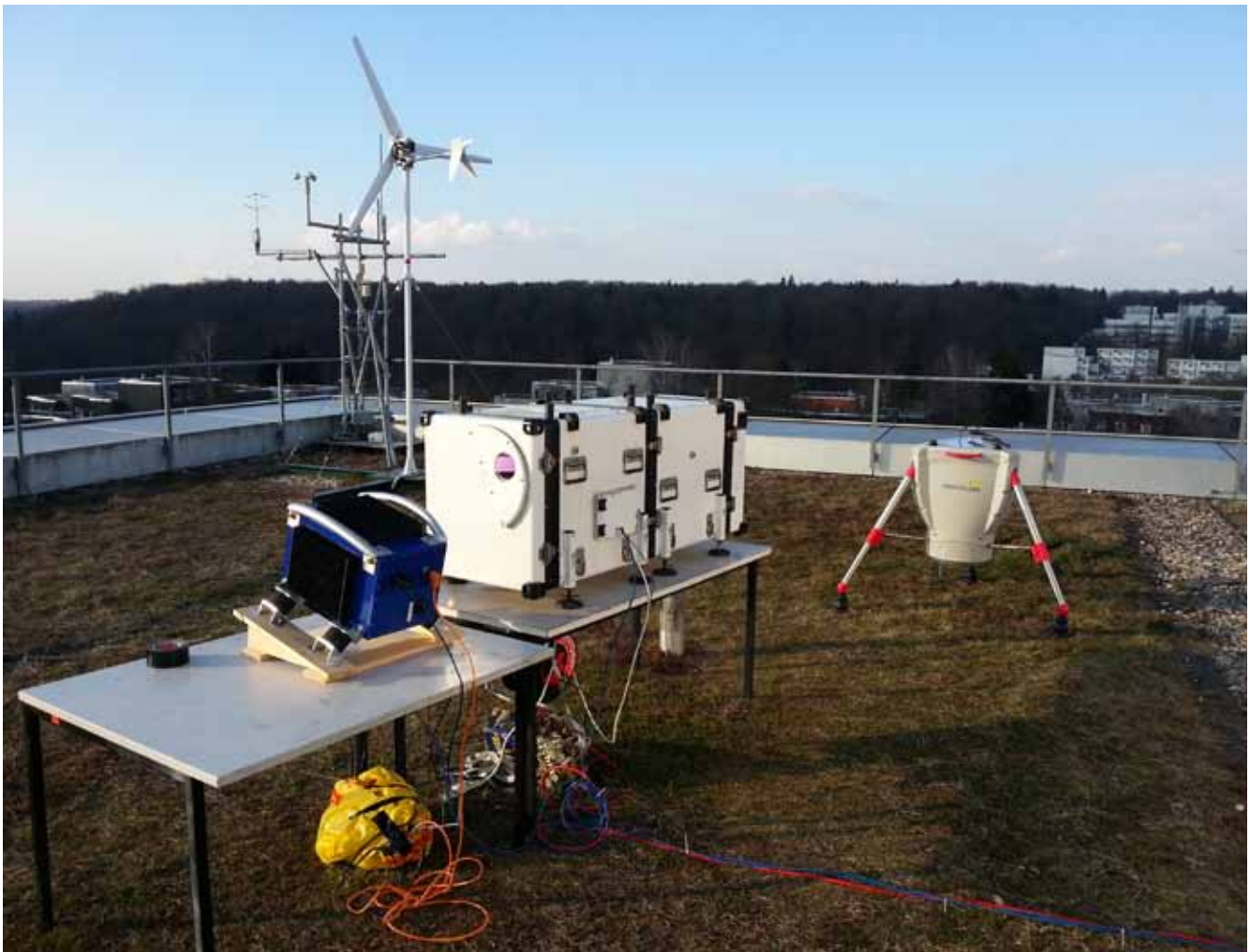

Figure 3: Testing of Whirlwind 1 (left) and other wind lidar instruments at SWE Stuttgart, March 26th 2014

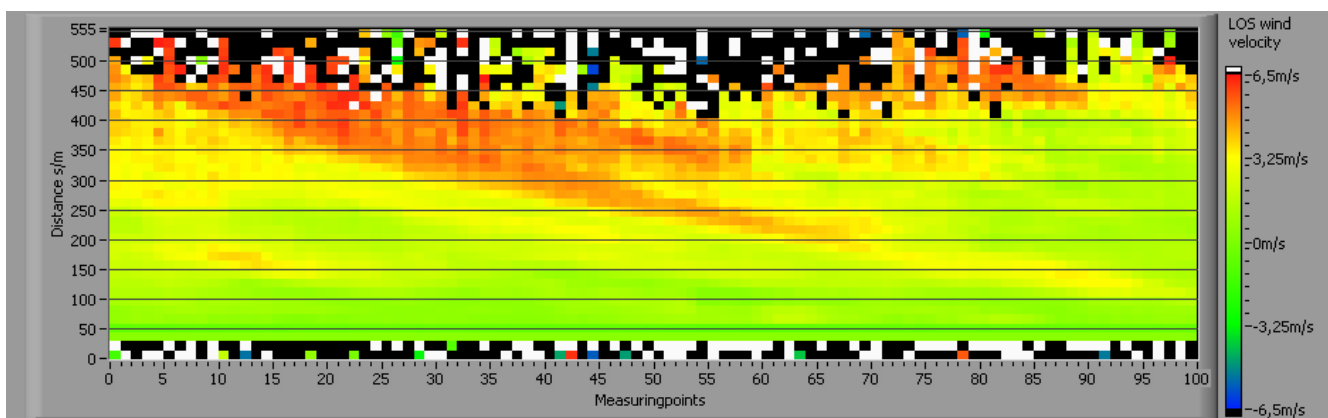

Figure 4: Wind speed measured in a laboratory test through the window on 10 July 2014 at a zenith angle of approx.  $60^\circ$ . Measuring points corresponds to the time in seconds. 10,000 single pulse data were averaged which corresponds to a 1 s averaging.





Figure 5: Mounting of Whirlwind 1 and a Leosphere WINDCUBE® lidar combined with the Stuttgart Wind Energy (SWE) Scanner from DEWI GmbH, Wilhelmshaven, on a wind turbine in *alpha ventus*, October 20th 2014.

Courtesy: Jan Anger, University of Stuttgart, Germany

#### Partners:

ForWind - Center for Wind Energy  
Research, University of Oldenburg  
(Coordinator)  
Chair of Wind Energy (SWE),  
University of Stuttgart  
AREVA Wind GmbH, Bremerhaven

# Generation of Realistic Turbulent In-Flow Conditions by an Active Grid –Stochastic Analysis of The Resulting Force Dynamics on 2D Segments of Airfoils with Active Control Units

Carl von Ossietzky Universität Oldenburg, Institute of Physics, Research Group Turbulence, Wind Energy and Stochastics (TWiSt)

Gerrit Kampers, Agnieszka Hölling, Michael Hölling, Joachim Peinke

Funding: German Research Foundation (DFG), Ref.Nr. PE 478/15-1

Duration: 01/2013 – 12/2015

## Introduction

Wind turbines work within the atmospheric boundary layer (ABL), which is dominated by turbulence. Such turbulent flows feature gusty structures, which have a big impact on mechanical load fluctuations and are considered to increase wind turbine failure rates [1]. Active and passive flow control elements represent a promising approach for the reduction of these

changing forces and loads, respectively. In the present project, a new method for wind tunnel experiments will be adopted, that allows an advanced investigation of the dynamics of aerodynamic forces acting on airfoil segments. Based on an analysis of offshore wind data, the dominant wind features will be reproduced in the wind tunnel by means of an active grid. To study the resulting force dynamics, a stochastic analysis method is worked out, that allows for a quantitative analysis of the dynamical performance of airfoils with and without flow control elements.

## Project Description

### Characterization of realistic turbulent inflow conditions

Wind turbines are exposed to fluctuating wind speeds and directions. Locally at the rotor blades, these fluctuating wind conditions are superimposed with the rotational movement of the blades and define the re-

sulting inflow. For the generation of these inflow conditions for wind tunnel tests, data from the offshore measurement platform FINO1 was analyzed. Based on this data, the resulting inflow on a rotating blade segment can be calculated for arbitrary rotational frequencies  $\omega$  and distance from the hub  $r$ , as illustrated in fig. 1.

This procedure results in a time series for the inflow angle  $\gamma(t|r)$ , where its fluctuations correspond to those in the local angle of attack. These angle of attack fluctuations were analyzed by means of increment statistics, where the increment

$$\partial_\tau \gamma = \gamma(t+\tau|r) - \gamma(t|r)$$

describes the change of  $\gamma(t|r)$  for the time lag  $\tau$ . Figure 2 shows an example of a probability density function (PDF) of the resulting angle of attack increments. It can be seen that fluctuations as large as  $5^\circ$  are occurring frequently. Such extreme fluctuations are heavily underestimated by Gaussian statistics used in industry standards [2].

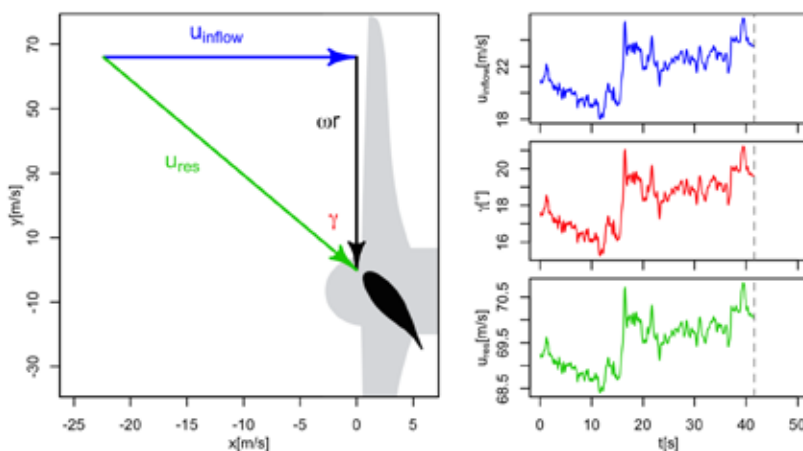

Figure 1: Superposition of the wind velocity  $u_{inflow}$  and the blade rotational speed  $\omega r$ . The resulting inflow  $u_{res}$  and the fluctuations of the angle  $\gamma$  correspond to the inflow of the blade in turbulent conditions

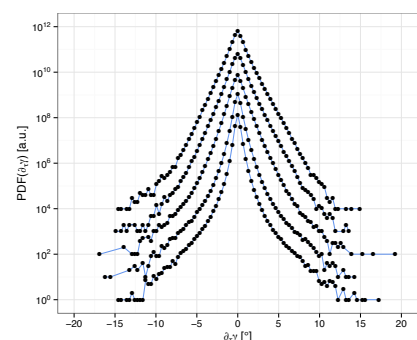

Figure 2: PDF of increments of the resulting angle of attack fluctuations at a wind turbine blade segment at  $r = 55m$  based on wind data. The graphs are vertically shifted. From bottom to top  $\tau$  takes the values of 0.5, 1, 5, 15 and 30s.

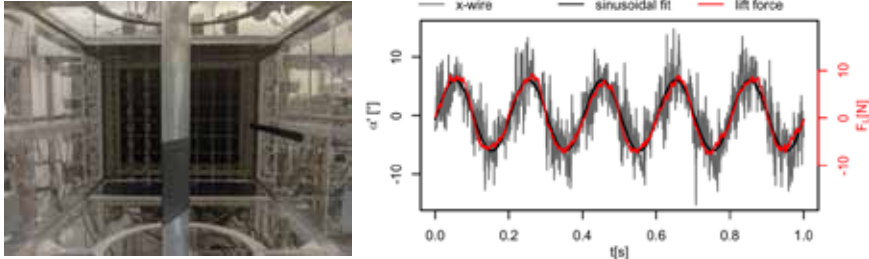

Figure 3: Left: A profile mounted in the closed test section of the wind tunnel downstream of the active grid. Right: Measured time series of flow angle fluctuations (gray) at the position of the leading edge of the profile in the wind tunnel with a sinusoidal fit and the measured aerodynamic lift force of the installed profile (red).

It can be seen that the well-known intermittent statistics of atmospheric turbulence transfer directly to the resulting local inflow at the wind turbine blades and therefore will also influence their mechanical loads.

#### Measurement of aerodynamic quantities

An important goal of the present project is the experimental test of the performance of airfoils under realistic inflow conditions. As shown above, the resulting inflow on wind turbine blades shows intermittent statistics on a variety of timescales. To be able to generate dominant features in a reproducible way, an active grid was used. In a first experiment, only the vertical axes of the active grid have been used to generate quasi 2D sinusoidal inflow angle fluctuations with different timescales and amplitudes on a 2D airfoil segment. Fig. 3 (left) shows the experimental setup.

Fig. 3 (right) shows measured inflow angle fluctuations at the position of the leading edge of the profile, without the profile mounted. The red line shows a measurement of the lift force acting on the airfoil using the same inflow setup. It is clearly visible that the fluctuations of the inflow angle transfer to the aerodynamic forces acting on the airfoil. With this simplified approach we are able to test the influence of characteristic fluctuations on a variety of scales. In future work, we will advance the actuation of the active grid to reproduce realistic inflow angle fluctuations according to the statistical properties determined from wind data.

#### Stochastic analysis

Another main task of this project is the development of a method to evaluate the performance of airfoils under turbulent inflow. We propose a stochastic Langevin approach, which decomposes the dynamics of the measured force fluctuations  $F(t)|\alpha$  into a deterministic and a stochastic part. In this way, the dynamics in the force can be described by the Langevin equation

$$\frac{d}{dt}(F(t)|\alpha) = D^{(1)}(F(t)|\alpha) + \sqrt{D^{(2)}(F(t)|\alpha)} \cdot \Gamma(t)$$

where  $\Gamma(t)$  is Gaussian  $\delta$ -correlated white noise. The drift and diffusion coefficients  $D^{(1)}$  describes the deterministic relaxation of the system to its desired steady state  $D^{(1)}=0$ . The diffusion coefficient  $D^{(2)}$  describes the stochastic part of the system. Both coefficients can be obtained directly from measurement data. A first test of this method was carried out using measured force dynamics on a self-adaptive camber Clark-y profile, developed at TU Darmstadt. Fig. 4 shows the drift coefficient of the profile in comparison to the fixed Clark-y baseline profile under the same turbulent inflow conditions. It is visible that the slope of the deterministic drift around the fixed point  $D^{(1)}=0$  is increased for the flexible profile. We consider this method promising for the quantitative evaluation of the dynamical performance of airfoils [3].

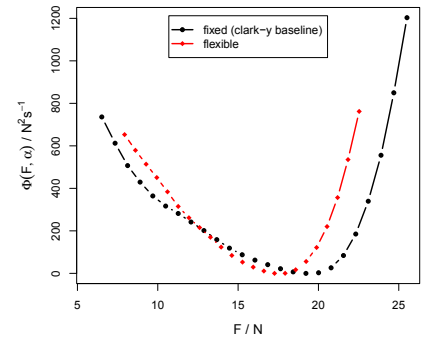

Figure 4: Deterministic drift of the lift force acting on the self-adaptive camber profile compared to its fixed baseline profile

#### Summary

The presented project is concerned with the development of an analyzing method of flow control equipped airfoil segments under realistic turbulent inflow conditions. So far FINO1 wind data was analyzed to define the needed inflow conditions for wind tunnel experiments. An active grid was used to generate quasi 2-dimensional sinusoidal flow fluctuations under which the dynamical reaction of the aerodynamic lift force of a standard profile has been measured. Additionally, the applicability of the Langevin approach for a quantitative analysis of airfoils in turbulent inflow was shown.

#### References

- [1] Taver, P.; Qiu, Y.; Korogiannos, A.; Feng, Y.: The correlation between wind turbine turbulence and pitch failure, EWEA 2011, p.149
- [2] Mücke T., Kleinhans D., Peinke J.: Atmospheric turbulence and its influence on the alternating loads on wind turbines, Wind Energy 14, p. 301, 2011
- [3] Kampers, G.; Cordes, U.; Tropea, C.; Peinke, J.; Hölling, M.: Stochastic analysis of aerodynamic forces acting on a self-adaptive camber airfoil in turbulent inflow, publication in the context of the AIAA AVIATION conference 2015 in progress

# Traceable Acquisition of Meteorological Data

Universität Bremen  
Bremen Institute for Metrology,  
Automation and Quality Science (BIMAQ)

Michael Sorg, Onno Schröter,  
Werner Behrendt

Funding:  
Federal Ministry for the Environment,  
Nature Conservation, Building and  
Nuclear Safety (BMUB)  
Ref.Nr. 0325468A

Duration: 11/2012 – 10/2015

## Introduction

Anemometers and tail vanes are wind sensors, which are sensitive measuring instruments installed to acquire meteorological data in order to calculate the energy yield of wind turbines and wind farms. Various factors affect the acquisition and transmission of measurement data. Among them are the usual influences due to weather conditions but also incidents like a bird sitting on an anemometer on top of a met mast distort the measurement results. Thus, research partners from Ammonit Measurement, Adolf Thies, Deutsche Windguard, and digiraster Tetzner together with scientists of the University of Bremen initiated the research project “Traceable acquisition of meteorological data (RealMe)” in order to improve both the reliability and the accuracy of measured meteorological values.

## Project Description

Site assessment reports based upon meteorological data are the basis for the financial planning and the design of wind farm projects. In order to determine the wind energy potential of a site precisely, a comprehensive and accurate measurement of wind

speed, wind direction, air pressure, relative humidity and air temperature over a period of at least 12 months is essential.

Already minor deviations of measurement data lead to a significant deviation of the prediction of the wind energy potential and increase the risk of uneconomic operation of a wind farm. For example, a measurement error of only 3 % of the wind speed can lead to seven-digit economic damage-costs for a wind farm installation that requires eight-digit investments.

The necessary sensors are installed on up to 200 m high met masts, which are exposed to shadowing effects (Fig. 1) and to varying environmental conditions, like storm, rain, snow, ice and dirt. As wind energy farms

are installed in almost all climate zones of the world the sensors on the met mast have to resist even extreme weather conditions, have to work reliably far away from any street or power supply station and have to deliver a maximum data quality.

Icing of sensors, for example, is an increasing challenge for the site assessment. In mountainous areas, tests with heated sensors were carried out in order to prevent icing effects [1]. Results also from tests in climate- and wind tunnels show that heated sensors cannot reliably prevent icing on sensor surfaces. Based on these results, it is essential to detect icing parallel to wind-speed-measurement with additional sensors. The RealMe project partners will focus on four topics to find solutions for the existing

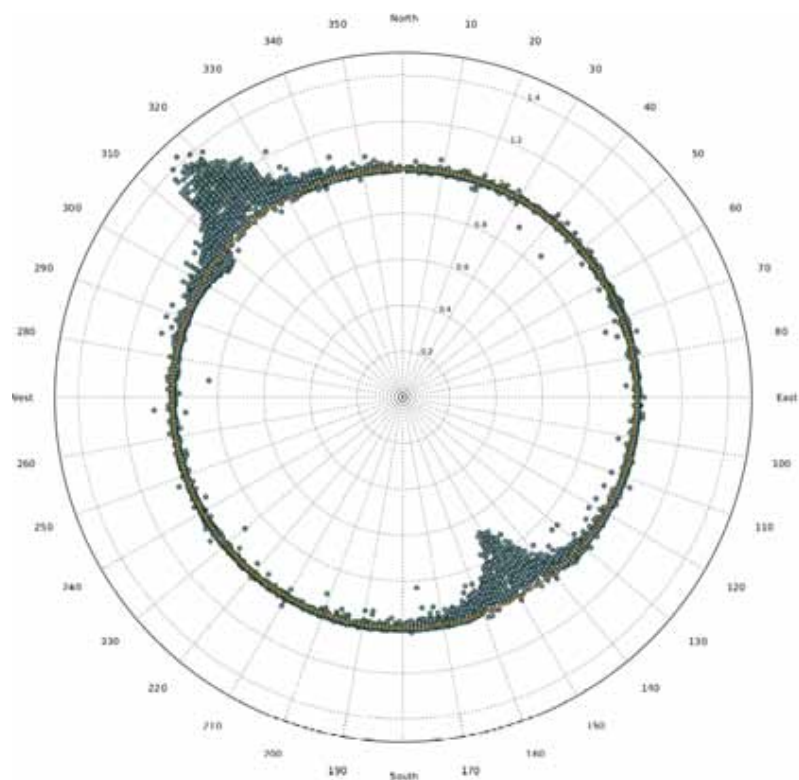

Figure 1: The Polar diagram shows the wind direction-dependent influence of the mast wind shadow on the wind speed measurement [Ammonit]

challenges in the upcoming three years. Traceability of the measured data: Small measurement deviations can lead to a significant deviation of the assessment of the wind energy potential of a site (as mentioned above). Thus, calibration of the instruments is an important topic and solutions for different sensors are estimated in the project. Additionally, the uncertainties of the measurements have to be determined in order to be able to calculate the uncertainties of the wind energy potential. This uncertainty calculation is only possible if the traceability of the measured data is ensured by measuring according to international standards (SI units) and using certified calibration chains. These working topics are accompanied by the examination of complementary sensors and embedded systems, which deliver additional information to ensure highest data accuracy in the future.

Consistency of measurement data: Faulty values from sensors not measuring properly should be identified by comparison with other measured quantities. For example, ice-effects on the instruments should not affect the measurement results or should be automatically corrected by intelligent algorithms. Alternatively, the icing-influenced

results are automatically excluded from the measurement series. Therefore, plausibility checks and correction algorithms as well as additional controlling instruments recording the environmental conditions such as ice sensors will be developed and examined.

Secure transmission: Manipulation of measured data has to be prevented in order to ensure a correct assessment of the site's wind energy potential. Thus, the measured values should be digitally signed and encrypted prior to data transmission. Appropriate microelectronic circuits integrated in the sensors and cross-linked digital systems are developed and tested for these purposes (Fig. 2).

Steady operation: Newly designed independent power supply solutions should ensure a steady operation of the measuring systems in order to guarantee the long-term availability of measurement data. In addition to power-saving switches, the project team considers the approach of Energy Harvesting. Therefore, the consortium examines different approaches for the generation of the necessary electrical energy for the sensors. Considered locally available sources are ambient temperature, vibration and air flow.

## Summary

Goal of the co-operative research project is to develop and enhance measuring systems for meteorological data. The results will increase reliability, security and traceability of the measured data for evaluation by developers, operators of wind turbines and service providers. For compliance with enhanced quality-parameters, the sets of measurement-data in comprehension of all components of the measuring chain should be upgraded with digital signatures. The partners evaluate methods to digitize and digitally sign measurement values directly in the sensor. Microelectronic circuits will be developed for the integration in meteorological sensors which are connected by digital bus-systems for secure data transfer. The development of data plausibility checks requires additional sensors which will be added to the meteorological systems for detecting influences on data quality.

During the project the project partners use the research wind turbine of the University of Bremen and the wind tunnels of Deutsche WindGuard, which offer a nation-wide unique research infrastructure and an ideal testing environment.

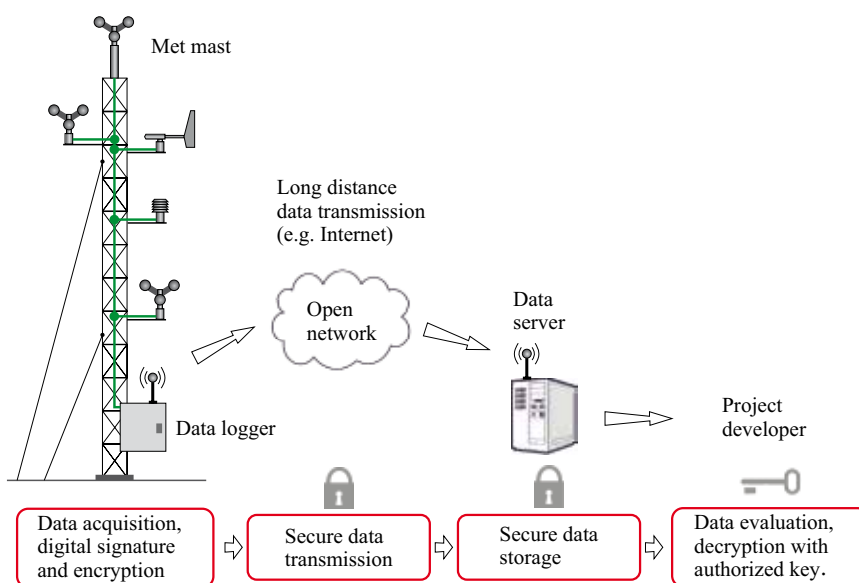

Figure 2: Acquisition of meteorological data with an extension of the data record with encryption and signature, and including all components of the measurement chain

## References

- [1] Seifert, H.: Betrieb von Windenergieanlagen unter Vereisungsbedingungen. AUF WIND 99, St. Pölten. 1999.

# Predicting Underwater Noise due to Offshore Pile Driving ("BORA")

Leibniz Universität Hannover  
Institute of Structural Analysis (ISD)

Raimund Rolfes, Jörg Rustemeier,  
Tanja Griebmann, Tobias Bohne,  
Cristina Díaz-Cereceda

Funding: Federal Ministry for Economic  
Affairs and Energy  
Ref.Nr. 0325421

Duration: 03/2012 – 10/2015

## Introduction

Numerous offshore wind farms are planned, already granted, or currently under construction within Germany's exclusive economic zone (EEZ). The foundations of the wind turbines are usually built by pile driving, e.g. for monopile, tripile, tripod constructions.

This technique induces underwater noise, which can be measured in distances of 20 km and more to the construction site. In the near surroundings of the pile, sound energy levels often exceed the limit values prescribed by the German authorities to protect marine mammals, which are a single event sound pressure level (SEL) of 160 dB re 1  $\mu$ Pa and a maximum peak level ( $L_{peak}$ ) of 190 dB re 1  $\mu$ Pa in a distance of 750 m to the pile. Therefore, various sound-damping techniques are currently in development or in field trial.

## Project Description

The global target of BORA is to develop a profound calculation model to predict waterborne noise due to offshore pile driving. This includes especially models to predict the sound development at the source due to

pile deformation and vibration, the sound transmission into water and soil and the consideration of the sound attenuation due to the air-water mixture produced by bubble curtains or other noise mitigation methods.

An important step when developing such models is the thorough validation of the approaches regarding their ability to accurately account for the sound origination at the pile, the transmission into water and soil, and the sound attenuation due to possible mitigation measures. For this purpose, three extensive offshore measurement campaigns will be performed in different wind farms in the German North Sea.

After validation, the detailed simulation model will be adapted to other offshore structures with different boundary conditions. Due to the complexity of the resulting model and the necessary access to substantial computing capacities and specialist simulation software, this model can only be executed by experts in the field of numerical simulation. Therefore an additional stand-alone expert system will be developed, which will enable third party users to calculate basic noise predictions for offshore pile driving. Finally, standard datasets will be compiled to allow a review of future computation models.

The project is organized in four work packages, each of them dealing with a specific subdomain of the wave propagation problem, which will be solved by one of the project partners. Each of the work packages includes deep documentation work and the publication of the major results.

### AP 1:

TUHH/GBT describe the pile deformation and thus the vibration on the pile surface which causes the hydroacoustic input into the water column. Furthermore, the near field of the structure-borne sound is modeled.

### AP 2:

CAU/IfG investigate the structure of the subsurface. Additionally, the far field of the structure-borne sound is described.

### AP 3:

LUH/ISD investigate the attenuating effect of different sound mitigation measures and set up corresponding models, which can be included into the overall sound propagation model. Thereby, emphasis is put on the complex bubble dynamics and thus the functional principle of bubble curtains.

### AP 4:

TUHH/IMB develop numerical models for the propagation of the waterborne so TUHH/IMB develop numerical models for the propagation of the waterborne sound in the near field as well as in the far field and set up the overall model including source and mitigation measures.

The coupling of all subdomain models will allow the creation of a complex integrated model, which enables a detailed investigation of the resulting underwater sound due to pile driving.

## Summary

Within AP 3, reliable parametric numerical models for the prognosis of the mitigation effect of bubble curtains and further sound attenuation concepts are being developed. To reach this goal, a suitable finite element approach has been defined. This model is based on the wave equation and takes into account the different physical phenomena involved in the process. Some of these phenomena are the increment of the sound scattering at the omnidirectional eigenfrequency of the bubble or the interaction between two or more bubbles.

In a first step, a mathematical model for the mitigation concept of the bubble curtain,

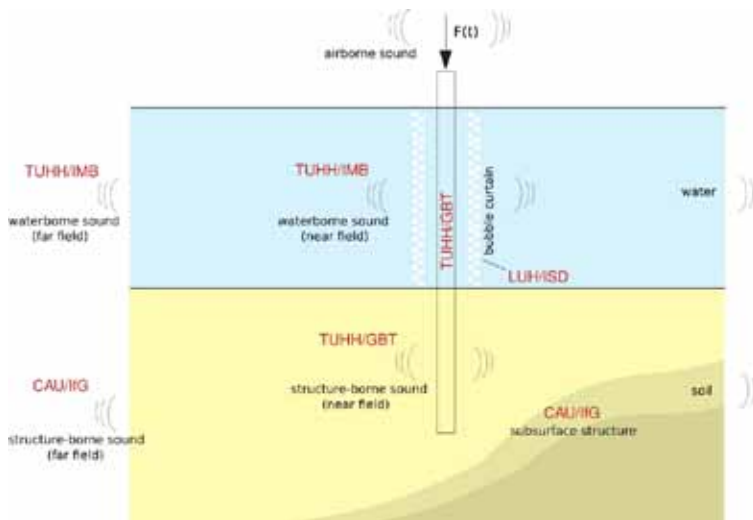

Figure 1: Division of the wave propagation problem into specific subdomain models (Source: BORA)

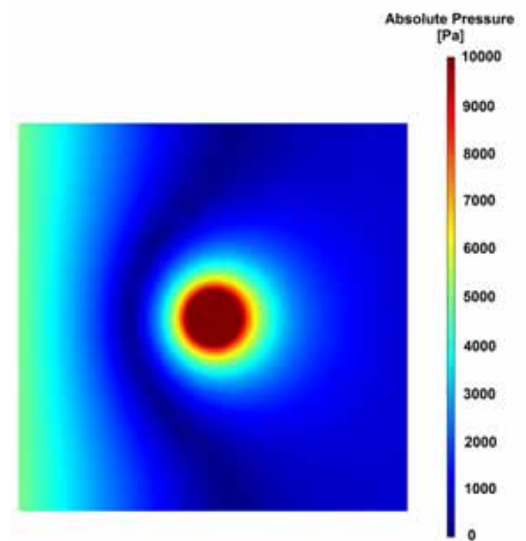

Figure 2: Sound scattering at the bubble eigenfrequency

developed within a recently completed research project [3], was upgraded, taking into account effects of sound scattering and measured bubble size distributions.

As a next step, simulation models for bubble curtains and typical further concepts [1, 2] are being developed. Regarding the bubble curtain, numerical studies simulating the local interaction between single bubbles are analyzed. The obtained results are compared with the upgraded model of the previous work package as verification.

The results of the numerical modeling will be validated with data from different offshore experiments, in which underwater sound pressures for several foundation types and distances are measured. These comparisons will be used to calibrate the models.

The validated computational models will be implemented into the overall acoustic propagation model of TUHH/IMB. To allow a global calculation with an affordable computational cost, the bubble curtain will be defined as an equivalent fluid with complex frequency-dependent properties. These properties are estimated from detailed numerical simulations in order to reproduce

all the physical phenomena involved in the process.

Once the bubble curtain is added to the global acoustic propagation model, some optimizations can be performed, if required. Finally, sensitivity analyses for different boundary conditions and properties of the mitigation concepts will be carried out.

Within the last phase of the project, LUH/ISD will coordinate the compilation of an expert system for estimating the pile driving noise during OWT construction. All results

of the above mentioned work packages will be integrated into the underlying knowledge base.

## References

- [1] Elmer, K.-H.; Betke, K.; Neumann, T.: Standardverfahren zur Ermittlung und Bewertung der Belastung der Meeresumwelt durch die Schallimmission von Offshore-Windenergieanlagen, final report of the BMU research project no. 0329947 (2007).
- [2] Koschinski, S.; Lüdemann, K.: Stand der Entwicklung schallmindernder Maßnahmen beim Bau von Offshore-Windenergieanlagen, survey on behalf of the Federal Agency for Nature Conservation (BfN) (July 2011).
- [3] Rustemeier, J.; Neuber, M.; Griebmann, T.; Ewaldt, A.; Uhl, A.; Schultz-von Glahn, M.; Betke, K.; Matuschek, R.; Lübken, A.: Konzeption, Erprobung, Realisierung und Überprüfung von lärmarmen Bauverfahren und Lärminderungsmaßnahmen bei der Gründung von Offshore-WEA, final report of the BMU research project no. 0327645 (2012).

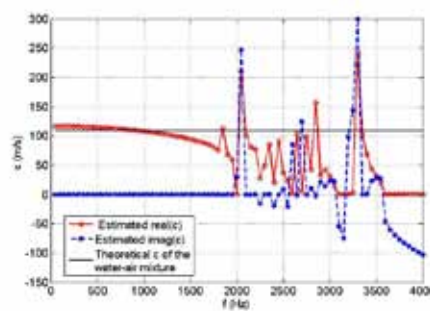

Figure 3: Equivalent sound speed of a bubble curtain

# HyproWind: Realistic Underwater Sound Scenarios Based on Forecast Modelling and Monitoring Regarding Piling Noise During Wind Farm Construction in the German North Sea

Leibniz Universität Hannover  
Institute of Structural Analysis (ISD)

Raimund Rolfes, Moritz Fricke,  
Tanja Griebmann

Funding: Federal Ministry for the  
Environment, Nature Conservation,  
Building and Nuclear Safety (BMUB)  
Ref.Nr. 0325212

Duration: 09/2010 - 12/2013

## Introduction

The construction of offshore wind energy converters and voltage transformer platforms often requires the operation of high-energy pile driving equipment to mount the support structure at the sea bed. Today it is well known that underwater sound caused by piling activities can seriously affect the behaviour and physical health of marine mammals. In order to minimize negative effects on the marine environment due to construction noise of projected offshore wind energy converters it is necessary to have a realistic forecast of the expected underwater sound exposures.

There have been several research projects attending to underwater piling noise in the past ([1], [2]). During these projects single offshore construction projects like the erection of alpha ventus were investigated with respect to underwater noise. The main attention was paid to acoustic measurements and their consistent evaluation using the values  $L_{eq}$ , SEL and  $L_{peak}$ . Considering the large number of expected piling activities in the German North Sea it will be indispensable to look at cumulative effects as well as occasionally overlapping noise emissions to

evaluate the ecological relevance. Currently there is no reliable forecast model available to give an answer to the questions mentioned above. Furthermore there is the need for a uniform mapping of the expected underwater noise immissions to allow for the ecological evaluation during the approval procedure of construction activities.

To this end a cooperation project between the Institute of Structural Analysis (ISD), the German Wind Energy Institute (DEWI) as well as the German Federal Maritime and Hydrographic Agency (BSH) was established. The project dealt with the implementation of a forecast tool for underwater noise immissions due to pile driving in the German North Sea and the preparation of uniform noise maps.

## Project Description

The numerical approach incorporates a coupling between the finite element method (FEM) for the pile including the surrounding water/bottom-column and the parabolic equation (PE) for the efficient calculation of

long-range propagation [3]. The results of the FEM simulation are applied to the PE algorithm at an artificial cylindrical coupling interface forming an envelope around the pile. Fig.1 shows the results of the FEM as a contour plot as well as the complex sound pressure on the coupling interface (red line).

Major attention was paid to the coupling procedure and the long-range propagation calculation using the PE method. In shallow water sound propagation like in the German Bight, the transmission loss is significantly influenced by the shape of the seabed (bathymetry) as well as its geoacoustic properties like density, sound speed and attenuation coefficient. In order to estimate the relative role of the bathymetry, a numerical case study was conducted by introducing an artificial shallowness of finite length.

Fig. 2 exemplarily shows a scenario with a maximum calculation length of 75km with an artificial sandbank ranging from 10 to 20km. Within the region of the sandbank, the water depth is assumed to be 15 m whereas the rest of the domain exhibits a water depth of 30 m. It can be seen that the

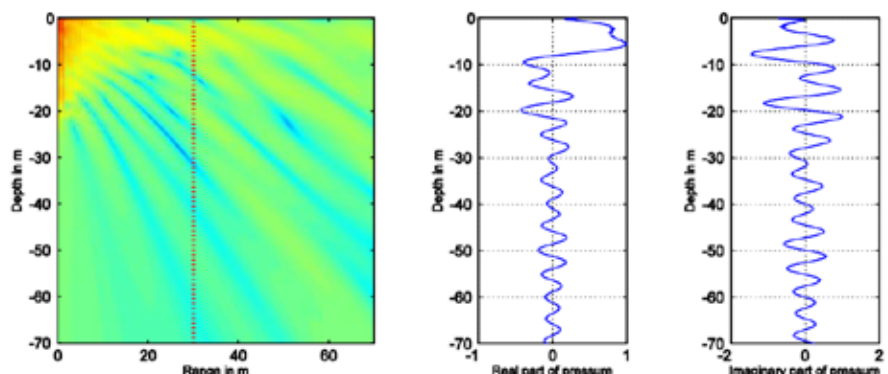

Figure 1: Results and coupling interface (left); Complex sound pressure on the coupling interface (right)



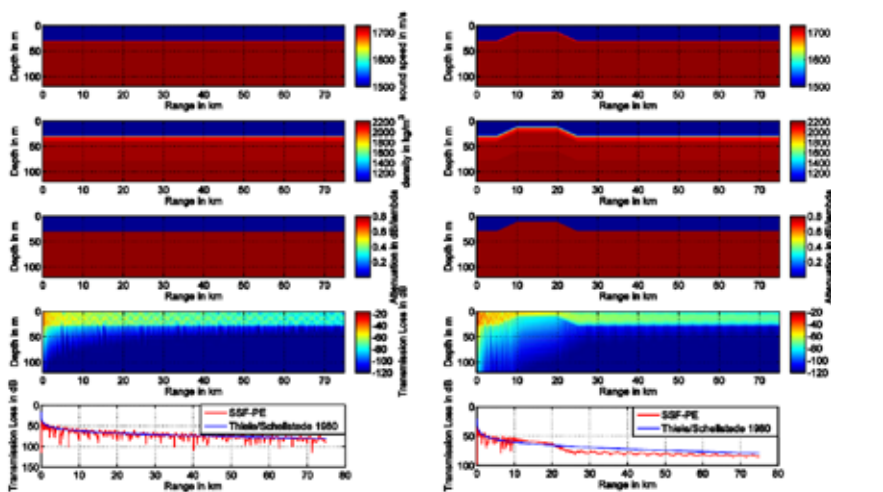

Figure 2: Numerical case studies based on the PE method; left: Flat bathymetry; right: Sandbank of finite length

transmission loss significantly increases if the sandbank is included in the simulation. The example shows that it is necessary to take the bathymetry into account, especially when long-range propagation is considered.

During the project the model was validated based on in-situ measurements that were gathered during the construction of the wind farms Borkum West II and BARD Offshore 1. Fig. 3 shows the comparison of simulated and measured results for the validation case Borkum West II up to a distance of 18400 m as well as a parametric study concerning the sound speed in the soil. Therefore the

sound speed  $c_b$  was assumed to be 1.00, 1.05, 1.10 and 1.20 times the pure compressional wave speed  $c_{b0}$  in the soil (red lines). Moreover, the results assuming the soil as an equivalent fluid are shown (black lines).

It can be concluded that the model and the underlying assumptions are appropriate, although there are some deviations at low frequencies concerning the measuring point at 18400 m. These deviations might be due to reflections at very deep soil layers or even at the bedrock that are not included in the model.

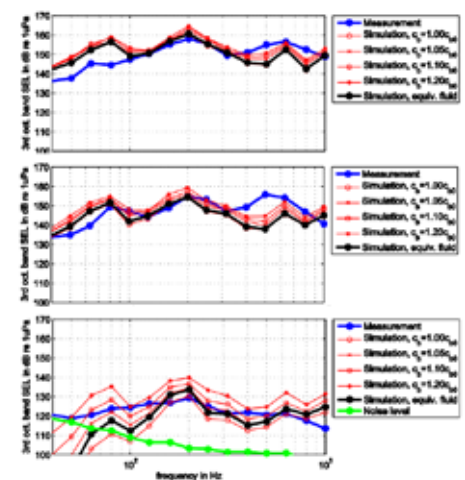

Figure 3: Measured and simulated 3rd octave band sound exposure levels for different sound speeds in the soil. Top: R=1500m; Mid: R=2900m; Bottom: R=18400m; R: Distance from the construction site.

## Summary

The developed model and the validation facilitate a better understanding of the sound generation and propagation mechanisms during pile driving and moreover offer the possibility to perform piling noise predictions up to a distance of 20 km [4]. In a next step, the model is intended to be used for a multi-parametric analysis in order to develop simplified formulas for piling noise predictions.

## References

[1] DEWI/CRI/itap (2004). Standardverfahren zur Ermittlung und Bewertung der Belastung der Meeresumwelt durch die Schallimmission von Offshore-Windenergieanlagen – „Schall I“. Abschlussbericht zum Forschungsvorhaben FKZ 0327528 A des Bundesministeriums für Umwelt, Naturschutz und Reaktorsicherheit

[2] Elmer, K.-H.; Betke, K.; Neumann, T. (2007). Standardverfahren zur Ermittlung und Bewertung der Belastung der Meeresumwelt durch die Schallimmission von Offshore-Windenergieanlagen – „Schall II“. Abschlussbericht zum Forschungsvorhaben FKZ 0327528A des Bundesministeriums für Umwelt, Naturschutz und Reaktorsicherheit. Mitteilungen des Instituts für Statik und Dynamik der Leibniz Universität Hannover, Nr. 08/2007

[3] K. B. Smith, Convergence, stability, and variability of shallow water acoustic predictions using a split-step Fourier parabolic equation model, *Journal of Computational Acoustics*, Bd. 9, Nr. 1, pp. 243–286, 2001.

[4] Fricke, M.; Neddermann, B.; Lübben, A.; Gabriel, J.: „Realistische Hydroschallszenarien auf der Basis von Prognosemodellen und Monitoring für den Bau von Offshore-Windparks in der deutschen Nordsee („HyproWind“); Abschlussbericht zum Forschungsvorhaben FKZ 0325212“, Hannover [u.a.], 2014

# Further Development and Testing of the Big Bubble Curtain (BBC) to Reduce Hydro Noise Pollution in Offshore Pile Driving

Leibniz Universität Hannover  
Institute of Structural Analysis (ISD)

Raimund Rolfes, Jörg Rustemeier,  
Tanja Griebmann

Funding: Federal Ministry for Economic  
Affairs and Energy  
Ref.Nr. 0325645D

Duration: 07/2013 – 12/2014

## Introduction

Pile driving for the installation of foundation structures for offshore wind turbines cause high noise levels in the water (underwater noise), which can be harmful to marine mammals. Underwater noise can lead to disturbances in the far field and to hearing damage in the close range. While the risk of direct injury of marine mammals can be reduced by scaring and a slow increase of the driving energy (soft start), disturbances can be minimized only by the reduction of noise emissions.

One existing noise mitigation method is the use of a Big Bubble Curtain (BBC). Therefore a nozzle hose is installed at the sea floor around the piling site. Compressed air is pumped into the nozzle hose and the raising bubbles build a dense wall around the sound source. The distance between the nozzle hose and the pile is designed in order to enclose the whole pile with bubbles even if the bubbles are drifted by sea currents. In the German bight of the North Sea the radius of a Big Bubble Curtain has to be at least twice the water depth.

The operated Big Bubble Curtain at the construction of FINO3 in the North Sea is

shown in Figure 1. Since 2008 Big Bubble Curtains are used at many construction sites in the North and Baltic Sea with different layouts. However the reduced sound pressure levels often exceed the limit values prescribed by the German authorities to protect marine mammals, which are a single event sound pressure level (SEL) of 160 dB re 1  $\mu$ Pa and a maximum peak level ( $L_{peak}$ ) of 190 dB re 1  $\mu$ Pa in a distance of 750 m to the pile.

## Project Description

In this research project technical aspects to the use of Big Bubble Curtains under the requirements of the construction of offshore wind farms in deep water (up to 50 m) and with the use of large installation vessels are examined, tested and further developed. Main topic is the optimization of individual technical components of the bubble curtain and the improvement of the noise reduction.

The effectiveness of the bubble curtain is examined by hydro sound measurements and by measuring the response of harbor porpoises.

Goal of this research project is the development of a large-scale method to the serial use of bubble curtains at the construction of offshore wind farms and the testing at the construction site of the offshore wind farm Global Tech I. Within the project new system components (technical optimization) for a more reliable handling and further improvements of the sound mitigation effect of the Big Bubble Curtain are further developed and tested. The goal of a lower disturbance on harbor porpoises is verified by measurements using passive acoustic monitoring (hydro sound measurements combined with porpoise detectors).

In addition to the optimization of individual technical system components of the nozzle hoses, the winches and the installation ves-



Figure 1: Big Bubble curtain installed at FINO3 construction site in 2008 [1]

sel a new method of bubble production is tested for the first time in the offshore environment. Therefore the nozzle hose is replaced by a new hose which is encapsulated with a micro-perforated membrane.

Within the finished research project "SCHALL3" [2] different nozzle hoses and membranes were tested and compared. Laboratory tests showed that very dense bubble curtains can be produced with the membrane in comparison with drilled nozzle holes. Figure 2 shows bubble curtains produced with a conventional nozzle pipe (a) and with a membrane (b) using the same amount of applied air volume. Additionally acoustical tests in a lake showed for the membrane a significant higher sound reduction within the important frequency range of 100 Hz to 400 Hz.

## Summary

After project start in 2013 the components of the new hose were ordered. The hose which is encapsulated with a micro-perforated membrane was built by the company Hydrotechnik Lübeck [3]. The installation vessel was prepared for the operation of the new sound mitigation system. A first attempt to install the membrane hose was canceled due to bad weather conditions a few days before Christmas. Finally the test took place at the beginning of 2014.

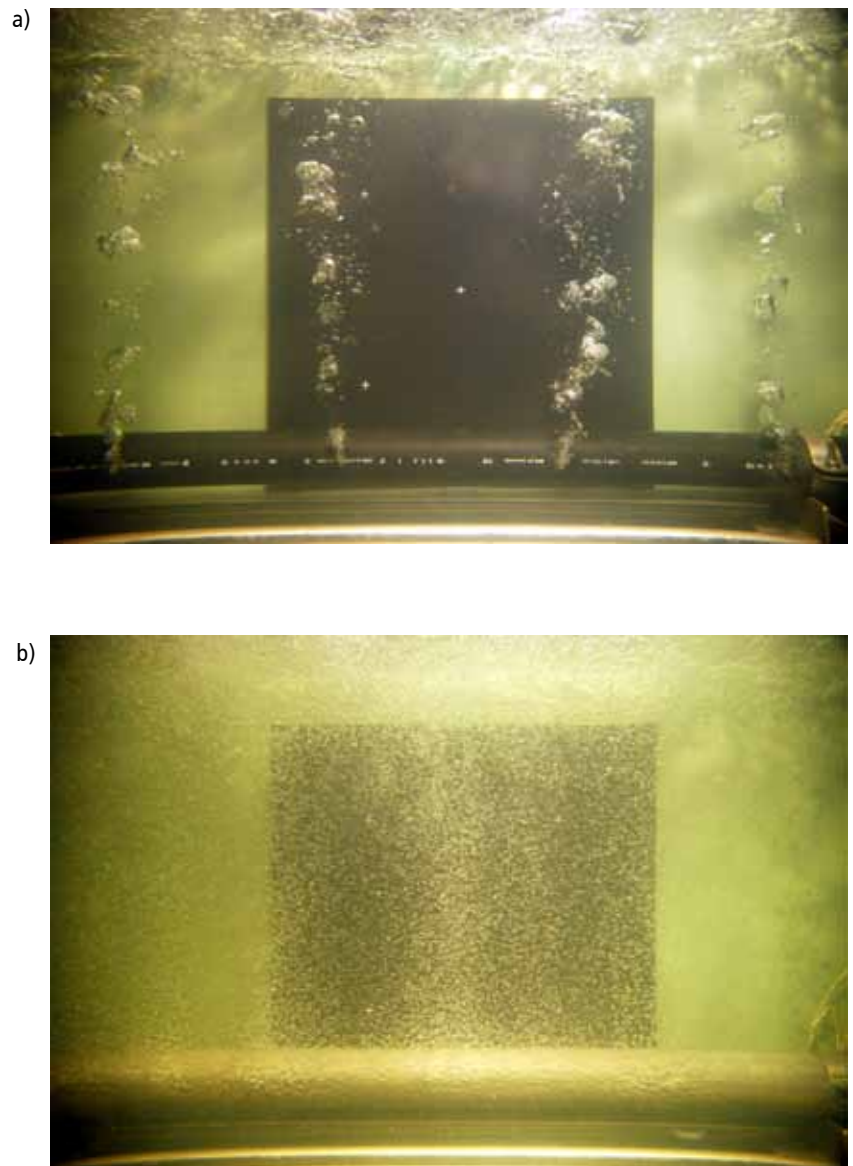

Figure 2: Bubble curtains produced (a) with drilled nozzle holes and (b) with a micro-perforated membrane. The applied air volume flow is 27 l/min each.

## References

[1] Griebmann, T.; Rustemeier, J.; Betke, K.; Gabriel, J.; Neumann, T.; Nehls, G.; Brandt, M.; Diederichs, A.; Bachmann, J.: Erforschung und Anwendung von Schallminimierungsmaßnahmen beim Rammen des FINO3-Monopiles, final report of the BMU research project no. 0325023A and 0325077 (2010).

[2] Rustemeier, J.; Neuber, M.; Griebmann, T.; Ewaldt, A.; Uhl, A.; Schultz-von Glahn, M.; Betke, K.; Matuschek, R.; Lübber, A.: Konzeption, Erprobung, Realisierung und Überprüfung von lärmarmen Bauverfahren und Lärminderungsmaßnahmen bei der Gründung von Offshore-WEA, final report of the BMU research project no. 0327645 (2012).  
[3] <http://www.hydrotechnik-luebeck.de>

# Development of a Program for the Design of Offshore Piles (IGtH-Pile)

Leibniz Universität Hannover  
Institute for Geotechnical Engineering

Mauricio M. Terceros Almanza,  
Martin Achmus

## Introduction

Pile foundations are used for the foundation of numerous offshore wind energy converters. Thus, the design of steel-pipe piles must be carried out in the most efficient way. At present different commercial programs are available to analyze the capability of deep foundations, but their results differ in some aspects significantly from each other. The reason for the discrepancies between results is not totally clear due to the fact that they are Closed-Sources (CSS). Furthermore, others implementations or improvements are impossible to accomplish. Hence, the program IGtH Pile has been developed at the Institute for Geotechnical Engineering (IGtH) since 2013, which allows analysis and designs of single piles subjected to axial and lateral loading. In contrast to other programs, IGtH-Pile offers the possibility to calculate pile foundations also under cyclic axial loading according to currently established regulations. It will also be possible to implement other processes of calculation in order to design offshore piles under cyclic lateral loading. It has to be mentioned that the program is being developed for research and academic purposes only.

## Project Description

The program has basically a modular design and is implemented under the concept object-oriented programming technique (OOP). In this regard, efficient organization of the source code is assured. Visual Basic .Net has been used as the programming language for the development of IGtH-Pile.

The input and output (IO) can be used through a windows-based Graphical User Interface (GUI) that provides a bilingual program whereby the user can choose the language between German and English, thereby ensuring it is user-friendly. In order to properly interpret of the results, they are displayed in graphics and tables in parallel form. The results can be exported to Microsoft Office Excel to facilitate the process of the information.

The options of analysis are found in a panel under the main tab, these are divided into sub topics like axially and laterally loading because their analysis is carried out separately as shown in Fig. 1.

For axially loaded piles, the axial capacity can be examined using the API [2]  $\beta$ -method and  $\alpha$ -method, which are established widely in practice, as well as some methods that are based on the evaluation of Cone Penetration Tests (CPT), which are called ICP-05, UWA-05, Fugro-05, NGI-05 [2] in non cohesive soils and ICP-Method (Jardine et al., 2005) [5] in cohesive soils.

For these methods the following capabilities are already implemented in the program:

- Determination of the axial capacity along the pile length in homogeneous and non-homogeneous soil. Detailed information of skin friction and end bearing.
- Estimation of the degradation of pile skin friction, with that a decrease of the static pile capacity due to cyclic axial loading by using interaction diagrams in relation with recommendations to the Draft chapter 13 of EA-Pfähle [4] (see Figure 2).
- Calculation of the Geotechnical ultimate limit state (ULS) design proof described in DIN 1054 [3].
- Generation of t-z and Q-z curves for static loads according to API [2].
- Calculation of local pile deflection at any depth as well as axial tip through the use of spring characteristic curves.

- Consideration of general scour and local scour in the analysis according to API [2].

With application of different spring characteristic curves proposed by O'Neill and Murchison (1984), Reese et al (1974), Kallehave et al. (2012), Soerensen (2012) in non cohesive soils and Reese, Cox, Koop (1975), Matlock (1970) in cohesive soils it is possible to calculate the following capabilities for laterally loaded piles:

- Calculation of lateral deflection, bending moment, shear force, and the ultimate lateral bearing capacity along the length of the pile.
- Determination of the pile head load corresponding to specific lateral head displacement or rotation.
- Calculation of the Geotechnical ultimate limit state (ULS) design proof described in DIN 1054 [3].
- Generation of p-y curves for soft and stiff clay as well as for sandy soils under static or cyclic load conditions according to API [2].
- Estimation of the critical embedded pile length, subject to reach the minimum pile head deflection ( $L_c, const$ ) according to the German EA-Pfähle [4].
- Determination of the pile head load corresponding to the failure state.
- Consideration of general scour and local scour in the analysis according to API [2].

Numerical techniques as Finite Element Method (FEM) have been implemented for the parametric analysis. The pile is idealized as a one dimensional beam element that is supported by nonlinear springs. This beam analysis can be applied using different theories such as Timoshenko and Euler-Bernoulli in the program. To resolve this model an iterative procedure is used that is carried out to achieve equilibrium of the forces and compatibility of deformation.

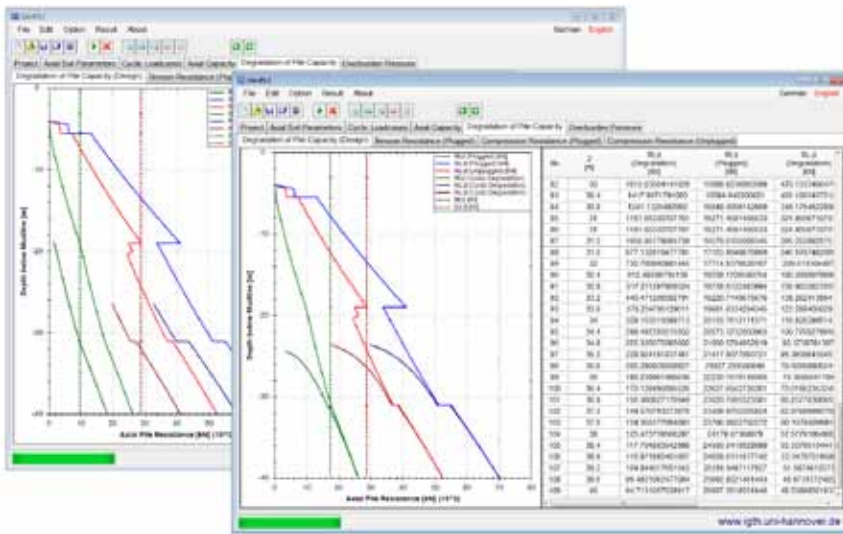

Figure 1: Analysis options for axially and laterally loaded piles

### Summary

The capabilities of the program IGTH Pile are described in this report. Based on the concept object-oriented programming technique (OOP) various methods of calculation are implemented in the program, recommended by standard regulations for the analysis and design of single piles under different load conditions (axially and laterally loaded piles). The employment of a windows-based Graphical User Interface (GUI) allows the presentation of the results in graphics and tables. Furthermore, it is feasible to implement new methods of calculation in the program, for example the analysis and design of the offshore-piles under cyclic load conditions

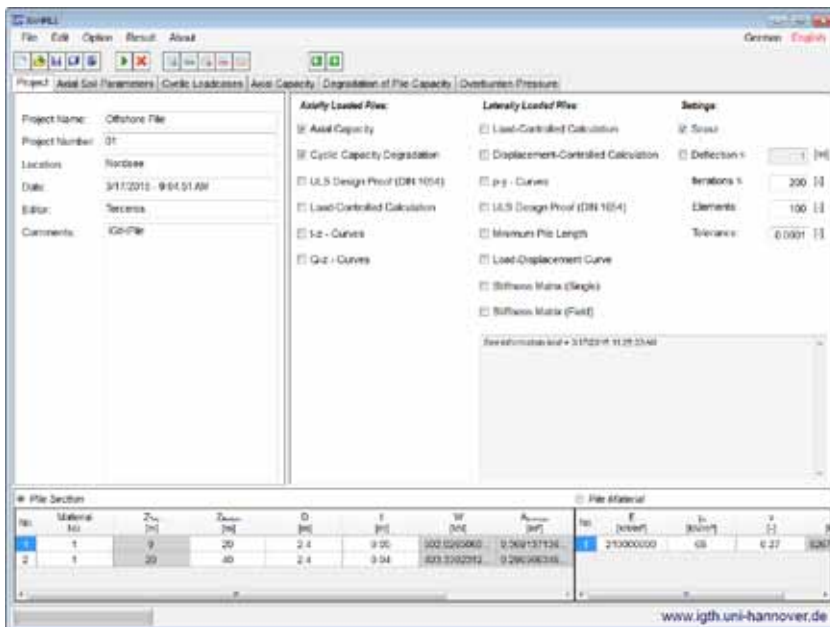

Figure 2: Pile capacity degradation due to cyclic axial loading dependent on pile length, degradation according to the EA-Pfähle "interaction diagram method" [4] (left), degradation by using the "damage variable" [1] (right)

### References

[1] Achmus, M.: Geotechnical Design of Foundation Structures for Offshore Wind Energy Converters in the German North Sea, Proceedings of International Symposium Coastal and Offshore Geotechnics, Hangzhou, China, November 16th-18th, 2012.

[2] American Petroleum Institute (API): Recommended Practice for Planning, Designing and Constructing Fixed Offshore Platforms – Working Stress Design, RP 2A-WSD. Version December 2000 and amendment October 2007.

[3] Deutsches Institut für Normung e.V. (DIN), DIN 1054:2010-02: Baugrund -Sicherheitsnachweise im Erd- und Grundbau – Ergänzende Regelungen zur DIN EN 1997-1, 2010 (in German).

[4] Deutsche Gesellschaft für Geotechnik e.V. (DGGT): Empfehlungen des Arbeitskreises Pfähle (EA-Pfähle), Berlin: Ernst & Sohn, 2. Auflage, 2012 (in German).

[5] Jardine, R., Chow, F., Overy, R., and Standing, J.: ICP Design Methods for Driven Piles in Sands and Clays, Imperial College, 2005.

# Cyclic Degradation of Axially Loaded Piles (2013)

Leibniz Universität Hannover,  
Institute for Geotechnical Engineering

Martin Achmus, Khalid Abdel-Rahman

## Introduction

The behavior of piles under cyclic loading is an important research issue. In particular offshore piles are often subject to intensively cyclic loads due to the strong wind and wave actions. Regarding axial cyclic loading, it is known that the pile capacity is in general decreasing with increasing number of load cycles. This occurs mainly due to a decrease of ultimate skin friction, whereas the tip resistance is believed to remain almost unchanged. For the safe and economic design of the required pile length the decrease of pile capacity with number of load cycles must be accurately predicted.

At the institute of the authors, a special numerical simulation scheme was developed. Herein, the system behavior under the first loading and unloading step is simulated by a finite element calculation. From the resulting shear strain amplitude in each element, the volume compaction to be expected under the considered number of load cycles is predicted by an approach derived from cyclic simple shear tests conducted by Silver & Seed (1971) [3]. This volume compaction is applied to the elements in the finite element model and results in a reduction of the normal stresses acting on the pile. In a subsequent loading stage, the (reduced) post-cyclic capacity of the pile is determined.

Figure 1: Schematic diagram showing the loading and unloading steps

## Project Description

The German 'EA Pfähle' recommendation (2012) [1] presents interaction diagrams which can be used in the design, for instance the interaction diagram proposed by Kirsch et al. (2010) [2]. In this project a numerical approach which principally facilitates the derivation of an interaction diagram and the calculation of the pile capacity under cyclic loading.

The idea of the proposed method is to predict the volume compaction of the soil elements beside a pile induced by cyclic shearing and to consider this volume change in the numerical simulation of pile behavior. The compaction effect due to shear strain was investigated previously by Silver & Seed (1971) [3] by performing cyclic simple shear tests on sand. It was found that the increase of volume compaction with number of load cycles is dependent on the amplitude of the cyclic shear strain applied. In contrast, no clear trend regarding the effect of the vertical stress was found. The computations were carried out using the finite element program system ABAQUS (Abaqus 2012). A two-dimensional (2D-axisymmetric) finite element model to investigate the axial deformation response of a pile in sandy soil was established. The numerical modelling was per-

formed for a steel tube pile with length of 50.0m, diameter of 2.0m and a wall thickness of 3.0 cm. A linear elastic material behavior of the piles was assumed with the parameters  $E = 2.10 \cdot 10^5$  MN/m<sup>2</sup> (Young's modulus) and  $\nu = 0.20$  (Poisson's ratio) for steel.

To account for the non-linear soil behavior, elasto-plastic material behavior was assumed for the soil elements. A Mohr-Coulomb failure criterion (parameters  $\phi'$ ,  $c'$ ,  $\psi$ ) was considered. A stress dependency of the oedometric stiffness modulus was implemented.

The numerical modeling was performed in several stages. In the first stage, the tensile load was then increased gradually until failure occurred. The result is the static load-deflection curve and the static pull-out capacity of the system.

The second stage is elucidated in Figure 1. The pile is loaded up to a load  $F_{max}$  and then unloaded to a load  $F_{min}$ . For each soil element the maximum and minimum shear strains  $\gamma_{max,i}$  and  $\gamma_{min,i}$  are determined. The cyclic shear strain amplitude can be obtained by

$$\gamma_{x,v,i} = (\gamma_{max,i} - \gamma_{min,i})/2$$

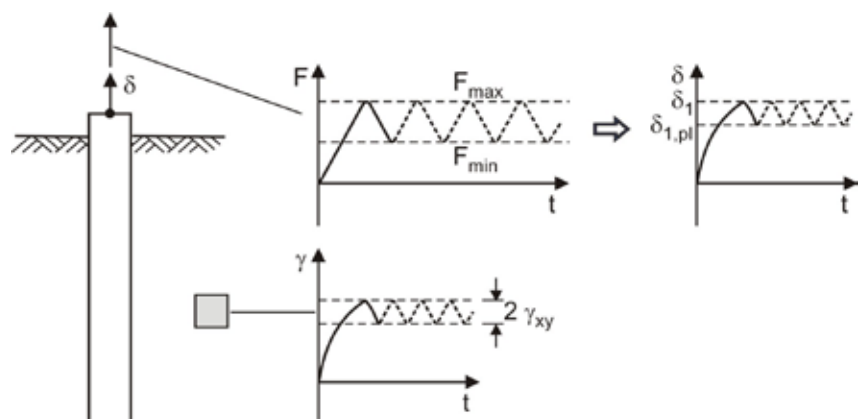

In the third stage, the pile is again loaded to  $F_{\max}$  and then these volume compactions are applied to the pile-soil system. The desired compaction or shrinkage of the elements was realized by applying temperature differences which induce the desired volume compaction. The result is a redistribution of stresses in the system; in particular a decrease of the horizontal stresses acting on the pile, and an increase of the axial pile heave under the applied load  $F_{\max}$ .

By repeating the third stage calculations for different number of load cycles, the dependence of cyclic pull-out capacity  $R_{k,N}$  on the number of load cycles is obtained. Furthermore, if  $R_{k,N}$  becomes equal to  $F_{\max}$ , the considered number of load cycles is identical to the number of load cycles leading to failure  $N_f$ . Thus, by a series of calculations  $N_f$  can be identified. Therefore, by variation of  $F_{\min}$  and  $F_{\max}$ , an interaction diagram for the system can be derived.

The static pull-out capacity calculated with the numerical model amounts to  $R_k=13.65$  MN. A maximum load of  $F_{\max}=0.76 \cdot R_k=10.40$  MN and subsequently unloading to  $F_{\min}=0.07 \cdot R_k=1.00$  MN was

applied. Hence, the normalized loads were now  $X_{\text{mean}}=0.42$  and  $X_{\text{cyc}}=0.34$ . Fig. 2 shows the reduction of pile capacity with the load cycle number. An almost linear decrease of  $R_k$  in the logarithmic scale, i.e. with  $\log N$ , is obtained. At a load cycle number of about 28,000 the decreased capacity is identical to the maximum load  $F_{\max}$ . This means that for the considered load combination the number of load cycles  $N_f$  leading to failure is  $N_f \approx 28,000$ . One point in the interaction diagram of the considered pile system is thus found. Using the interaction diagram of Kirsch et al.  $N_f \approx 85$  can be deduced. Evidently, for the system considered here the numerical approach in its present form leads to more favourable results than the other approaches.

Fig. 3 depicts the increase of the maximum pile heave. Up to 10,000 load cycles the pile heave has increased moderately from 11.25mm to 12.3mm. For greater load cycle numbers a greater increase of the accumulation rate is obtained, tending to an infinite rate when the  $N_f$ -value of 28,000 is approached. Therefore, the results coincide with the results shown in Fig. 2.

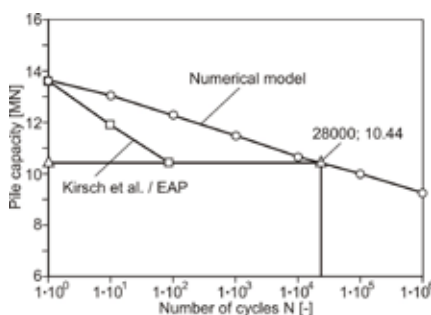

Figure 2: Schematic diagram showing the loading and unloading

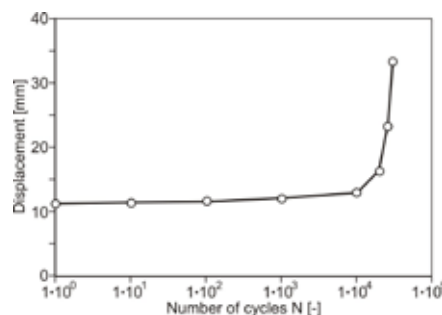

Figure 3: Development of maximum pile heave with number of load cycles for  $X_{\text{mean}}=0.42$  and  $X_{\text{cyc}}=0.34$

## Summary

The presented results show that the proposed method is a promising tool which is capable to derive system-dependent interaction diagrams, and also to calculate  $\Delta R_k$  as well as the increase of the maximum pile heave for a certain cyclic load configuration. With this method it is possible to study the influence of system parameters on the pile behavior under cyclic axial loading. In its present form the numerical model is only a basic model. A further refinement of the method is therefore desirable. Subsequently, a validation of the method by systematic comparison with experimental test results has to be carried out.

## References

- [1] EAP 2012. Empfehlungen des Arbeitskreises „Pfähle“ (EA-Pfähle). Verlag Ernst & Sohn, 2. Auflage (in German).
- [2] Kirsch, F., Richter, T. & Mittag, J. 2011. Zur Verwendung von Interaktionsdiagrammen beim Nachweis axial-zyklisch belasteter Pfähle, Bautechnik 88, Heft 5, 2011 (in German).
- [3] Silver, L. & Seed, B. 1971. Volume Changes in Sands during Cyclic Loading, Proceedings of the American Society of Civil Engineers Vol. 97, No. SM9: pp. 1171-1182.
- [4] Vucetic, M. 1994. Cyclic Threshold Shear Strains in Soils, Journal of Geotechnical Engineering, Vol. 120, No. 12: pp. 2208-2228.

# Cyclic Degradation of Axially Loaded Piles (2014)

Leibniz Universität Hannover,  
Institute for Geotechnical Engineering

Martin Achmus, Katrin Lemke,  
Khalid Abdel-Rahman

## Introduction

Piles used as foundation elements for support structures of offshore wind energy converters are subject to highly cyclic tension or compressive loading. It is known from a number of field and model tests that piles under cyclic axial loading can exhibit a significant reduction of capacity compared to the static loading case. The main reason for this phenomenon is the compaction of the soil adjacent to the pile due to cyclic shearing. From the limited number of tests available, interaction diagrams have been developed. However, such diagrams cannot account for soil conditions or pile geometry and pile stiffness. A generally valid calculation approach for the problem is yet not available.

A special numerical scheme based on a finite element simulation of the pile behavior was developed, which allows calculating the number of load cycles leading to failure for a certain load level. From the first loading and unloading steps, the shear strain amplitude in each soil element is calculated and the expected volume compaction under the considered number of load cycles can be predicted, considering the soil behavior in cyclic simple shear tests. This volume compaction is applied to the finite element model. The result is a stress relaxation and a reduction of the ultimate skin friction acting on the pile. By increasing the soil compaction dependent on the number of loading cycles, the number of load cycles leading to failure for one load combination can be determined. By repeat-

ing this procedure for other load combinations an interaction diagram for one pile-soil-system can be developed.

## Project Description

The idea of the proposed method is to predict the pile behavior under axial cyclic loading and to develop system-dependent interaction diagrams.

The calculations were carried out using the finite element program ABAQUS. A finite element model with 2D-axisymmetric elements was established to investigate the axial pile behavior in sandy soil. A steel pipe pile with an embedded length of  $L=50\text{m}$ , a diameter of  $D=2\text{m}$  and a wall thickness of  $t=3\text{cm}$  in medium dense sand is considered. A linear elastic material behavior of the piles was assumed with the parameters  $E = 2.10 \cdot 10^8 \text{ kN/m}^2$  (Young's modulus) and  $\nu = 0.27$  (Poisson's ratio) for steel. To account for the non-linear soil behavior, elasto-plastic material behavior was assumed for the soil elements. A Mohr-Coulomb failure criterion was considered. A stress dependency of the oedometric stiffness modulus was implemented as well.

To consider the degradation of pile capacity due to a certain number of loading cycles, the system behavior under the first loading and unloading steps is simulated by a finite element calculation. For each soil element the maximum and minimum shear strains  $\gamma_{\max,i}$  and  $\gamma_{\min,i}$  are determined from the principal strain components  $\epsilon_1$ ,  $\epsilon_2$  and  $\epsilon_3$  by

$$\gamma_i = \sqrt{\frac{2}{3}[(\epsilon_1 - \epsilon_2)^2 + (\epsilon_2 - \epsilon_3)^2 + (\epsilon_1 - \epsilon_3)^2]} \quad [3].$$

From the resulting shear strain amplitude  $\gamma_{xy,i} = (\gamma_{\max,i} - \gamma_{\min,i})/2$  in each soil element, the volume compaction to be expected under

the considered number of load cycles is predicted by an approach derived from cyclic simple shear tests reported by Silver & Seed (1971) [1]. By evaluating the results of Silver & Seed (1971), the following equations were derived to analytically describe the volume compaction  $\epsilon_c$  in dependency on the cyclic shear strain  $\gamma_{xy}$ , the relative density  $D_r$  and the number of load cycles  $N$ :

$$\epsilon_c = (10^x - 10^{1.23 \cdot \log N}) \cdot (0.3 + 0.7 \cdot \log N)$$

$$\text{with } \chi(D_r) = 1.71 - 2.82 \cdot D_r + 0.94 \cdot D_r^2$$

Here, the full volume compaction was assumed to occur by horizontal shrinkage of the soil elements, i.e. no vertical strain was applied. Since the soil behaves almost elastic in the range of small strains, no volume compaction is to be expected for shear strain amplitudes smaller than a threshold strain  $\gamma_{\text{lim}}$ . This means that the volume compaction of an element is set to zero if  $\gamma_{xy,i} < \gamma_{\text{lim}}$ . The magnitude of the threshold strain is dependent on the soil type, see e.g. Vucetic (1994) [2]. In the investigations presented here, it is set to  $\gamma_{\text{lim}} = 5 \cdot 10^{-5}$ , which is a typical value for sandy soils.

The volume compaction is applied to the elements in the finite element model for arbitrary numbers of loading cycles and different load levels. The increase of volume compaction leads to a reduction of normal stresses acting on the pile, and thus to a decrease of skin friction and to an increase of vertical pile displacement. The volume compaction is increased gradually in dependency on the number of load cycles until failure occurs. Load cycle numbers up to  $N=1 \cdot 10^{10}$  (or strains coinciding with these cycle numbers, respectively) were investigated. If there is no failure discovered in this range the system is regarded as cyclically stable.

By repeating this process for different values of the mean load and the load amplitude



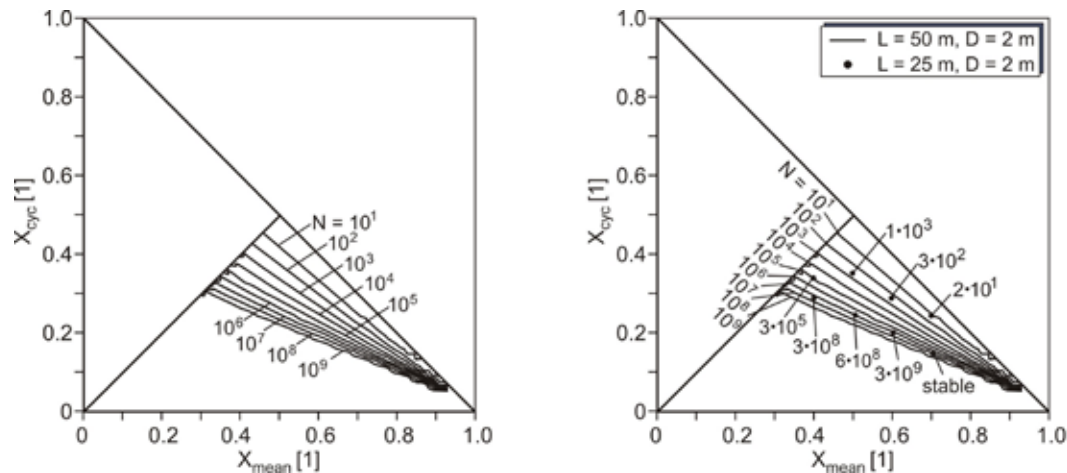

Figure 1: Calculated interaction diagram for a pile with  $D=2\text{m}$ ,  $L=50\text{m}$  in medium dense sand (left), and Interaction diagram for the reference system with additional results for a pile with an embedded length of  $L=25\text{m}$  (right)

an interaction diagram for one pile-soil-system can be established. Based on a series of calculations for 290 different combinations of  $X_{mean}$  and  $X_{cyc}$  an interaction diagram is established by drawing contour lines for specific numbers of load cycles leading to failure.

In the interaction diagram presented in Fig. 1 (left) contour lines for numbers of load cycles leading to failure from  $N=1 \cdot 10^1$  up to  $N=1 \cdot 10^9$  are shown. If a number of load cycles of  $N=1 \cdot 10^{10}$  did not lead to failure the system is regarded as stable. So, for a cyclic loading level in the region below the contour line for  $N=1 \cdot 10^9$  no loss of pile capacity due to cyclic axial loading is to be expected.

The shape of the contour lines is nearly linear in the considered region of one-way cyclic loading in tension. Furthermore it can be stated that the region where the system can be considered as stable is quite large and the distances between the particular lines are relatively small.

As stated before, existing interaction diagrams do not account for pile dimensions or soil conditions. However, the proposed numerical approach now enables a derivation of interaction diagrams for specific pile dimensions and soil conditions. Hence in addition to the reference system a pile with an embedded length of  $L=25\text{m}$  is considered and the results for the two pile-soil-systems are compared. The pile diameter  $D=2\text{m}$ ,

wall thickness  $t=3\text{cm}$  and the soil conditions remain the same, so that just the influence of the pile length can be examined. Again different combinations of the normalized mean load  $X_{mean}$  and load amplitude  $X_{cyc}$  are considered. However, only a few calculations were carried out in order to enable a comparison with the results derived for the reference case. Therefore, in Fig. 1 (right) the results in form of load cycle numbers leading to failure for specific load levels are drawn into the interaction diagram for the reference system.

Based on the conducted calculations it can be stated that there are only slight differences in the results for a pile with a length of  $L=50\text{m}$  and  $L=25\text{m}$ . Especially in the range of lower numbers of load cycles leading to failure the results for the system with the shorter pile accord with the interaction diagram for the reference system. However, in the range of higher load cycle numbers leading to failure differences can be observed in the behavior of the considered systems. The shorter pile shows a slightly more stable behavior under axial cyclic loading than the longer pile.

## Summary

The results show that the proposed method is a promising tool for the derivation of interaction diagrams for piles under cyclic axial loading in sand. It was shown that in general different interaction diagrams apply for different pile dimensions. However, the differences were low for the considered cases of a pile once with  $25\text{m}$  and once with  $50\text{m}$  embedded length.

It has to be pointed out, that the presented numerical approach is still based on several simplifications and assumptions whose impact on the results shall be tested in future works. Subsequently, a validation of the approach by systematic comparison with experimental test results has to be carried out.

## References

- [1] Silver, L. & Seed, B. 1971. Volume Changes in Sands during Cyclic Loading, Proceedings of the American Society of Civil Engineers Vol. 97, No. SM9: 1171-1182.
- [2] Vucetic, M. 1994. Cyclic Threshold Shear Strains in Soils, Journal of Geotechnical Engineering, Vol. 120, No. 12: 2208-2228
- [3] Wegener, D.; Herle, I.: Zur Ermittlung von Scherdehnungen unterhalb von dynamisch belasteten Flächen. Geotechnik, 2010, 33(1), pp. 12-18.

# Large-Size Bolts II – Experimental and Analytical Assessment of the Fatigue Strength of Bolts With Large Dimensions under Consideration of Boundary Layer Effects

Leibniz Universität Hannover  
Institute for Steel Construction

Peter Schaumann, Rasmus Eichstädt

Project Partner (project management)

Technical University Darmstadt  
Institute for Material Science  
Matthias Oechsner, Jörg Beyer,  
Fabian Simonsen

Funding:

Federal Ministry for Economic Affairs and  
Energy (BMWi)

German Federation of Industrial Research  
Associations (AiF)

Research Association for Steel Application  
(FOSTA)

Ref.Nr. IGF-Project No. 486 ZN

Duration: 07/2013 – 06/2015

## Introduction

High-strength bolts sets (HV) are used in support structures for on- and offshore wind turbines as well as other applications of structural engineering. Ring-flange connections between tubular steel tower sections are commonly executed with large-size HV-sets of diameters between M30 and M48. However, increasing sizes of turbines and structures recently led to the application of even larger bolt diameters. Especially at lower connection levels, for instance at the interface between tower and offshore substructures (e.g. jackets or monopiles), design commonly requires bolt diameters M64 or M72.

Due to the dynamic load environment of wind turbines with considerable numbers of load cycles and the high notch effect of the bolt thread, fatigue design of the bolts

is of special importance. In order to reduce the fatigue loads preloading of bolts in ring-flange connections is essential for the structural integrity.

Protection against corrosion of bolts is commonly achieved by hot-dip galvanizing. It has been shown that the zinc coating has an impact on the bolt's fatigue strength [1]. However, due to the high mean loads the experimental prediction of the fatigue strength and the quantification of the boundary layer effect is very demanding for bolts with large diameters. Moreover, until now it remains unclear how the zinc coating mechanically affects the fatigue strength of the bolt.

## Project Description

Within a joint research project of the Institute for Steel Construction, Leibniz University Hannover, and the Institute for Material Science, Technical University Darmstadt, the fatigue behaviour of large-size, high-strength bolts under consideration of boundary layer effects is systematically investigated.

To this end the mechanical phenomena, which lead to the reduced fatigue strength of the bolts caused by the zinc coating, are analyzed. Possible explanations are for instance inferior material characteristics of the boundary layer compared to the bolt's base material or micro cracks in the zinc layer which reach into the surface of the base material. Furthermore, the coating affects friction and other surface characteristic in the contact zone between thread and nut. Thus, the coating has an impact on the local load distribution inside the thread. The overall aim is the identification of the decisive mechanisms and the derivation

of a suitable model for consideration of boundary layer effects in analytical fatigue predictions. Besides detailed metallurgical analyses of boundary layer and base material the investigations comprise an experimental quantification of the boundary layer effect on the fatigue strength of notched specimens.

Additionally, extensive fatigue tests are performed directly on high-strength bolts with large diameters. In order to achieve a realistic stress level, all tests are performed under high mean stress of  $0.7 \cdot R_{p0.2\%}$ , which corresponds to the nominal preload of the bolts according to EC 3. The experimental investigations on high-strength bolts comprise fatigue tests under axial loading on more than 100 bolts of size M36 with different boundary layer configurations.

Experiments with constant amplitudes are conducted in a high-frequency pulsator located in the recently opened Test Centre For Support Structures in Hannover (TTH), cf. Fig. 2. With loading frequencies of more than 50 Hz for the given test set-up, the used test facility allows to apply high load cycle numbers of  $N = 5 \cdot 10^6$  to the specimens in only about 26 h while maintaining the required mean load of 515kN. The results of this test series will be three complete S-N curves for HV-sets M36 with the boundary layer configurations black bolt, normal-temperature hot-dip galvanizing and high-temperature hot-dip galvanizing. Thus, the effect of the zinc coating in the high cycle fatigue regime as well as on the fatigue limit strength of the bolts can be quantified. The result basis will be enhanced by fatigue tests on bolts M36 under variable amplitudes performed in a servo-hydraulic testing machine at TU Darmstadt. The transferability of the results on larger bolt diameters and the influence of the size



Figure 1. Hot-dip galvanized bolts M36 and M64



Figure 2. Test set-up for bolts M36 at the TTH

effect will be evaluated in further experiments on bolts of size M64 with two different boundary layer configurations. In order to enable testing under the required mean load of 1680 kN the tests are performed in a 10 MN servo-hydraulic testing machine at the Leibniz University Hannover. For the first time ever these unique large-scale experiments will provide public available fatigue test data of high-strength bolts larger than M48 and under nominal preload level.

In addition to the direct quantification of the boundary layer effect the test results will be used to verify the applicability of an analytical assessment method based on the notch strain approach, cf. Fig. 3. The analytical fatigue life assessment method, which is developed within the framework of the project, focuses on the inclusion of boundary layer effects and on the predictability of fatigue life under variable amplitudes. Hence, the outcome of the project will be a experimentally validated assessment method which can be used for the fatigue life prediction of galvanized large-size bolt under realistic loading conditions.

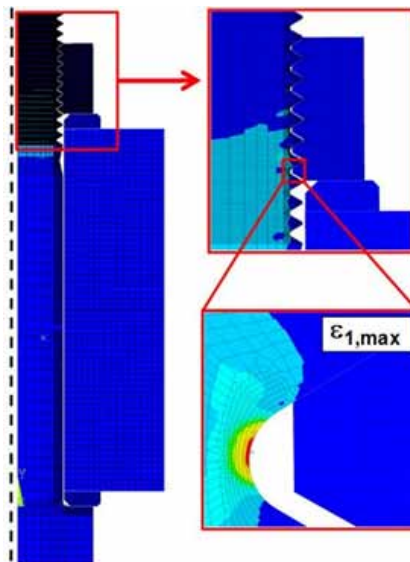

Figure 3. Numerical model for analytical fatigue assessment with the notch strain approach

## Summary

For the connection of different segments of wind turbine support structures bolts with large diameters M30 to M72 are used. Protection against corrosion of the bolts is commonly achieved by hot-dip galvanizing. Until now the effect of the zinc coating on the bolt's fatigue strength has not conclusively been analyzed. Performing extensive experimental investigations, this project will lead to valuable insights in the physical phenomena of fatigue life reduction caused by the galvanization. Based on the results, a secured assessment method for the fatigue strength of large-size bolts which considers the influence of the zinc boundary layer will be developed

## References

- [1] Berger, C., Schaumann, P., Stolle, C., Marten, F. (2008): Fatigue strength of high-strength bolts with large diameters, IGF-Bericht 14728 N. (in German)

# WindBucket – Suction Bucket Foundations as Innovative and Installation Noise Reducing Concept for Offshore Wind Energy Converters

Leibniz Universität Hannover  
Institute for Geotechnical Engineering  
Martin Achmus, Christian Schröder

Institute for Structural Analysis (ISD),  
Raimund Rolfes

Institute for Steel Construction (IfS),  
Peter Schaumann

Institute for Concrete Construction (IfB),  
Ludger Lohaus

Institute for Building Materials Science  
(IfMa),  
Steffen Marx

Partners:  
Fraunhofer Institute for Wind Energy and  
Energy Systems Technology (IWES)  
Firma Overdick GmbH & Co. KG, Hamburg

Funding: Federal Ministry for Economic  
Affairs and Energy (BMWI)  
Ref.Nr. 0325406B

Duration: 06/2012 – 09/2014

## Introduction

Offshore wind energy is one of the most promising technologies in the renewable energy sector. Due to the use of driven piles the installation of current foundation structures is associated with significant noise emissions which sometimes exceed the limits made by the Federal Maritime and Hydrographic Agency (BSH). The installation process of suction bucket foundations is relatively quiet, because no pile driving is required. The suction bucket foundation consists essentially of a steel structure in form of an inverted bucket and its bearing behaviour may be considered as a combination of a gravity foundation and a monopile. Although suction-installed bucket founda-

tions are being used since many years for a wide variety of offshore applications, the suction bucket foundation for the offshore wind energy converters is relatively new.

## Project Description

“WindBucket” is a cooperative project between the University of Hannover (represented by IfB, IGtH, IFMA, IfS, ISD), the engineering company Overdick and the Fraunhofer Institute for Wind Energy and Energy System Technology. In the project the design of the suction bucket foundation for offshore wind turbines is investigated. The overall goal of this project is to assess the feasibility of the application and limitations as well as the development of the guidelines for the planning, design and construction of suction bucket foundations made of steel and reinforced concrete in German offshore areas, in compliance with environmental and economic aspects.

In this cooperative project the structural design with transportation and installation concept is developed based on an ecological and an economic perspective. Installation and operating conditions are examined with particular emphasis on soil-structure interaction. The use of alternative materials and design codes are analyzed. Different numerical models are developed and implemented.

The Institute for Geotechnical Engineering (IGtH) has dealt both with the installation process and the bearing behaviour of buckets. Regarding the installation process, flow net calculations were done to assess the critical suction limits for steel and concrete buckets (see e.g. [1]). The reachable installation depths have then been calculated for different soil conditions which represent the German part of the North Sea. Regarding the bearing behaviour of monopod buckets, a simplified calculation method for the static

bearing capacity of a monopod structure in homogenous soil has been derived out of the results of numerical calculations [2]. Moreover, a numerical model to estimate the cyclic load bearing behaviour of monopod structures has been developed and applied [3]. Its results show that the cyclic behaviour of monopods is similar to monopiles. Finally, regarding the behavior of buckets of multipod structures under tensile loading, a mechanical-hydraulically coupled numerical model for the calculation of the partly drained and undrained pullout capacity of a suction bucket has been developed, and parametric studies have been carried out [4]. The following activities of the IGtH will be the development of a design concept which shall include recommendations of procedure for the required proofs and shall also take the special requirements of the German licensing authority (BSH) into account.

The Institute of Structural Analysis (ISD) has continued on the integrated offshore wind turbine (OWT) simulation considering the before developed soil-structure-interaction (SSI) models describing the mechanical suction bucket behavior under a dynamic load regime. These models have been integrated and compared with each other carrying out a modal analysis and a transient load analysis.

The models for soil-structure-interaction, considering the dynamic stiffness behavior and damping characteristics, have been developed further by integrating precise load-displacement results from extensive finite element simulations by the IGtH.

Computation time for the integrated OWT simulation could be optimized by utilizing model order reduction techniques (component mode synthesis) using reduced flexible bodies within a multibody simulation (MBS). For this the simulation framework FAST (NREL) has been applied.

A more realistic simulation has been set up by having regard to aspects of marine growth, corrosion, scour and accumulated damage due to dynamic loads. By the achievements within this work package a time-efficient and still sufficiently precise simulation could be performed as a basis for future work on OWT substructures and especially with suction bucket foundations.

The Institute for Steel Construction (IfS) investigates the buckling behavior of the suction bucket during installation and operation under consideration of geometrical imperfections. In the first step a numerical model was build up that takes account of the nonlinear stress-strain behavior of the soil. Based on this model several parameter studies are performed on the stress and deformations states of the bucket during installation under several kinds of pre-deformations and penetration depths.

The aim of the work is to develop recommendations for the design and verification of suction buckets based on FEM-analyses. The recommendations will also include knowledge on critical fatigue details.

The Institute of Building Materials Science (IfB) is developing possible alternatives for bucket foundations in concrete and composite materials. The advantages and disadvantages of the respective design alternatives have been identified. The global design concept will be discussed and evaluated taking the manufacturing techniques, transportation and assembly facilities including logistics and manufacturing into consideration. A design concept for a large-scale mono bucket foundation made of high performance concrete with steel interior partitions was developed. The deflection at the top of the bucket is limited by the partition walls. By dividing the inner space of the bucket, these partition walls additionally help to control the steering of the bucket during the installation process. The design concept has been prepared giving due attention to specific features of the components. Investigations on requirements for manufacturing and logistics have revealed that the techniques used in heavyweight offshore foundations can suitably be adopted. The neces-

sary measures for scour protection can be carried out in accordance with heavyweight offshore foundations.

Besides methods of construction such as reinforced and prestressed concrete as well as composite or sandwich construction concepts were considered for alternative large-scale mono bucket foundations. But the preliminary research has revealed no decisive advantage due to the usage of smaller wall thicknesses of composite or sandwich construction concepts. The reinforced concrete and prestressed concrete is chosen for the design of the large-scale mono bucket foundation concept.

The Institute of Concrete Construction (IfMa) has designed a concrete suction bucket foundation. Based on analytical design concepts a basic geometry was developed under consideration of the material properties and the structural behavior of concrete structures. The top has been constructed as a combination of a domed and a conical shape, which proved to be favorable for the load transfer. Due to the construction principals of concrete structures the skirt of the concrete bucket is much thicker than of a steel bucket. Investigations of the Institute for Geotechnical Engineering (IGtH) have shown that the installation is also feasible, but the achievable penetration depth is slightly lower than for a steel bucket.

In a secondary step the basic geometry was examined in numerical investigations by finite element software. The geometry was optimized under consideration of ultimate and serviceability limit states (ULS and SLS). The investigations have shown that concrete suction buckets are a feasible alternative to steel buckets.

In September 2013, a screening workshop was held to discuss the results of the conducted research activities.

## Summary

The goals and activities in the R&D project "WindBucket" are described in this report. The goal of the project is to assess the feasi-

bility of the suction bucket as a foundation for offshore wind energy converters since experiences in this field are still missing. The investigations and the current state of knowledge show that the suction bucket foundation is feasible for German North Sea conditions. Nevertheless the necessity for further research is still evident.

## References

- [1] Achmus, M.: Suction Buckets aus Beton?, in: Festschrift Ludger Lohaus zur Vollendung des sechzigsten Lebensjahres (Hrsg. T. Steinborn), Berichte aus dem Institut für Baustoffe der Leibniz Universität Hannover, Heft 12, 2014.
- [2] Achmus, M.; Akdag, C.T.; Thieken K.: Load-bearing behaviour of suction bucket foundations in sand, Applied Ocean Research 43, 2013, pp. 157-165.
- [3] Achmus, M.; Thieken, K.; Akdag, C.T.; Schröder, C.; Spohn, C.: Load bearing behavior of bucket foundations in sand, Proceedings of the 3rd International Symposium on Computational Geomechanics (Com-Geo III), Krakau, Polen, pp. 586-597.
- [4] Thieken, K.; Achmus, M.; Schröder, C.: On the tensile resistance of suction bucket foundations in sand, Computers & Geotechnics 60 (2014), pp. 88-100.
- [5] Achmus, M.; Schröder, C.: Installation und Tragverhalten von Bucketgründungen für Offshorebauwerke, Bautechnik 91 (2014), Issue 9, Ernst & Sohn Verlag, pp. 597-608.

# GROWup – Grouted Joints for Offshore Wind Energy Converters Under Reversal Axial Loadings and Upscaled Thicknesses

Leibniz Universität Hannover  
Institute for Steel Construction (IfS) –  
project leader  
Institute for Building Materials Science  
(IfB) – project co-leader

Peter Schaumann, Anne Bechtel,  
Alexander Raba (IfS)  
Prof. Ludger Lohaus, Michael Werner (IfB)

Funding: Federal Ministry for Economic  
Affairs and Energy (BMWi)  
Ref.Nr. 0325290

Duration: 06/2011 – 05/2016

## Introduction

Most of the German offshore wind farms (OWFs) in North and Baltic Sea are located in water depths larger than 30 m. With increasing water depths latticed steel support structures like tripods or jackets are installed preferably.

The connection between foundation pile and substructure is realized by a grouted joint. The steel tube of the substructure is placed

inside or outside of the driven steel pile and the annulus is filled with high-performance grout. This grouted connection is used to compensate inclinations or eccentricities from the installation process. Compared to grouted connections in Monopile substructures, the grout annulus in grouted connections of latticed structures is relatively large. As grouted connections in latticed support structures are exposed to high cyclic actions by wind and wave the fatigue design is the main design driver. Due to deficiencies in the design guidelines and in the knowledge for grouted connections with large grout thicknesses, a reliable and economic design is difficult if not impossible. Influences of material specific installation requirements are currently not considered in established offshore design standards.

## Project Description

The research project GROWup focuses on the design and installation of grouted connections in lattice support structures. The fatigue behaviour of tube-to-tube connections is investigated experimentally by using different large grout thicknesses, varied

grout materials and water in large-scale and small-scale tests. Furthermore, pumping techniques of different grout materials under harsh offshore conditions are examined. The combination of all aspects shall lead to a holistic design approach.

Fatigue tests on axially loaded small- and large-scale grouted connections. To investigate a broad range of different filling materials, various loading parameters and the effect of water small-scale grouted connection specimens are used (cf. Fig. 1). These small-scale test specimens being equipped with shear keys were used for static tests to determine the ultimate load capacity FULS. Considering this static capacity fatigue tests with axial pulsating compression load scenario are performed under two different ambient conditions; a dry and a wet environment. In Figure 1 results for the small-scale test specimens are presented, which show that the specimen being fully submerged in a water basin during testing provides a reduced number of endurable load cycles until failure compared to the specimen tested under dry conditions. Further results are presented in [1].

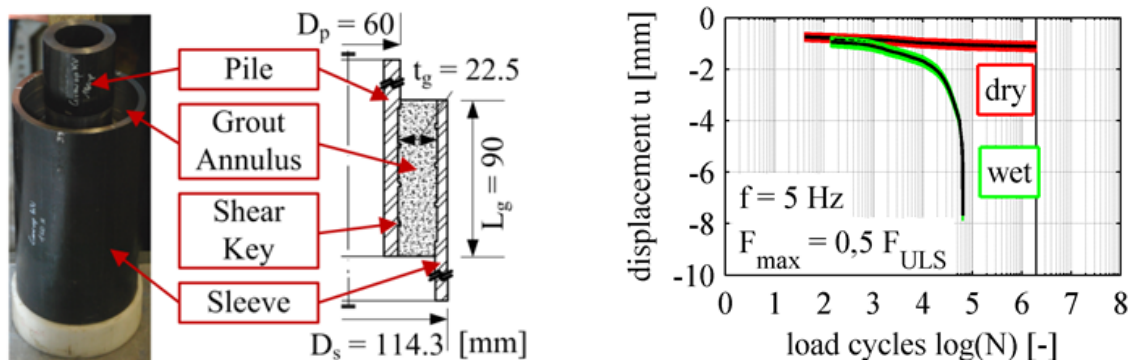

Figure 1: Small-scale test specimen (left) and fatigue test results under dry and wet conditions (right)

In order to quantify the effect of large grout thicknesses to the fatigue behaviour of axially loaded connections large-scale grouted connection tests are conducted. With reference to real jacket and tripod dimensions two test specimens were established in a scale of ~1:2 und ~1:4. The grout layer thickness of test specimen no. 1 is ~80 mm, whereas test specimen no. 2 has a grout layer thickness of ~180mm. The test specimens are equipped with 5 shear keys and filled with two different grout materials.

The test program consists of different load levels revealing a progressive increase of the maximum load and including a fully reversal loading ( $R=-1$ ) followed by a pulsating-compression loading ( $R=\infty$ ). The maximum compression load for the reversal loading is a tension force of 3 MN with an amplitude of 3 MN, whereas the maximum applied compression force is -8 MN during the pulsating compression loading with an amplitude of 4 MN. As all test specimens are exposed to the same test program, the test specimen no. 2 with the same filling material, but with a larger grout thickness of ~180 mm was loaded in a range of 11% to 90% of the static capacity. Fig. 2 depicts the test specimen installed in the testing facility. The opened test specimen no. 1 and 2 showed crossing compression strut cracks caused by tension and compression loads. In addition to these cracks a wedge of crushed grout appears on the load averted side of the pile shear keys. Hence, both specimen



Figure 2:  
Large scale test specimen in testing facility

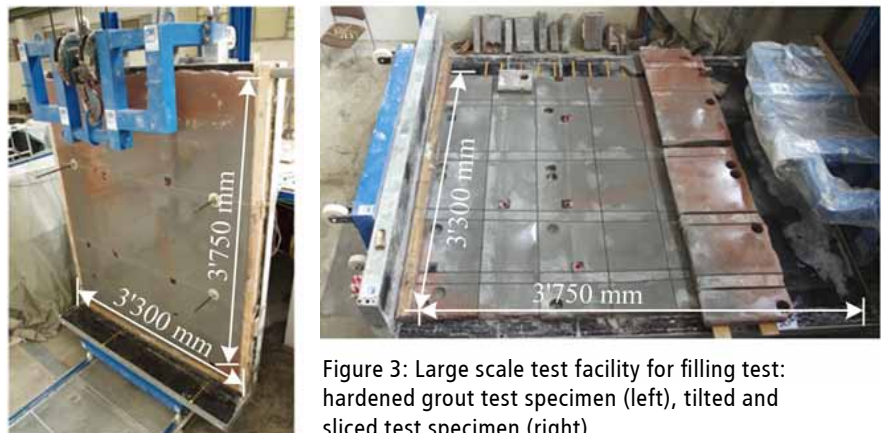

Figure 3: Large scale test facility for filling test: hardened grout test specimen (left), tilted and sliced test specimen (right).

revealed a grout matrix failure. Further investigations and results are presented in [1] and [2].

**Pumping Tests.** Small and large-scale filling tests are performed in the laboratory. The laboratory testing facility for these filling tests was developed and tested as reported in [3]. First results of the filling tests are presented in [4]. These results show a negative influence to the compressive strength of the grout due to the water in the formwork. As a result, the large-scale testing facility was sealed. Fig. 3 shows the testing facility without the front formwork panels after filling untilted (left) and tilted (right) to slice the wall for evaluating occurred sedimentations and to drill cores for evaluating the compressive strength. The first filling test shows that a completed filling of the formwork is possible without large defects in the grout structure. The test was performed with three different grout materials usually used in offshore applications.

## Summary

The BMWi-research project GROWup focuses on the design and installation of grouted connections with large grout thickness in latticed support structures. The fatigue tests of the grouted connections showed first effects induced by the large grout annulus and the fatigue behaviour in wet conditions. Furthermore, the pumping tests demonstrated the behaviour of the material being exposed to different circumstances.

The financial support by the Federal Ministry for Economic Affairs and Energy as well as the support by Fraunhofer IWES, Det Norske Veritas Germanischer Lloyd Group, Senvion SE, RWE Innogy and Strabag Offshore is kindly acknowledged.

## References

- [1] Schaumann, P., Raba, A., Bechtel, A.: Effects of Attrition Due to Water in Cyclically Loaded Grouted Joints, Proceedings of the ASME 33rd International Conference on Ocean, Offshore and Arctic Engineering (OMAE), San Francisco, California, USA, June 08th – 13th, 2014.
- [2] Schaumann, P., Bechtel, A., Lochte-Holtgreven, S.: Grouted Joints for Offshore Wind Turbine Jackets under Full Reversal Axially Loading Conditions, Proceedings of the ISOPE 2013, 30th June – 5th July 2013, Anchorage, United States of America, 2013.
- [3] Lohaus, L.; Werner, M.: In-Situ Assembly (WP 5), Probabilistic Safety Assessment of Off-shore Wind Turbines – Annual Report 2013, Germany, February 2014.
- [4] Werner, M.: Grouted Joints in Offshore-Windenergieanlagen – Materialverhalten hochfester Vergussmörtel bei unplanmäßigen Ereignissen während des Verfüllvorgangs, Proceedings of the 1. DAfStb Jahrestagung 2013, Bochum, Germany, 7th – 8th November 2013.

# HyConCast – Hybrid Substructure of High Strength Concrete and Ductile Iron Castings for Offshore Wind Turbines

Leibniz Universität Hannover  
Institute of Concrete Construction (project management) (IfMa)

Steffen Marx, Christoph von der Haar,  
Marina Stümpel

Institute for Steel Construction (IfS)  
Peter Schaumann, Luka Radulovic  
Franzius-Institute for Hydraulic,  
Estuarine and Coastal Engineering (FI)  
Torsten Schlurmann, Arne Stahlmann,  
Kim Mario Welzel

Partner:  
grbv Ingenieure im Bauwesen GmbH & Co.  
KG (grbv)  
SSF Ingenieure AG (SSF)  
Siempelkamp Giesserei GmbH (SGK)  
Max Bögl (MB)

Funding: Federal Ministry for Economic  
Affairs and Energy (BMWi)  
Project Management Jülich (PTJ)  
Ref.Nr. 0325651

Duration: 01/2014 – 12/2016

## Introduction

Current substructures of offshore wind turbines (OWT) are typically built as steel structures. Compared to steel structures, concrete constructions offer advantages in terms of manufacturing and maintenance costs as well as durability. Therefore, the research project "HyConCast - Hybrid substructure of high strength concrete and ductile iron castings for offshore wind turbines" deals with the development of a novel, hybrid substructure for offshore wind turbines for water depth up to 50 m and outputs of  $\geq 6$  MW.

The overall objective of this project is to assess the feasibility and applicability as well as to investigate the necessary basics for planning, design and construction of a hybrid substructure. Transport and installation concepts will be developed, the risk of

scour on the seabed will be analyzed and the structural behavior of the installed components and connections will be investigated.

## Project Description

The research project is funded by the Federal Ministry of Economic Affairs and Energy. Several institutes of the Leibniz Universität Hannover, several companies and engineering consultants are involved.

The innovative concept of the novel, hybrid substructure bases on combination of large-sized, thin-walled ductile iron casting knots with high-strength, lightweight precast concrete pipes. The relevant design objective is a construction optimally exploit to the properties of the used materials. To ensure high cost efficiency the entire process chain is account from the production of individual components through the inland transport, pre-assembly, the offshore transport, installation, completion up to the operation of the finished support structure.

## Used materials

The mechanical properties of ductile iron, a nodular graphite cast iron material, are similar to steel. However, a significant improvement of this material is the manufacturability and increased corrosion resistance. This material provides large-scale knot structures with wall thicknesses according to the flow of forces and deliver higher fatigue resistance than large scale welded steel components.

The mainly claimed to multi-axial bending knots are connected with low-cost, thin walled concrete precast pipes. In order to their required load bearing capacity the piles are made of high strength (HPC) or ultra-high strength concrete (UHPC) in less stressed areas of the structure. Filled up with normal-strength mass concrete the pipes are maneuvered to its final position, aligned locally and finally lowered.

These knots of ductile iron can be produced in Germany as well as the high strength precast concrete pipes in excellent quality and with own resources in large quantities. Thus, they have an excellent potential for OWT.

## Project course

To achieve the objectives the research project is divided in three work packages (fig. 1: Process diagram).

In the first work package the project partners use their expertise to develop a substructure. The aim is to define the conditions that affect the design of the hybrid substructure in terms of serial production, economy, flexible use and stability. The results of the individual works are collected on the screening workshop and compiled in an optimized version, called base construction (fig. 2) for the following work packages.

In the second work package numerical load simulations and structural studies are carried out on the base structure. Experimental investigations of some small scale test specimen lead to better specifications within the structural design.

In the third work package the examinations concentrate on special areas of the base construction and in particular on their connection elements. For these parts numerical and experimental investigations are planned. In addition to the numeric investigations large-scale experiments will be performed.

## Summary

The objective of this research project is to develop a novel, hybrid substructure. While the first work package is already completed a base structure was determined. With the progress of this project more results will follow and will be presented.



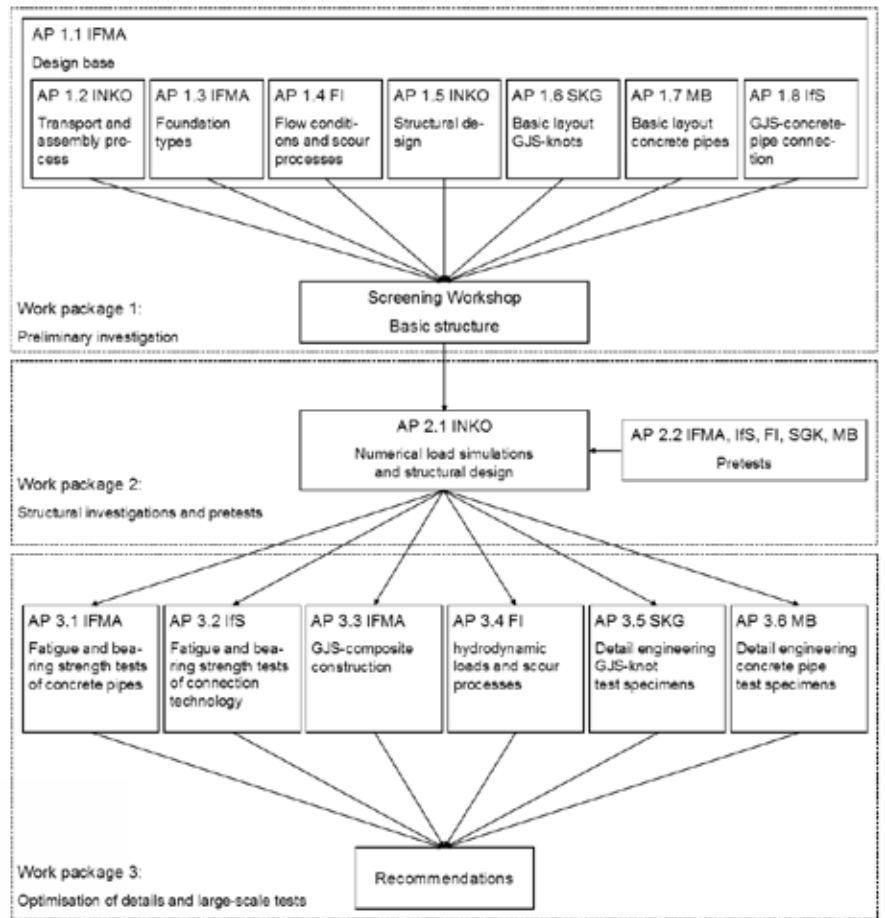

Figure 1: Process diagram

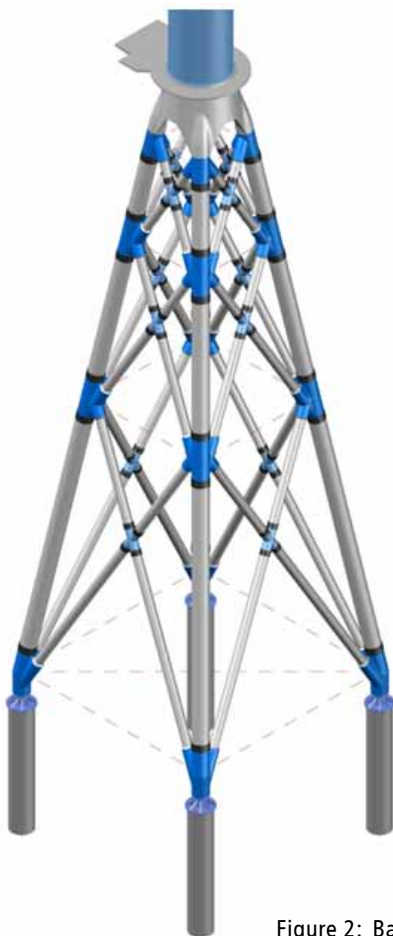

Figure 2: Base construction (© SSF)

References

- [1] <http://www.hyconcast.uni-hannover.de/hyconcast.html> (letzter Zugriff: 02.03.2015)
- [2] Göthel, O. (2014): Forschungsvorhaben HyConCast - Hybride Substruktur aus hochfestem Beton und Sphäroguss für Offshore-Windenergieanlagen, 4. Ingenieurtechnisches Kolloquium des Ingenieurbüros grbv, 18.9.2014, Hannover

# ProBeton – Development and Experimental Testing of Fatigue-Resistant Concrete Foundations for Offshore Wind Turbines

Leibniz Universität Hannover  
Institute of Concrete Construction  
(project management)  
Steffen Marx, Christoph von der Haar,  
Sebastian Schneider

Institute of Building Materials Science  
Ludger Lohaus, Julian Hümme

Partner:  
Ed. Züblin AG – Central Engineering  
Division

Funding:  
Federal Ministry for the Environment,  
Nature Conservation, Building and Nuclear  
Safety (BMUB)  
Ref.Nr. 0325670

Duration: 11/2013 – 11/2015

## Introduction

Current foundations for offshore wind turbines (OWT) are typically built as steel structures. Compared to a steel design, concrete constructions offer advantages in terms of manufacturing and maintenance costs as well as durability. This can be verified by the history of civil engineering structures. For example bridges and tanks are initially built as steel constructions and now mainly built as reinforced and partially prestressed concrete constructions. Even in established offshore areas (e. g. oil and gas rigs) this trend can be observed, in particular with increasing system sizes.

For OWT the fatigue resistance is of great importance. Combined stresses by wind, waves and dynamic structural behavior causes load cycles up to 10<sup>9</sup>. There are no reliable findings on material and structural behavior for this high number of load cycles, especially for concrete under water. The uncertainty in determining the fatigue

resistance significantly affects the economic application of concrete foundation structures for OWT.

## Project Description

The collaborative research project ProBeton is funded by the German Federal Ministry for the Environment, Nature Conservation, Building and Nuclear Safety (BMUB). In this project the focus lays on the fatigue behavior of large concrete foundation structures for OWT. Within ProBeton, typical fatigue loaded construction details like shell connections, changing cross sections and transition structures are investigated.

For the first time large-scale experimental tests and also small-scale tests under offshore-specific conditions are used to investigate the high cycle fatigue bearing capacity. The experimental tests are accompanied by intensively numerical simulations.

A realistic, experimentally verified description of the fatigue behavior of concrete structures for OWT provides two major advantages:

- Concrete foundation structures can be produced much cheaper and more efficient. In deeper water they also occur in competition with conventional steel structures.
- The residual lifespan of existing concrete support structures of wind turbines can be fundamentally re-evaluated. Numerical studies on a gravity foundation, which take into account the redistribution of stresses in the concrete, indicate a multiple of the current design life, cf. [1]. A power production would be possible long beyond the previously defined life time for numerous OWT in the North and Baltic Sea. Existing support structures can

also be used for repowering. For example, existing foundation structures, which make up at least 30% of the installation costs, are used for a more powerful turbine.

A drastic reduction of electricity production costs would be possible for planned and existing offshore wind farms.

## Fatigue behavior of concrete under offshore-specific conditions

A special test rig was built to investigate the influence of different environmental conditions on the fatigue behavior of concrete, cf. fig. 1.

In this test rig small-scale test specimens are tested dry, wet and alternating wet/dry with respect to their fatigue behavior. Due to these experimental tests, SN curves should be derived for high strength concrete under offshore-specific conditions. Furthermore, the influence of fatigue-related damage on the chloride migration is analyzed.

## Experimental component tests

A swinging system is constructed to ensure large stress ranges with high frequencies in large-scale experimental tests. Two unbalance exciters generate dynamic loadings with a frequency nearby the first eigenfrequency of the specimen within the swinging system. In this way, it is possible to investigate even large structural parts or sections effectively in respect to their fatigue behavior. In this process test frequencies up to 25 Hz are possible. The specimens are prepared with strain gauges. These sensors are used to measure the strains and for the controlling of the unbalance exciters via inverters. Using pre-tensioned springs, a basic stress can be applied in the test specimen, cf. fig. 2.



Figure 1: Under water test rig (Foto © Institute of Building Materials Science)

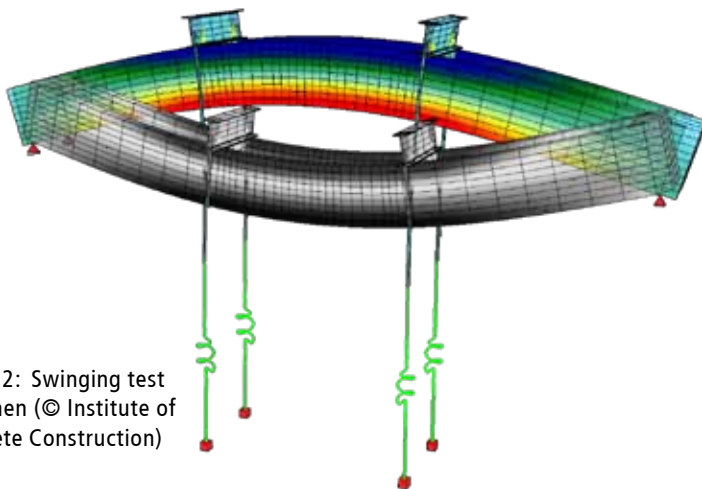

Figure 2: Swinging test specimen (© Institute of Concrete Construction)

In this way different stress levels can be implemented in the investigations. In a previous numerical investigation the most fatigue sensitive areas, the geometry of the test specimen and the arrangement of the measurement sensors are detected.

#### Numeric structural investigations

The obtained knowledge of the experimental tests be used directly within the numerical investigations. They are performed initially on a design of a heavyweight foundation. A realistic damage model has to be found

and implemented in numerical simulations and be validated by the results of the experimental investigations of the fatigue behavior. By adaptive changes in the geometry and dimensions fatigue sensitive areas shall be avoided and uniform stress distributions through the cross-sections are achieved. In addition, the numerical and experimental investigations will be included in the development of an alternative, resolved foundation structure made of high-strength concrete.

#### Summary

Based on previous numerical investigations on wind turbines [2] and small scale experimental tests on high strength concrete specimen [3], this project investigate the fatigue behavior of real structural parts or sections and the influence of environmental conditions (water, chlorides). The findings should be used to optimize concrete foundation structures. The objective target of this project is to describe the fatigue behavior of concrete foundations more realistic and to ensure the economical use of concrete in the field of offshore wind energy.

#### References

- [1] Urban, S.; Strauss, A.; Macho, W.; Bergmeister, K.; Dehlinger, C.; Reiterer, M.: Zyklisch belastete Betonstrukturen, in Bautechnik 89, issue 11, pp. 737-753, Ernst & Sohn (2012)
- [2] Göhlmann, J.: Zur Schädigungsberechnung an Betonkonstruktionen für Windenergieanlagen unter mehrstufiger und mehraxialer Ermüdungsbeanspruchung, Dissertation, Institut für Massivbau, Leibniz Universität Hannover (2009)
- [3] Grünberg, J.; Oneschkow, N.: Gründung von Offshore-Windenergieanlagen aus filigranen Betonkonstruktionen unter besonderer Beobachtung des Ermüdungsverhaltens von hochfestem Beton, Abschlussbericht, Hannover, 2010

# Life Time – Research on Support Structures in the Offshore Test Site alpha ventus – GIGAWIND *life*

Leibniz Universität Hannover  
 Institute of Structural Analysis (ISD)  
 Institute for Steel Construction (IfS)  
 Ludwig-Franzius-Institute for Hydraulic,  
 Estuarine and Coastal Engineering (LuFI)  
 Institute of Building Material Science (IfB)  
 Institute for Geotechnical Engineering (IGtH)  
 Institute of Concrete Construction (IfMa)

Ralf Herrmann (IfMa), Arndt Hildebrandt (LuFI), Boso Schmidt (IfMA), Nikolai Penner (ISD), Raimund Rolfes (ISD), Mahmoud Jahjouh (ISD), Peter Schaumann (IfS), Sebastian Kelma (IfS), Patrick Rzczkowski (IfB), Ludger Lohaus (IfB), Christoph Tomann (IfB), Tobias Schack (IfB), Frederik Stoll (LuFI), Alexander Schendel (LuFI), Alexander Raba (IfS), Karsten Schürmann (IfS), Rasmus Eichstädt (IfS), Andre Stang (IfS), Johannes Albiker (IGtH), Martin Achmus (IGtH), Klaus Thieken (IGtH), Mauricio Terceros (IGtH), Dominik Schäfer (IGtH), Jan Häfele (ISD), Jan Dubois (IfS), Jushua Henneberg (IfS)

Funding: Federal Ministry for Economic Affairs and Energy  
 Ref.Nr. 0325575A

Duration: 02/2013 – 01/2016

## Introduction

Goal of the comprehensive project GIGAWIND *life* is the enhancement of the economic dimensioning concept for offshore wind turbine support structures that has been developed in GIGAWIND alpha ventus by consideration of long-time operation[1]. There are both degradation mechanisms on the resistance side of the environmental surrounded support structure (damages of structure and welds, fatigue, damages of corrosion protection systems, scour, degradation of pile support behavior) and the determination of acting loads from waves and marine growth, which interact with the support structure. The wanted data

of damage and stress at the interfaces will be obtained over a longer timeframe from measurements in the offshore test site alpha ventus by usage of the hitherto developed monitoring methods. This is the requirement to get a scientific perception from the previous investments and to make validated methods and structural models available, which are based on world-wide unique long-time measurements for single studies as well as for holistic offshore support structure design concepts.

## Project Description

The following research projects are part of GIGAWIND *life*:

- Validated methods and structural models for a holistic and economic design of offshore wind turbine support structures (Leibniz Universität Hannover, FKZ 0325575A)
- Condition evaluation and prediction for offshore wind turbines based on measurement data (Fraunhofer Gesellschaft)
- Automated lifetime estimation for tripod support structures considering real loads (Areva Wind GmbH)

Fig. 1 shows the different subprojects.

### Subproject 1: Data Management and Analysis

Up to now, challenges in the field of analysis or monitoring of supporting structures



Figure 1: Overview of subprojects in GIGAWIND *life*

are typically planned and realized as isolated applications. This is time-consuming and normally implies a poor reproducibility and an inadequate data security. Hence, an all-purpose system without the mentioned drawbacks and applicable by persons with little programming skills shall be developed. In this context it is also planned to extend the modeling and simulation tool OneWind by functions for communication with the data management system and for data processing. Thereby, a comparison to simulation data and the validation of numerical results will be possible.

### Subproject 2: Monitoring and Inspection

Based on long-term measurements in alpha ventus appropriate methods are to be developed, capable of identifying condition parameters, damages and loads and to analyze their long-term variation in time. Thereby, essential contributions to the further development of structural models, models for loads, joints (e.g. grouted joints) or corrosion protection systems will be expected. Results from adapted scale tests, performed in TP4, are also needed to prove the applicability and sensitivity of SHM-methods on the basis of realistic damage scenarios. The overall goal of TP2 is to bring knowledge both from improved modeling concepts and sensitive methods for damage detection into practical application and to optimize inspection concepts and time intervals as a basis for the determination of remaining lifetime of wind turbines.

### Subproject 3: Degradation Models

This subproject will provide information and approaches to estimate the remaining lifetime, which exceeds service life. To this end, degradation models including new material properties such as three-dimensional stress state or stiffness reduction due to degradation have to be developed. By implementing these models into existing numerical codes and the subsequent validation with measuring data from *alpha ventus*[2]

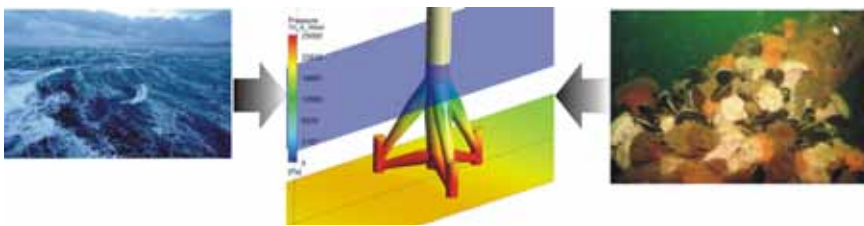

Figure 2: Realistic load scenarios from North Sea typical sea state and marine cover

and from adapted scale tests helps to generate knowledge to enable an overall consideration of different limit states (ULS, SLS, fatigue) for offshore wind turbines.

#### Subproject 4: Adapted Scale Tests

Based on boundary conditions gained from in-situ measurements [3], adapted scale tests serve to optimize mathematical models with respect to realistic environmental conditions of the German North Sea. The overall goal is to meet the requirements of economical serial production. The subproject therefore aims at analyzing the dynamic behavior of the supporting structure and of single components by taking into account the influence of scour and marine cover (see Fig. 2) for a more realistic load scenario as well as stiffness degradation and changes in the cyclic load bearing behavior of piles.

With the application of combined loads in laboratory tests together with the investigation of pre-damaged specimen, a more detailed modeling of corrosion protection systems is to be expected.

#### Subproject 5: Method and Model Integration

The framework of integrated modeling of offshore wind turbines, taking into account relevant degradation processes, offers the possibility to simulate in detail the dynamic load bearing behavior over lifetime. OWTs are designed with aero-hydro-servo-elastic simulation tools taking into account many subsystems and interaction as shown in Fig. 3. Special focus is on the dimensioning of the supporting structure with regard to fatigue, which is often the decisive load case [4]. The measuring data from »alpha ventus« offer an optimum base for the further development of methods and for the validation and calibration of integrated

model approaches. Finally the new developed numerical tools for the fully coupled simulation of offshore wind turbines have the potential to identify load reserves, which can lead to a longer lifetime of the turbines, significantly exceeding service life.

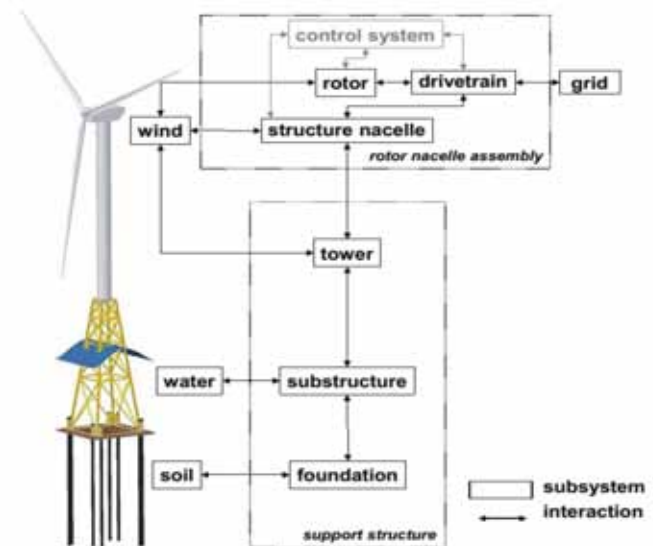

Figure 3: Substructures and interactions in complex models of offshore wind turbines – Source: Wojciech Popko

#### References

- [1] Rolfes, R.; Schaumann, P.; Achmus, M.; Huhn, H.; Lohaus, L.; Schlurmann, T.: Ganzheitliches Dimensionierungskonzept für OWEA-Tragstrukturen anhand von Messungen im Offshore-Testfeld alpha ventus - Abschlussbericht GIGAWIND alpha ventus, Herausgeber: Shaker Verlag. Editor: Rolfes, Raimund and Schaumann, Peter. Address: Aachen. Reihe: ISBN: 978-3-8440-1762-5 (2013)
- [2] Achmus, M., Abdel-Rahman, K.: Design of piles for offshore wind energy foundations with respect to

#### Summary

Since all subprojects are more or less based on the evaluation of large data sets, during the first period in 2013, research in nearly all work packages has been concentrating on the implementation and testing of automated routines for the pre-processing of data. In this context all work packages gathered and defined their requirements related to subproject 1. In subproject 1 the automatic import of measuring data has been implemented and a concept for a relational user database has been developed.

- horizontal loading, ISOPE-2012, The 22nd International Offshore (Ocean) and Polar Engineering Conference; Rhodes, Greece (2012)
- [3] Hildebrandt, A. Schlurmann, T.: Hydrodynamische Belastungsgrößen an Offshore Windenergieanlagen, 9. FZK-Kolloquium – Modellierung im Seebau und Küsteningenieurwesen, FZK, Hannover (2013)
- [4] G. Haake, R. Rolfes, P. Schaumann, H. Huhn, T. Schlurmann, L. Lohaus, M. Achmus (2009): Research on Support Structures in the German Offshore Wind Farm alpha ventus, Journal: Proceedings EWEC 2009, Marseille, 16.-19.03.2009.

# MaRINET – Marine Renewables Infrastructure Network for Emerging Energy Technologies

Leibniz Universität Hannover  
Institute for Steel Construction  
Peter Schaumann, Rasmus Eichstädt

Franzius Institute of Hydraulics, Waterway  
and Coastal Engineering  
Torsten Schlurmann, Mayumi Wilms

Institute of Building Materials Science  
Ludger Lohaus, Niklas Scholle

Institute of Geotechnical Engineering  
Martin Achmus, Khalid Abdel-Rahman

Institute for Structural Dynamics  
Raimund Rolfes, Karsten Schröder

Coastal Research Centre –  
Forschungszentrum Küste (FZK)  
Stefan Schimmels

Funding: European Commission –  
Directorate General for Research &  
Innovation  
7th Framework Program (FP7)  
Ref.Nr. Grant agreement no.: 262552

Duration: 04/2011 – 02/2015

Partners involved in MaRINET consortium:

## Country Organisation

Belgium	1-Tech s.p.r.l.
Brazil	Instituto de Pesquisas Tecnológicas do Estado de São Paulo S.A.
Denmark	Aalborg Universitet
Denmark	Danmarks Tekniske Universitet
France	Ecole Centrale de Nantes
France	Institut Français de Recherche Pour l'Exploitation de la Mer
Germany	Fraunhofer-Gesellschaft zur Förderung der Angewandten Forschung e.V.
Germany	Leibniz Universität Hannover
Germany	Universität Stuttgart
Ireland	University College Cork, National University of Ireland, Cork
Ireland	Sustainable Energy Authority of Ireland
Italy	Università degli Studi di Firenze

Italy	Università degli Studi della Tuscia
Italy	Consiglio Nazionale delle Ricerche
NL	Stichting Tidal Testing Centre
NL	Stichting Energieonderzoek Centrum Nederland
Norway	Sintef Energi AS
Norway	Norges Teknisk- Naturvitenskapelige Universitet NTNU
Portugal	Wave Energy Centre – Centro de Energia das Ondas
Spain	Ente Vasco de la Energia
Spain	Fundación Tecnalia Research & Innovation
UK	National Renewable Energy Centre Ltd.
UK	The University of Exeter
UK	European Marine Energy Centre Ltd
UK	University of Strathclyde
UK	The University of Edinburgh
UK	The Queen's University of Belfast
UK	University of Plymouth

## Project Description

The research project MaRINET, funded by the 7th Framework Program of the European Commission (EC) (Grant agreement no.: 262552), brings together European marine renewable energy test centres in order to advance marine renewables research and development at all scales. In total 28 partners across 11 EU countries and Brazil are working together in order to elaborate standardized test procedures, perform joint research activities and provide free-of-charge international access to high class marine testing facilities for qualified companies and research groups. Even though the marine renewable technologies wave, tidal current and offshore wind energy are all at different stages of development, each technology needs specific research infrastructures to facilitate and catalyze commercialisation. The aim of the project is therefore to streamline testing procedures for each technology and linking together testing facilities at different scales. In order to avoid research duplication and facilitate knowledge transfer, communication and coordination between organisations is improved, leading to a faster development. Furthermore, within the framework of a transnational access program, the EC funding enables companies and research groups from outside the consortium to apply for free entry to MaRINET infrastructure facilities in order to utilize unique testing abilities which do not exist in their home state.

Within the MaRINET consortium five ForWind research institutes participate together with the Coastal Research Centre (Forschungszentrum Küste – FZK) under the head of Leibniz University Hannover. With its expertise in large-scale wave flume tests, the Coastal Research Centre mainly contributes to the collaborative work of the consortium in the fields of wave and tidal current energy. Meanwhile, the ForWind group focuses on research and networking

## Introduction

Offshore renewable energy technologies such as wave energy, tidal current and offshore wind energy are emerging technologies with considerable perspectives for future renewable energy supply. Along the developing path to commercialization these technologies require research to be undertaken at a series of different scales from small-scale models and laboratory investigations through to prototype scales and open sea tests. Within the European Union the full range of high class testing facilities is available but still significant potential for improvement and acceleration of technical development exists in terms of coordination and structuring research activities as well as lowering barriers for cross-border facility access.

activities with respect to offshore wind energy conversion systems. Nevertheless, the infrastructure network provides an excellent opportunity to expand existing know-how in the field of offshore wind energy by knowledge on other maritime technologies on an international level.

In the framework of international networking activities the ForWind group coordinates the subtask on standardisation of offshore wind energy testing practices. In a collaboration of six distinguished European research organisations, investigations on the development of harmonized testing procedures for offshore wind systems are performed. The task aims for identification of applicable instrumentation and data processing methods as well as for the development of scaling factors in order to quantify the full scale offshore performance. With their wide experience in investigations on the full range of structural components and decisive design aspects of offshore wind turbine support structures, the involved ForWind institutes have elaborated recommendations for experimental testing procedures. The work covers the development of experimental testing concepts for foundations un-

der cyclic loading, investigations on scour and scour protection as well as fatigue testing of structural details like bolted joints in offshore wind turbines. Among others, specific attention is directed to the construction of physical models, adoptable instrumentation and data analysis methodology.

In addition to standardisation procedures, the ForWind group is involved in experimental research activities performed jointly with other project partners. In this context experimental investigations are realized in testing facilities in Hannover under responsibility of the involved ForWind institutes. The experiments are planned with the aim to provide further insights in the subjects of displacement measurement systems between pile and sleeve of grouted joints (cf. Figure 1) as well as global structural-health-monitoring methods (SHM) based on acceleration measurements.

For the experiments a small-scale model (~1:50) of an offshore wind turbine is planned which includes tripile foundation, tower and rotor blades. During the planning phase, special attention was given to a realistic mass and stiffness distribution, to the

application of specific damages for validation of the SHM approach and to the application of a down-scaled displacement measuring system for grouted joints. In a first experimental phase investigations are carried out in the laboratory under well defined boundary conditions. During the second stage the model is placed in a wave channel for validation of methods and measurement systems under more realistic boundary conditions, cf. [2].

## Summary

To improve the technical development process of marine renewable energy technologies, such as wave, tidal current and offshore wind energy, coordination and structuring of European research activities is needed. Within the MaRINET project ForWind research institutes participate in a consortium of 28 distinguished international research organisations and ambitiously contribute to the development of harmonized testing procedures as well as joint research activities in the field of structural analysis and monitoring of offshore wind turbine support structures.

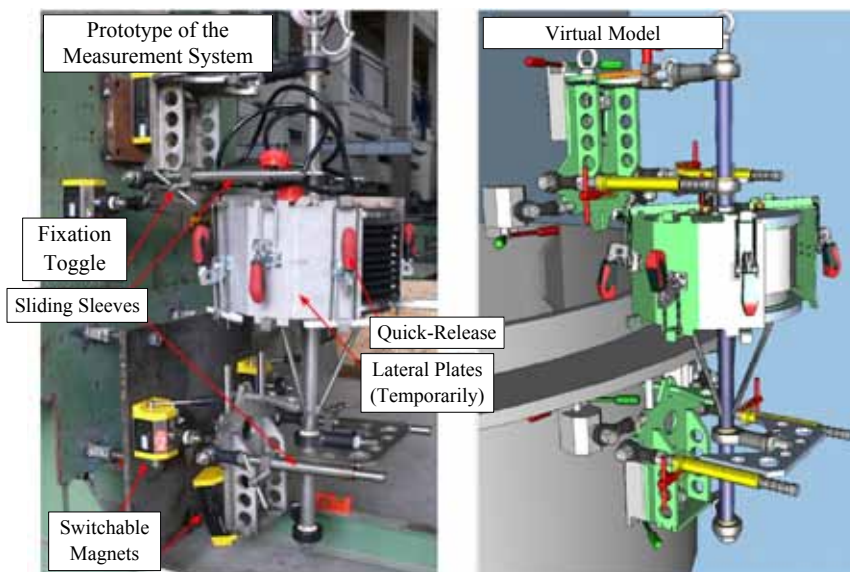

Figure 1: Prototype of the pile-sleeve measurement system tested in the offshore test field alpha ventus (left: test bench, right: virtual model) [1]

## References

- [1] Scholle, N. ; Lohaus, L.: Offshore Measurement System for Relative Displacements of Grouted Joints, Workshop on Civil Structural Health Monitoring (CSHM-4), CSHM-4 Proceedings, Berlin, 2012.
- [2] Rolfes, R.; Huhn, H.; Schaumann, P.; Schlurmann, T.; Lohaus, L.; Achmus, M.: Ganzheitliches Dimensionierungskonzept für OWEA-Tragstrukturen anhand von Messungen im Offshore-Testfeld alpha ventus, Final Report, founded by the Federal Ministry for the Environment, Nature Conservation and Nuclear Safety, support code 0325032, Leibniz Universität Hannover, Hannover, Final Report, 2012.

# MaRINET – Marine Renewables Infrastructure Network

Leibniz Universität Hannover  
Institute of Structural Analysis and Institute of Building Materials Science

Raimund Rolfes, Ludger Lohaus,  
Niklas Scholle, Karsten Schröder

Funding: EC FP7  
Ref.Nr. Grant Agreement No. 262552,  
MaRINET

Duration: 04/11 – 03/15

## Introduction

Due to their bad accessibility in the open sea, visual inspections of offshore wind energy converters (OWECs) cause tremendous efforts for maintenance of the OWECs. To reduce this big effort global structural health monitoring (SHM) systems became part of maintenance strategy of OWEC operating companies. Furthermore, health monitoring is a powerful tool for predictions concerning the actual state and the remaining life time of OWECs. In doing so, it can increase the profitability of wind energy significantly.

## Project Description

Vibration based monitoring is one of the few methods, that is able to determine a structure's damage on a global scale. In his thesis [3], Rytter introduces four levels for damage identification (Determination of damage existence, determination of damage location, quantification of damage, prediction of remaining service life). As stated by [1], vibration based global damage identification methods provide level 1 and level 2 damage identification. According to [2], measurement of damage hot spots is useful to make a statement about damage quantification (Level 3 damage identification). However, this statement is only valid for relatively

small locations where it is measured, which is in contrast to the motivation of collecting damage information of the whole structure. A combination of global SHM methods with monitoring of local hot spots is a new promising approach of a holistic SHM system. To examine and test coupled local-global SHM approaches a scaled model was build. The design of the model is referring to a typical OWEC tripile substructure (see Fig. 1).

The blades and the turbine are simplified by an extra mass applied to the top of the tower. To verify and validate local-global SHM approaches, a possibility to vary the stiffness of local structural components was integrated. To achieve replaceability, structural components with two head plate joints are implemented into the model. By local stiffness modification at point A (see Figure 2) structural damage is simulated. The construction details are shown in Fig. 2.

The bottom of the model is attached to a steel plate and bolted to the floor. The load impulse is initiated by a sudden release of a defined head deflection. Acceleration measurements allocated at three height levels of the tower and at the substructure are used as input parameters for the global SHM analyses. For the local analyses absolute as well as relative displacement data is used. The sensor positions are shown in Figure 1. Test data is recorded in 60 sec duration after load impulse and measuring rate is set to 400 Hz.

The absolute displacements are recorded by laser sensors that are attached to a stand and are adjusted to point at abutments fixed to the model. The relative displacement is recorded by a laser sensor that is attached to the model itself.

The coloured arrows in Figure 2 illustrate the arrangement of the laser sensors. Representative measurement data from a preliminary tentative test of the local displacement sensors have been successfully evaluated. A

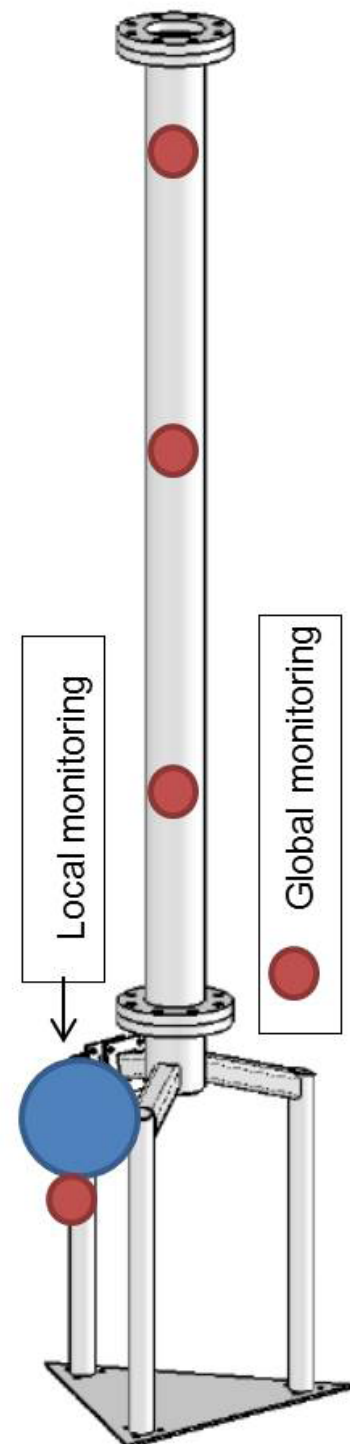

Figure 1: Model and sensor positions



practical implementation of such a measuring task was performed in GIGAWIND alpha ventus and is documented in [4].

System identification is performed using stochastic subspace identification of the acceleration signals. The algorithms used are described in detail [5]. The modal param-

eters extracted by stochastic subspace identification will be used for model updating in further works. Model updating means to fit a numerical model to measured responses of the structure. A numerical model of the structural model will be upset and aligned to the measured modal parameters iteratively.

## Summary

With information of such a coupled SHM system there is a better understanding of the actual state of an OWEC. With measurement data of damage hot spots in combination with global measurements secure statement concerning structural damages of the OWEC can be given. With an SHM system which is able to identify structural damages securely the operator is able to extend the OWEC's expected life time. The OWEC can then be operated until severe damages occur. This life time extension leads to a higher economic efficiency of the OWEC.

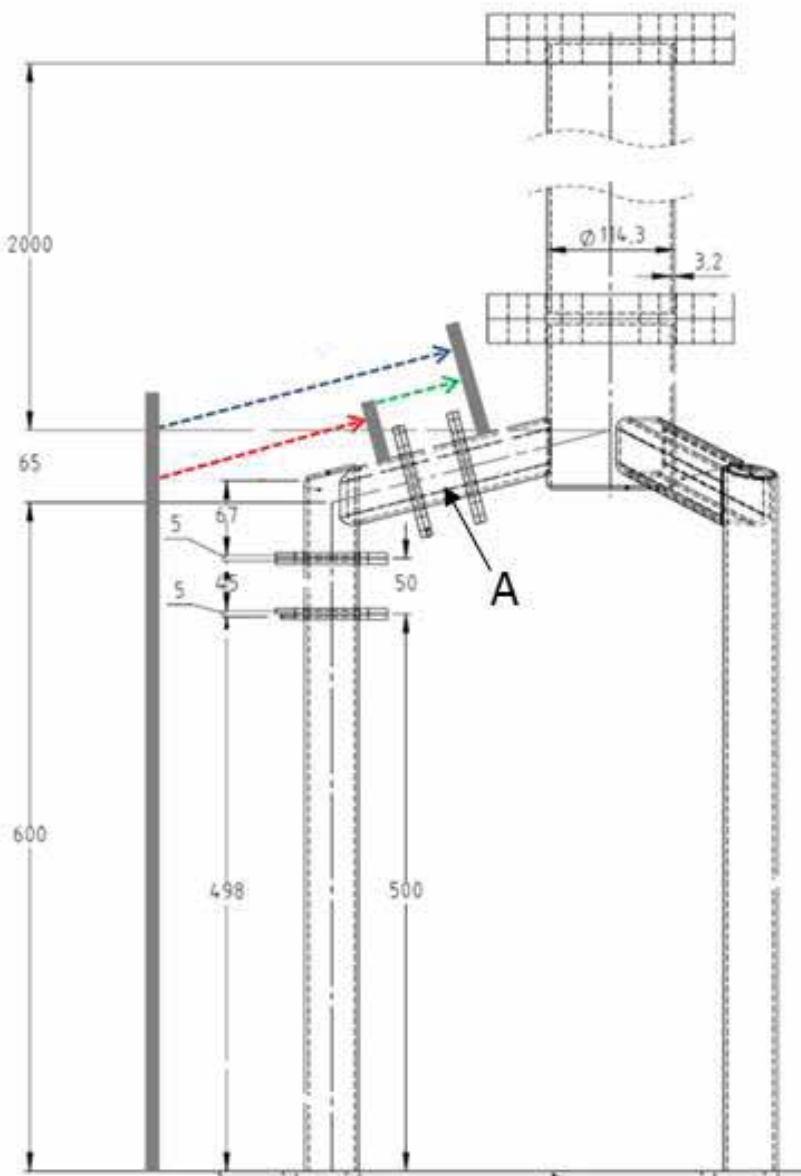

Figure 2: Construction detail of the model

## References

- [1] Doebling, S. W., Farrar, C.R., Prime, M. B.: A summary review of vibration based damage identification methods, *Shock and Vibration Digest* (1998)
- [2] Ciang, C., Lee, J., Bang, H.: Structural health monitoring for a wind turbine system: a review of damage detection methods. *Measurement Science and Technology* (2008)
- [3] Rytter, A. *Vibration based inspection of civil engineering structures*. Aalborg University, Denmark (1993)
- [4] Scholle N.; Lohaus L.: *Offshore Measurement System for Relative Displacements of Grouted Joints*, CSHM-4 Proceedings, Berlin (2012)
- [5] Häckell, M.W., Rolfes, R.: *Monitoring a 5 MW offshore wind energy converter- Condition parameters and triangulation based extraction of modal parameters*. *Mechanical Systems and Signal Processing* (2013)

# INFLOW-Noise

Carl von Ossietzky Universität Oldenburg  
Institute of Physics,  
Research Group Turbulence, Wind Energy  
and Stochastics (TWiSt)

Ingrid Neunaber, Michael Hölling,  
Joachim Peinke

Funding: Federal Ministry for Economic  
Affairs and Energy (BMWi)  
Ref.Nr. 0325459B

Duration: 10/2012 – 09/2016

hofer IWES, the Institute of Aerodynamics  
and Gas Dynamics (IAG) of the University  
of Stuttgart, the Institute for Technical and  
Applied Physics (itap) and GE Wind En-  
ergy, the topic is scrutinized using aero-  
acoustic simulations that are validated by  
wind tunnel experiments. ForWind is in  
charge of the experimental validation of  
the simulation results. The experiments are  
carried out in the wind tunnel of the Uni-  
versity of Oldenburg using an airfoil that  
is equipped with different sensors and an  
external directional microphone array.

## Introduction

The reduction of noise emission of wind  
energy converters (WECs) is important  
to support the acceptance of WECs and to  
fulfill noise regulations when exploiting  
new sites. The most considerable source of  
the noise is the flow-induced noise, i.e. the  
leading and trailing edge noise. The goal of  
the project INFLOW-Noise is to examine  
these noise sources on a WEC airfoil in tur-  
bulent flow. In cooperation with the Fraun-

## Project Description

Focusing on the applicability to wind en-  
ergy, we carry out all experiments in tur-  
bulent flows with atmospheric-like nature, i.e.  
the existence of vortices of different sizes  
as well as a characteristic probabilistic  
distribution of such structures that results  
in turbulence with so-called multi-scale  
properties. For the creation of such flows, a  
fractal grid is used in the experiment. This  
special grid generates flow structures with

the above-mentioned multi-scale behavior.  
To be able to use these wind tunnel exper-  
iments for the validation of simulation  
results, the leading and trailing edge noise  
of the airfoil have to be decomposed from  
the background sound pressure level gener-  
ated by the fractal grid. Therefore, the  
setup was first optimized with regard to the  
background sound pressure level and then  
characterized in terms of the acoustic prop-  
erties as well as the flow properties. For  
the acoustic characterization, the sound  
pressure level of the wind was acquired  
with a single microphone by our project  
partner itap. Two situations have been ex-  
amined: a) *wind tunnel with fractal grid*  
and b) *wind tunnel with fractal grid and  
airfoil ( $AoA=7^\circ$ )* both at a flow velocity of  
50m/s. The result of these tests is shown in  
fig. 1. The leading and trailing edge noise  
are clearly separable from the background  
noise. To describe the flow properties, ve-  
locity measurements were carried out with  
a hot wire anemometer in a volume that  
measures 100cm x 67cm x 130cm behind  
the wind tunnel nozzle. The volume was  
scanned in 10cm x 10cm x 10cm steps

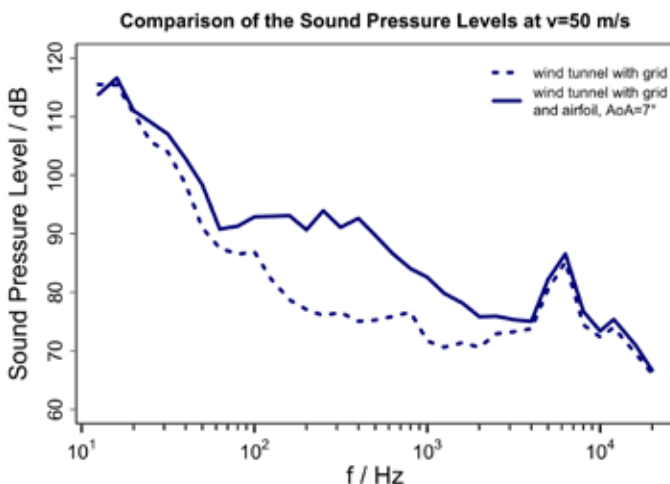

Figure 1: One-third octave frequency spectrum of the final setup with airfoil (continuous) in comparison with the one-third octave frequency spectrum of the final setup without airfoil (dash) at a flow velocity of 50 m/s.

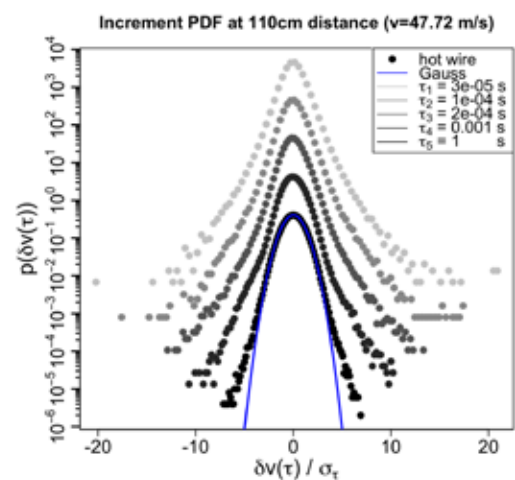

Figure 2:  $p(\delta v(\tau))$  at foil position at 47.72 m/s for different time scales  $\tau$  (grey) in comparison with a Gaussian distribution (blue)

while no airfoil was mounted. Investigation of the flow data shows the existence of atmospheric-like properties in the flow: The multi-scale properties of the generated flows are identified by analyzing the probability density function of velocity increments of the fluctuations (increment PDF). The velocity increment is the difference of two velocity data points with an arbitrary time interval in a time series [1].

In fig. 2, the increment PDFs of the flow at airfoil position are plotted for different time scales in comparison with a Gaussian distribution. The more frequent occurrence of large velocity fluctuations in the measured flow compared with those predicted by a Gaussian distribution can clearly be seen and is characteristic for atmospheric flows. High-frequent pressure fluctuations on the surface of the airfoil are considered to be the main source of the noise. To capture these transient pressure fluctuations, microphones that are capable of measuring high-frequent pressure fluctuations are mounted in a special pattern in the surface of the profile. Measurements were carried out with the profile for different angles of attack in both laminar and turbulent flows. To analyze the fluctuations captured with the microphones, the cross-correlations of sensor pairs are investigated. Fig. 3 b) shows the cross-correlation of microphones

that are aligned in flow direction (for a sketch of the positions, see figure 3 a)). It can be seen that both cross-correlations are of similar shape except for the shifted maximum, which indicates that the time series measured by the sensors are similar with regard to structures like vortices hitting the profile and passing over it. The time lag of the maxima equals the distance of the sensors (cf. fig. 3 a)).

To localize noise sources on the profile, measurements with a directional microphone array provided by the itap were taken. One result is shown in fig. 4, where the profile was mounted with an angle of attack of  $7^\circ$  and the measurements were carried out in turbulent flow with a velocity of 50 m/s. The sources of noise with a third octave frequency of 800 Hz can clearly be identified as located at the leading edge of the profile; they have a sound pressure level in the range of 60dB – 65dB [2].

## Summary

The setup was first optimized regarding the reduction of the sound pressure level within the wind tunnel. With this setup, measurements of the leading and trailing edge noise of an airfoil are possible in the wake of a fractal grid. The multi-

scale turbulence properties of the inflow could be verified. For the examination of the noise development along the profile surface, measurements with a directional microphone array were carried out at different angles of attack for different inflow conditions. Additionally, the profile was equipped with sensors to measure the pressure fluctuations along the airfoil at high temporal resolution.

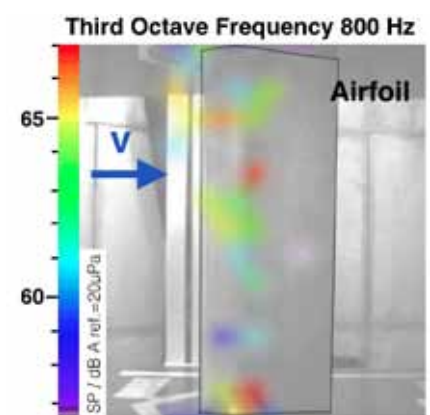

Figure 4: Visualization of the sources of noise with a third octave frequency of 800 Hz on the airfoil in turbulent flow. The sound pressure level of the sources can be taken from the legend. The flow direction is marked with a blue arrow and the flow velocity was 50 m/s.

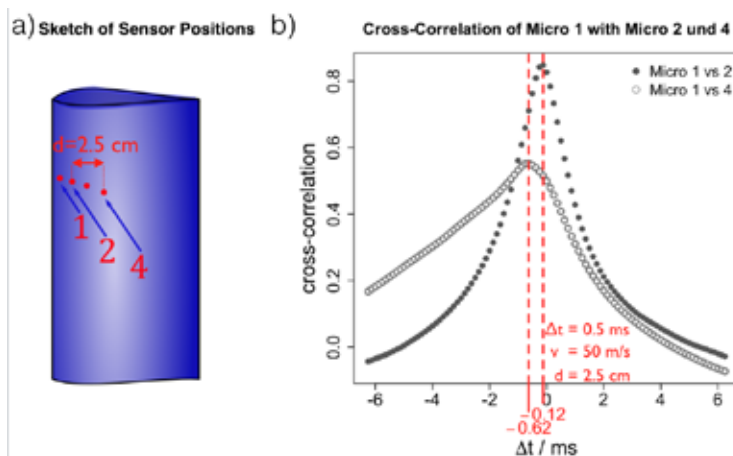

Figure 3: a) Sketch of the positions of the microphones used for the calculation of the presented cross-correlations. b) Cross-correlation of datasets collected with sensors shown in a): Cross-correlation of data of microphone 1 with data of microphone 2 (filled circles) is compared to the cross-correlation of data of microphone 1 with data of microphone 4 (circles); the time lag of the maxima is marked red.

## References

- [1] Wächter, M.; Heißelmann, H.; Hölling, M.; Morales, A.; Milan, P.; Mücke, T.; Peinke, J.; Reinke, N.; Rinn, P.: The turbulent nature of the atmospheric boundary layer and its impact on the wind energy conversion process, *Journal of Turbulence*, Vol. 13, No. 26, p. 1-21 (2012)
- [2] I. Neunaber et al.: Experimentelle Untersuchung des Vorder- und Hinterkantenlärms eines Profils in turbulenter Strömung, lecture at the DAGA 2015 – 41. Deutsche Jahrestagung für Akustik

# Measuring Method for the Aeroacoustic Optimization of Wind Turbine Airfoils

Universität Bremen  
Bremen Institute for Metrology,  
Automation and Quality Science (BIMAQ)

Christoph Dollinger

Funding:  
Funded by the State of Bremen within the  
Applied Environmental Research Program  
(AUF) and the European Regional  
Development Fund EFRE 2007-2013.  
Ref.Nr. FV216A

Duration: 11/2012 – 10/2013

## Introduction

The reduction of noise emissions of wind turbines is accompanied by an increasing efficiency due to the optimized aerodynamic geometry. The noise emission of wind turbines leads to extensive problems for manufacturers as the development site and the approval process are influenced. On this background the industry requires immediately action. Due to legal requirements and acceptance problems of wind turbines in the population, acoustic emissions are a significant issue for manufacturers. Turbulent flow is the main source responsible for the noise emissions. They act as an aerodynamic brake and significantly reduce the potential energy yield. Many wind turbines are planned with technical compromises favoring the reduction of noise emission over power output. The acoustic-aerodynamic optimization of rotor blades could reduce these negative effects of the technical compromises and increase the efficiency.

## Project Description

The objective of the project was the development of a combined measuring method for the acoustic-aerodynamic optimiza-

tion of rotor blades for wind turbines. This method combines thermographic data for turbulence boundary layer analysis with the measurement data of an acoustic camera. Thus, the amplitudes and frequencies of the three-dimensional acoustic emission field can be associated with the geometry of the rotor blade and the inflow-turbulences.

Using the new combined measuring method, selective approaches for modifications of the rotor blades can be developed.

In this way rotor blades can be customized by means of flow elements to reduce turbulences and stall, leading to an increased energy yield of the turbine. Beside the direct environmental advantages of improving the efficiency, the reduction of noise emissions promotes the public acceptance of wind turbines, especially in high populated and urbanized areas. Thus the accessibility of new locations could be supported and the development of wind energy would be pushed. To improve the efficiency and the acoustic characteristics of wind turbines, an acoustic-aerodynamic optimization of rotor blades for wind turbines is required.

Comparable wind turbines in the current 3 MW-class show a relatively large range of sound power levels. The sound power level of these different turbines is in the range from 105 dB(A) to 108 dB(A) (increased sound intensity by 100 %). In contrast to smaller wind turbines, this is comparatively noisy. Because of the technological development and the environmental policy framework, the sizes of wind turbines are increasing continuously. Over the last decade the average rotor diameter of onshore wind turbines increased from approximately 27 m to 82 m. In 2011 a maximum diameter of 126 m was achieved [1]. With increasing rotor diameter, the noise emission increases as well. Furthermore, the relatively wide range of sound power level is an indication for the potential of noise reduction.

The development of wind turbines with less acoustic emissions could open new locations. Furthermore, planned wind parks could be used more efficiently.

The flow tests within the project were conducted at the acoustically optimized wind tunnel of the Deutsche Wind Guard GmbH in Bremerhaven [2]. Laminar air flows at speeds of up to 360 km/h and high Reynolds numbers can be generated in this wind tunnel. Different velocities up to 100 m/s and positive as well as negative angles of attack are adjusted to investigate all possible operating conditions of the rotor blade. The air temperature in the wind tunnel is, due to effects of friction, higher than the temperature of the airfoil-surface. Because of the enhanced exchange of energy by convection in the region of turbulent flow, an increase of the temperature compared to the region with laminar flow can be detected by a thermographic measuring method [3]. Fig. 1 shows the transition between laminar and turbulent flow on the suction side of an airfoil.

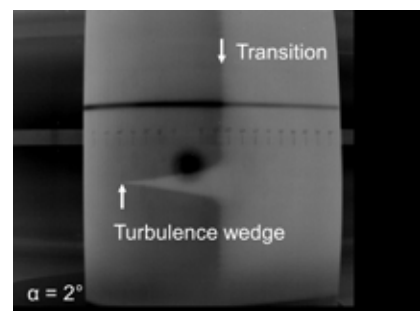

Figure 1: Transition between laminar and turbulent flow on the suction side of an airfoil

Microphone arrays for the acoustic measurements enable a three-dimensional mapping of sound sources in a short measuring time. The noise emissions on wind turbine airfoils is caused by the interaction of upstream atmospheric turbulence with the leading edge of the airfoil and by the interaction between a turbulent boundary layer

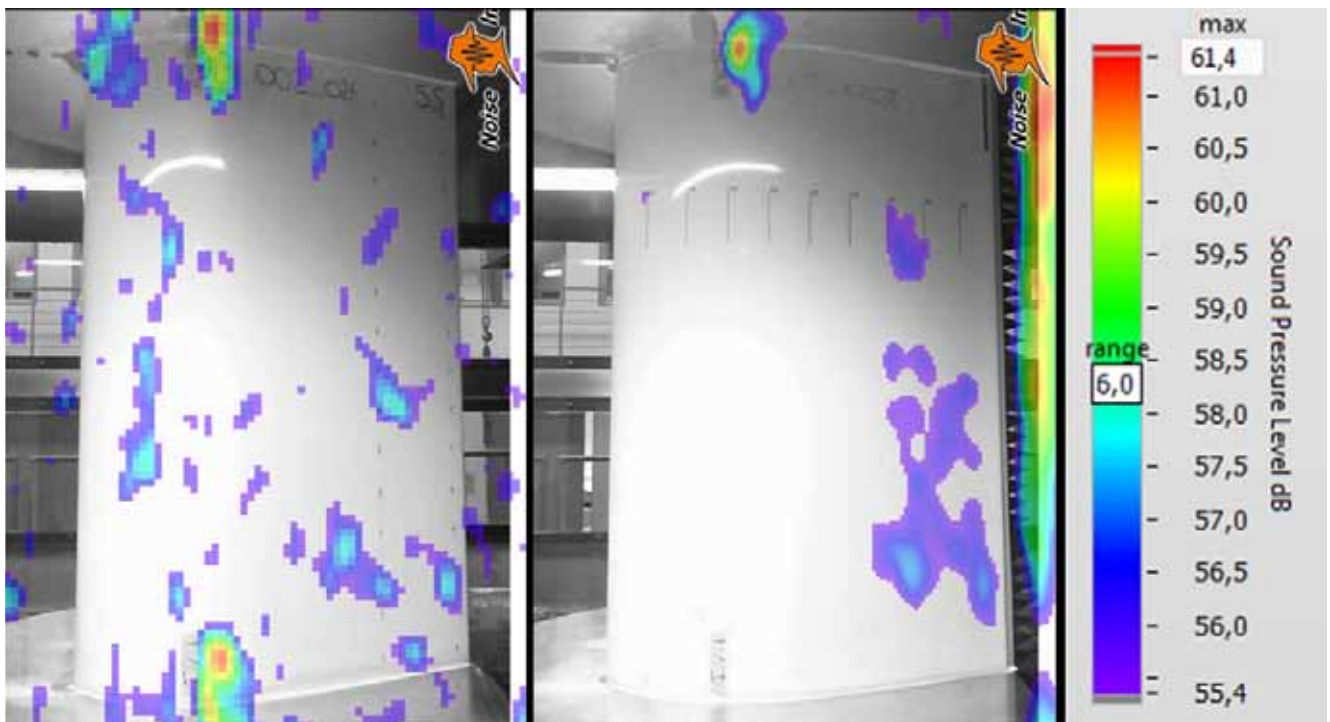

Figure 2: Results of an acoustic measurement at an airfoil

and the trailing edge of the airfoil (trailing edge noise) [4,5]. Turbulent flow, passing the trailing edge of an airfoil, is one of the main airfoil self-noise mechanisms [6]. This trailing edge noise can be tonal or broadband [5].

Fig. 2 shows acoustic measurements on an airfoil evaluated with a standard beam forming algorithm. Measured frequencies are between 2000 Hz and 10000 Hz.

The left side of the figure shows the results for the untreated airfoil. The expected noise sources are the vortex generators at 25% chord on the top and on the bottom of the airfoil. On the right side the same airfoil with an applied serration at the trailing edge is shown.

## Summary

Thermographic and aeroacoustic measurements on airfoils in a wind tunnel provide additional information concerning turbulent boundary transition and trailing edge noise. The thermographic method for

turbulence boundary layer analysis can be used to validate XFOIL and CFD simulations in a wind tunnel test. The position of the transition can be detected without preparing the airfoil for surface pressure measurements. In addition flow control devices as vortex generators or zig zag tape can be checked regarding the func-

tionality. Due to the boundary layer on the tunnel walls, acoustic measurements with a microphone array in a closed test section are a challenging task. Current results show the suitability of the microphone array. Due to structure-borne noise and flow noise, the measurement of trailing edge noise is not satisfactory possible yet.

## References

- [1] Fraunhofer Institut für Windenergie und Energiesystemtechnik (IWES): Windenergie Report Deutschland 2011. 2012, Kassel.
- [2] C. Dollinger, M. Sorg, P. Thiemann: Aeroacoustic Optimization of Wind Turbine Airfoils by Combining Thermographic and Acoustic Measurement Data. DEWI Magazine No. 43, pp. 61-64, 2013.
- [3] M. Malerba, M. Argento, A. Salviuolo, G.L. Rossi: A boundary layer inspection on a wing profile through high resolution thermography and numerical methods. WSEAS Transactions on Fluid Mechanics Volume 3, 2008.
- [4] M. S. Howe: A review of the theory of trailing edge noise. Journal of Sound and Vibration Volume 61, 1978.
- [5] S. Oerlemans, P. Sijtsma, B. Méndez López: Location and quantification of noise sources on a wind turbine. Journal of Sound and Vibration 299. 2007.
- [6] T. Geyer, E. Sarradj, C. Fritzsche: Measurement of the noise generation at the trailing edge of porous airfoils. Experiments in fluids Volume 48. 2010

# Laser-based Contact Pattern Analysis

Universität Bremen  
 Bremen Institute for Metrology,  
 Automation and Quality Science (BIMAQ)

Helmut Prekel, Gert Goch, Robin Lipinski

Funding:  
 German Research Foundation (DFG)  
 Ref.Nr. GO554/32.1

Duration: 06/2013 – 08/2014

## Introduction

The contact pattern analysis is important because it shows whether or not the mutual alignment of gear wheels is correct [1]. At misaligned gear wheels, individual teeth can break and destroy the complete gear, resulting in high costs especially for wind turbines.

Usually the “paste method” is applied to inspect the gear wheel alignment [2]. This method, however, has several disadvantages: It often takes several hours to test a pair of gear wheels and requires a considerable amount of manual work. Furthermore, it does not produce the contact pattern of two individual gear teeth. This project investigates a possible alternative method, which is based on heating up individual gear teeth surfaces by radiation energy, transferring a part of this heat to the counter gear flanks by meshing and detecting the transferred heat of the second gear by thermography [3]. The feasibility of this concept is examined using the Finite Elements Method (FEM).

## Project Description

The project required to find a software strategy and a model-geometry compatible with the capabilities of the available FEM-Software (FlexPDE). Fig. 1 shows a model

geometry for a gearwheel tooth. The heat sink represents the center of the wheel. The meshing of two gear teeth was simulated by two model geometries in contact with a moving contact area (Fig. 2). The simulated measurement process consists of four phases (Fig. 3): In phase I one flank of tooth A is heated up by laser radiation. Phase II: The heat will propagate only within tooth A until short before the contact begins. Up to this point, tooth B is inactive and will remain at ambient temperature. During Phase III the heat transfer takes place by meshing of the teeth, modeled by a moving heat transfer zone. After the contact, a certain time will pass until the contacted flank of tooth B will be visible for an infrared camera. During this time, heat propagates in booth teeth (Phase IV). The simulated teeth flank area was about 20 mm x 50 mm (height x width) and the absorbed laser intensity about 106 Wm<sup>-2</sup>. The phases required approximately 15.5 % (I), 7.7 % (II), 3.9 % (III) and 7.7 % (IV) of one complete rotation (100 %) of one complete rotation (100 %). The complete simulated measurement process is illustrated by Fig. 4.

During phase III, the moving contact zone "paints" heat onto the flank of tooth B, the whole "painted" area should represent the desired contact pattern. It is obvious that the visibility of the contact pattern on a thermographic image will improve the more heat is transferred. On the other hand, the heat propagation in phase IV will wash out the pattern and reduce the contrast.

Several FEM-calculations were performed to analyze these effects. Fig. 5 shows four thermographic images calculated for different rotation times (a: 2.57 s, b: 5.14 s, c: 12.85 s, d: 25.7 s) (note: within each image, the area left of the broken line belongs to the tooth flank, the area on the right belongs to the heat sink; the contact patterns are illustrated by a rectangle). Increasing the rotation time means that more time is available for heating up tooth A and transferring heat



Figure 1: Model geometry of a tooth with a heat sink which presents the center of the gear wheel

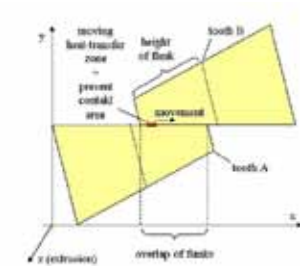

Figure 2: Simulation of the heat transfer during the meshing of two teeth

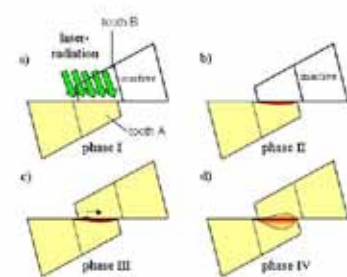

Figure 3: Four phases of the simulated contact pattern analysis

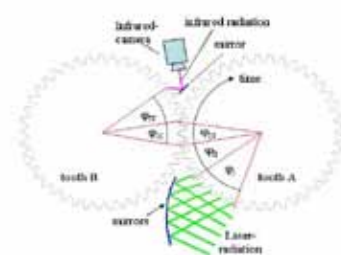

Figure 4: Illustration of the measurement process

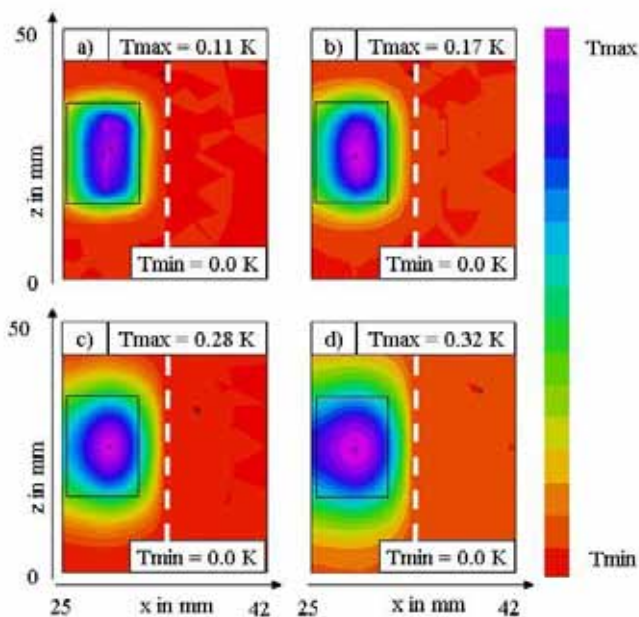

Figure 5: Calculated thermographic images for different rotation times

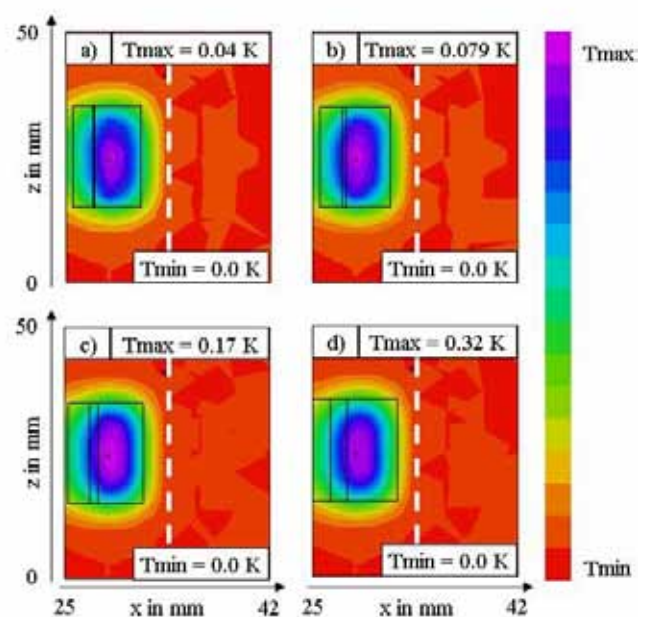

Figure 6: Calculated thermographic images for different widths in x-direction of the present contact area

to tooth B, hence the temperatures on the flank of tooth B increase, too. The temperature increase within the contact pattern in Fig. 5 a (30 mK to 110 mK) should be enough to be detected by modern infrared cameras. More temperature increase is observed in Figures 5 b to 5 d. However, the heat propagation causes the heated area to become much larger than the contact area. Another parameter that influences the amount of transferred heat is the size of the present contact area, which depends on the tooth geometry, hardness and pressure between the teeth flanks. In Fig. 6, the width of the present contact area in x-direction is varied (a: 0.4 mm, b: 0.8 mm, c: 1.75 mm, d: 3.5 mm) at a rotation time of 5.14 seconds. The present contact area is illustrated by a smaller rectangle within the contact pattern area. It shows that a larger contact area obviously does not significantly reduce the contrast of the thermographic images, but increases the temperature and by this improves the detectability of the contact pattern.

The research project is still in progress, the influence of further parameters will be

examined. In addition, calculations using artificial neural networks will be applied in order to attempt to reconstruct the contact pattern from washed-out thermographic images (see Fig. 5d).

## Summary

The project investigates a laser based thermographic approach as a new method for the contact pattern analysis of gear wheels. A model geometry and a software strategy were created and parameter study was performed using commercial FEM software. It shows that the amount of heat that can be transferred from one to another tooth flank is sufficient for a thermographic detection and that the image contrast is high if the time between contact and detection is short. The results are encouraging and prove that the new method has the potential to add a new inspection method for the alignment of gear wheels.

## References

- [1] Goch, G.: Verzahnungsmesstechnik – unverzichtbarer Bestandteil einer Schlüsseltechnologie. Gear Metrology – an Essential Element of a Key Technology. VDI/VDE-Fachtagung Verzahnungsmesstechnik, Stuttgart, VDI-Berichte 1880, pp 1-23, (2005).
- [2] Goebbelet, J.: Tragbildprüfung von Zahnradgetrieben – eine Methode zur Qualitätsbeurteilung. Dissertation, Aachen, (1980).
- [3] Prekel, H.; Gafsi, H.; Goch, G.: Verfahren und Vorrichtung zur schnellen Tragbildanalyse. Deutsches Patent- und Markenamt, Offenlegungsschrift E102012003814A1, (2013).

# Optical Field Measurements of Rotor Blade Deformations

Leibniz Universität Hannover  
Institute of Turbomachinery and Fluid  
Dynamics

Jan Winstroth, Jörg Seume

Carl von Ossietzky Universität Oldenburg  
Institute of Physics

Hauke Beck, Martin Kühn

Funding: Ministry for Science and Culture  
of Lower Saxony (MWK)  
Ref.Nr. 74ZN988

Duration: 12/2011 – 12/2014

## Introduction

The rated power of a wind turbine is proportional to the rotor diameter. Over the last 30 years, commercial wind turbines have evolved from approximately 10m rotor diameter and a rated power of 50 kW, into today's multi-megawatt class with rotor diameters exceeding 150m and rated power of well above 6MW. This development has produced light, slender, and flexible structures, for which the aeroelastic turbine characteristics have become increasingly important to fatigue strength and overall performance. Sophisticated design tools, which have been calibrated and validated against experimental data, are needed in order to optimize energy production, to ensure a long life time, low maintenance costs, and high operational reliability and safety. However, experimental data from full-scale wind turbines often focuses on the integral moments and forces captured during certification measurements. Detailed blade deformation measurements are rare and quite hard to gather because of the large scales involved. Recent advances in digital camera technology have made optical techniques an interesting and prom-

ising tool for small-scale and full-scale wind-turbine testing. The present project will demonstrate the capabilities of Digital Image Correlation (DIC) for measuring 3D rotor blade deformations and vibrations on a multi-megawatt class wind turbine during operation and quantify the accuracy of the optical technique.

## Project Description

The project is subdivided into two major parts. The first project phase consists of preliminary tests to demonstrate feasibility. In detail, a model test bench of a wind turbine is designed, implemented and fitted with the necessary optical equipment for DIC. The test bench is equipped with a three-bladed rotor without profiling which is propelled by an electric servodrive. Fig. 1 shows a picture of the test bench inside the laboratory. Deflection of the blades is achieved by external actuation. The focus is on the flapwise and torsion mode of the rotor blades. One blade of the model turbine is instrumented with resistance strain gauges to validate the results obtained by DIC measurements. The key elements for the first stage of the project are:

- dynamic deformation measurement in a rotating system
- modal analysis and system identification

with DIC on a wind turbine model test bench. Another crucial part during the first phase of the project is the simulation of the field experiment. This part requires a full scale wind turbine to be modeled inside a 3D modeling software. By applying textures of a random dot pattern on the pressure side of the modeled rotor blades, the synthetically generated picture of the wind turbine can be evaluated using DIC. After evaluation with DIC, 3D point clouds (approximately 10,000 data points) are available for each area. However, DIC is not

limited small areas. Covering an entire rotor with a random black-and-white speckle pattern is definitely possible if the entire rotor is of interest.

Based on the knowledge and experience gained during the first phase of the project, the new optical measurement system will be further developed and tested with regard to wind turbine applications in the second phase of the project. In order to demonstrate feasibility, a full scale wind turbine will be equipped with four areas of random dot pattern on one of the rotor blades. The objective is to measure the dynamic deformation and deflection of a rotor blade from a ground fixed position. For this project, the cameras will be focused on the whole rotor and the aim is to track one blade for a complete rotation of the rotor. All operational parameters of the wind turbine will be recorded and synchronized with the DIC measurements. In order to measure the incoming turbulent wind field in front of the rotor, a LiDAR system (Light Detecting and Ranging) will be used. By correlating the data from DIC and LiDAR it is possible to gain a deep insight into the interaction between rotor and wind. In addition the results of this study can be used to validate numerical software tools for aerodynamic and aeroelastic simulations of wind turbines.

## Summary

The project is a proof of principle study to show that DIC has a lot of potential for application on wind turbines. As soon as feasibility has been demonstrated and results are validated, the technique can provide better insight in the interaction of incoming turbulent wind and blade deflection/deformation. The results obtained from DIC can provide a basis for validation and improvement of numerical models. Other scenarios of application are also imaginable. For example, condition monitoring during operation can



save a lot of money when failures caused by material fatigue are detected in an early stage.

This project is currently reaching the end of the second project phase. The proof of principle study on a 3.2 MW wind turbine was successfully completed in 11/2013. With the new optical measurement system it is possible to continuously track rotor blade deformations for up to 15 minutes with a

sampling frequency of 30 Hz. The error estimation for the field test on a 3.2 MW wind turbine suggests that relative out-of-plane bending of the rotor blades can be measured with an accuracy of  $\pm 9.1$  mm, relative in-plane bending of the rotor blades can be measured with an accuracy of  $\pm 10.2$  mm, and relative blade torsion can be measured with an accuracy of  $\pm 0.07$  deg. Three more field tests on even larger wind turbines are scheduled for the near future.



Figure 1: Field test for measuring rotor blade deformations with new optical measurement system



Figure 2: One of two measurement setups for stereo photogrammetry measurements

# Thermographic Boundary Layer Visualization of Wind Turbine Rotor Blades in Operation

Universität Bremen  
Bremen Institute for Metrology,  
Automation and Quality Science (BIMAQ)

Christoph Dollinger

Funding:  
Industrial research  
Ref.Nr. –

Duration: 01/2012 – open-ended

## Introduction

The described method for thermographic boundary layer visualization of wind turbine rotor blades in operation uses a thermographic measurement system, which detects the temperature distribution on the rotor blade surface. In operational mode the boundary layer near the leading edge is laminar. At some point on the profile it turns into a turbulent boundary layer. This point is called laminar-turbulent transition (Fig. 1).

The turbulence boundary layer analysis with a thermographic system is based on the heat exchange by convection, conduction and radiation between the rotor blade and the surrounding flow. The surface temperature is influenced by a variety of parameters and can be correlated to the air flow. The method can either be used in a wind tunnel, or at a running wind turbine, or in any system in which a flow induced surface temperature gradient is present. Former measurements at the Deutsche WindGuard's aeroacoustic wind tunnel in Bremerhaven, Germany, show a good agreement with simulation data [1].

Comparing design and operational transition locations can help turbine manufacturers improve their performance prediction models and better understand the differences in performance between similar turbines.



Figure 1: Boundary layer on a rotor blade profile (Computational Fluid Dynamics Simulation)

## Project Description

Knowing the position of the transition between laminar and turbulent flow can be used in the design of new rotor blades [2] and in flow control by flow control add-ons (e.g. vortex generators) [2, 3]. The location of the transition has a direct effect on the drag of a rotor blade. The turbulent boundary layer located behind the transition is associated with a higher skin friction than the laminar boundary layer in front of the transition. Approximately 10 % more laminar flow region results in a 10 % lower drag-coefficient.

In the case of wind turbines, best results are obtained when the sun is heating the rotor blade surface. Under these circumstances the temperature on the laminar flow region is higher than on the turbulent flow region. Measuring the temperature distribution permits detecting the boundary layer condition on the rotor blade indirectly.

Rotor blade tip speeds of 75 m/s require fast shutter speeds (short integration times) to reduce motion blur. A high speed actively cooled 640 x 512 pixels InSb-focal-plane-array with a thermal resolution better than 0.025 K is used together with a telephoto lens to acquire high resolution thermal images of rotor blades in operation. In this specific case, a 100 mm focal length telephoto lens with a 2.0x extension was used (Fig. 2).

Due to the mobile thermographic system, measurements can be performed at every accessible position around the observed wind turbine. The distance between wind turbine and measurement position during the measurements can be up to several hundred meters. The position is only limited by the off-road ability of the vehicle for the power supply.

Measurements on running wind turbines indicate a high potential for a flow visualization during operation. The temperature

gradient between laminar and turbulent flow correlates with the temperature offset between the air temperature and the temperature on the rotor blades heated by the sun. The laminar-turbulent transition and laminar flow regions are visible on the resulting images. The reduced field of view requires stitching several images to obtain a single image of one rotor blade.

Leading edge contamination and erosion, resulting in turbulence wedges, can reduce the extent of the laminar region or make it disappear altogether. Turbulence wedges, which begin at locations other than the leading edge region, are most probably imperfections or damages on the rotor blade surface, and should be investigated.

Fig. 3 shows the thermographic images of all blades of the Senvion 3.4M104 research wind turbine. The measurements were taken on the suction side in a distance of approximately 400 m. Additional result regarding different turbines and wind shear effects can be found in [4, 5].

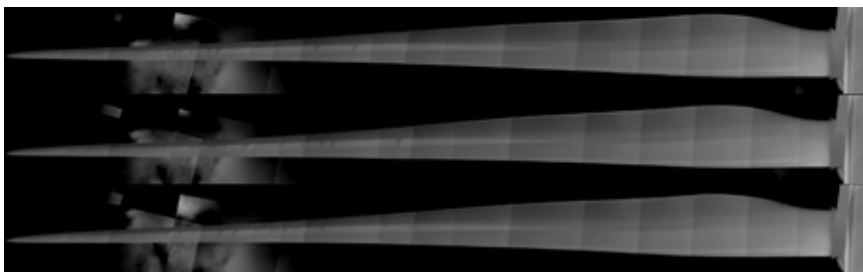

Figure 2: Thermographic imaging system with telephoto lens.

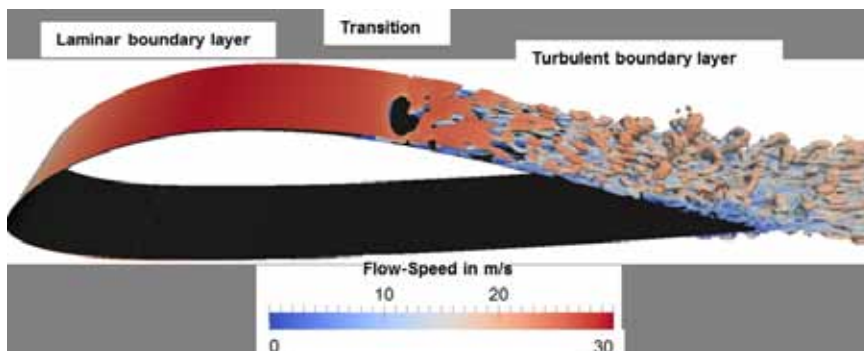

Figure 3: Measurements on the research wind turbine Senvion 3.4M104 of the University of Bremen. Suction side of all blades

## Summary

Measurements provide information concerning laminar-turbulent boundary layer transition. The method, which requires no preparation of the rotor blades, permits verifying predictions and evaluating operational conditions, such as areas with an early laminar-turbulent transition due to leading edge contamination, erosion, manufacturing irregularities or the effects of leading edge protection on the transition location. The laminar regions can be additionally compared between blades and blade positions, in order to further analyze effects like wind shear and tower influence. Missing flow control add-ons, such as vortex generators or zig-zag tape sections are also clearly noticeable.

Future investigations will concern the simultaneously measured geometry of the rotor blade with respect to the pitch and azimuth angles in relation to the measuring position. Thus the laminar-turbulent boundary transition location can be deter-

mined locally (at every radial position) with respect to the chord-wise position, in order to deliver  $X_{tr}/c$  as a function of  $r$  for all blades. It is planned to improve the data acquisition and to develop image processing algorithm for the automated detection and documentation of the chord-wise transition location, the percentage of laminar flow, damages on the surface and other aerodynamic irregularities.

Other potential applications include the comparison of the transition location depending on the inflow conditions (i.e. the turbine operating behind another turbine), and long term follow up to analyze soiling, erosion and seasonal effects.

## References

- [1] Dollinger, C; Sorg M.; Thiemann, P.: Aeroacoustic Optimization of Wind Turbine Airfoils by Combining Thermographic and Acoustic Measurement Data. DEWI Magazine No. 43, pp. 61-64, 2013.
- [2] Bæk, P.; Fuglsang, P.: Experimental Detection of Transition on Wind Turbine Airfoils. Proceedings of EWECEuropean Wind Energy Conference and Exhibition EWECE, 2009.
- [3] Součková, N.; Kuklová, J.; Popelka, L.; Matějka, M.: Infrared Thermography as a Visualization Tool of Flow Control by Vortex Generators. Colloquium Fluid Dynamics 2010.
- [4] Dollinger, C.; Balaesque, N.; Sorg, M.: Thermographic Boundary Layer Visualisation of Wind Turbine Rotorblades in Operation. EWECEurope's Premier Wind Energy Event 2014, Barcelona, 2014.
- [5] Dollinger, C.; Balaesque, N.; Sorg, M.; Goch, G.: Thermographic Measurement Method For Turbulence Boundary Layer Analysis On Wind Turbine Airfoils. AWEA Wind Power 2014 Conference and Exhibition, Las Vegas, 2014.

# Model Wind Turbines for Experimental Studies

Carl von Ossietzky Universität Oldenburg  
Institute of Physics,  
Research Group Turbulence, Wind Energy  
and Stochastics (TWiSt)

Jannik Schottler, Agnieszka Hölling,  
Michael Hölling, Joachim Peinke

Funding: Ministry for Science and Culture  
in Lower Saxony (MWK)  
Ref.Nr. ZN2547

Duration: 12/2009 – 11/2014

## Introduction

Nowadays, the majority of wind turbines is installed in clusters of multiple turbines, namely wind farms. Since the layout of a wind farm is designed in order to achieve an economical optimum, the spacing between the turbines is finite, typically around 7 rotor diameters [1], depending on the site. Due to the changing wind directions, fluid mechanical interactions of the individual turbines are inevitable. The flow behind a wind turbine is called wake, which potentially affects the performance of a turbine operating further downstream. Numerous studies showed that wake effects significantly influence the performance of the complete wind farm. Average power losses in large-scale wind farms are of the order of 10-20% [2]. A wake is characterized by a decreased wind speed and increased turbulence intensity. This results in complex inflow conditions for further turbines, which is an important field of study by itself, that is not yet fully understood. Therefore, an improved understanding of wake effects and their impact on individual turbines and wind farms is of great importance for the optimization of wind energy utilization.

Experimental investigations using model wind turbines are comparatively cost ef-

ficient, allow precise tuning of boundary conditions and enable the isolated study of certain effects. Further, an experimental approach is important for verification of and supplement to CFD simulations. Recently, several institutes used model wind turbines of different sizes and design to investigate numerous effects [3,4].

## Project Description

At ForWind Oldenburg, two identical model wind turbines were built in order to study wake effects and the impact of turbulent flow on the rotor experimentally in wind tunnel tests. Fig. 1 shows a photograph of the realized model wind turbine. The turbines have a rotor diameter of 0.58m and a hub height of 0.45m on an aluminum tower. The three rotor blades are based on the SD7003-airfoil and were produced by a vacuum casting method. The nacelle comprises a pitching mechanism that allows a collective change of the blade's pitch angle. A stepper motor equipped with an encoder is used for precise tuning and monitoring of pitch changes. Further, the generator connected to the main shaft features an encoder to measure the rotational speed of the rotor. The electric circuit comprises a field effect transistor (FET). By applying an external voltage to the FET, the electric current and thereby the electric load on the generator can be manipulated. This principle enables a control of the rotational speed and the torque of the turbine. Summarizing the setup, the measured variables of the model wind turbines are power, rotational speed, torque and the blades' pitch angle. Two NI-cRIO 9074 FPGA chassis with real-time controllers realize the data acquisition and control of the turbines. Therefore, appropriate LabVIEW-software was created.

First, the coherences of the different variables mentioned above and the wind speed were investigated in detail. Based on the data, an independent partial load control of

the model turbines was realized. Therewith, a stand-alone performance during varying inflow conditions is possible and the turbine automatically maximized its energy yield.

The partial load control was used to investigate the influence of the yaw angle and the pitch angle of one turbine on the performance of an array of both turbines. To do so, both turbines were set up in the wind tunnel in stream wise displacement. The downstream turbine (T2) utilized the partial load control in order to permanently maximize its energy yield, while the front turbine (T1) systematically varies its pitch and yaw angle respectively. Fig. 2 shows the wind tunnel setup schematically. To allow a change of the front turbine's yaw angle, it was placed on a turning table, which is controlled by a stepper motor. The procedures were fully automated and carried out for varying distances separating both turbines.



Figure 1: Photograph of the model wind turbine

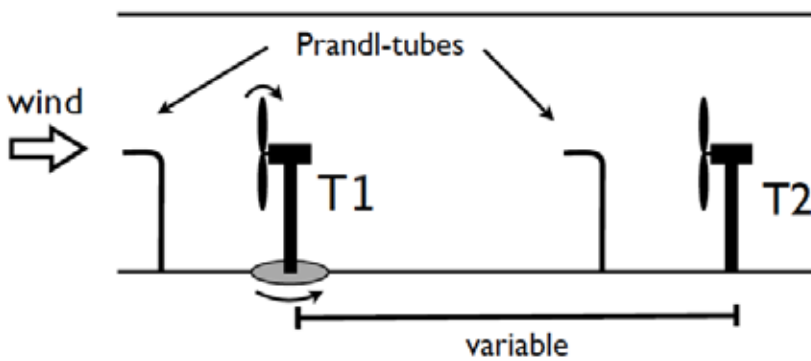

Figure 2: Schematic wind tunnel setup

The results show that both, a change of the pitch angle as well as a change of the yaw angle, have a measurable influence on the power output of the downstream turbine. Changing the pitch angle of T1 away from its aerodynamic optimum did not increase the overall power output of the turbine array. However, changing the yaw angle  $\gamma$  of T1 did increase the combined power  $P_1$  plus  $P_2$  for certain values, which can be seen in Fig. 3. More precisely, the power

could be increased by approximately 6% as compared to the case  $\gamma=0^\circ$  when setting the yaw angle of T1 to  $\gamma \approx 18^\circ$  [5]. This is in good agreement with simulation results of a similar case with two NREL-5MW turbines [6], although boundary conditions such as turbulence intensity and turbine spacing differed. Also, it was found that the total power strongly depends on the sign of the T1's yaw angle. This asymmetry is subject of further investigation in the future.

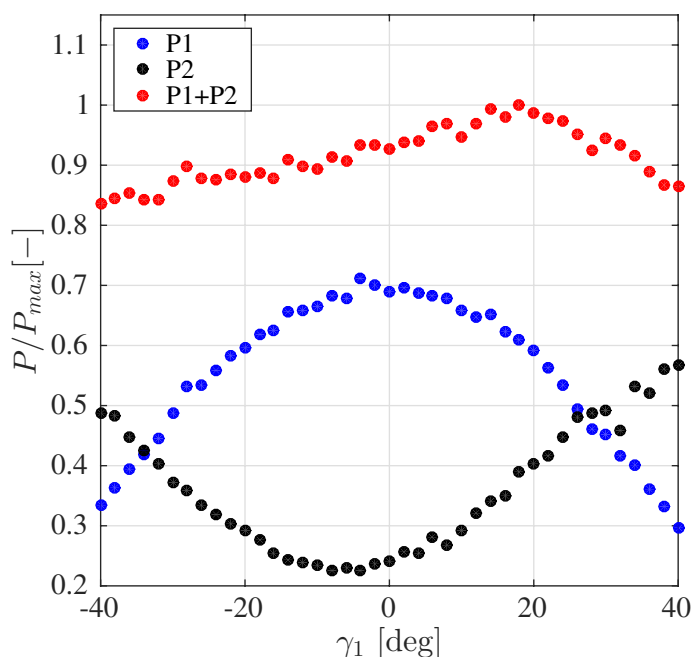

Figure 3: Normalized power output of the front turbine T1, the downstream turbine T2 and the combined power over the yaw angle of T1. Exemplary for three rotor diameters distance separating the turbines.

## Summary

At ForWind Oldenburg, two identical model wind turbines for wind tunnel experiments were designed, built and tested. The turbines feature a collective pitching mechanism as well as a torque control, which allows a stand-alone performance at varying inflow conditions. In first experiments, both model turbines were displaced in stream wise direction in the wind tunnel. The effect of a change of the yaw and pitch angle of the front turbine on the overall array's performance was investigated. The results show that a change in yaw and in pitch have a measurable influence on the downstream turbine, while only a change in yaw was able to increase the overall power output. This is in good agreement with simulations of a comparable scenario using two NREL-5MW turbines.

## References

- [1] Meyers, J.; Meneveau, C.: Optimal turbine spacing in fully developed wind farm boundary layers. *Wind Energy*, 15: pp. 305–317. doi: 10.1002/we.469 (2012)
- [2] Barthelmie, R. J.; et al.: Modelling and measuring flow and wind turbine wakes in large wind farms offshore. *Wind Energy*, 12(5), pp. 431-444 (2009)
- [3] Pierella, F.; Krogstad, P. Å.; Sætran, L.: Blind Test 2 calculations for two in-line model wind turbines where the downstream turbine operates at various rotational speeds. *Renewable Energy*, 70, pp. 62-77. (2014)
- [4] Bottasso, C. L.; Campagnolo, F.; Petrovič, V.: Wind tunnel testing of scaled wind turbine models: beyond aerodynamics. *Journal of Wind Engineering and Industrial Aerodynamics*, 127, pp. 11-28 (2014)
- [5] Schottler, J.; Herraes Hernandez, I.; Hölling, A.; Peinke, J.; Hölling, M.: Experimental investigation of controllable model wind turbines in different yaw conditions, Publication in progress
- [6] Churchfield, M.; Michalakes, J.; Spalart, P.; Moriarty, P.: High-fidelity simulation comparison of wake mitigation control strategies for a two-turbine case. ICOWES2013 Conference (2013)

# Smart Blades – Development and Design of Intelligent Rotor Blades

Carl von Ossietzky Universität Oldenburg  
Institute of Physics

Hauke Beck, Martin Bitter, Bastian Dose,  
Agnieszka Hölling, Michael Hölling,  
Tim Homeyer, Martin Kraft, Martin Kühn,  
Joachim Peinke, Francesco Perrone,  
Hamid Rahimi, Marijn van Dooren,  
Lena Vorspel

Partners: Leibniz Universität Hannover

Claudio Balzani, Moritz Bätge,  
Majeed Bishara, Carl Robert Brand,  
Johannes Ende, Benedikt Ernst,  
Seyedmehdi Garmabi,  
Jaione Ortega Gómez, Daria Horte,  
Eelco Jansen, Andreas Reuter,  
Raimund Rolfes, Jörg Seume,  
Alper Sevinc, Torben Wolff

Funding: Federal Ministry for Economic  
Affairs and Energy (BMWi)  
Ref.Nr. 0325601C (Hannover)  
0325601D (Oldenburg)

Duration: 12/2012 – 02/2016

## Introduction

Modern wind energy converters are increasing in size where at the same time acting and changing loads on the rotor blades become more and more an issue not only for the blade design but also for the operation of these turbines. Within the smart blades project different components will be developed and tested that should decrease the aerodynamic loads and their fluctuations, respectively. In close cooperation with the German Aerospace Center (DLR) and the Fraunhofer Institute for Wind Energy and Energy System Technology (IWES), ForWind Hannover and Oldenburg are participating with their wide variety of expertise in each part of the project, which is organized in four technologies. Table 1 provides an overview of the covered topics at the different institutes and research groups.

## Project Description

### Technology 1 – Passive Smart Blades with bend-twist coupling

The focus of Technology 1 is the investigation and design of wind turbine blades which feature bend-twist coupling as a passive load control mechanism to reduce the aerodynamic loads. ForWind is in charge of tasks that deal with the development of new numerical simulation tools and controller concepts. The new tools are based on Computational Fluid Dynamics (CFD) which delivers high resolution flow fields. As normal CFD simulations cannot capture the effect of bend-twist coupling due to the assumption of stiff geometries, a structural model for wind turbine blades was implemented into the open source CFD toolbox OpenFOAM [1].

A finite element solver using beam elements was developed and coupled to OpenFOAM flow solvers. In the next step, the code will be used for the aerodynamic analysis of flexible blades. Figure 1 shows a deformed beam structure simulated with the coupled solver. In addition, an optimization tool for complete wind turbine blades is currently being developed. Using this tool, the optimal aerodynamic shape of deformed blades under various load conditions shall be determined. The optimization will be performed using the adjoint method, which was implemented into the open source CFD tool OpenFOAM [2]. Recently, a test case for blade airfoils was set up for a comparison with other optimizers regarding speed, stability and the optimal solution.

ForWind is also involved in the development of new controller concepts that include the bend-twist deformation or advanced pitch and torque strategies, respectively. Therefore, the usage of supplementary sensors for online-detection and control of the deflection should be investigated. A first

baseline controller for the reference wind turbine has already been designed and is used to identify further improvements.

For the detailed investigation of the geometrical bend-twist-coupling, swept blades have been implemented successfully into a full aeroelastic simulation environment. A modification of the reference turbine was coupled with the swept blade configuration (see Fig. 2) to simulate the system behavior in full turbulent inflow conditions. Additionally, unsteady effects (e.g. dynamic stall, dynamic wake, tower shadow, etc.) can be considered for the further development of the geometrical bend-twist coupling. This new turbine model is the baseline for further investigations for the parametric studies of the swept blade. Loads on the whole turbine structure and performance calculations can be compared directly with the reference turbine to determine the advantages and disadvantages of the geometrical bend-twist-coupling. Furthermore parametric studies to determine the characteristics of the swept blade are performed within the aeroelastic environment.

By increasing the blade's length and using slender blade designs aeroelastic stability must be investigated in detail to determine safe operation of the turbine without fluttering. Therefore, a task was shifted from Technology 4 to Technology 1 to create a method for the flutter analysis of rotor blades.

### Technology 2 – Smart Blades with active trailing edge

Technology 2 deals with the development of smart rotor blades with trailing edge flaps and actively deformable trailing edges. These concepts are typically applied in the outer part of the rotor blade to reduce the loads acting on the wind turbine. ForWind is investigating structural, aerodynamic as well as aeroacoustic problems of smart blades with active trailing edges.

<b>Technology 1 – Passive Smart Blades with bend-twist coupling</b>	
Automated aerodynamic optimization of blades	TWiSt
Integration in Pitch and Torque control	WESys
Coupling of different aerodynamic levels	TWiSt
Bend-twist coupling with swept curvature	IWES
Aerodynamic of fluid-structure coupling	TWiSt
Design of a small blade with structural bend-twist coupling	IWES
Aeroelastic stability of passive Smart Blades	IWES
Material and component tests	IWES
<b>Technology 2 – Smart Blades with active trailing edge</b>	
Tools for structure and fatigue analysis	ISD
Aerodynamic model for blades with trailing edge flap	IWES
Sensors for trailing edge flap and turbulent inflow in rotor plane	WESys
Integration in Pitch and Torque control	WESys
Coupling of different aerodynamic levels	TWiSt
Strength and dynamic analysis of blades with moveables	ISD
Flow simulation and acoustic emission estimation of blades with flaps	TFD
Flow calculation with flexible trailing edge	TFD
Aeroelastic stability of active Smart Blades	IWES
<b>Technology 3 – Active slat</b>	
Wind tunnel test with slats	TWiSt
<b>Technology 4 – Cross-Technology Topics</b>	
Anisotropic bionic structural optimization	IWES
Aerodynamic and structural design of reference turbine	IWES
Technical and economical evaluation	IWES
Systems Design Engineering - Reliability	WESys

Table 1: Research topics of institutes and work groups

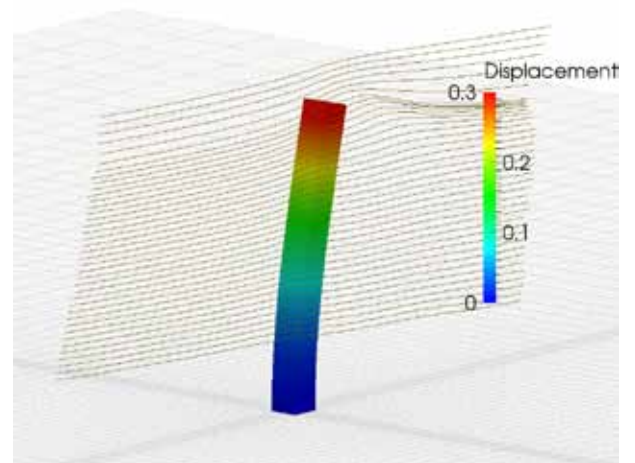

Figure 1: Stream lines around a deformed beam



Figure 2: Swept blade turbine configuration

Determining the structural characteristics of the long and slender blades with active trailing edges, applied within this context, is a key issue. An appropriate modeling capability for structural analysis is required when exploiting the possibilities of smart rotor blades. Therefore, a typical Finite Element (FE) discretization using shell elements was chosen as a basis for fatigue, strength and vibration analysis. To facilitate the structural modeling and analysis activities an input generator for the FE program ABAQUS has been developed. The FE input generator is based on Matlab and considers the blade geometry, the blade and spars stiffness properties, and the laminate lay-up of the blade skin as input parameters (Fig. 3).

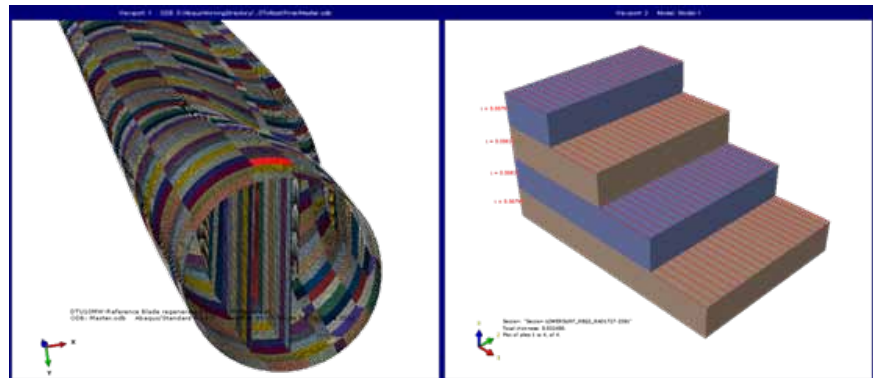

Figure 3: Internal geometry and laminate lay-up of rotor blade Finite Element model, generated with FE input generator tool.

The capability of the FE input generator tool includes incorporation of a morphing trailing edge mechanism. Its position, size and internal geometry are parameterized input data for the FE input generator. The FE input generator has been verified by applying the tool to regenerate an existing 36.5 m rotor blade model available at For-Wind. Preliminary strength and vibration analyses have been carried out with several Finite Element models produced with the tool. To demonstrate the capability of the tool to generate models for parameter studies, a variation of the position of the shear webs has been carried out in a series of blade vibration analyses of the 36.5 m blade model [3]. In future work the FE input generator tool will be used to generate FE models for the investigation of specific configurations relevant for the Smart Blades project, and can in particular also be employed to carry out sensitivity studies and optimization studies for important structural parameters. Vibration and stress analyses have been performed for the 80 m reference blade available within the Smart Blades project. In the context of strength analysis, a new hybrid micro-meso modeling approach has been developed at ISD to simulate the progressive failure of multi-directional laminates considering the interaction between four failure mechanisms, namely fiber kinking, splitting, matrix cracking and delamination. The integration of such local strength analysis approaches

in the global stress analysis of large rotor blades will be subject of further studies.

To quantify the aerodynamic influence of a deformable trailing edge and a flap on lift coefficient and stall behaviour, a parametric study of a flap has been performed using XFOIL (see an example in Figure 4). Therein, the impact of the chord-wise flap size and the flap deflection angle on the lift and drag coefficients of a NREL 5MW reference turbine airfoil as well as a profile of the Smart Blades reference blade has been analyzed. Special attention was turned to the change of lift-to-drag ratio and the load reduction potential of trailing edge flaps [4]. In order to study the influence of the non-stationary effects on the aerodynamic coefficients during pitch motion or flap motion, an engineering model for unsteady

aerodynamics has been implemented in Matlab. Validation with CFD results will be performed in near future.

In addition, two-dimensional flow simulations with an actively deformable trailing edge have been performed, i.e. to point out potentially critical control sequences. A time lag between trailing edge deflection and the resulting load change can cause unfavorable aerodynamic conditions, in the worst case even increasing loads and aeroelastic instabilities. Thus, this time lag is analyzed in detail to hand out recommendations for the controller design. It was found out that the time lag depends on the angle of attack and the velocity of the deflected trailing edge [5]. Unsteady simulations with angle of attack and trailing edge deflection oscillating in a predefined way

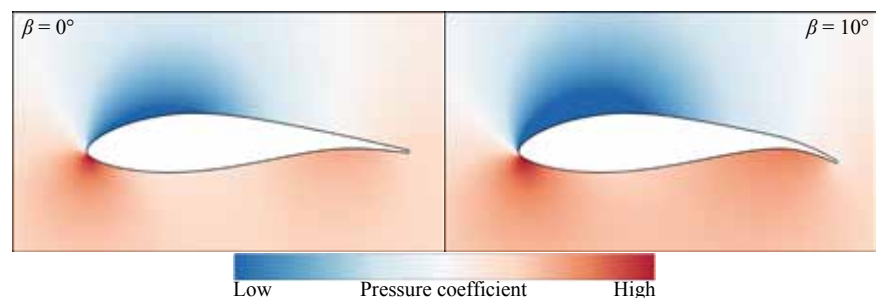

Figure 4: Distribution of the pressure coefficient for the reference airfoil (left) and a  $\beta=10^\circ$  deflected trailing edge (right).



have been carried out to investigate the load reduction potential of a deformable trailing edge. The results show a reduction of the lift amplitude to as little as 6% of the lift amplitude resulting from the angle of attack oscillations if the trailing edge oscillates in counter-phase to the angle of attack oscillations. In 2015, a simplified model, which considers the influences of a flexible trailing edge for the simulation of the whole wind turbine will be developed.

ForWind is also involved in the development of new controller concepts including trailing edge flaps and their capability of load reduction. Therefore, the 7.5 MW reference turbine with flaps was implemented into an aeroelastic simulation tool, where an additional control loop was added to alleviate the 1P cyclic flap-wise loading of the blade root. Simulations were carried out according to the IEC 61400-1 standard, and preliminary damage equivalent loads (DEL) analysis was performed. This prior investigation clearly points out the positive effect introduced by the control of the trailing edge flaps. In line with this de-

velopment the incoming wind field has to be defined accurately to gain realistic input parameters for controlling the trailing edge flaps. To be able to measure data of the incoming wind field across the whole rotor area, ForWind acquired a high speed short-range ZephIR 300 LiDAR within the Smart Blades project, which is currently being upgraded to a spinner-mountable LiDAR. This LiDAR will be used to scan the incoming wind speed component on a spherical cap with the typical ‘rosette’ scanning pattern (Figure 5). At end of 2015 the spinner LiDAR will be mounted on a wind turbine to measure inflow wind fields at close upstream distances with a data rate of 400 Hz. This data will also be help to specify boundary conditions for wind tunnel measurements and numerical simulations of a full wind turbine with smart blades.

### Technology 3 – Active slat

In Technology 3 a deformable adaptive slat was developed in cooperation with the DLR. ForWind is mainly involved in wind tunnel tests to investigate the potential to

affect aerodynamic forces particularly under turbulent inflow conditions. Therefore, the DU 91-W2-250 profile was chosen for the baseline shape. During the project experiments with the basic profile (clean shape) as well as with a superimposed and integrated slat are planned. For the measurements a new closed test section of 2.6 m length with optical access from all sides was built and mounted to the 1 x 0.8 m<sup>2</sup> nozzle of the Göttingen type wind tunnel in Oldenburg. Here, the profiles are placed vertically in their quarter-chord point on an axis, which is connected to a torque sensor and force balances that measure at high sampling frequencies the acting aerodynamic forces. The whole mounting is decoupled from the rest of the section to enhance the quality of these measurements. Additionally, the pressure distribution on the profiles surfaces is measured with up to 45 pressure taps that are connected to pressure scanners through tubes. Mean pressure distributions at different angle of attacks are gained that allow the identification of separation bubbles and the calculation of polar lines. In the wind tunnel walls 80 pressure sensors are positioned, that measure the pressure distribution on the suction and the pressure side in the tunnel. With this the lift coefficient can also be calculated. These three redundant techniques have been tested under laminar inflow conditions with consistent results. The superimposed slat is designed for a delayed stall and higher maximum lift. First measurements in laminar conditions confirm this. Figure 6 compares the lift, drag and moment coefficients of the clean shape model with the coefficients of the superimposed slat model for a Reynolds number of 1 million.

The turbulent inflow conditions for the experiments are generated by means of an active grid that can be mounted on the nozzle of the wind tunnel. This grid allows generating turbulent inflow conditions based on predefined control protocols that result in realistic fluctuations in wind velocities as well as in angles of attack at the position of the profile. One focus of this project is to analyze local unsteady flow phenomena like separation effects at high temporal resolution in such turbulent flows. Therefore, a High Speed Stereo PIV System is used. The laser light

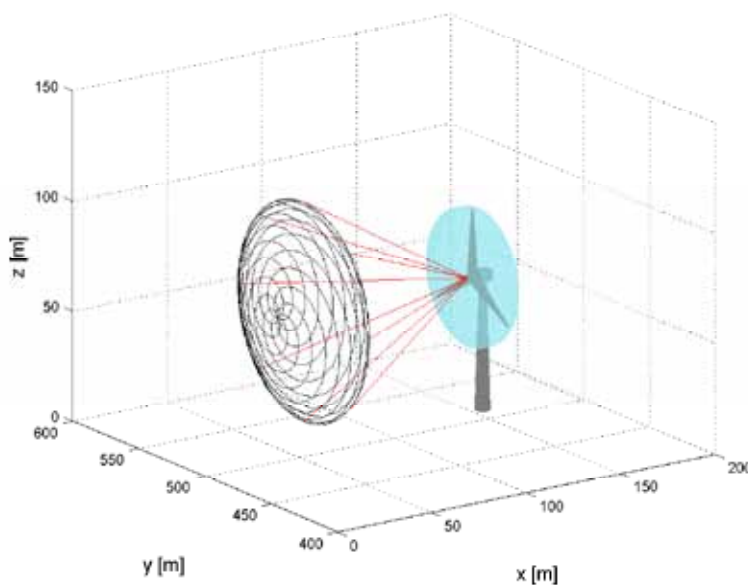

Figure 5: Exemplary simulated rosette scan pattern of a spinner LiDAR.

sheet is coupled into the wind tunnel and is adjusted perpendicular to the surface of the airfoil. Two cameras above and under the test section are focused through the Perspex in mainly front scattering mode. In Figure 7 a PIV snapshot of a measurement at 700Hz is shown for the clean profile at 18° angle of attack and a Reynolds number of approximately 200,000. An excitation protocol that produces turbulent angle of attack fluctuations of  $\pm 6^\circ$  with a periodicity of 5Hz at the leading edge of the profile was used for the active grid.

With optical measurements at such high temporal resolution it is possible to track the movement of the separation point and resolve the local dynamics. In contrast to laminar inflow conditions where the separation is relatively fixed at one position, the separation point is moving over a wide range of the chord for the turbulent case. The separated shear layer is clearly visible and it's flapping and mixing with the outer flow is synchronous with the fluctuations of the angle of attack.

The turbulence and the unsteady separation result in aerodynamic forces whose extreme dynamics have to be attenuated. For this purpose the potential and the limits of the profile with an active slat will be investigated in further experiments.

#### Technology 4 – Cross-Technology Topics

Activities that cannot be linked directly to a single investigated technology are integrated in the cross-technology topics and comprise the development and detailed specification of a state-of-the-art and load-optimized reference turbine for loads simulation purposes, and the development of reference blades on a level of detail that has never been reached in past research projects. Finally, a multi-criteria analysis with focus on technological and economical aspects is in development, which is supported by systems design engineering focusing on reliability analyses, and load simulations performed by Fraunhofer IWES in order to study the impact of load reduction at the blades on subsequent turbine components.

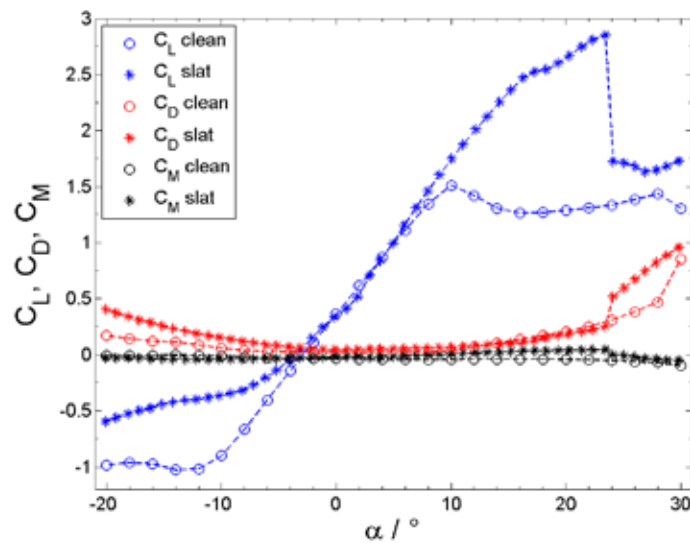

Figure 6: Lift, drag and moment coefficients ( $C_L$ ,  $C_D$  and  $C_M$ ) measured in laminar conditions ( $Re \approx 1$  million.) with the force and torque sensors for several angles of attack  $\alpha$  of the clean shape model and of the model with superimposed slat.

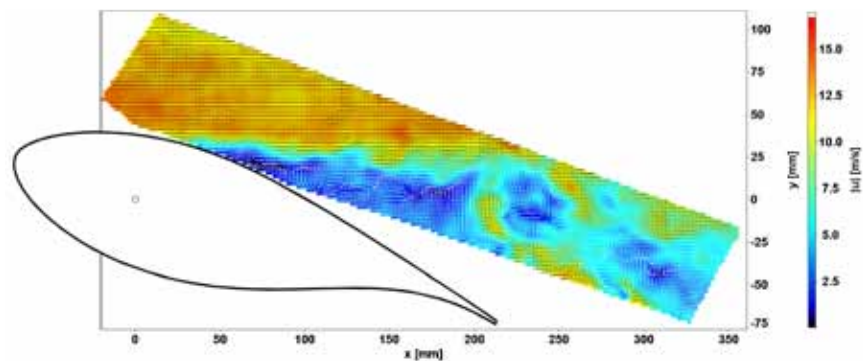

Figure 7: Snapshot of the High Speed Stereo PIV measurement at 700Hz of the clean profile at 18° angle of attack and a Reynolds number of approximately 200,000 for turbulent angle of attack fluctuations of  $\pm 6^\circ$ . The absolute value of the three dimensional velocity field is color-coded.

As a basis for the comparative evaluation of the smart blade technologies, a reference turbine, a model of a 7.5MW direct drive near shore turbine with a rotor diameter of 164m and advanced load-reduction features such as individual pitch control, has been specified by Fraunhofer IWES, together with ForWind. Further, the design of a flexible state-of-the-art reference blade with a total length of 80m has been

completed in strong cooperation between these two partners. The topology of the reference blade consists of a main spar with UD carbon/epoxy spar caps and two shear webs, one additional shear web in the trailing edge region with maximum chord, and UD glass/epoxy leading and trailing edge spar caps, (see Fig. 8). Buckling problems occurred in the spar caps for the initial configuration. An elaborate study

has been performed where three alternative concepts have been investigated [6]: Two split spar cap designs with a width of 200mm and 300mm each, respectively, and a continuous spar cap design stiffened by sandwich core material. High-fidelity finite element analyses showed that the 200mm split spar cap design resulted in a minimum required additional mass to solve the buckling problems.

Another modeling activity was the development of a bionic optimization tool for the structural design of smart rotor blades. The functionality of ANSYS has been tested in the bionic optimization of the blade topology. Therein, material is built in where it is necessary, and is removed in other positions, which is represented by an increase or a decrease of mass density, respectively (see Fig. 9).

Smart Blade technologies add extra behaviour and/or supplement structures and systems to the wind energy converter. This can yield additional risks in reliability or availability of the system. For comparison of the new design concepts the baseline reference turbine design has been evaluated in the context of reliability. The model has been built up and analysed with respect to functions and faults of the system. Relevant design drivers for reliability have been identified in the blade structure itself, the lightning protection, and especially the pitch system. The reliability analysis procedure includes methods such as failure databases, fault trees and expert interviews, leading to qualitative levels of reliability and availability for the active and passive Smart Blade with respect to the reference model and indicators for optimization potentials.

Further, the framework of the evaluation model has been set up. This model is a combination of VDI 2225 [7] and weighted value benefit analyses. An elaborate technological evaluation catalogue comprising minimum requirements, main criteria, sub-criteria, and performance indicators has been created. In order to quantify the weighting factors large bandwidth of weighting methods have been considered.

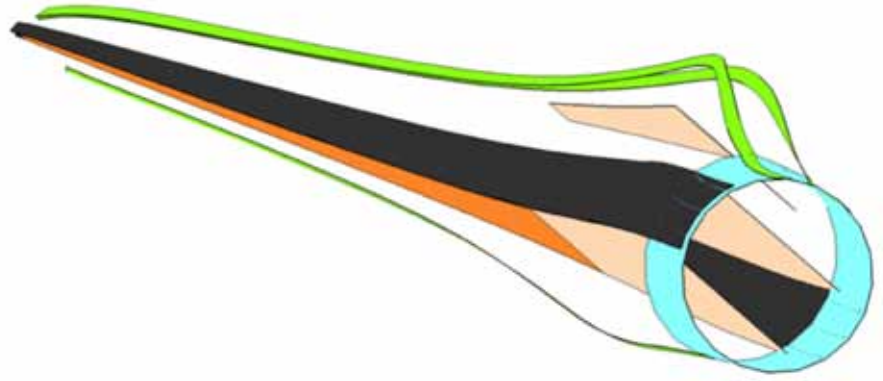

Figure 8: Topology of the reference blade, developed by Fraunhofer IWES in cooperation with ForWind.

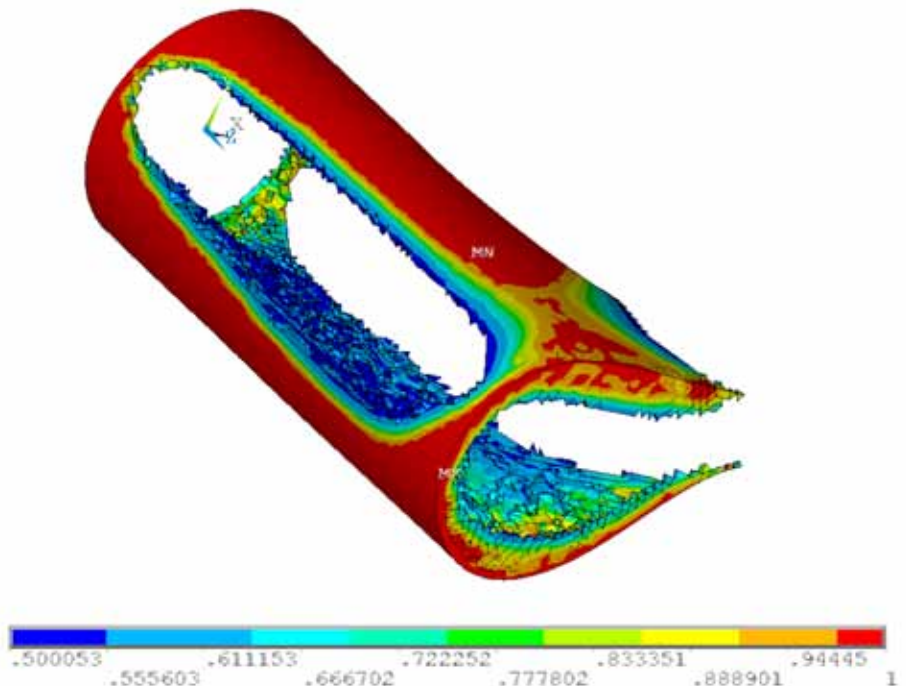

Figure 9: Optimized topology of a blade root section (red: reference mass density, blue: 50% reduced mass density).

The SMART method [8] seems most appropriate for follow-up expert interviews in which, besides the evaluation itself, the weighting factors are to be determined. For the economical evaluation a mass-related life cycle cost model has been developed which links the component masses to the component costs. The levelized cost of energy (LCoE) is calculated via a static cost analysis. The extraction of power curves from the loads simulations in the different technologies, as well as the determination of the corresponding annual energy yield needed for the calculation of the LCoE for the different technologies is work in progress.

## Summary

Within the Smart Blades project five institutes and research groups of ForWind Hannover and Oldenburg are involved in the development of new numerical simulation tools, controller and blade design concepts for Technology 1 (passive Smart Blades). Amongst others, fluid structure interaction was added to the tool chain that allows aerodynamic analysis for flexible blades. In Technology 2 ForWind is part of structural, aerodynamic and aeroacoustic investigations regarding the concept of an active trailing edge. On the structural side a finite element model has been used to optimize the internal geometry as well as the laminate lay-up of a rotor blade with active trailing edge flaps. Wind tunnel experiments including High-Speed PIV under turbulent inflow conditions are the basis for a better understanding of the effectiveness of slats in Technology 3. In the cross-technology topics ForWind helped to develop a 7.5 MW reference wind turbine model for loads simulation purposes and corresponding reference rotor blades including detailed lay-up specifications. Furthermore, ForWind develops a holistic evaluation model including technological and economical aspects as well as reliability analyses for the turbine concepts under investigation.

Supported by:



Federal Ministry  
for Economic Affairs  
and Energy

on the basis of a decision  
by the German Bundestag

## References

- [1] Dose, B; Stoevesandt, B.; Peinke, J.: FSI on wind turbine blades using OpenFOAM, 9th PhD Seminar on Wind Energy in Europe, Sweden (2013)
- [2] Vorspel, L.; Stoevesandt, B.; Peinke, J.: Optimization of rotor blades using adjoint methods in OpenFOAM, 9th PhD Seminar on Wind Energy in Europe, Sweden (2013)
- [3] Garmabi, S.M.; Jansen, E.L.; Rolfes, R.: Towards vibration analysis tools for smart rotor blades, 10th PhD Seminar on Wind Energy in Europe, Orleans, France (2014)
- [4] Ortega Gómez, J.; Balzani, C.: Load reduction potential on large wind turbines using active trailing edge flaps, Conference of the Wind Power Engineering Community (CO-WEC), VDI Wissensforum, June 18th-19th, Berlin, Germany (2013)
- [5] Wolff, T.; Ernst, B.; Seume, J.R. : Aerodynamic Behavior of an Airfoil with Morphing Trailing Edge for Wind Turbine Applications, The Science of Making Torque from Wind 2014, June 18th-20th, 2014, Copenhagen, Denmark (2014)
- [6] Rosemeier, M.; Bätge, M.: A concept study of a carbon spar cap design for a 80m wind turbine blade, The Science of Making Torque from Wind 2014 (TORQUE 2014), Journal of Physics: Conference Series 524 (2014) 012039, doi:10.1088/1742-6596/524/1/012039
- [7] VDI Richtlinie 2225 Blatt 3: Technisch-wirtschaftliches Konstruieren, Technisch-wirtschaftliche Bewertung, VDI-Verlag, Düsseldorf, 1997
- [8] Wang, J.-J.; Jing, Y.-Y.; Zhang, C.-F.; Zhao, J.-H.: Review on multi-criteria decision analysis aid in sustainable energy decision-making, Renewable and Sustainable Energy Reviews 13, pp. 2263-2278 (2009)



# A Risk Analysis and Management Tool for Offshore Wind Energy Projects and Operation

Leibniz Universität Hannover  
School of Economics and Management  
Information Systems Institute

Michael H. Breitner, Jan-Hendrik Piel,  
André Koukal

Project partner: Hannover Center of  
Finance e.V. and NORD/LB, Hannover

Duration: Since 2012

## Introduction

The current German government strives for a great expansion of offshore wind energy in the German parts of North and Baltic Seas. According to expansion targets specified in the Renewable Energy Sources Act, a total of 15 GW of offshore wind energy capacity is to be installed until 2030. But, at the end of 2014 total capacity of only 0.6 GW was actually installed [1]. Reaching the ambitious expansion targets thus requires a large number of investors willing to make cumulative investments of between 38 billion to 52 billion Euro. However, many potential investors are currently facing budgetary constraints due to consequences of financial crises in recent years. Although the average return on investment (RoI) of offshore wind energy projects is quite attractive, these investors avoid investments due to difficult, inaccurate Value-at-Risk (VaR) analyses. Today, the impacts of the 10 to 15 main risks and their correlations are not well understood. Consequently, investors demand high equity and loan capital risk premiums, which unacceptably increase total system costs of offshore compared to onshore wind energy projects.

## Project Description

In order to be able to stimulate the investors' future willingness to invest, comprehensive methodological support is needed enabling investors to make investment decisions based on a combination of cost-benefit and total risk analyses. This methodological support needs to account for both technical and financial risks. As a first step we developed a financial decision support system (FDSS) assessing offshore wind energy projects and their general financial conditions. A discounted cash flow (DCF) model in combination with a business risk model (BRM) was implemented and a Monte Carlo simulation (MCS) was applied. The resulting tool enables investors to analyze and evaluate the probabilistic project value (Fig. 1) of an offshore wind energy project within a project finance framework and allows to

analyze and manage project risks. To consider requirements of typical investors, key figures as for example the average return on investment and different debt coverage ratios (Fig. 2) can be calculated. Development of the first FDSS was performed within an Excel/VBA programming environment extended by the Excel-add-in Oracle Crystal Ball. At first, an offshore wind farm example in the German North Sea was investigated to validate the underlying risk model and the FDSS [2]. Results were analyzed, limitations were identified and further improvements were derived. After implementation of advancements, as for example the Weibull wind speed distribution, the FDSS was again applied to the same case study, but also to several further case studies, including offshore wind energy projects in emerging countries (Brazil and Mexico) [3].

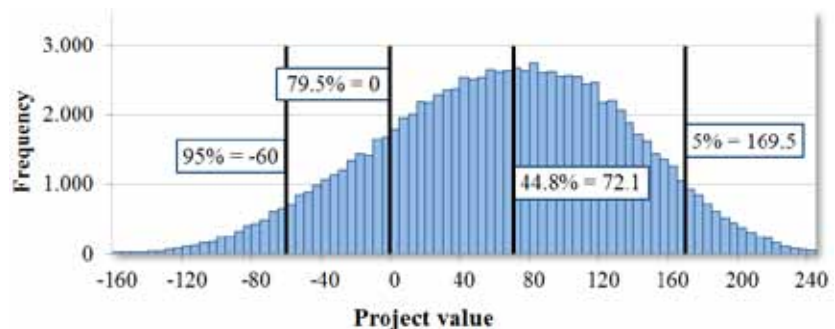

Figure 1: Distribution of the Project Value (Adjusted Present Value in Million €) of a German Offshore Wind Energy Project [2]

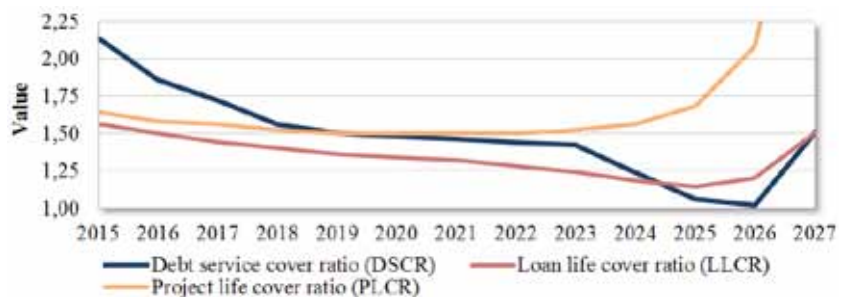

Figure 2: Debt Coverage Ratios of a German Offshore Wind Energy Project at a specified Confidence Level of 95% [2]

## Summary and Outlook

As the offshore wind energy and renewable energies in general as well as our system aim at technical, ecological, and economic sustainability, the application can be classified as green by information systems. The FDSS is able to support investors with the complex tasks of assessing possible project returns and the project's ability to cover debt service. Moreover, governments can

check whether the respective general financial conditions are sufficient to support the expansion of the offshore wind energy. Nevertheless, we also identified certain limitations with regard to our research project. Especially the fact that the FDSS does not account for risk correlations has made evident the need for the development of a more powerful FDSS. When simulating risk correlations in Monte Carlo simulations via Iman-Conover method, a larger amount of

random numbers must be generated. As this would lead to unacceptable computing time when using the less performant Excel/VBA FDSS, we started to develop a second, MATLAB-based, multi-step, probabilistic scenario analyses FDSS in 2015 (Fig. 3). This second FDSS optionally can use coarse- and fine-grained parallelization on up-to-date processors and multi-processor computers.

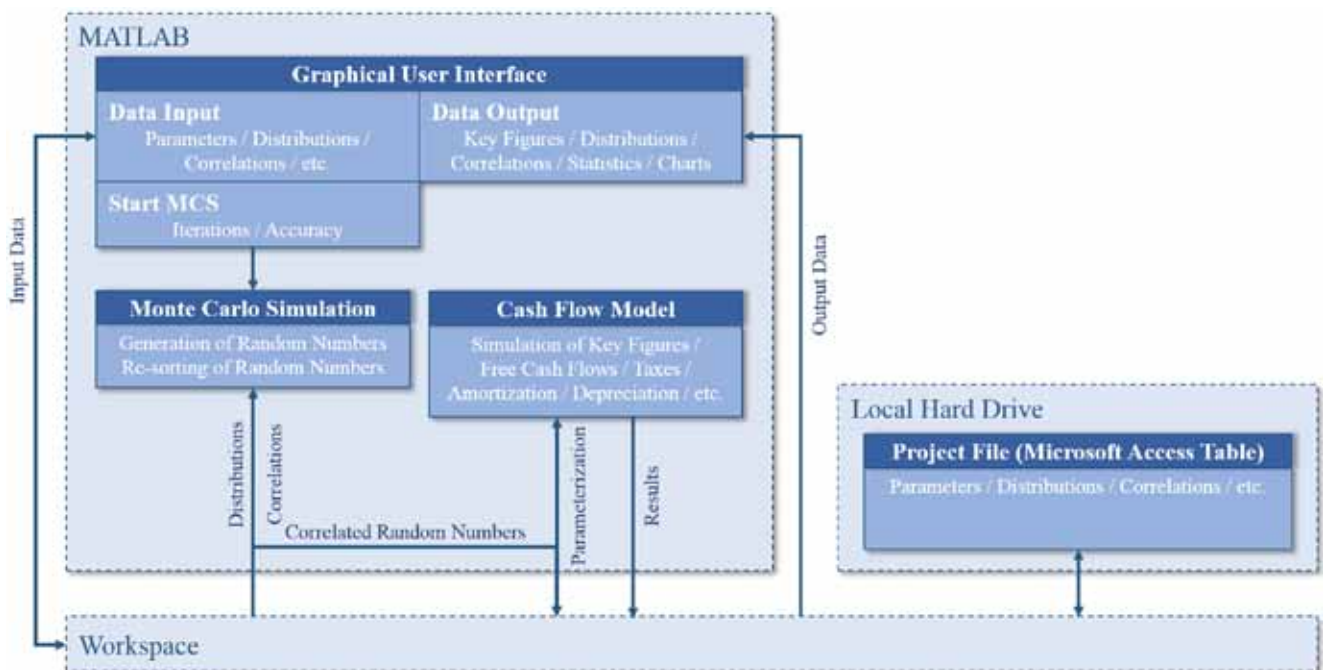

Figure 3: System Architecture of the MATLAB-based, multi-step, probabilistic scenario analyses FDSS

## References

- [1] EWEA (2015). The European offshore wind industry - key trends and statistics 2014. <http://www.ewea.org/fileadmin/files/library/publications/statistics/EWEA-European-Offshore-Statistics-2014.pdf> [Retrieved September 24th 2015].
- [2] Koukal, A., Breitner, M. H. (2013). A Decision Support Tool for the Risk Management of Offshore Wind Energy Projects. 11th International Conference on Wirtschaftsinformatik Proceedings 2013, 14 p.
- [3] Koukal, A., Breitner, M. H. (2014): Offshore Wind Energy in Emerging Countries: A Decision Support System for the Assessment of Projects. Hawaii International Conference on System Sciences Proceedings 2014, pp. 865-874.

# mapretec

Universität Bremen  
 Institute for Integrated Product  
 Development (BIK)

Jan-Hendrik Ohlendorf, Martin Rolbieceki,  
 Tim Schmohl, Jan Franke

Funding: Federal Ministry for Economic  
 Affairs and Energy

Ref.Nr. 329926C

Duration: 12/2010 – 05/2014

## Introduction

Increase the percentage of automation in the rotor blade manufacturing process is the topic of the research project mapretec [1]. Rotor blades for wind turbines are normally made of long-fibre reinforced polymer composites due to their beneficial strength-to-mass relationship und extraordinary stiffness. Because of the high number of technical textiles plies, the employment time of the manual process and the pro-

duction quality is highly influenced by the experience, knowledge and intuition of the engaged employees.

With regard to the background of employment at sea, an increase of quality requirements of the manufacturing in combination with the increasing blade length, the manual production process is less effective. Faults in quality may lead to failure, repair or even replacement meaning great expenses. With textile draping different effects can occur such as incorrect positions of rovings or the entire layer. This may cause negative effects on the strength or mechanical characteristics of the construction unit. In order to keep these effects as small as possible, the automation of draping and cutting processes is a solution.

## Project Description

In the mapretec project, the technical textiles are laid automatically on special carriers by building a flat preform and then finalised in contour mould of the rotor blade by

using the Compact Moulding Technology (CMT). Special fixing technologies are used to avoid the uncontrolled moving effects of each layer.

Additionally innovative sensor technology is used to identify the parameter to control the automation process.

The combination of the automation, the preform technology and the liquid composite moulding (LCM) is used for a new process chain with advantages of accuracy in positioning and repeatability as well as an increasing production speed.

## Summary

This process chain for the automated manufacturing of rotor blades is realized by a production cell concept with an innovative control and quality system. This project is funded by the German Federal Environment Ministry (BMU) and is realized in cooperation with the SAERTEX GmbH & Co. KG and support of the rotor blade manufacturer AREVA Blades GmbH.

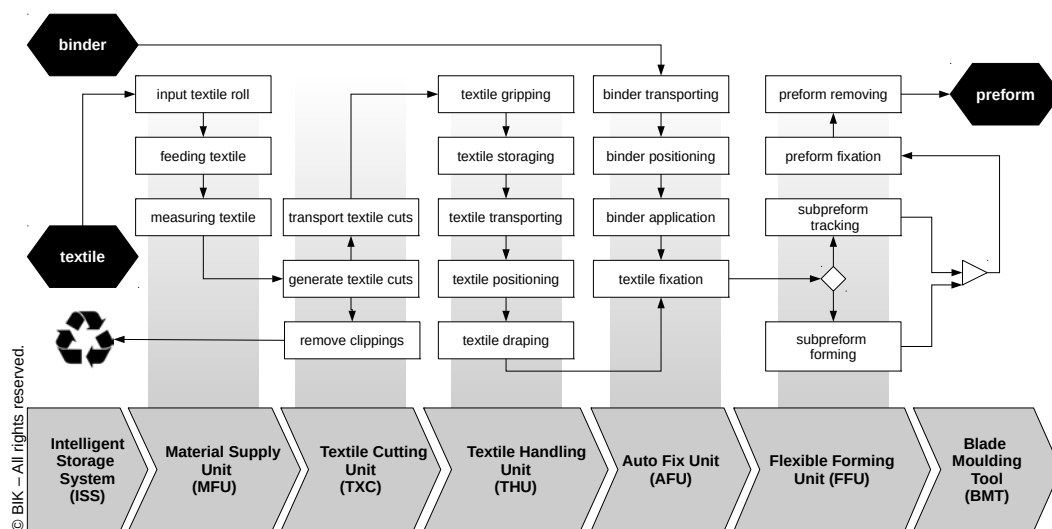

Figure 1: New preforming process





Figure 2: Material supply unit with ultrasonic cutter system and adaptive handling unit



Figure 3: Auto Fix Unit mounted to the articulated arm

#### References

- [1] Ohlendorf, J.-H. ; Rolbiecki, M. ; Schmohl, T. ; Franke, J. ; Ischtschuk, L.: mapretec – ein Verfahren zur preform-Herstellung durch ebene Ablage für ein räumliches Bauteil als Basis einer automatisierten Prozesskette zur Rotorblattfertigung: Universität Bremen, Institut für integrierte Produktentwicklung (BIK); SAERTEX GmbH & Co. KG., 2015, <https://doi.org/10.2314/BV:849726018>

# BladeMaker – University of Bremen

Universität Bremen  
Institute for Integrated Product  
Development (BIK)

Martin Rolbiecki, Jan Franke,  
Marvin Richrath

Funding: Federal Ministry for Economic  
Affairs and Energy  
Ref.Nr. 0325435E

Duration: 10/2012 - 09/2017

## Introduction

The main focus of the project "BladeMaker" is the manufacturing chain for rotor blade production with the target on reducing production cost by more than 10 percent. For this reason 17 industrial and research partners will consider on rotor blade design, materials and manufacturing processes. The main objective of this project is the set up of the "BladeMaker Demo-Centre".

## Project Description

The manufacturing costs of rotor blades account for one quarter of the total cost of a wind energy turbine, a fact which results from the high proportion of manual labour involved. Rotor blades for wind turbines are made of composites and were designed to bear considerable loads. These large scaled lightweight-components (up to 90 meters length) are predominantly manufactured in manual processes. Consequences are variations in the quality of the product depending on the chosen method of production and the individual state of knowledge of the involved employees.

The University of Bremen is involved in two thematic areas: "Direct Textile Placement" and "Tooling Design". The main focus of "Direct Textile Placement" is the development of a device for automated handling of textiles to produce large scaled preforms for rotorblades. One of the most significant challenges is the precise lay-up of the textiles into the multi-curved forming tool. Beside resin infusion, the preforming-process decides about the quality of the finished product. Especially the handling of dimensionally instable non crimp fabrics is one of the critical process steps in this chain. Although this field is a long-standing object of research and development in industry and research institutions, there is still room for improvement in terms of process stability and costs. The objective of "tooling design" is to obtain qualitative statements to the formation of micro-and macro-pores in the polymer matrix of the composite followed by analytical and numerical description.

## Summary

The project BladeMaker will run until the end of September 2017 and is funded with 8 million Euro by the German Federal Ministry for Economic Affairs and Energy (BMWi). The University of Bremen is one of 17 partners and is focused on the development of forming-tools and the automated preforming process. The developed systems will be integrated in the "BladeMaker Demo-Centre" and will be tested under industrial conditions.



# Enhancing the Availability and Quality Optimization of Drive Train Components and Gears in Wind Energy Systems

Universität Bremen  
Bremen Institute for Metrology,  
Automation and Quality Science (BIMAQ)

Jan F. Westerkamp, Dirk Stöbener

Funding:  
Federal Ministry for the Environment,  
Nature Conservation, Building and  
Nuclear Safety (BMUB)  
Ref.Nr. 0325490A

Duration: 09/2012 – 08/2015

## Introduction

Wind turbines are plants with high dynamic loads which most of the time are operated at partial load. This untypical load profile and lack of knowledge in the consideration of this mode of operation in the design of gearboxes has led to increasing numbers of bearing and gear failures in many different wind turbine types.

Even though the failure rates of wind turbine drive train components are low compared to other components, they result in long downtimes. A targeted approach for advances in design, production and material selection requires significant measurement data [1].

This project aims at the sustained long term provisioning of reliable measurement data of large gears for wind turbines. This enables the wind energy industry to increase the operational availability of wind turbines and decreases the identifiable costs.

## Project Description

The capability of the measurement techniques in the automotive industry led to highly developed gear manufacturing processes which cannot easily be scaled up to

large gears for wind energy systems. Therefore, a reliable, near-process measurement of large gears is an essential requirement for the future development of the manufacturing techniques for wind energy systems. Advances in the measurement processes will create technical and economic innovation potential for wind energy systems, especially regarding longer lifetime, increased efficiency of the power transmission, reduced noise emissions and smaller overall size. The expected economic advantages include optimized production processes and an increased yield of the wind turbine.

The project is carried out by three partners:

- Bremen Institute for Metrology, Automation and Quality Science (BIMAQ) at the University of Bremen;
- German National Metrology Institute (Physikalisch-Technische Bundesanstalt – PTB);
- Hexagon Metrology GmbH.

The basis for the intended reliable measurements is the implementation of a fully traceable chain of procedures beginning at the PTB via accredited laboratories under the supervision of the national accreditation body, Deutsche Akkreditierungsstelle (DAkKS), down into the industry. The connection to the SI unit of the PTB is established by substitution measurements on high-precision, calibrated standards [2]. These standards can be gears with a diameter of up to 3 m or qualified gear segments. During the project a large gear standard which regards industrial requirements is developed. This is the basis for the traceability chain and the calibration of large gears as subsequent standards for the use in the industry. The objective for the development of the large gear standard is a calibration chain as short as possible, which enhances the achievable measurement uncertainty at the end of the calibration chain (in the industrial application).

In order to ensure that the newly developed standard itself can be calibrated, it must be sufficiently stiff, have only small geometric deviations, and have suitable surface properties as required by the measuring method. The traceability can be ensured by measuring the standard on a traceable coordinate measuring machine (CMM). Fig. 1 shows the Leitz PMMF 30.20.7 from Hexagon Metrology GmbH at the large gear laboratory at BIMAQ.

An improved and reliable technology also includes the holistic measurement of the functional surfaces regarding geometry [3] and material properties [4]. Instead of an evaluation of the functional flank surface based on a few measuring lines areal information is acquired which lead to additional data on the gear quality [3]. This requires new fundamental knowledge in form of mathematical models for the description of flank form deviations and their uncertainty estimation.

Furthermore, sensors are developed for the measurement of surface properties (e.g. roughness, fracture detection) and for near-surface properties (e.g. hardness, detection of grinding burn, thermal damaging). Alongside the development of these sensors for an application in wind turbines, the research extends to possible further applications in the production process of drive train parts. This is supported by investigations regarding the optimization of the production process of large gears, integrating the conclusions from the measurement results.

For energy plants the use of systems for the continuous condition acquisition (Condition Monitoring System – CMS) is state of the art and allows for early reaction to malfunctions before larger damages occur. Actually, only few sensors for the application in wind energy gear boxes are widely used. Thus, another goal of the project is the development of optical sensors for



Figure 1: Leitz PMM-F 30.20.7 coordinate measuring machine at the Laboratory for large-scale gear-measurements (Source: BIMAQ)



Figure 2: Rotor head and shaft of a wind energy system (Source: BIMAQ)

the contactless acquisition of axial, radial and rotational movements on drive train components (e. g. fig. 2). Integrating these measurements in future CMS will improve the maintenance of wind turbines [5].

BIMAQ. Different aspects will be tested, proven and evaluated technically and economically by the project partners.

## Summary

The project establishes the prerequisites for a dependable quality measurement for individual drive train components, especially large gears. The activities of the project range from industrial basic research in the field of sensors and their handling, to pre-competitive developments with respect to process optimization, machine positioning, firmware and measurement software, operational concepts as well as handling and calibration of large gear standards. The interaction of machine hardware, sensors, machine control, workpiece handling, specially developed software and measurement strategies will be brought together on a CMM at the large gear laboratory at

## References

- [1] Goch, G.; Knapp, W.; Härtig, F.: Precision engineering for wind energy systems. *CIRP Annals - Manufacturing Technology* 61/II (2012), pp. 611-634.
- [2] Härtig, F.; Rost, K.; Goch, G.: Large gear material standard for the traceability of gears for transmission manufacturing. *VDI-Berichte*, Vol. 2108. VDI Verlag, Düsseldorf, 2010, pp. 991-1004.
- [3] Westerkamp, J. F.; Stöbener, D.; von Freyberg, A.; Fuhrmann, M.; Goch, G.: Auswertung flächenhafter Messungen an Großverzahnungen. *Proceedings XXV. Messtechnisches Symposium des Arbeitskreises der Hochschullehrer für Messtechnik e.V. (AHMT)*. Shaker Verlag, Aachen, 2011, pp. 299-310.
- [4] Kruse, D.; Prekel, H.; Goch, G.; Walther, H. G.: Correlation between hardening depth and thermal parameters based on photothermal measurements. *Proceedings of the estonian academy of science – Engineering* 13 (2007) 4, pp. 423-435.
- [5] Schuh, P.; Tracht, K.; Westerkamp, J. F.; Sorg, M.; Bredemeier, C.; Goch, G.: Zustandsorientierte Instandhaltung von Windenergieanlagen. *VDI-Berichte*, Vol. 2151. VDI-Verlag, Düsseldorf, 2011, pp. 33-34.

# Non-destructive and Reliable Real-time Detection of Thermal Damages in Grinding Processes

Universität Bremen  
Bremen Institute for Metrology,  
Automation and Quality Science (BIMAQ)  
(in cooperation with Friedrich-Wilhelm-  
Bessel Institute)

Philipp Thiemann<sup>1</sup>, Gerald Ströbel<sup>2</sup>

Friedrich-Wilhelm-Bessel Institute<sup>2</sup>  
Bremen Institute for Metrology,  
Automation and Quality Science

Funding:  
AiF within the programme  
"Joint Industrial Research" (IGF) funded  
by the Federal Ministry of Economics and  
Technology  
Ref.Nr. 17289N/1

Duration: 10/2011 – 03/2014

## Introduction

Mechanical components in powertrains of wind energy converters like gears or bearing rings have to be hardened due to the loads which impact on these parts. Afterwards, a grinding process, which may induce undesired material modifications, is necessary to maintain the geometric tolerances. The reliable and quantitative detection of these thermal defects, which are summarized under the term of grinding burn, is a current problem in the non-destructive material testing. Because of the disadvantages of the common testing methods like nital etching or micromagnetic measuring techniques, new methods have to be investigated. The research project examines the suitability of the laser-based photothermal radiometry for the qualitative and quantitative detection of grinding burn. The effects of different stages of grinding burn on the photothermal measurement signal are examined by simulations and experiments.

## Project Description

Grinding is one of the most important industrial cutting processes, especially for the manufacturing of high precision and highly stressed components. The grinding process induces heat and plastic strain within work pieces, which may cause an undesired material modification on and below their surfaces (Fig. 1). The non-destructive testing with respect to these thermo-mechanical defects is necessary to evaluate the functionality of the manufactured component [1]. Especially the production of large components for wind energy converters like gears or bearings requires the detection of grinding burn on large functional surfaces. The conversion from single piece production to series production additionally requires the automation of the measurement and profits significantly from the reduced measuring times of contactless measuring systems. This change requires an optimization of each step of the production process. Therefore, the performance of the essential grinding processes has to be improved, which increases the danger of grinding burn.

The term of grinding burn summarizes all kinds of thermal defects which lead to a reduced product lifetime. Examples of grinding burn are annealing zones or new hardened zones with an increase or a decrease of the material hardness close to the machined surfaces. Various testing methods are applied in the industry and in laboratories to check components for grinding burn. The most established method is nital etching. Here, a work piece is etched and cleaned repeatedly, which causes a change of surface color if grinding burn is involved. This method has disadvantages like the subjectivity because of the visual inspection or the pollution of the environment due to the use of acids. Other established testing methods are metallography, X-ray analyses or the analysis of the Barkhausen noise (Fig. 2). All testing methods have disadvantages in terms of the costs or expenses. So it is obvious that new testing methods have to be investigated [2, 3].

A new approach is provided by the photothermal radiometry, which is a non-destructive test method to determine the thermal properties of near surface zones. This

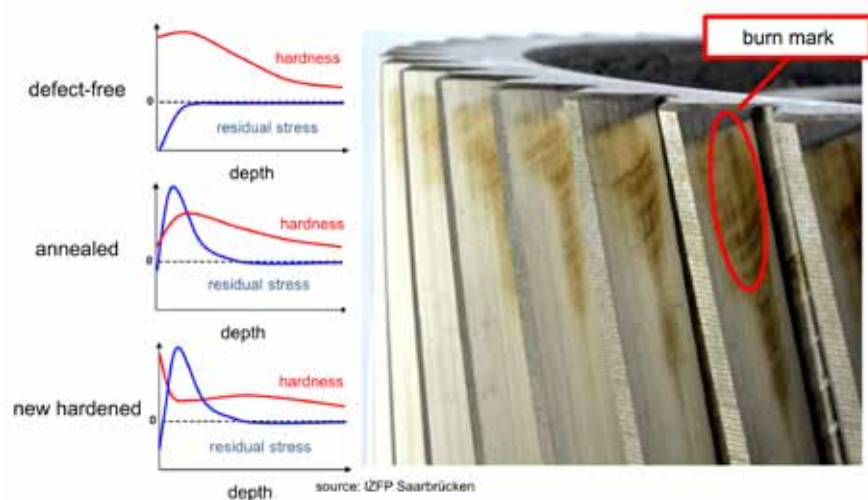

Figure 1: States of grinding burn

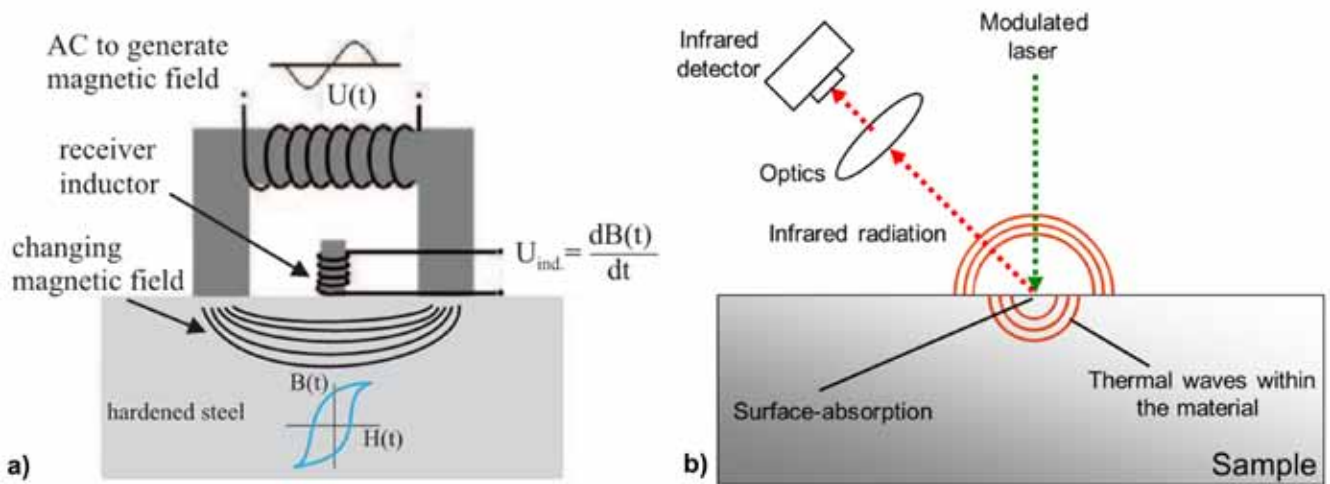

Figure 2: Non-destructive measurement principles [2] a) principle of the Barkhausen noise analysis b) photothermal measurement principle

technique bases on the generation and detection of thermal waves that interact with thermal inhomogeneities. For this purpose the material surface is periodically heated by a modulated laser. The modulation frequency determines the penetration depth of the thermal wave into the material. Local variations of thermal material parameters (thermal conductivity, heat capacity) disturb the propagation of thermal waves, causing reflections and scatterings which lead to detectable modifications of the temperature oscillation at the surface. This temperature oscillation is detected using infrared sensors. Material defects can be discovered by comparing the amplitude and, more impor-

tant, the phase of the infrared signal with those measured at homogeneous materials (Fig. 3). The photothermal technique is always a promising approach if certain material properties like hardness and residual stress correlate with thermal properties [3].

**Summary**

The research in the project “nondestructive and reliable real-time detection of thermal damages in grinding processes” will help implementing a 100%-quality inspection of ground components like gears or bearing rings. In contrast to the employed test-

ing methods the examined non-destructive measurements methods allow a fast, reliable and non-reactive testing of each manufactured component within highly stressed powertrains of wind energy converters.

*This IGF-project (17289N/1) of the Deutsche Forschungsvereinigung für Mess-, Regel- und Systemtechnik e.V. (DFMRS) is funded by the AiF within the programme „Joint Industrial Research“ (IGF) funded by the Federal Ministry of Economics and Technology.*

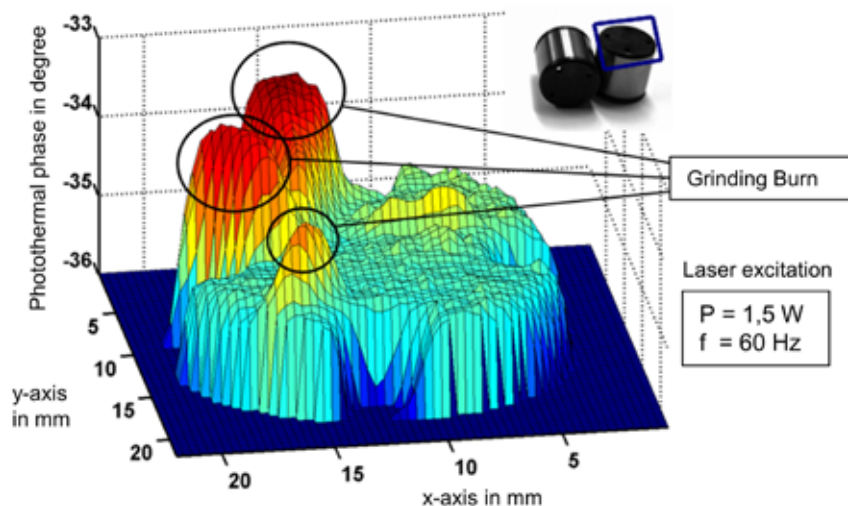

Figure 3: Result of a photothermal measurement on a thermally damaged component

**References**

- [1] Bausch, T.: Innovative Zahnradfertigung. Expert Verlag, Renningen, 2011.
- [2] Karpuschewski, B.; Bleicher, O.; Beutner, M.: Surface integrity inspection on gears using Barkhausen noise analysis, Procedia Engineering 19, pp. 162-171, Elsevier, Amsterdam, 2011.
- [3] Thiemann, P.; Kruse, D.; Goch, G.: Zerstörungsfreie Randzonenanalyse thermo-mechanisch geschädigter Bauteile mit photothermischen und mikromagnetischen Verfahren. In: Schmitt, R. (Hrsg.): XXVI. Messtechnischen Symposiums des Arbeitskreises der Hochschullehrer für Messtechnik e.V. (AHMT), Shaker Verlag, Aachen, 2012. - ISBN 978-3-8440-1312-2, pp. 93-104.

# Silicon Carbide Power Technology for Energy Efficient Devices (SPEED)

Leibniz Universität Hannover  
 Institute for Drive Systems and Power Electronics (IAL)

Axel Mertens, Robert Meyer,  
 Christian Sommer

Funding: European Union's Seventh Framework Programme for research, technological development and demonstration

Duration: 01/2014 – 12/2017

## Introduction

Highly efficient Power Electronics (PE) employed in power generation, transmission, and distribution is a prerequisite for the Europe-wide penetration of renewable energies. It improves the energy efficiency, increases the power quality and enables continuous voltage regulation, reactive power compensation and automated distribution. It also facilitates the integration of distributed resources like local energy storage, photovoltaic generators, and plug-in electric vehicles.

The development of a new generation of high power semiconductor devices, able to operate above 10kV, is crucial for reducing the cost of PE in the above-mentioned applications. The material properties of SiC, clearly superior to those of Si, will lead to enhanced power devices with much better performance than conventional Si devices. However, today's SiC PE performs rather poorly, compared to the predictions and the production costs are by far too high.

Pooling world-leading manufacturers and researchers, SPEED aims at a breakthrough in SiC technology along the whole supply chain:

- Growth of SiC substrates and epitaxial layers.
- Fabrication of power devices in the 1.7kV / >10kV range.
- Packaging and reliability testing.
- SiC-based highly efficient power conversion cells.
- Real-life applications and field tests in close cooperation with two market-leading manufacturers of high-voltage (HV) devices.

Known and new methodologies will be adapted to SiC devices and optimized to make them practicable. The main targets are cost-savings and excellent power quality using more efficient power converters that exploit the reduced power losses of SiC. To this end, suitable SiC substrates, epitaxial layers, and HV devices shall be developed and eventually be implemented in two demonstrators:

- A cost-efficient solid-state transformer to support advanced grid smartness and power quality.
- A windmill power converter with improved capabilities for generating AC and DC power.

## Project Description

The role of IAL is focused on the design and development of power electronic concepts for future windmill power converters. Compared to conventional Si semiconductors, SiC semiconductors are characterized by higher efficiency and lower costs for grid filters [1,2]. However, SiC components are

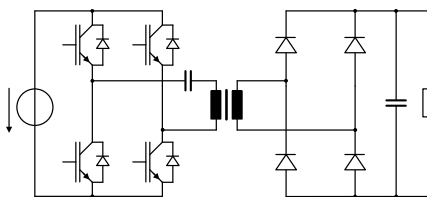

Figure 1: Single-phase SRC

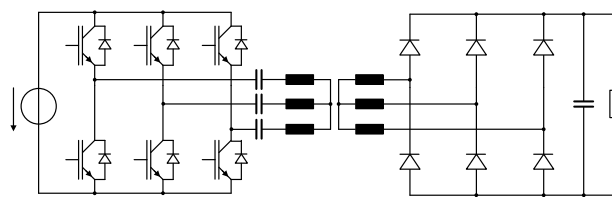

Figure 2: Three-phase SRC

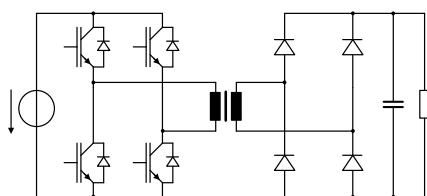

Figure 3: Single-phase Single Active Bridge

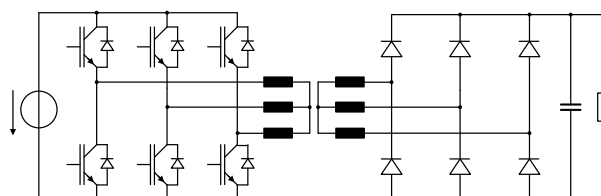

Figure 4: Three-phase Single Active Bridge



not yet available in the high-power class required for wind power converters. For this reason, SiC power semiconductor devices and modules to be applied in wind turbines are developed in this project. At IAL, converter topologies for wind turbines are under investigation which, combined with the benefits of SiC technology, may improve system efficiency to a considerable extent. Special emphasis will be placed on DC/DC solutions, which are considered as the future trend for grid-side connection [3,4].

A literature study on high power DC/DC converters was done in order to select promising topologies [5,6]. The focus is laid on unidirectional converters, since for the windmill the power flow is from the turbine to the grid, except for low reverse power flow in black start situations. Resonant converter topologies, like the series resonant converter in single-phase (Fig. 1) and in three-phase configuration (Fig. 2), are of interest when regarding high power converters.

However, the disadvantages of these topologies are the limited operation range due to the soft switching requirement, as well as the need for high-voltage/high-current resonant capacitors which could also affect the reliability of those converters. For this reason, the effort and interest at this stage of the project is focused on non-resonant converters like the single-phase (Fig. 3) and three-phase (Fig. 4) single active bridge [7,8].

Device losses for the baseline IGBT module and the hybrid module (Si-IGBT and SiC-Diode) were investigated experimentally, and compared with SiC-MOSFETs for these topologies.

Fig. 5 depicts simulation results that show the superiority of SiC compared to Si and hybrid module over the entire power range for the Three-phase Single Active Bridge (The switching frequency is constant for each device). Besides the DC/DC converters, AC/DC converters will also be analyzed because of their importance in generator side power conversion. Finally, systems interaction and system optimization will also be considered.

## Summary

This FP-7 project focuses on the development of new power semiconductor devices made from Silicon Carbide (SiC) that open the way to novel concepts and applications in the high power range, such as renewable energies, traction, power generation and distribution. At the Institute for Drive System and Power Electronics, the application in high power converter topologies for future offshore wind turbines connecting to an offshore DC voltage grid are investigated. The results will be used to select and design a demonstrator that will be built by industry partner INGETEAM in this project.

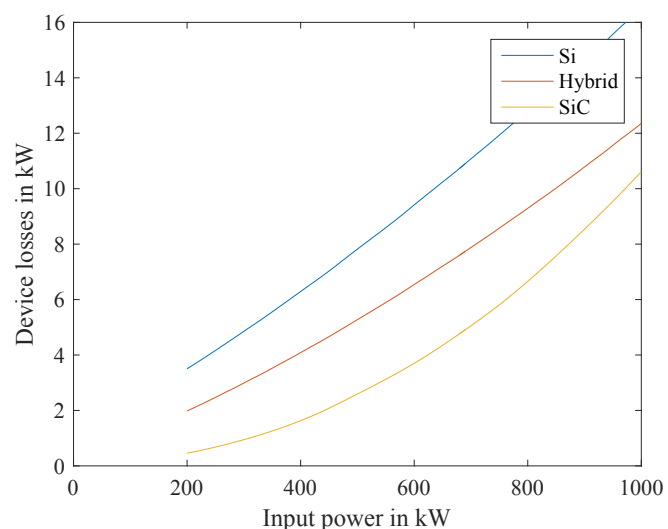

Figure 5: Device losses of different devices for the Three-phase Single Active Bridge

## References

- [1] Zhang, H., & Tolbert, L. M.: Efficiency impact of silicon carbide power electronics for modern wind turbine full scale frequency converter. Industrial, 2011
- [2] Biela, J., Schweizer, M., Waffler, S., & Kolar, J. W.: SiC versus Si- Evaluation of potentials for performance improvement of inverter and DC-DC converter systems by SiC power semiconductors. Industrial Electronics, IEEE Transactions on, 58(7), pp. 2872-2882, 2011
- [3] Blaabjerg, F., & Ma, K.: Future on power electronics for wind turbine systems. Emerging and Selected Topics in Power Electronics, IEEE Journal of, 1(3), pp. 139-152, 2013
- [4] Meyer, C.: Key components for future offshore dc grids. Shaker, 2007
- [5] De Doncker, R. W., Divan, D. M., & Kheraluwala, M. H.: A three-phase soft-switched high-power-density DC/DC converter for high-power applications. Industry Applications, IEEE Transactions on, 27(1), pp. 63-73, 1991
- [6] Kheraluwala, M. H.: High-power high-frequency dc-to-dc converters. Wisconsin Univ., Madison, WI (United States), 1991
- [7] Max, L., & Lundberg, S.: System efficiency of a DC/DC converterbased wind farm. Wind Energy, 11(1), pp. 109-120, 2008
- [8] Ortiz, G., Biela, J., Bortis, D., & Kolar, J. W.: 1 Megawatt, 20 kHz, isolated, bidirectional 12kV to 1.2 kV DC-DC converter for renewable energy applications. In Power Electronics Conference (IPEC), 2010 International, pp. 3212-3219, IEEE, June 2010

# Silicon Carbide Power Technology for Energy Efficient Devices (SPEED)

Universität Bremen  
Institute for Electric Drives, Power  
Electronics and Devices (IALB)

Felix Hoffmann, Nando Kaminski

Funding: Seventh Framework Programme,  
European Commission  
Ref.Nr. 604057

Duration: 01/2014 – 12/2017

## Introduction

The development of a new generation of high power semiconductor devices, able to operate above 10 kV, is crucial for reducing the cost of PE for power transmission and renewable energies. The material properties of SiC clearly are superior to those of Si for high voltage devices. Pooling world-leading manufacturers and researchers, SPEED aims at a breakthrough in SiC technology along the whole supply chain:

- Growth of SiC substrates and epitaxial-layers.
- Fabrication of power devices in the 1.7/>10 kV range.
- Packaging and reliability testing.
- SiC-based highly efficient power conversion cells.
- Real-life applications and field-tests in close cooperation with two market-leading manufacturers of high-voltage (HV) devices.

The main targets are cost-savings and superior power quality using more efficient power converters that exploit the reduced power losses of SiC. To this end, suitable SiC substrates, epitaxial-layers, and HV devices shall be developed and implemented in two demonstrators, a solid-state transformer and a windmill power converter.

Within the scope of this project, the core responsibility of IALB is reliability testing and analysis of SiC devices. For details about the SPEED project see [1].

## Project Description

Reliability is a major concern for power systems design and particularly the operating life of semiconductor devices is crucial for overall lifetime estimation. For this reason, reliability tests such as power cycling, temperature cycling and climate tests are conducted within the scope of this project.

The work presented here is focused on power cycling. For this test procedure the device under test (DUT) is heated up by means of on-state power dissipation. Once the desired maximum junction temperature is reached, the load current is turned off and the junction cools down to the desired minimum temperature. These cycles are repeated until the DUT fails. By conducting several IOL tests with varying middle temperature  $T_{v,m}$  and temperature swing  $\Delta T_{vj}$ , the Coffin-Manson lifetime model parameters can be obtained. The Coffin-Manson model for power semiconductor devices describes the mean time to failure of a device in dependence to its junction temperature swing and middle temperature. It originates from the theory of low cycle fatigue of mechanical

materials under stress high enough to induce plastic deformation. The intermittent operational life (IOL) can be calculated by considering the mission profile and projecting the consequential thermal parameter on the Coffin-Manson model.

At IALB, a power cycling test bench for discrete devices has been developed. The test bench consists of two test lanes which provide forced air cooling with a specific air temperature for all DUTs. The Airflow is self-contained and the temperature is controlled by means of a heating system and a recuperator. Fig. 1 shows the concept of a single test lane.

For the analysis of power cycling tests, the minimum and maximum junction temperatures have to be determined very precisely as the resulting cycles to failure are strongly depending on the junction temperature swing. However, since the junction temperature is not accessible for direct measurement, it has to be determined indirectly, i.e. through the temperature dependence of a well measurable parameter. For power cycling tests, the temperature dependence of the on-state voltage for small load currents has been proven an appropriate method [2]. As for all indirect measurement methods, a calibration has to be conducted. The DUT is heated up in an oven to its maximum operating temperature and subsequently cooled

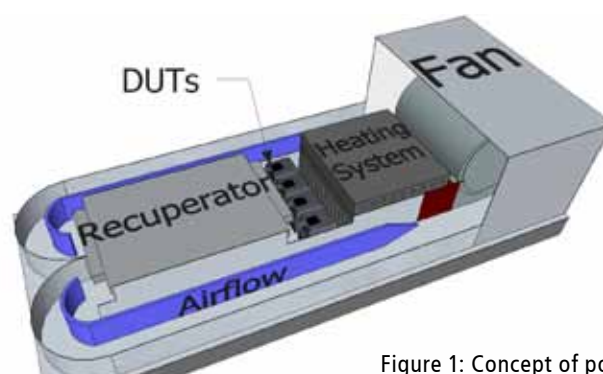

Figure 1: Concept of power cycling test lane

down slowly. Both, case temperature and on-state voltage at a specific load current, are logged. For common measurement currents in the range of 0.1% of the rated nominal current, self-heating through the on-state losses is negligible and, therefore, the case temperature is the same as the junction temperature. Fig. 2 shows the temperature characteristics of a silicon IGBT. In order to proof the general concept and functionality the first test batches are silicon devices due to the availability of reference data.

According to the measurements there is a good correlation in the investigated temperature range between the junction temperature and the forward voltage drop for small currents and, hence, it is a good parameter for indirect measurement.

Fig. 3 shows the  $V_{CE}$  characteristics for a single power cycle. During the cooling phase, the load current is switched off and only the measurement current is forced through the DUTs. The on-state voltage is easily correlated to the junction temperature with the curve obtained during the calibration measurement. However, for the first couple of microseconds after the load current is turned off, the on-state voltage is subject to oscillations. For this timespan, commonly referred to as recombination time, the measured voltage does not represent the actual voltage dependent on the junction temperature. In order to obtain higher accuracy for the maximum junction temperature, the on-state characteristics is fitted with the square root time method after the oscillation has faded (see Fig. 4) and the minimum on-state voltage at the time of the switching event is then calculated according to the fit [3].

Fig. 5 shows the cooling curve. In addition to obtaining the minimum and maximum junction temperature, the logarithmic scaled cooling curve is directly proportional to the thermal impedance of the DUTs thermal path and, therefore, changes in the interconnection of the thermal layers can be monitored. This can be used to analyse weak spots and degradation processes in the thermal path.

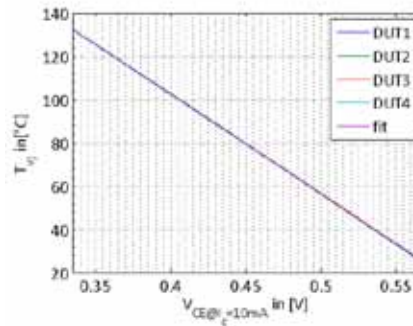

Figure 2:  $T_j = f(V_{CE}^on)$  characteristics of an IR4PC50FD IGBT

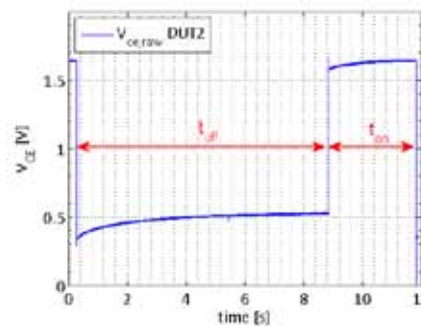

Figure 3:  $V_{CE}$  characteristics for a single power cycle

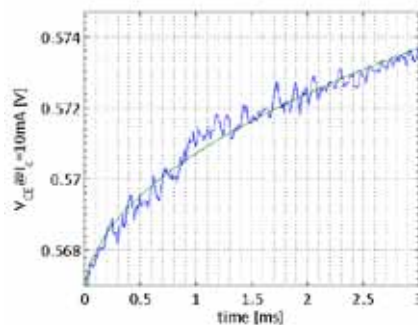

Figure 4: Square root time fit for the cooling curve

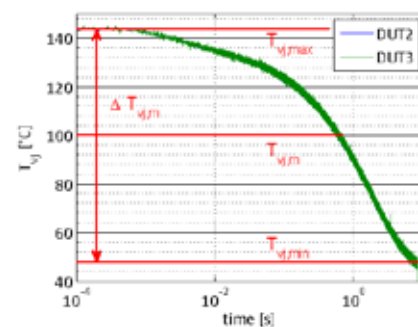

Figure 5: Cooling curve in logarithmic scale

Once the load current is switched on, the on-state voltage increases to the nominal value of the load current. Since the on-state voltage temperature dependence changes from NTC to PTC behaviour for higher currents, the voltage increases with higher temperature during the heating phase.

### Summary

Lifetime and reliability analyses are important factors for power semiconductor devices. For silicon devices plenty of field data and research studies are readily available. Hence, end of life failure modes and possible weak spots are known and well controlled. However, for relatively new materials and silicon carbide in particular data is still comparatively rare. New failure modes are possibly occurring and lifetime models might have to be adjusted. The ongoing research activities at IALB aim for reliability data and lifetime models of the silicon carbide devices developed within the SPEED project.

### References

- [1] [www.speed-fp7.org](http://www.speed-fp7.org)
- [2] Hensler, Alexander: Improving the accuracy of junction temperature measurement with the square-root-t method, THERMINIC 19th International Workshop 2013
- [3] Blackburn, D.L.: An Electrical Technique for the Measurement of the Peak Junction Temperature of Power Transistors, Reliability Physics Symposium, 13th Annual report 1975

# GeCoLab – 1.2 MW Test Bench for Generators and Converters

Leibniz Universität Hannover  
Institute for Drive Systems and Power  
Electronics (IAL)

Bernd Ponick, Axel Mertens

Funding: Federal Ministry for the  
Environment, Nature Conservation, Build-  
ing and Nuclear Safety (BMUB)  
Ref.Nr. 0325398

Duration: 01/2012 – 12/2015

## Introduction

In the next decades, new wind turbines will be more and more developed for offshore applications. In 2009, 37,773 GWh of power was generated in Germany by on-shore wind turbines, whereas the output of offshore turbines was just about 37 GWh. These figures prove that the expansion of offshore wind power capacity has only just started. More offshore applications will increase the capacity of each individual system; next-generation system capacities will be in the range of 8 to 10 MW. The trend is towards gearless direct drive and full converter concepts, going along with enhanced use of medium-voltage technology in wind turbines and thus with changed generator and converter concepts. In this respect, special requirements concerning reliability and maintainability have to be taken into consideration. In German wind energy research, there exists up to now no universal test bench which is suitable for testing pre-production samples at a pre-competitive stage.

## Project Description

The demands on generator/converter systems especially when used in wind turbines have changed during the last years. Due to the vast increase of installed power of distributed energy supplies, today's large-scale energy generation systems must imperatively guarantee grid support and fault ride-through. These changes have a direct influence on the choice of the generator/converter system as well as on the control concepts required.

Funded by BMUB, a large-scale test facility is under construction at IAL, designed for researching and testing converter and generator concepts including a converter-integrated control on a scale of about 1:10. Possible work also includes investigations on dynamics and system stability, stationary and transient thermal load, various grid supply methods as well as the behavior in case of grid failures, e.g. voltage dips, phase-to-phase faults or ground faults. Moreover, the interactions between converter and generator and their influence on other system components like bearings and gears shall be investigated. These are e.g. the effects of current and voltage harmonics, additional losses, local saturation effects as well as bearing voltages and currents. The verification of enhanced simulation models for electrical and mechanical components involved as well as filter design methods will also be a subject of research.

Due to its size and performance, the test bench is not erected directly at IAL, but in a newly constructed building, the "Test Center for Support Structures" at Hannover-Marienwerder, and is accompanied by two other large-scale test benches under the guidance of some civil engineering institutes. Construction started in autumn 2012, its completion is planned for 31st March 2014. Then the electrotechnical test

equipment worth about 3 million € will be installed. Testing is scheduled for the first half of 2015.

The GeCoLab test hall has a building area of 113 m<sup>2</sup> and a height of 8.50 m. Two adjacent rooms serve as control and evaluation room as well as for preparatory work. The test hall entrances dimensions are 4 m x 4.5 m. That way large-scale components of up to 20 t can be moved into the hall to be positioned by the hall crane on the span. The span has an area of 10 m x 4.30 m and a net weight of about 70 t. The span is supported by air spring elements with a natural frequency of approx. 2 Hz.

In the original equipment, a high-speed doubly fed induction machine (DFIG) and a low-speed permanent magnet synchronous machine (PMSM) with 690 V each are coupled by an adapter gearing. The machines can be supplied by separate converters. The DFIG is fed by a modified standard wind turbine generator, whereas the PMSM is fed by a high-performance full converter. Using a grid-simulating converter, arbitrary faults can be imposed on the machines and their converters on the grid side. The converter transformers connected downstream are used to improve the voltage curve at the output of the grid simulator. For investigations in a wider frequency range, transformers can also be abandoned, provided that a higher THD is acceptable in this case.

The test bench is designed for a feed-in power of 1.25 MVA. About 20 running meter of switch cabinets required for the converter equipment and two converter transformers will be set up in the test hall. The effective length of power cables (NYCWY 3x185/95 mm<sup>2</sup>) will amount to approx. 3 km, equal to nearly 25 t copper weight. The system diagram (see Fig.) gives an impression on the universal possibilities offered by the test facility, and this not only for the

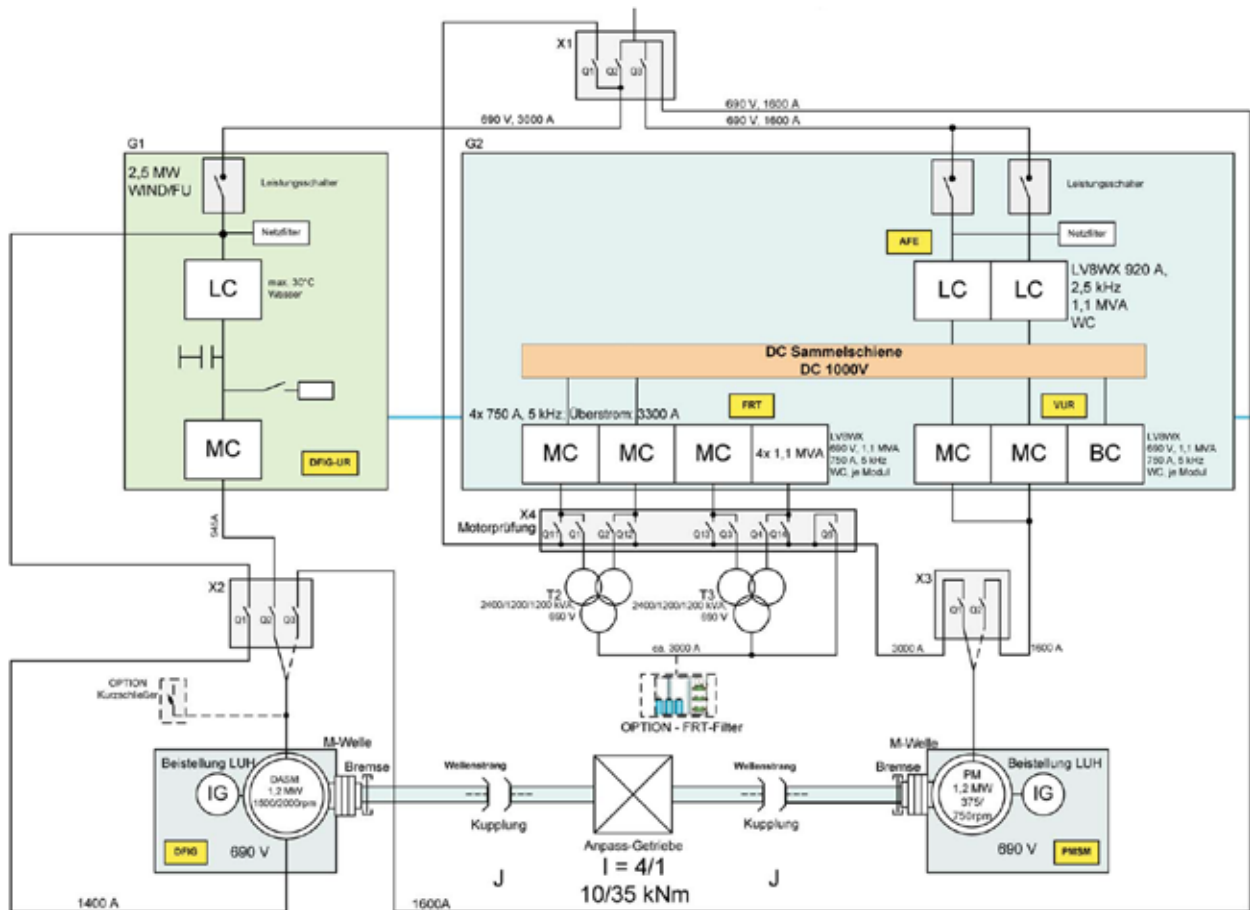

Figure 1: GeCoLab system diagram

test machines and converters specifically equipped for testing, but also for specimens, be it machines or converters, provided by customers.

## Summary

The completed test bench will be a unique test facility for fundamental research on various generator-converter concepts as well as for versatile laboratory tests instead of field tests performed on wind turbines.

## References

[1] [www.tth.uni-hannover.de](http://www.tth.uni-hannover.de)

# Probabilistic Safety Assessment of Offshore Wind Turbines

Leibniz Universität Hannover  
All institutes are members of ForWind and belong to the Leibniz Universität Hannover:

Institute of Concrete Construction  
Steffen Marx / Michael Hansen  
(Coordination),  
Institute of Building Materials Science  
Ludger Lohaus,  
Franzius Institute of Hydraulics,  
Waterways and Coastal Engineering  
Torsten Schlurmann,  
Institute for Geotechnical Engineering  
Martin Achmus ,  
Institute for Steel Construction  
Ing. Peter Schaumann,  
Institute of Structural Analysis  
Raimund Rolfes,  
Institute for Drive Systems and Power  
Electronics  
Axel Mertens / Bernd Ponick,  
Institute of Electric Power Systems  
Lutz Hofmann,  
Institute for Machine Design and Tribology  
Gerhard Poll,  
Insitute of Turbomachinery and Fluid  
Dynamics  
Jörg Seume

Funding:  
Ministry for Science and Culture in Lower  
Saxony  
Support Code: GZZM2547

Duration: 12/2009 – 11/2014



The ForWind research project Probabilistic Safety Assessment of Offshore Wind Turbines (PSA OWT) is sponsored by the Ministry for Science and Culture in Lower Saxony since 1.12.2009. In this research project safety assessments of the support structure and specific electrical and mechanical components of Offshore Wind Turbines (OWT) are performed. Since 2010 project descriptions, objective targets and research results are documented in annual reports which are available on [www.psb.uni-hannover.de](http://www.psb.uni-hannover.de). PSB Annual Report 2013 contains assumptions, aims and outcomes for several examinations concerning parts of OWT in view of civil engineering, mechanical engineering and electrical engineering. In spring 2015 the whole works of this project will be summarized in the Final Report.

## Project Description

Within this research project in several work packages (WP) a wide variety of topics concerning probabilistic methods are analysed. These methods and further correlations partially were described in WP 1 in former annual reports. Furthermore, connections between the involved institutes and their treated subjects are shown in this coordinating WP1.

Extreme hydrodynamic loads on OWTs result from breaking waves, which cause severe impact on offshore structures and induce significant singular stresses as well as vibration and therefore discrete degradation of the support structure. For an efficient design of OWTs, dominant and significant sea state parameters as well as wave-breaking probabilities must be considered. This work is done in the first part of WP2. In the first step design wave heights and occurrence of wave trains in the North Sea have been analysed on the basis of statistical analysis of extreme events. The second step

deals with the wave-breaking probability, which is investigated by means of laboratory experiments in two-dimensions to quantify the scatter of the influencing factors, i.e. significant wave height  $H_S$ , peak period  $T_P$ , random phase angle  $\phi$  and water depth  $d$ . The laboratory experiments show a significant influence of the random phase angle, i.e. wave sequence in the time series, on the wave-breaking probability, which has to be investigated in depth in further test runs.

In the second part of WP2 wind forces are examined. In addition to the complex flow environment and the geometric deviations, structural imperfections of rotor blades are one of the main sources of uncertainties in wind turbine design. These can arise due to imperfections of the composite materials, which can be caused by variations of the fiber and matrix material properties and the fiber volume ratio etc. Structural uncertainties can also arise due to tolerances in the non-automated manufacturing process. In order to investigate the effect of structural uncertainties on the full-system mode shapes and natural frequencies of an offshore wind turbine (OWT), the distributed blade mass density and the cross-sectional flapwise and edgewise stiffness are varied relatively with respect to the corresponding baseline parameters. The variations of the spatially correlated structural properties are modeled by a random field approach. The results show a significant scatter of the natural frequencies of the rotor modes and the torsional drivetrain mode which can lead to an increased risk for resonances with the 3P harmonics of the rotational speed.

WP 3 deals with the calculation of partial safety factors for mainly axially loaded offshore foundation piles. Therefore a case study of a Reliability Based Design for two common soil profiles and two design methods, the API-method and the ICP-method, was performed. Moreover a cali-

bration of partial safety factors was carried out to match the safety requirements of the Eurocode 0. According to the computed results the partial safety factors should be decreased for the API-method, where an increase for the ICP-method seems to be suitable. Thereby also a more accurate determination of the required embedded pile length was achieved compared to deterministic design.

The foundation and support structures of OWT are examined in WP4. Reliability analyses are carried out for a monopile and jacket structure. Limit states which are critical for the structural design of OWTs are identified. On basis of the ultimate limit state as defined by valid standards, extreme events as well as the statistical properties of the resulting loads acting on substructures are investigated. Especially the scattering of the environmental conditions which describe the sea state and wind fields are considered within the ongoing research. Also, the correlation between parameters has to be taken into account for the probabilistic design. Different methods such as the Monte-Carlo simulation can be applied in order to determine the probability of failure for scattering parameters. In addition, the fatigue limit state has to be considered for branched structures such as jackets and tripods. Here, the fatigue damage is investigated concerning its statistical properties. In WP 5 risk factors of grouted joints during the execution process are investigated by using methods like Preliminary Hazard Analysis (PHA) and Fault Tree Analysis (FTA). First, supporting structures and typical offshore boundary conditions were analysed. To perform a detailed PHA, the different commonly used supporting structures under typical offshore conditions were analysed according to the load bearing behaviour. Based on the findings of the PHA, different failure modes of the grouting process were simulated using several laboratory testing facilities. These tests simulate possible adverse effects and their influence on the strength of the hardened grout material. In a subsequent FTA, the main risk factors according to the load bearing capacity of the grouted joint will be identified. The findings will be used to

develop recommendations to minimise the risk for possible defects of the grouted connection.

Drive trains of wind power plants contain different mechanical components with limited lifetimes which can only be estimated as a probability for selected fundamental failures. For example, rolling element bearings are exposed to operation conditions causing damage mechanism that aren't fully investigated yet and that are therefore not included in common calculations of bearing lifetime. To nevertheless ensure a high availability and low maintenance costs, maintenance has to be planned early and effective, especially for hard to reach OWT, by an early recognition of failures during operation. WP6 therefore deals with the development and testing of condition monitoring systems for large size rolling element bearings. The measurement of vibration signals emitted by a repetitive overrolling of failures in the raceways of rolling element bearings and a novel method for signal analysis and evaluation are tested on a large size bearing test rig as well as on a real wind turbine.

WP7 focuses on the online fault detection in electrical machines using search coil systems. All important types of faults and damages in electrical machines result in characteristic changes of the magnetic air-gap field. These changes can be used to detect a fault by search coils placed in the stator slots based on the voltage induced in them to identify the type of fault in dependence of the frequency. Search coil systems are especially suitable for the detection of interturn faults and eccentricities, since these faults have no or little influence on the quantities at the terminals of a machine and are therefore not easy to be detected from the outside. Based on previous researches of search coil systems for synchronous machines, the special challenges of the design of search coil systems for permanent magnet synchronous machines with high pole pair/slot number combinations are determined. In this respect different approaches for the design of search coil systems are presented. Furthermore, design rules for search coil systems in multi-pole

permanent magnet synchronous machines are developed.

The converter lifetime of wind turbines is addressed in the first part of WP 8. Lifetime simulation models have been built. In 2013 they have been extended to dynamic operation mode and a complete simulation model was built. Real wind speed characteristics are integrated in the model. The thermal behaviour of the power electronics is modelled. First results show the dynamic thermal load of the converters for real wind speed steps.

For a reliability analysis of grid connections of offshore wind farms, different grid topologies and grid structures are analyzed and evaluated concerning their reliability in the second part of WP 8. On this occasion the uppermost purpose is to determine which grid topology owns the highest reliability. As input quantities for the reliability analysis of wind farm connections, characteristic reliability parameters of electrical components like transformers, cables etc. are considered. A model for probabilistic analysis for probabilistic reliability analysis for the entire wind farms including the grid connection was created. This model performs simulations under variation of reliability parameters. Thus potential weaknesses of grid connections are identified. But also profit calculations and location assessments are possible.

# OWEA Loads – Probabilistic Loads Description, Monitoring and Reduction for the Next Generation of Offshore Wind Energy Converters

Carl von Ossietzky Universität Oldenburg  
Institute of Physics,  
Wind Energy Systems, Turbulence, Wind  
Energy and Stochastics,  
Energy Meteorology

Martin Kühn, Joachim Peinke,  
Gerald Steinfeld, Matthias Wächter,  
Pedro G. Lind, Francesco Perrone, Hauke  
Wurps, Jens Tambke

Partners: SWE University of Stuttgart,  
Senvion SE, AREVA Wind GmbH

Funding: Federal Ministry for Economic  
Affairs and Energy (BMWi)  
Ref.Nr. 0325577B

Duration: 11/2012 – 11/2015

## Introduction

OWEA Loads aims to ascertain the relevant aspects concerning the aerodynamic, hydrodynamic and operational loads an offshore wind energy converter will face throughout its lifespan, with focus on the Rotor-Nacelle-Assembly (RNA). The project wants to convey a decisive impulse to the development of the new generation of offshore wind turbines. On one hand, the already available load measurements at Alpha Ventus may still be valuable for answering still pending research questions; on the other hand, novel and yet unexplored approaches will be considered in the areas of measurements, design and meteorology.

In the area of control, the design of several control methods to reduce severe loads will take place. Based on this analysis, it will be possible to define and clarify the set of needed requirements for the design of the future wind turbines.

Secondly, it will be paramount to assess the reliability of the already available load and strain measurements at Alpha Ventus, to prove the consistency of the ongoing experimental studies and, furthermore, possibly validate the measurements against numerical results.

Regarding meteorology, a new measurement campaign will allow for a better understanding of the environmental conditions an offshore wind turbine is likely to undergo. The collected data will serve, among others, the modelling and calculation of the wind profile as a function of the height; this will then be part of the load assumptions.

The project is a co-operation with the University of Stuttgart, AREVA Wind GmbH and Senvion SE.

## Project Description

### Control

Control plays a vital role in offshore wind energy applications, due to the particularly harsh combination of wind and sea conditions. Secondly, the diversity of currently available support structures on the market poses a higher degree of complexity. Therefore, it is particularly rewarding to design an effective control system, tailored to reduce loads and ensure sufficient quality standards in terms of both system safety and power output. As a general purpose, it would be of great advantage disposing of a control system able to adapt its behavior depending on the ongoing operational conditions. A possible interesting solution is to couple the control systems with the condition monitoring system: in this scenario, the best combination of control methods will be active only when the condition

monitoring system retrieves an alert. By means of such an integrated module, it will be possible to extend the lifetime of critical components such as the pitch actuators, while reducing loads and lowering needs for unscheduled maintenance. The so far collected results clearly show the potential of such a technique.

### Meteorology

On a first step, the ability of the Weather Research and Forecasting Model (WRF) to describe the wind conditions in the lower atmosphere over the North Sea has been validated: hence, several planetary boundary layer (PBL) schemes using diverse meteorological data as boundary conditions were compared. The quality of the boundary conditions strongly differ among meteorological re-analyses [1] and thus influence the performance of PBL schemes: the major source of error is introduced by the driving boundary conditions and not by the different meso-scale models.

Secondly, the analysis focuses on the turbulent kinetic energy (TKE) and the atmosphere's thermal stability are important to estimate power production and loads. The TKE is of especial interest because the Master Length Scale of some closure schemes show a TKE-dependency. Therefore, the results deriving from wind measurements have been validated. Because the considered heights are larger than available data from offshore met-masts, LiDAR observations and higher onshore met-masts data were also employed. The next goal is applying the WRF model to determine the wind conditions at sites without measurements.

### Stochastic processes

The framework of this project has been borrowed from statistical physics and



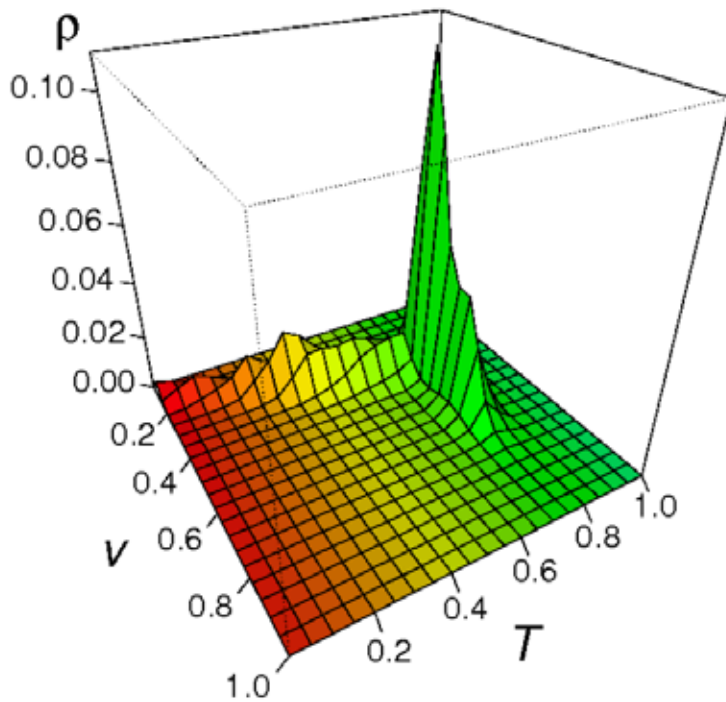

Figure 1: Wind speed – torque joint probability density function

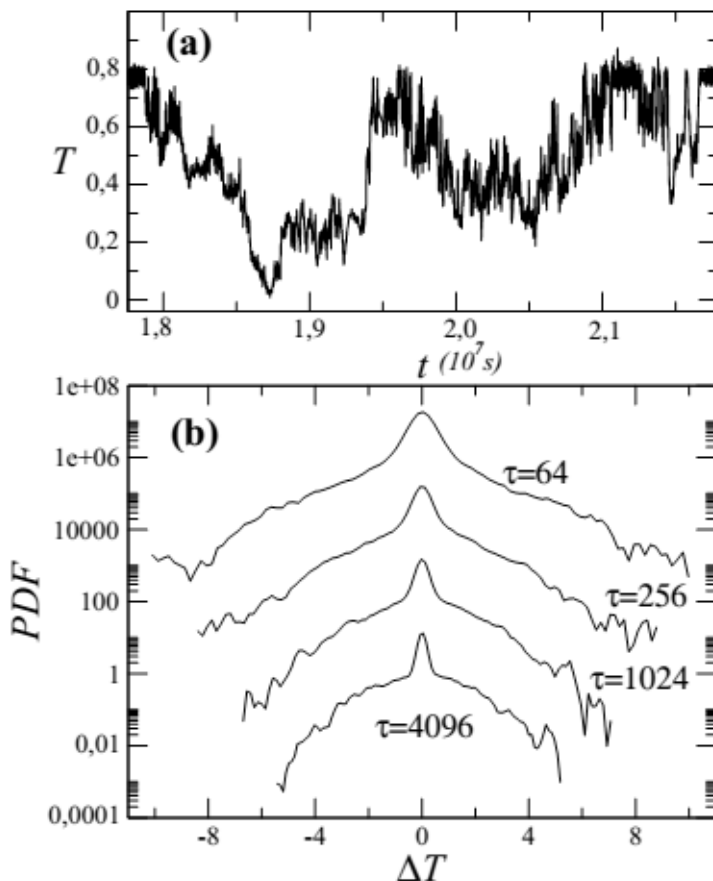

Figure 2: Torque time series and its incremental distribution

properly adapted to the analysis of multivariate data comprising wind velocity, power production and load measurements, taken at a single WEC. During 2013 (September-December) we prepared the data from Senvion's single WECs in the offshore Wind Farm Alpha Ventus and analyze its main statistical properties, namely the joint probability density function (PDF) for both wind speed and torque (see Fig. 1) and the torque increment distributions computed for different time-lags  $\tau$  (see Fig. 2). From the empirical PDF it will be now possible to derive the evolution equation of the torque, constrained to the observed wind speed, enabling to reconstruct the torque time-series and increment statistics.

### Summary

Scope of the project OWEA Loads is to supply the required parameters for the design of the next generation of offshore wind turbines. The analysis will span several fields of expertise. The integration of new and advanced control methods to both alleviate severe load configurations and reduce material expenditure; the further development of novel models to integrate the load assumption requirements. Finally, the in-depth assessment and validation of load and strain measurements, in order to achieve a more consistent insight of the actual condition an offshore wind turbine experiences while operation.

### References

- [1] R.Grotjahn, "Different data, different general circulations? A comparison of selected fields in NCEP/DOE AMIP-II and ECMWF ERA-40 reanalyses." Dynamics of Atmospheres and Oceans 44.3 (2008): 108-142.

# “Baltic I”: Control of Offshore Wind Farms by Local Wind Power Prediction as well as by Power and Load Monitoring

Carl von Ossietzky Universität Oldenburg  
Institute of Physics, Wind Energy Systems  
(coordination); Energy Meteorology;  
Turbulence, Wind Energy and Stochastics

Lueder von Bremen, Martin Dörenkämper,  
Detlev Heinemann, Constantin Junk,  
Martin Kühn, Anna Mehrens,  
Patrick Milan, Philip Rinn,  
Gerald Steinfeld, Jens Tambke,  
Juan Jose Trujillo, Luis Vera-Tudela,  
Matthias Wächter, Björn Witha

Partners: Stuttgart Wind Energy (SWE),  
University of Stuttgart;  
EnBW Erneuerbare und Konventionelle  
Erzeugung AG, Stuttgart

Funding: Federal Ministry for Economic  
Affairs and Energy (BMWi)  
Ref.Nr. 0325215A

Duration: 03/2011 – 11/2014

## Introduction

The research project Baltic I focused on an improved operation of offshore wind farms, which is achieved by the enhancement of power and load monitoring, wind power predictions and by new strategies for operational management of individual wind turbines and whole wind farms.

The research project was carried on the first commercial offshore wind farm in Germany “EnBW Baltic 1”, which is formed by 21 Siemens 2.3-93 wind turbines, located north of the peninsula ‘Darß-Zingst’ in the Baltic Sea. The location and layout of the wind farm provided interesting conditions, since its short distance to the coastline allows, from a scientific point of view, studying land-see flow interaction and its triangle-shaped layout creates different wake propagation scenarios.

## Project Description

### Power output monitoring

The Baltic Sea region is characterized by an interaction of onshore and offshore wind conditions, which results in a domination of stable atmospheric stratification due to high latitudes. Within the project, the coastal wind regime in the Baltic Sea has been investigated in more detail using the Weather Research & Forecasting (WRF) model. A hub height wind field during stable stratification obtained from these simulations is shown in Fig. 1.

The wind field reveals streaks which originate in local changes of the land use (e.g. forest alternating with farm land) and corresponding roughness length differences close to the coastline. Slight changes in wind directions can then lead to advection towards the wind farm location and hence strong wind power fluctuations, which can be recognised in the power output of the wind farm [1].

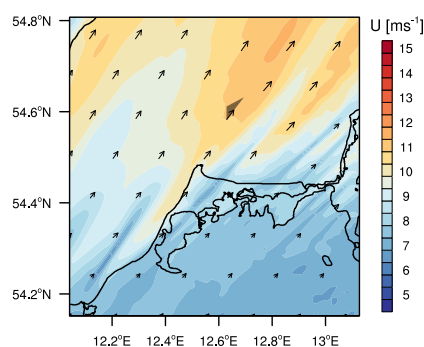

Figure 1: Hub height wind field from WRF simulations during stable atmospheric stratification on July, 23rd, 2012 – 1200UTC. The extension of the “EnBW Baltic 1” wind farm is indicated by the grey triangle

### Load Monitoring

Despite its importance, loading history of individual turbines is usually not recorded during operation due to its high costs. Therefore, predicting fatigue loads using only statistics of standard SCADA signals has been investigated using various data mining techniques, i.e. multilinear regression, neural networks, K-nearest neighbors. The selection of predictors is a major challenge in such data driven modeling. Vera-Tudela and Kühn [2] systematically analyzed potential input variables with filtering, clustering, stepwise regression and principal component analysis (May, 2011). More than 100 variables have been used to estimate the damage equivalent load of the blade root out-of-plane bending moment, as displayed in Fig. 2. As a result, the high variability of inputs selected in previous research could be explained and the authors were able to make similar predictions using only nine input variables: wind speed (mean (m) and standard deviation (sd)), electrical power (m), generator rotation (m), nacelle side-side acceleration (sd), nacelle fore-aft acceleration (sd), pitch angle (m, minimum and maximum). The results lead to a more robust, yet simpler load monitoring system.

Wind power prediction and grid integration  
Accurate wind power forecasts are an important aspect for trading wind power on the energy market. In addition to single-valued deterministic forecasts, probabilistic forecasts provide estimates of the forecast uncertainty, which lead to more value for the operational management of a wind farm.

Raw ensemble wind forecasts from ensemble prediction systems are subject to forecast biases and unreliable forecast uncertainties. As highlighted by Junk et al. [3], the bivariate adaptive wind vector calibration (AUV) is a promising calibration method that improves the reliability of the

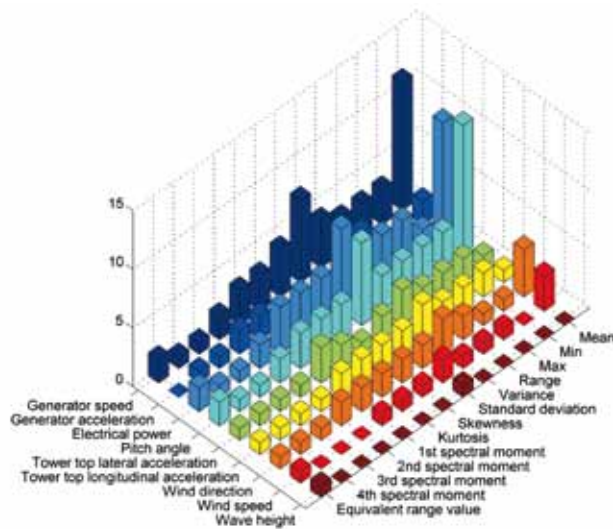

Figure 2: Number of times a variable has been used as input to monitor fatigue load of blade root bending moment in previous researches

forecasts and outperforms methods such as ensemble model output statistics (EMOS). The transformation of the calibrated wind ensemble to wind power requires a suitable power curve model. The application of artificial neural networks (ANN) to train power curves at each turbine at “EnBW Baltic 1” reduces the forecast errors compared to the manufacturers’ power curve. The consideration of all improvements leads to AUV-calibrated ensemble forecasts with reliable forecast uncertainties and up to 18 % improvements in the Continuous Ranked Probability Score (CRPS), as proven in Fig. 3.

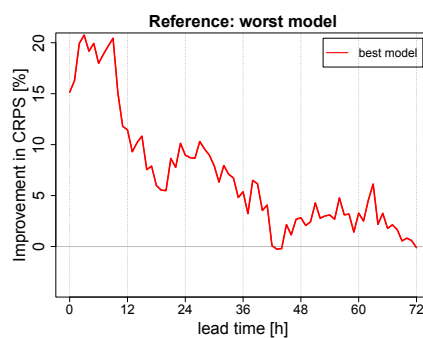

Figure 3: Improvement in the Continuous Ranked Probability Score (CRPS) [%] for wind power forecasts at “EnBW Baltic 1” with lead times up to 0-72 h

The analog ensemble technique is another promising method that can generate probabilistic wind power forecasts. It has the advantage that a power curve model is not required and that the uncertainty information is generated from purely deterministic forecasts rather than existing ensemble forecasts from ensemble prediction systems (Junk et al. [4]).

#### Decision model for operational management

To provide a basis for the assessment of the economic risk of direct marketing, financial and forecasting data has been analyzed to develop various trading strategies. A simulation was implemented that evaluates the costs and revenues of different direct trading approaches in comparison to the fixed feed-in tariff according to the present German renewable energy law (EEG).

It becomes apparent that the varying prices for balancing power have a huge impact on the asset. Thus, improving the quality of the wind power prediction does not automatically lead to an increase of the profit. As long as the current market bonus scheme is in effect, the financial profit at the stock market is almost free of risk and above the level of the fixed feed-in tariff. Without financial aid the crucial parameter is the monthly average price at the stock market. In those cases direct trading

is normally more beneficial than the fixed feed-in tariff. In months with lower average price the balancing power price and the quality of the forecast decides about loss or profit.

#### Summary

The joint research of scientists and a wind farm owner and operator in this project focused on the optimization of operational strategies for large offshore wind farms by enhanced wind power predictions as well as power and load monitoring. The developed methods shall allow a better operation of individual wind turbines and entire wind farms and could be integrated in commercial wind farm management systems.

#### References

- [1] Dörenkämper, M.; Optis, M.; Monahan, A. and Steinfeld, G. (2015): On the Offshore Advection of Boundary-Layer Structures and the Influence on Offshore Wind Conditions, *Boundary-Layer Meteorol.*, DOI: 10.1007/s10546-015-0008-x
- [2] Vera-Tudela, L. and Kühn, M. (2014): On the selection of input variables for a wind turbine load monitoring system. 2nd International Conference on System-Integrated Intelligence: Challenges for Product and Production Engineering. Bremen, 2014.
- [3] Junk, C.; von Bremen, L.; Kühn, M.; Späth, S. and Heinemann, D. (2014): Comparison of post-processing methods for the calibration of 100 m wind ensemble forecasts at off- and onshore sites, *J. Appl. Meteorol. Climatol.*, 53, pp. 950-969.
- [4] Junk, C.; Delle Monache, L.; Alessandrini, S.; Cervone, G.; von Bremen, L. (2015): Predictor-weighting strategies for probabilistic wind power forecasting with an analog ensemble, *Meteorol. Z.*, DOI:10.1127/metz/2015/0659.

# CompactWind: Increase of the Overall Energy Yield per Area at Sites Due to the Utilization of Advanced Single Turbine and Wind Farm Control Strategies

Carl von Ossietzky Universität Oldenburg,  
Institute of Physics, Wind Energy Systems,  
Energy Meteorology

Marc Bromm, Detlev Heinemann,  
Martin Kühn, Andreas Rott,  
Gerald Steinfeld, Lukas Vollmer

## Partners:

Robert Bosch GmbH (coordinator)  
eno energy systems GmbH,  
Technische Universität München –  
Wind Energy Institute

Funding: Federal Ministry for Economic  
Affairs and Energy (BMWi)  
Ref.Nr. 0325492B

Duration: 12/2012 – 05/2016

## Introduction

During the design and the operation of a wind farm it is necessary to consider the mutual aerodynamic interaction of turbines. Wake flow conditions are leading to substantial losses in the energy yield as well as increases in structural loads due to larger inhomogeneity in the inflow. The effects are particularly strong at short dis-

tance behind the wake generating turbines and limit the minimum distances between turbines positioned in a wind farm.

The joint research project CompactWind focuses on the development of turbine and wind farm control concepts for influencing the flow in wind farms to reduce the impact of wake flow conditions. The aim is to maximize the energy yield of a wind farm with respect to its area without a disproportional additional loading of the turbines. This should allow a more efficient and more economic use of the limited number of onshore sites that guarantee high energy yields. The project is carried out in cooperation with the component manufacturer “Robert Bosch GmbH”, the turbine manufacturer and wind farm developer “eno energy systems GmbH” and the “Wind Energy Institute” of the TU München.

## Project Description

### Wind farm control

Concepts for systematically influencing the characteristics of wakes are commonly referred to as active wake control and have recently become an important topic in wind energy research. Proposed methods include

the deflection of the wake behind a turbine caused by active yaw misalignment and individual pitch control. In order to choose the ideal operation strategy for the wind farm in particular ambient conditions, detailed knowledge about the current flow in the farm and its future propagation is required. Within the research project different concepts for mitigating the effects of wake flow will be investigated in simulations, wind tunnel experiments and in a free field campaign for advancing in the development of a sophisticated wind farm controller.

### Investigation of concepts

The downstream development of a wake deficit is dependent on the incoming flow of the atmospheric boundary layer. As a consequence the atmospheric stratification and the related varying vertical wind shear and turbulence intensity cause a large fluctuation in the power yield of wind farms [1]. Considering these parameters in models for wind farm control is therefore necessary to evaluate the impact of control strategies based on flow alteration (Fig. 1) [2].

Within the scope of the joint research project a new simulation code based on an approach combining large-eddy simulations (LES) of the flow with an actuator line

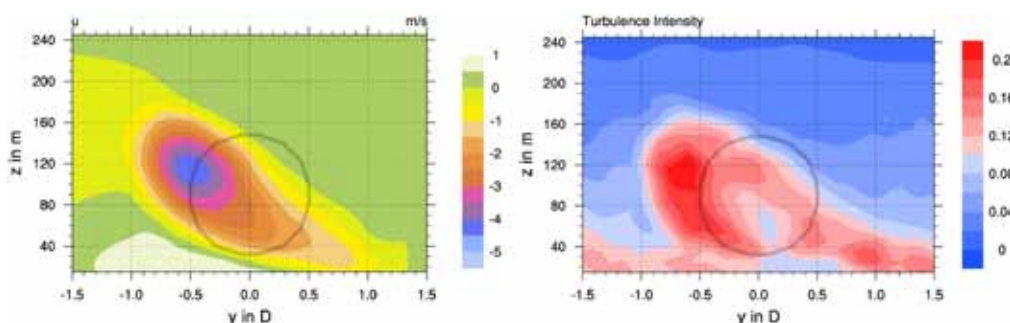

Figure 1: Mean wake deficit and turbulence intensity five rotor diameter behind a yawed wind turbine ( $20^\circ$ ) in a stable stratified boundary layer. Black circle denotes rotor position.

representation of the wind turbines, including their control system and aeroelastic characteristics, has been developed for a comprehensive and realistic overall turbine representation (Fig. 2)[3]. A second computationally less demanding model based on an improved actuator disc representation of the turbine is additionally used if a less detailed turbine response is sufficient. LES wind fields with high spatial and temporal resolution for different atmospheric parameters are used as initial conditions for the simulations.

Both numeric tools allow for a better understanding of the flow development in a wind farm and the wind turbine-flow interaction.

For the validation of the simulation results measurement campaigns in an atmospheric wind tunnel with aeroelastically scaled models of up to 2 m diameter and in the free field on a multi-megawatt wind turbine of eno energy systems will be conducted. The wind tunnel experiments allow to further investigate the aerodynamic interaction of multiple turbines in a wind farm configuration in a controlled environment. Whereas the measurements at the eno turbine in the free field with two nacelle mounted long-range-LiDAR systems and load sensors give the opportunity to verify the transferability of the control concepts under real conditions and to directly observe the impact of the applied strategies on the structural loads of the turbine.

## Summary

Within the joint research project CompactWind the flow in wind farms and how it can be influenced by different turbine control concepts to increase the overall farm energy output and reduce the structural loads on the individual turbines is studied. New control strategies for the integration in commercial wind farm control systems are derived and validated in large-eddy simulations, wind tunnel experiments and in free-field flow and load measurements at multi-megawatt turbines.

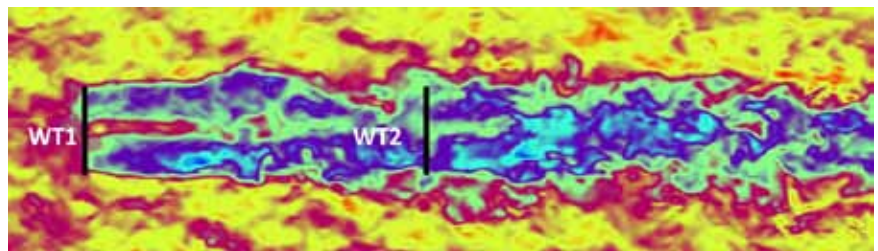

Figure 2: Simulated instantaneous flow field around two turbines in the atmospheric boundary layer at hub height.



Figure 3: Installation of long-range LiDAR measurement system on nacelle of eno 114 wind turbine.

## References

- [1] Dörenkämper, M.; Tambke, J.; Steinfeld, G.; Heinemann, D.; Kühn, M.: 2012 Atmospheric Impacts on Power Curves of Multi-Megawatt Offshore Wind Turbines. Proceedings of the Science of Making Torque from Wind Conference, Oldenburg
- [2] Vollmer, L.; Steinfeld, G.; Heinemann, D.; Kühn, M. (2014): Influence of the Atmospheric boundary Layer on Wind Farm Control, EAWC 10th PhD Seminar on Wind Energy in Europe, Orléans, France
- [3] Bromm, M.; Kühn, M. (2014): Investigating the interaction between wind turbines and atmospheric flow with a coupling of the aeroelastic code FAST and the LES code PALM, EAWC 10th PhD Seminar on Wind Energy in Europe, Orléans, France
- [4] Rott, A.; Kühn, M. (2014): Combining model-based and data-driven optimization of wind farm operation in a learning database, EAWC 10th PhD Seminar on Wind Energy in Europe, Orléans, France

# IRPWIND – Integrated Research Programme on Wind Energy

Carl von Ossietzky Universität Oldenburg  
Institute for Physics, Energy Meteorology  
and Wind Energy Systems

Bruno Schyska, Lueder von Bremen,  
Detlev Heinemann (Energy Meteorology)  
and Wilm Friedrichs, Martin Kühn  
(Wind Energy Systems)

Funding: European Commission  
Ref. No.: 609795

Duration: 03/2014-02/2018

## Introduction

IRPWIND [1] is an integrated research programme that combines strategic research projects and support activities within the field of Wind Energy, with the aim of leveraging the long term European research potential. The concept behind this programme is built on the success of existing initiatives supporting the SET Plan Agenda such as the European Energy Research Alliance Joint Programme on Wind Energy, whose organizational structure and participation is mirrored in this consortium. IRPWIND moves beyond the delivery of research projects and integrates capacities and resources around the development of high risk technologies, allowing Europe to maintain its global competitive leading position in terms of research excellence and implementation of wind power technologies. Several technical and collaborative gaps, currently hampering the next generation of wind energy technologies, have been identified. It is these gaps that IRPWIND now proposes to bridge, with a team that gathers 24 partners and the critical mass of research performers within wind energy across Europe. Besides the research needs identified, the analysis showed a current emphasis on short to

medium term research and demonstration, whereas IRPWIND clearly focuses on the medium to long term research.

Openness of the programme is achieved through the implementation of 2 pilot funding schemes: one promoting mobility of experienced researchers and other accommodating shared use of infrastructures to carry out experiments at multiple facilities all over Europe. IRPWIND will provide a European added value by promoting joint collaborative projects and overall reinforcement of research excellence, in a sector which will be key to Europe's sustainability and economic growth. The ultimate goal of IRPWIND is to accelerate the route to market for breakthrough innovations, and ultimately to contribute to reaching the ambitious European objectives for wind energy generation towards 2050.

## Project Description

At ForWind Oldenburg the research groups Energy Meteorology and Wind Energy Systems are involved in IRPWIND.

The research group Wind Energy System participates in workpackage 63 ("Design of offshore wind farms – Model development") and leads the task on wind turbine control. Furthermore, the research group Wind Energy System contributes to the task on and wind farm array control concepts.

The research group Energy Meteorology participates in workpackage 82 ("Forecasting Tools for Wind Power Plant Operation") and leads three tasks. One task was to conduct an online survey on future data requirements for wind power integration in Europe.

The two other tasks deal with upscaling algorithms of wind power in Europe under the aspect of a minimal set of reference

sites for optimal estimates and the impact of low data quality on the derived estimates.

## Summary

The online survey was distributed amongst stakeholders of the wind energy sector in several European countries. Twenty evaluable answers were collected. The evaluation of the survey is not finalized, yet. However, from the answers provided to the questionnaire three main conclusions can already be drawn:

1. Current data quality is mostly rated 'fair' (Fig. 1)
2. Data use is expected to increase during the next years especially due to grown wind power penetration, technological advances and changed regulations.
3. Data sharing amongst stakeholders needs to be increased (Fig. 2).

The research at new and advanced upscaling algorithms for monitoring European wind power (Fig. 3) can be subdivided into two challenging steps: a) selection scheme of representative reference sites and b) upscaling approach that combines the reference sites in an optimal way.

Firstly, time series of hourly wind energy production for entire Europe on a 7 km x 7 km grid have been simulated for a 35 year period. The aggregated wind power feed-in based on grid-point level is regarded as the "true" feed-in. Statistical downscaling was applied beforehand to MERRA [2] reanalysis data in order to improve the quality of simulated wind power.

Tests for a basic reference site selection scheme based on cluster analyses have been performed and the effect of the number of reference sites on the upscaling estimate was investigated for Europe. The skill

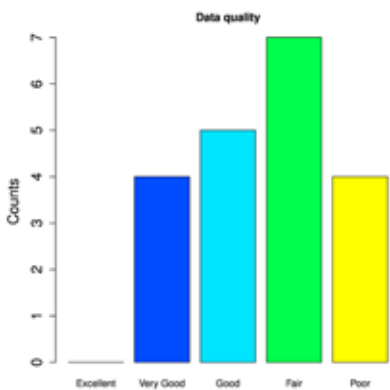

Figure 1: Barplot showing the current data quality as rated by stakeholders.

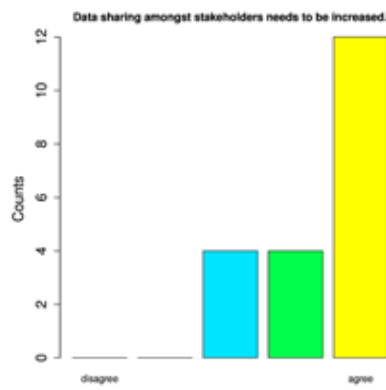

Figure 2: Barplot reflecting the need for increased data sharing amongst stakeholders.

is measured by the correlation coefficient between the simulated feed-in and the up-scaling estimate. The root mean squared error (RMSE) is used, too. As can be seen from fig. 4 approximately 25 reference sites in Europe seem to be appropriate to achieve low RMSEs as well as high correlation.



Figure 3: Selection of reference sites and an appropriate upscaling model is required to monitor European wind power adequately.

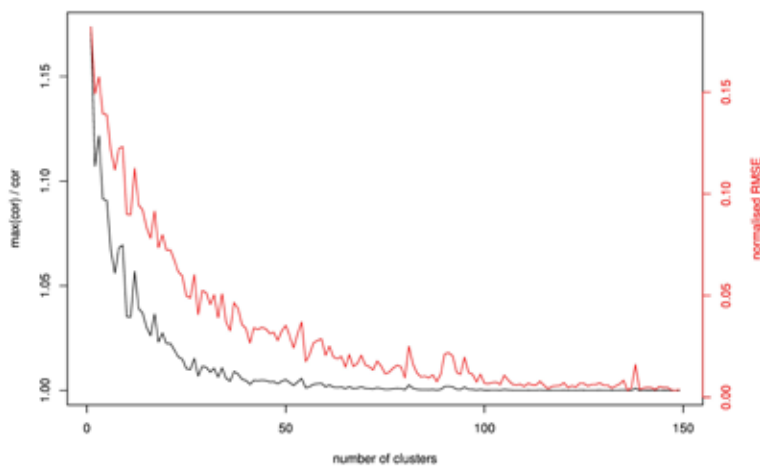

Figure 4: Correlation and RMSE versus the number of reference sites used for the upscaling for a one year testing period.

References

- [1] [www.irpwind.eu](http://www.irpwind.eu)
- [2] Rienecker, M.M., M.J. Suarez, R. Gelaro, R. Todling, J. Bacmeister, E. Liu, M.G. Bosilovich, S.D. Schubert, L. Takacs, G.-K. Kim, S. Bloom, J. Chen, D. Collins, A. Conaty, A. da Silva, et al. (2011), MERRA: NASA's Modern-Era Retrospective Analysis for Research and Applications. *J. Climate*, 24, 3624-3648, doi:10.1175/JCLI-D-11-00015

# IRPWIND – Integrated Research Programme on Wind Energy

Leibniz Universität Hannover (LUH)  
Institute of Structural Analysis,  
Institute of Geotechnical Engineering,  
Institute of Steel Construction,  
Institute for Risk and Reliability,  
Institute of Electric Power Systems

Clemens Hübler, Tim Berthold,  
Tanja Griebmann, Kirill A. Schmoor,  
Karsten Schröder, Matthias Bode

Funding: European Union's Seventh  
Programme for research, technological  
development and demonstration

Ref.Nr. Grant agreement no 609795

Duration: 03/2014 – 02/2018

## Introduction

IRPWIND is a large EU project in the wind energy sector with 24 international partners. Its aim is to foster better integration of European wind energy research activities with the objective of accelerating the transition towards a low-carbon economy and of maintaining and increasing European competitiveness. In this context, IRPWIND includes several non-research aspects (work packages WP 1-5) that are intended to improve the European collaboration. An example is the mobility call for experienced researchers (WP 5) to transfer knowledge. In research, IRPWIND focusses on three main aspects. The first one is the optimization of wind farms through the validation of integrated design models (WP 6). The second one is the reduction of the uncertainty in order to increase efficiency and reliability of future wind turbines (WP 7). The last one is the transformation of the energy supply system (WP 8). LUH is involved in all three research aspects.

## Project Description

IRPWIND with more than ten WP and about 50 tasks covers a broad range of topics in the wind energy sector. That is why only some WP in which LUH was involved can be presented here. Therefore, the focus is on task WP 7.2.2 and 7.4.2. Since IRPWIND started in March 2014, only a first few preliminary results can be shown in addition to a description of the planned work.

In Task 7.2.2, experimental geotechnical tests with model structures in large scale will be designed and performed, to support probabilistic calculations and evaluation of reliability for offshore wind turbine support structures and their foundations (performed under WP7.4). The experimental tests will be in the new "Test Center for Support Structures" in Hannover. The tests are intended for the evaluation of the maximum static bearing capacity of mainly axial loaded piles. With the gained data it will hopefully be possible to get better understanding of the model error of API and CPT based methods. Task 7.2.2 is led by ForWind-Hannover with the contribution of Fraunhofer IWES and AAU. Within 2014, the tests were basically planned and there is a time schedule for them. It is projected to perform the pile tests in October or November 2015. The planned geometries are given in Table 1 and an installation plan is given in Fig. 1.

In Task 7.4.2 probabilistic calculations and the evaluation of reliability for offshore support structures (substructures) will be performed based on geotechnical and grouted connection tests results of WP 7.2. A probabilistic model will be developed for modelling stiffness and strength of soil parameters and for modelling geotechnical load bearing capacity of wind turbine foundations. Comparison of calculated and measured (task 7.2.2) results will be

performed for verification and validation of assumed stochastic variables used in the models. Probabilistic designs based on soil-structure interaction data (task 7.2.2) and deterministic designs will be compared in order to assess the weight saving potential of probabilistic design.

## Summary

Since IRPWIND only started in March 2014, only a few results are already available. Nevertheless, the joint experiments in task 7.2.2 are already planned in detail within a European collaboration (ForWind-Hannover, IWES, and Aalborg University) So, it will be possible to use the same experiments for various subsequent numerical studies in WP 7.4.



	D [mm]	L [m]	Ltot [m]	L/D	t [mm]	D/t	Di [mm]	Weight [t]
<b>Pile 1</b>	273,0	5,7	6,9	20,9	5,0	54,60	263,00	0,23
<b>Pile 2</b>	273,0	6,7	7,9	24,5	5,0	54,60	263,00	0,26
<b>Pile 3</b>	355,6	5,7	6,9	16,0	6,3	56,44	343,00	0,37
<b>Pile 4</b>	355,6	6,7	7,9	18,8	6,3	56,44	343,00	0,43
<b>Pile 5</b>	355,6	5,3	6,5	14,9	6,3	56,44	343,00	0,35
<b>Pile 6</b>	355,6	6,7	7,9	18,8	6,3	56,44	343,00	0,43

Table 1: Planned geometries of the piles

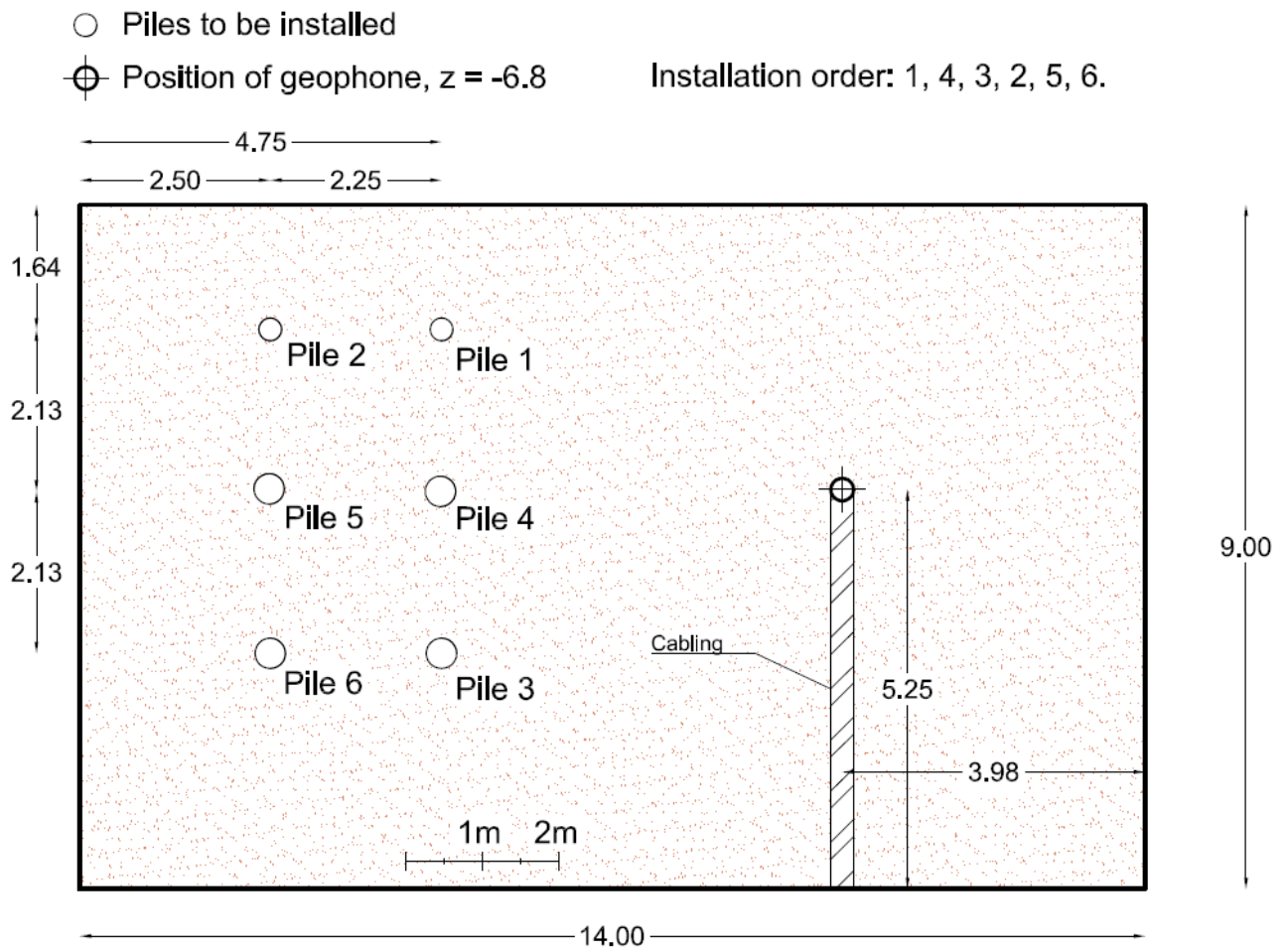

Figure 1: Installation plan of the piles

# INNWIND.EU – Innovative Wind Conversion Systems (10-20MW) for Offshore Applications

Carl von Ossietzky Universität Oldenburg  
Institute of Physics – Energy Meteorology,  
Wind Energy Systems, and  
Turbulence, Wind Energy and Stochastics

Martin Kühn, Bernd Kuhnle,  
Detlev Heinemann, Jens Tambke,  
Joachim Peinke, Michael Hölling,  
Lars Kröger

Funding: European Union's Seventh  
Programme for research, technological  
development and demonstration  
Ref.Nr. 308974

Duration: 11/2012 – 10/2017

## Introduction

INNWIND.EU is the follow-up of the recently finished project "UpWind" addressing the vision of a 10-20MW wind turbine. This project identifies further development and innovation needs on system, subsystem, and component level to achieve the objective of a high performance wind turbine beyond the state-of-the-art. It facilitates the realization of 10-20MW wind turbines by innovations on component level and decreases their time to market for under the premise of cost effectiveness by necessary cost reductions of around 20% for the overall system. The project has a 5 years duration and 27 European partners are involved.

The project is subdivided in six work packages as shown in fig. 1. The work packages can be divided in integrating, embedding and innovative subcomponent based packages. The three subsystem work packages are focusing on the light weight rotor (WP2), innovative, low-weight, direct drive generator (WP3), and standard mass-produced integrated tower and substructure (WP4). WP1 is integrating the innovations in conceptual designs and also focusing on external conditions, wind turbine control and economical assessment. WP 5 and 6 embed the project by being responsible for the management and the dissemination and exploitation.

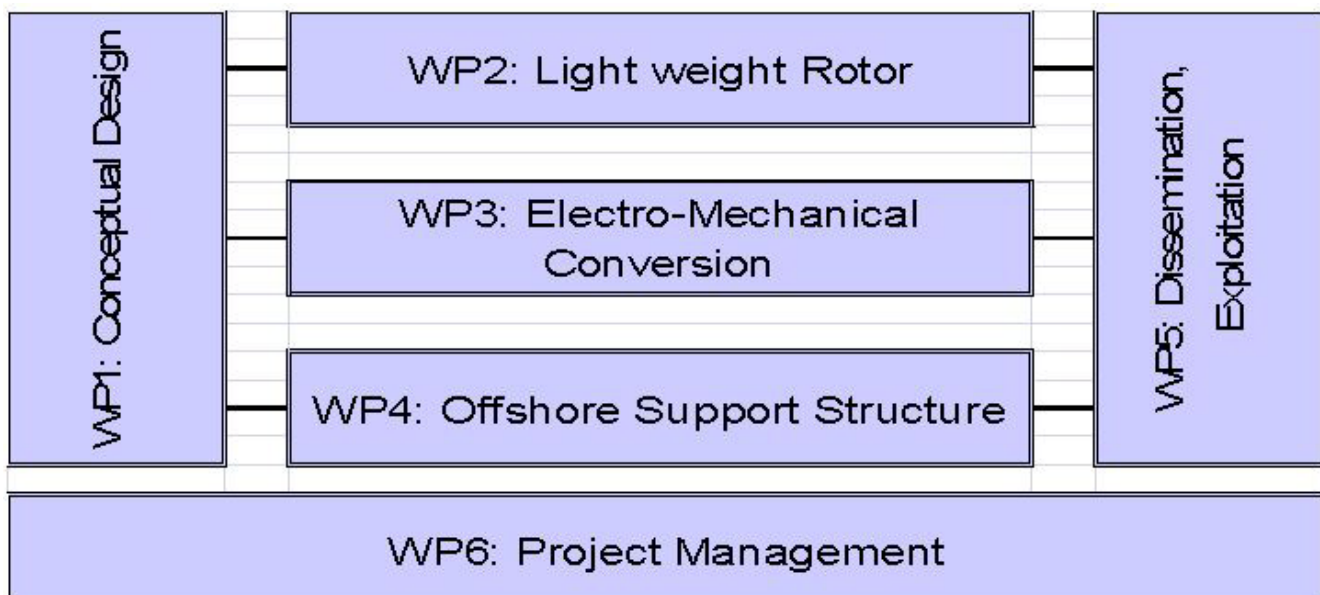

Figure 1: Overview over matrix structure of WPs in INNWIND.EU [1]

ForWind – University of Oldenburg participates in the three Work Packages 1, 2, and 4 and is leading Task 1.1. “External conditions” and Task 4.1. “Innovations on component level for bottom-fixed support structures” and is co-coordinating WP4.

INNWIND.EU is funded by the European Community’s Seventh Framework Programme FP7-ENERGY-2012-1-2STAGE under grant agreement No.308974 (INNWIND.EU).

## Project Description

In WP1, ForWind – University of Oldenburg, namely the Energy Meteorology group, is leading the INNWIND Task 1.1. on modelling the wind conditions up to 300m height. These wind conditions are crucially important for the design of the foreseen 10-20MW offshore turbines with rotor diameters of up to 250 m and maximum tip heights of up to 300 m. Over such a height range, massive changes in wind speed, wind direction and turbulence can occur, which induce high loads in the blades and the whole turbine. In order to model these conditions correctly, it is of utmost importance to simulate the thermal stratification of the marine boundary layer in detail and then to compute the respective heat and momentum fluxes.

In WP2, ForWind – University of Oldenburg, namely the Turbulence, Wind Energy and Stochastics group, is involved in the demonstration and validation of new control concepts by experiments at a medium scale turbine reproducing atmospheric turbulence in a wind tunnel. The task here is to design and built an active grid for the open jet facility [2] of the Delft University of Technology. This wind tunnel has a cross section of 3 times 3 m<sup>2</sup> and will be used for some of the experiments in the work package.

WP4 addresses the challenges for the support structure in the 10-20MW wind turbine class. ForWind – University of Oldenburg, namely the Wind Energy Systems group, is co-leading the Work Package and

is coordinating Task 4.1. The combination of large water depth and tall hub height due to the large rotor, as well as large thrust forces and dynamic loading results in strongly increased demands for the support structure. Furthermore, the increased rotor diameter yields in low rotational speeds and therefore possible excitations of the natural frequency of the relatively stiff support structure by the rotor or blade passing frequency. ForWind – University of Oldenburg is engaged in load mitigation concepts both by sophisticated control of the rotor-nacelle-assembly and optimised with respect to the support structure as well as structural control concepts such as active, semi-active and passive damper devices. ForWind – University of Hanover analyses the feasibility of hybrid jackets comprising classical steel tubes as well as sandwich elements to improve the ultimate limit state strength of bottom-fixed multi member support structures. For this purpose an investigation of sandwich elements on component level is performed in Task 4.1. The conceptual design of a hybrid jacket is made in Task 4.3.

## Summary

The first step in WP1 and especially Task 1.1. was to compile and analyze existing measurements of the offshore wind resources at higher atmospheres. Now the Energy Meteorology group has set up various numerical modeling schemes for the analysis of different weather situations, including extreme events. Especially, the results with the meso-scale model WRF using the MYJ-scheme for the Planetary Boundary Layer (PBL) proved to be the best technique, compared to other models and PBL-schemes. The next step will be the implementation of these results in simpler 2-dimensional and engineering models.

In WP2, atmospheric-like turbulence with defined stochastic properties for the experiments should be generated with the grid. For that, excitation protocols controlling the motion of the grid flaps are generated and the scaling behaviour of turbulence

generated by smaller active grids to larger devices are investigated. First experiments were carried out and improved active grid designs are under development, which will be continued in the next year.

In WP4, the reference support structure was implemented in several aero-elastic simulation codes by the partners. Comparisons of the dynamic behaviour and first simulations regarding the reference design loads were undertaken. The first results proof the issue of resonances in the lower rotor speed band. The requirements for the support structure led to a relatively stiff support structure which resulted in combination with the tower to a first natural frequency around 0.3 Hz which coincides directly with the lower rotational speed limit of 6 rpm. The excitations conduct to highly promoted fatigue loads in the lower rotor speed band. As a first measure, the rotational speed was adjusted to the support structure design window. As a next step load mitigating controls and structural control will be applied to evaluate their influence on the design driving fatigue loads.

## References

- [1] [www.INNWIND.eu](http://www.INNWIND.eu)
- [2] <http://www.lr.tudelft.nl/en/research/blinde-paginas/open-jet-facility/>

# INNWIND.EU – Innovative Wind Conversion Systems (10-20MW) for Offshore Applications

Leibniz Universität Hannover  
Institute of Structural Analysis  
Raimund Rolfes, Jan Häfele

Institute for Building Materials  
Ludger Lohaus, Niklas Scholle

Institute for Steel Construction  
Peter Schaumann, Luka Radulovic

Funding: EC FP 7

Ref.Nr.Grant Agreement No. 308974,  
INNWIND.EU

Duration:11/2012 – 10/2017

## Introduction

The research project with a total of 27 European partners is an ambitious successor for the UpWind project, where the vision of a 20MW wind turbine was put forth with specific technology advances that are required to make it happen. The overall objectives of the INNWIND.EU project are the high performance innovative design of a beyond-state-of-the-art 10-20MW offshore wind turbine and hardware demonstrators of some of the critical components.

## Project Description

The overall objectives of the INNWIND.EU project are the high performance innovative design of a beyond-state-of-the-art 10-20MW offshore wind turbine and hardware demonstrators of some of the critical components. These ambitious primary objectives lead to a set of secondary objectives, which are the specific innovations, new concepts, new technologies and proof of concepts at the sub system and turbine level. The progress beyond the state of the art is envisaged as an integrated wind turbine concept with a light weight rotor having a combination of adaptive characteristics from passive built-in geometrical and structural couplings and active distributed smart sensing and control, an innovative, low-weight, direct drive generator and a standard mass-produced integrated tower and substructure that simplifies and unifies turbine structural dynamic characteristics at different water depths.

The Institute of Structural Analysis is involved in work package 4 (offshore foundations and support structures). Here, the objective is the preliminary design of a hybrid jacket that comprises classical steel and so called sandwich tubes. Sandwich tubes usually have a non-metallic core which might be an elastomer, grout or concrete, enwrapped with steel faces at the inner and outer diameter. Due to the considerably better buckling behaviour of sandwich tubes compared to steel tubes it seems possible to reduce the entire costs for the substructure and hence offshore wind energy in this way. But there are many issues that have to be solved before an application of sandwich tubes for offshore structures is possible.

## Summary

INNWIND.EU will develop conceptual designs for large scale wind turbines between 10MW and 20MW and utilize public results from respective national projects that the partners are involved in to accelerate the progress in designing the 20MW wind turbine. Offshore turbines have technical needs not required for onshore turbines due to more demanding environmental exposure and much higher maintenance costs. This project will deliver significant knowledge for the development of large scale offshore wind farms in deep water terrains, which will pave the way for much higher installed capacity and electricity penetration than seeable with today's technology. The Institute of Structural Analysis will add value to this by the utilization of innovative materials in offshore substructures for turbines beyond state-of-the-art.

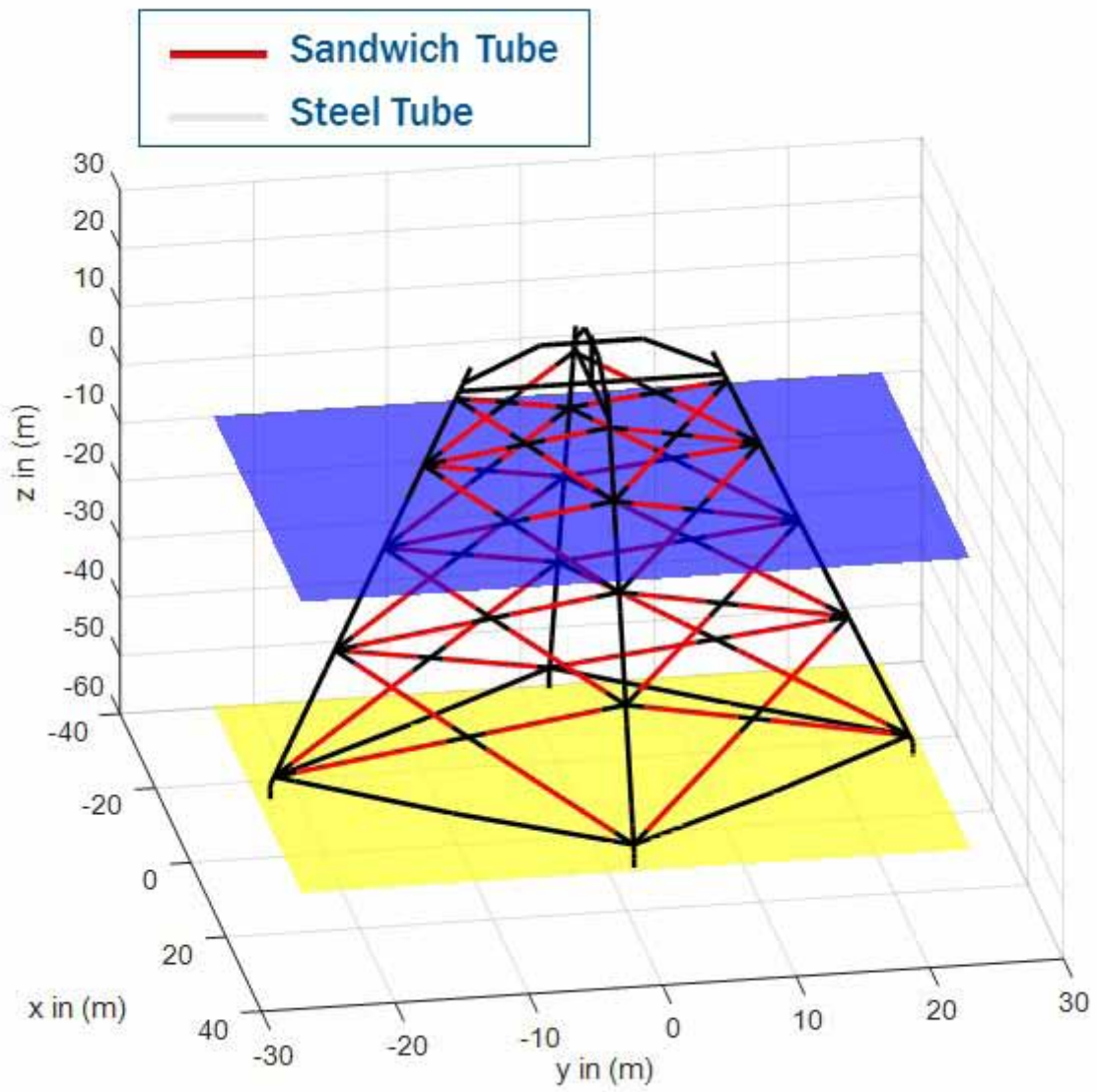

Figure1: INNWIND.EU reference jacket – jacket design with sandwich braces

# INNWIND.EU – Innovative Wind Conversion Systems (10-20MW) for Offshore Applications

Leibniz Universität Hannover  
Institute for Drive Systems and Power  
Electronics (IAL)

Axel Mertens, Dennis Karwatzki

Funding: European Union's Seventh  
Framework Programme for research,  
technological development and  
demonstration  
Ref.Nr. 308974

Duration: 11/2012 – 10/2017

## Introduction

INNWIND.EU is a project with 27 international partners that focuses on innovative and high performance designs of beyond-state-of-the-art 10-20MW offshore wind turbines. The Institute for Drive Systems and Power Electronics (IAL) is involved in project subtasks that address possible power electronic converter concepts, feasible for this power range and the investigated generator concepts. Considered power electronic converters are 3-level NPC con-

verters, Modular Multilevel Converters in back-to-back configuration, modular multilevel direct AC/AC converters and converters with an additional active filter. The two generator concepts are a superconducting generator and a so-called pseudo direct drive with a "magnetic gear" integrated inside the generator.

## Project Description

The power electronic task of INNWIND.EU can be divided into two parts. The first one is a general comparison of converters for high power offshore wind turbines based on new power semiconductors, and new topologies (modular multilevel). Second, power electronics tailored to the superconducting generator and the pseudo direct drive are investigated.

Within the first subtask, the IAL is responsible for the comparison of modular multilevel direct AC/AC converters. Namely, these converters are the Modular Multilevel Matrix Converter (MMMC; [1], [2], [3]; Fig. 1) and the Hexverter ([4], [5], [6]; Fig. 2).

The comparison is based on different performance indicators (e.g. required semiconductor switching power, capacity demand, inductor demand, efficiency), and a cost and size estimation is conducted. An excerpt of the first subtask results for one generator configuration can be seen in Table 1 and Table 2.

Which topology is most advantageous for a scenario depends on the ratio between semiconductor and capacitor costs and the modules offset cost (driver, electronics, etc.) and the cost for mechanical construction. For high power with higher semiconductor and capacitors costs, the MMMC is the preferable topology. In case of lower power, for which mechanical costs and module offset cost have a higher influence, the Hexverter can be advantageous. Under the chosen assumptions for the different cost components, the Modular Multilevel Matrix Converter turned out to be superior for the investigated scenarios. Additionally to the comparison, the Modular Multilevel Matrix Converter and Hexverter design parameters have been verified by a simulation.

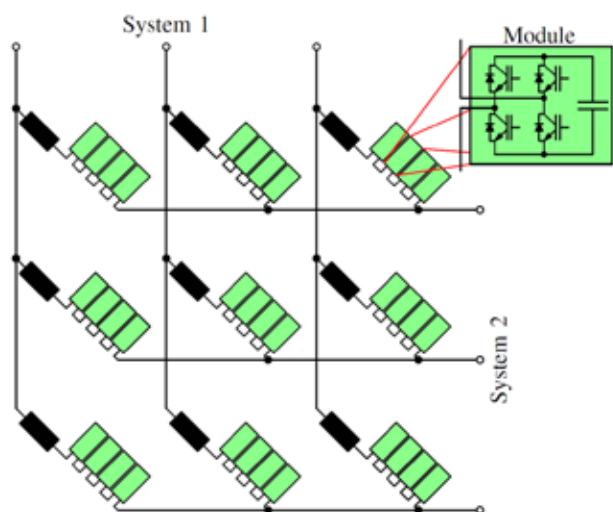

Figure 1: Modular Multilevel Matrix Converter

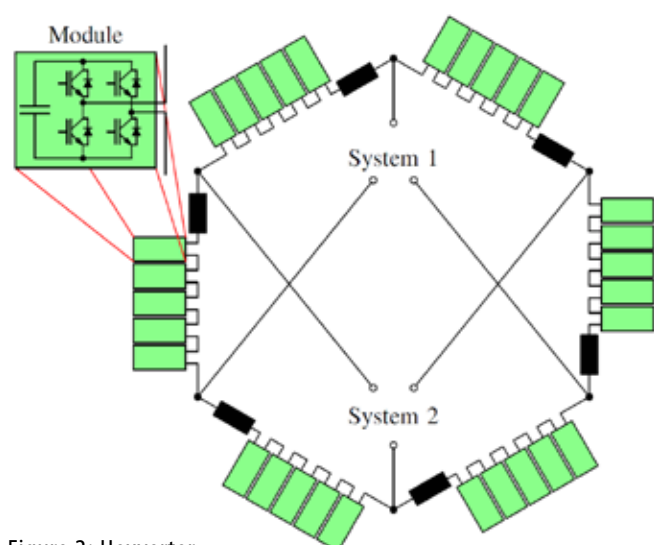

Figure 2: Hexverter

Topology	Number of Modules	Required switching power	Total capacity demand	Maximum stored energy in inductance	Efficiency
Hexverter	48	494 MW	2.8 F	5.6 kJ	97.8%
MMMC	63	328 MW	1.3 F	5.9 kJ	98.3%

Table 1: Performance indicators for a maximum power of 10 MW, nominal generator voltage of 3.3 kV, and nominal generator frequency of 25 Hz; given efficiency at nominal active power without reactive power.

Topology	Number of Modules	Required switching power	Total capacity demand	Maximum stored energy in inductance	Efficiency
Hexverter	48	494 MW	23.2 F	5.6 kJ	97.8%
MMMC	63	497 MW	2.0 F	8.8 kJ	98.4%

Table 2: Performance indicators for a maximum power of 10 MW, nominal generator voltage of 3.3 kV, and nominal generator frequency of 2.5 Hz; given efficiency at nominal active power without reactive power.

Other partners involved in this subtask enhance the comparison by contributing the performance indicators for the Modular Multilevel Converter, 3-level NPC converter, and topologies with an additional active filter.

Future work will concentrate on the second subtask. In this subtask, IAL is responsible for a converter design tailored to the pseudo direct drive. The converter for the superconducting generator will be designed by other project partners.

#### References

- [1] Korn, A.; Winkelkemper, M.; Steimer, P.; Kolar, J.: Direct modular multi-level converter for gearless low-speed drives, in Power Electronics and Applications (EPE 2011), Proceedings of the 2011-14th European Conference on, Aug. 30th 2011-Sept. 1st 2011, pp. 1-7.
- [2] Kawamura, W.; Hagiwara, M.; Akagi, H.: A broad range of frequency control for the modular multilevel cascade converter based on triplestar bridge-cells (mmcc-tsbc), in Energy Conversion Congress and Exposition (ECCE), 2013 IEEE, 2013, pp. 4014-4021.
- [3] Karwatzki, D.; von Hofen, M.; Baruschka, L.; Mertens, A.: Operation of modular multilevel matrix converters with failed branches, Industrial Electronics Society, IECON 2014 - 40th Annual Conference of the IEEE, vol., no., pp.1650,1656, Oct. 29th 2014-Nov. 1st 2014.
- [4] Baruschka, L.; Mertens, A.: A new three-phase ac/ac modular multilevel converter with six branches in hexagonal configuration," Industry Applications, IEEE Transactions on, vol. 49, no. 3, pp. 1400-1410, 2013.
- [5] Karwatzki, D.; Baruschka, L.; von Hofen, M.; Mertens, A.: Branch energy control for the modular multilevel direct converter Hexverter, Energy Conversion Congress and Exposition (ECCE), 2014 IEEE, vol., no., pp.1613,1622, Sept. 14th-18th 2014.
- [6] Baruschka, L.; Karwatzki, D.; von Hofen, M.; Mertens, A.: Low-speed drive operation of the modular multilevel converter Hexverter down to zero frequency, Energy Conversion Congress and Exposition (ECCE), 2014 IEEE, vol., no., pp.5407,5414, Sept. 14th-18th 2014.

# Stochastic Processes

Carl von Ossietzky Universität Oldenburg  
Institute of Physics, Turbulence, Wind  
Energy and Stochastics

Mehrnaz Anvari, Pedro G. Lind,  
Patrick Milan, Tanja Mücke,  
Muhammad Ramzan Luhur,  
M. Reza R. Tabar, Matthias Wächter,  
Joachim Peinke

Funding: Ministry for Science and Culture  
of the Federal State of Lower Saxony  
Ref.Nr. N.A.

Duration: 12/2009 – 11/2014

## Introduction

Wind energy systems have to operate in the turbulent atmospheric boundary layer, which is dominated by highly complex and instationary flows. Consequently, the use of complete and rigorous approaches to the complex dynamics of wind energy conversion is necessarily very much limited. Stochastic methods and stochastic modelling offer an efficient alternative approach. Few crucial variables are separated from

the larger number of less important ones, which are represented by simplified noise terms. This leads to compact models which are computationally highly efficient, nevertheless covering the essential dynamics. Moreover, noisy components are neither neglected nor averaged out, but their contribution to the dynamics can be precisely analysed by advanced methods. Especially in atmospheric flows the level of complexity is generally very high. The application of stochastic methods has already led to practical approaches in several cases.

## Project Description

### Turbulent character of wind energy

The effect of the turbulent atmospheric wind on the statistics of the electric power output of wind energy systems has been systematically investigated. Typical properties of turbulence have been found to be fed into the electrical grid, such as pronounced heavy-tailed statistics of extreme fluctuations and complex correlations on spatial scales up to hundreds of kilometers. A publication in a high-level physics journal [1] has found significant resonance [2].

### Stochastic rotor model for wind turbine simulations

A stochastic approach to model the dynamics of aerodynamic forces on wind turbine blade elements in unsteady inflow has been developed during the recent years [3]. In 2013, this model was integrated into the aerodynamic simulation software package FAST/AeroDyn as an alternative to the static table lookup approach in the classical blade element momentum (BEM) concept. The comparison of force time series obtained through classical and stochastic AeroDyn shows that the latter generates additional dynamic force fluctuations, see fig. 1. The classical AeroDyn only follows the mean of the local fluctuations and neglects information on the force dynamics. Furthermore, the statistical comparison in terms of increment probability density functions (PDF) gives consistent results.

### Langevin Power Curves and monitoring of wind turbines

The well-known concept of the Langevin Power Curve (LPC) [4][5] is able to determine the energy conversion dynamics of wind turbines directly from measurements of wind and electrical power output, inde-

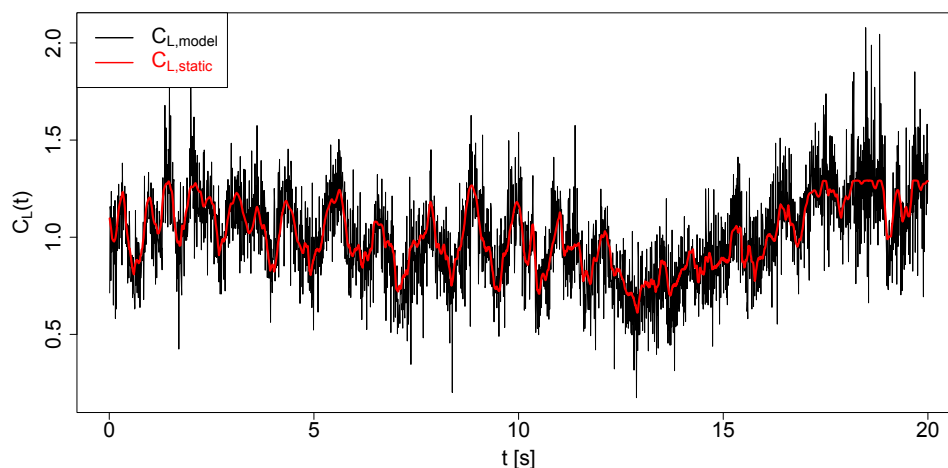

Figure 1: Excerpt of time series of static and modelled lift coefficient  $C_L$  for a blade element. Red color represents the static results obtained by the original AeroDyn code, and black the coefficients obtained from the stochastic model.



pendent of the site conditions. A detailed study of convergence, parameter dependence, and data requirements of the Langevin power curve concept had been conducted already in 2012. In 2013, this study could be completed and a publication was submitted [6].

### Langevin Power Curves for Wind Farms

The LPC method has been extended to characterize and model the power performance of wind farms. As an additional variable the wind direction is considered. The resulting power characteristics turn out to be especially precise and well-behaving, compared to single WEC. Furthermore, in the case of a wind farm, a new parameterization of both drift and diffusion functions allows for a much simplified description. The practical application of the method will significantly benefit from these findings [7]. An example of the drift field, LPC, and IEC power curve of a wind farm is given in fig. 2.

### Dynamics and intermittency of load fluctuations in wind energy converters

As a contribution to the research project OWEA Loads (see there), load measurements in offshore wind energy converters (WEC) are investigated. Available methods are extended to the analysis of multivariate data of a single WEC. In 2013 measure-

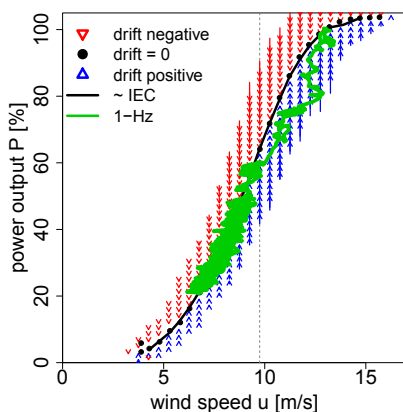

Figure 2: Excerpt of time series of static and modelled lift coefficient  $C_l$  for a blade element. Red color represents the static results obtained by the original AeroDyn code, and black the coefficients obtained from the stochastic model.

ment data have been prepared and their statistical properties analyzed. As next step, a stochastic evolution equation of the torque shall be derived. A further challenge will be the design of a load model which uses multivariate operational data of the WEC instead of a wind speed measurement.

### Interaction and dynamics of turbines in a wind farm

Special attention has been given to the mutual influence and interactions between single turbines in a wind farm. Different methods from the fields of stochastic methods and nonlinear dynamics have been explored to gain more insight in these processes. By deriving a synchronization measure for different turbines it could be shown that synchronized states tend to be connected to extreme fluctuations in electrical power output (compare SEE). The electrical interaction between turbines in electrical networks was studied using an extended Kuramoto equation to model the behavior of coupled oscillators.

### Stochastic method for in-situ damage analysis

The concept of the LPC was extended for early and reliable detection of damage to mechanical structures [8]. It could be shown that changes in mechanical properties are sensitively detected even in changing working conditions, as they are especially typical for WEC. This work was selected for special reports [9].

### Summary

Stochastic methods have been further developed to follow the evolution of challenges in wind energy research and industrial applications. Especially problems and applications concerning interactions within and energy conversion dynamics of wind farms are experiencing growing relevance and attention. Besides incorporating improvements from the literature, extensions of existing stochastic methods have been conducted for improved estimation and analysis of noise terms as well as for multi-dimensional systems.

### References

- [1] Milan, P.; Wächter, M.; Peinke, J.: Turbulent Character of Wind Energy, *Physical Review Letters* 110, 138701 (2013)
- [2] Zyga, L: Wind turbines operate under great turbulence, with consequences for grid stability, *Phys.org* online article, <http://phys.org/news/2013-04-turbines-great-turbulence-consequences-grid.html> (2013)
- [3] Luhur, M. R.; Peinke, J.; Schneemann, J.; Wächter, M.: Stochastic modeling of lift and drag dynamics under turbulent wind inflow conditions, *Wind Energy*, published online, DOI: 10.1002/we.1699 (2014)
- [4] Anahua, E.; Barth, S.; Peinke, J.: Markovian power curves for wind turbines, *Wind Energy* 11, 219-232 (2008)
- [5] Gottschall, J.; Peinke, J.: How to improve the estimation of power curves for wind turbines, *Environmental Research Letters* 3, 015005 (7pp) (2008)
- [6] Mücke, T.; Wächter, M.; Milan, P.; Peinke, J.: Langevin power curves from numerical modelling and monitoring of wind energy converters, submitted to *Wind Energy*
- [7] Milan, P.; Wächter, M.; Peinke, J.: Stochastic modeling and performance monitoring of wind farm power production, *Journal of Renewable and Sustainable Energy* 6, 033119; doi: 10.1063/1.4880235 (2014)
- [8] Rinn, P.; Heißelmann, H.; Wächter, M.; Peinke, J.: Stochastic method for in-situ damage analysis, *The European Physical Journal B* 86, 1-5 (2013)
- [9] Selected as highlights in *Europhysics News* [http://www.europhysics-news.org/index.php?option=com\\_content&id=424](http://www.europhysics-news.org/index.php?option=com_content&id=424)  
Selected for *pro-physik*: [http://www.pro-physik.de/details/news/5352881/Wenn\\_der\\_Mast\\_zu\\_kraeftig\\_wackelt.html](http://www.pro-physik.de/details/news/5352881/Wenn_der_Mast_zu_kraeftig_wackelt.html)

# preInO

Universität Bremen  
 Bremen Institute of Industrial Technology  
 and Applied Work Science (BIBA)

Marco Lewandowski, Stephan Oelker

Funding: Federal Ministry for Economic  
 Affairs and Energy (BMWi)

Ref.Nr. A325587A

Duration: 04/2013 – 03/2016

## Introduction

The growing number of plants at sea, a varied demand for electricity and possible downtimes require an optimization of the maintenance of offshore wind turbine generators (WTG) in the future. Especially unplanned downtimes lead to additional maintenance effort and thus to higher maintenance costs.

## Project Description

In the project “preInO“ tools and methods for the realization of the pro-active maintenance are being developed by means of artificial intelligence and automatic self-organization. These are then validated by means of a demonstrator. Great optimization potentials concerning the deployment of personnel, spare parts and transport are hoped for. The project will be implemented in cooperation with a turbine manufacturer and a software developer.

The objective of the project is to research comprehensive methods and tools taking several data sources into account that can be used for a proactive maintenance strategy of the service of WTG. To enable an accurate prognosis about the condition of a component, a variety of data sources such as sensor values, statistic data, maintenance data from the maintenance history file, externalized staff know-how, weather data as well as stock inventory and personnel planning are analyzed and automatically

linked to a relevant event. The prioritization of the detected errors, the dynamical planning of the scope of maintenance and the scheduling into the work flow with corresponding logistics using decentralized controlling systems are based on the points of the project that are to be researched. These points of research should enable a proactive maintenance strategy for WTG.

## Summary

Offshore maintenance processes are recorded and data sources for an automated decision support are identified. Based on this, a basic concept will be developed and the required methods analyzed or researched. This will enable an automated prioritization of detected errors. The acquired knowledge will flow into the development of a software module. The developed methods and data are validated with real data as far as possible using a demonstrator which is in the course of development.

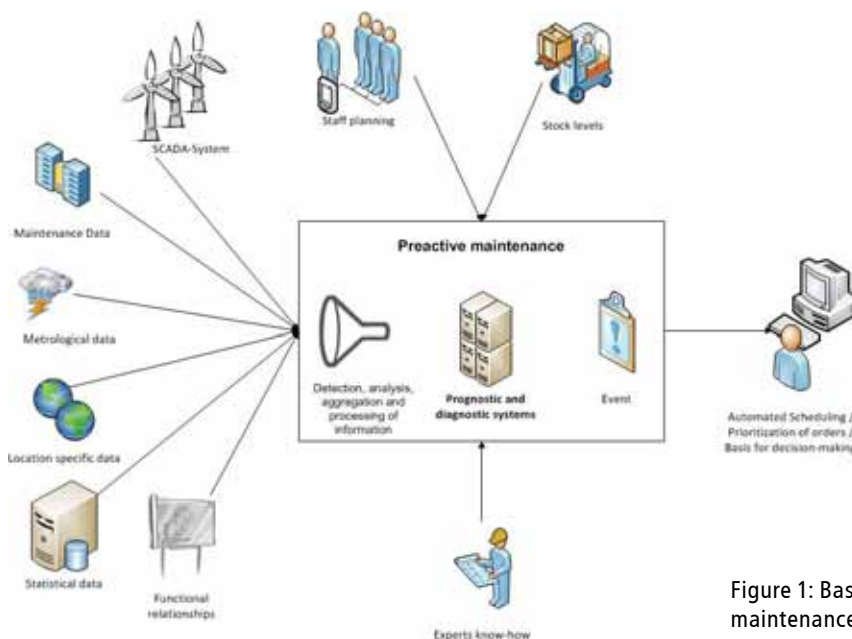

Figure 1: Basic concept for a pro-active maintenance strategy

# SAMS Save Automation of Maritime Systems

Carl von Ossietzky Universität Oldenburg,  
Computing Science, Business Engineering

Axel Hahn

Funding: Federal State of Lower Saxony

Duration: 10/2014 – 08/2018

## Introduction

Shipping is always a joint undertaking of humans and their technology. The increasing usage of the oceans for transportation, fishing, exploration and even recreation increase threats for humans, the environment and even the economy in case of disrupted supply chains. Consequently, the challenge faced by marine engineers and the scientific community is designing save and environment friendly maritime systems.

## Project Description

In order to facilitate research in the domain of integrated and save maritime supervision, control and assistance technology, the PhD program "Save Automation of Maritime Systems (SAMS)" was approved and initiated. SAMS is a joint PhD program of the University of Oldenburg, the Jade University of Applied Science and the research institute OFFIS. It is funded by the federal state of Lower Saxony.

SAMS offers 15 three year scholarships in a period between 2014 until 2019.

## Summary

Joint Phd Program for safety of maritime Systems.



# Critical Systems Engineering for Socio-Technical Systems

Carl von Ossietzky Universität Oldenburg  
Research Center Safety Critical Systems /  
Computing Science, Business Engineering

Axel Hahn

Funding: Federal State of Lower Saxony

Duration: 03/2013 – 03/2016

## Introduction

Critical Systems, i.e., systems whose failure either endanger human life or cause drastic economic losses, form the technological backbone of today's society and are an integral part in such vastly diverse industrial sectors as automotive, aerospace, maritime, automation, energy, health care, banking, and others.

## Project Description

The Interdisciplinary Research Center on Critical Systems Engineering for Socio-technical Systems focus on instances of such socio-technical systems in the transportation domain, where the overarching objectives are to achieve safe and green mobility, through cooperative semi-autonomous guidance of vehicles with humans in the loop, such as in their roles as drivers, operators, navigation officers, flight controllers, etc., and consider two industrial sectors key in Lower Saxony, the automotive and maritime domains. Such systems are safety critical – human errors, technical failures and malicious manipulation of information can cause catastrophic events leading to loss of life. Creating sufficiently precise real-time mental or digital images of real-world situations, and assuring their coherence among all involved actors (both humans and technical systems) as a basis

for coordinated action is a major challenge in socio-technical system design. This calls for constructive approaches involving intuitive and scalable patterns of cooperation, between humans and technical systems, seeking for a balanced sharing of tasks best matching both the abilities of humans and technical systems, or between technical systems. It calls for insights in understanding humans in their interaction with technical systems. It calls for layered approaches in aggregating information along both spatio-temporal and cognitive dimensions. It calls for robust and adaptable designs, seamlessly catering with adverse and changing environmental conditions. It calls for executable and composable models of socio-technical systems, both human and technical, allowing to adaptively, as it were, "zoom" into detailed levels when reaching critical states to provide fine-grained views of the actual interactions, as well as the need to aggregate to coarse views in order to cope with the sheer complexity of such models.

Integrating highly visible research at the Carl von Ossietzky University of Oldenburg in safety critical systems, neurosensory systems, and maritime systems, and foreseen research in its newly founded European Medical School, the center for critical systems engineering of socio-technical systems will create a university-wide long-term shared research strategy and build an interdisciplinary research team covering systems engineering, cognitive psychology, human-machine interaction, dependable system design, security engineering, embedded systems, networked and distributed control, distributed sensors systems, and health-state monitoring. With its partners OFFIS, DLR, and SafeTRANS it integrates deep application know-how, strong industrial networking guaranteeing high industrial impact, and a unique demonstration platform for future mobility solutions, AIM. Through its Think Tank, the

Interdisciplinary Research Center on CSE will set up this shared research strategy. Through its projects, it will identify possible solutions and pave the way for a leading position in acquiring large-scale projects targeting identified innovation gaps. Through its living labs it will demonstrate the high potential of its scientific achievements. Through its college it will foster scientists capable of acting as mediators and catalysers for innovation in this highly interdisciplinary field. With the boost in visibility stemming from the establishment of the Interdisciplinary Center for Critical Systems Engineering for Socio-technical Systems, the site Oldenburg will achieve a poleposition in winning strategic proposals both on the national and European level within its scope.

## Summary

The Interdisciplinary Research Center on Critical Systems Engineering for Socio-technical Systems addresses critical systems, which rely on synergistically blending human skills with IT-enabled capabilities of technical systems to jointly achieve the overarching objectives of the system-of-systems.



# PhD Program on "System Integration of Renewable Energies"

Carl von Ossietzky Universität Oldenburg  
Institute of Physics, Research groups:  
Energy Meteorology; Wind Energy  
Systems; Turbulence, Wind Energy and  
Stochastics

Funding: Ministry for Sciences and  
Culture of the Federal State of  
Lower Saxony, presidential chair of  
the University of Oldenburg and EWE  
research center NEXT ENERGY

Duration: 07/2012 – 12/2016

## Introduction

The joint PhD program "System Integration of Renewable Energy" of the University of Oldenburg and the Jade University focuses on the save and economic grid integration of renewable energy sources. The research of the 20 (+5 associated) PhD students is dedicated to wind and solar power forecast models, the management and control of smart grid, storage, and renewable energy and hybrid systems for geographic and economic planning system of future renewable energy networks. Five PhD projects are carried out at ForWind, Oldenburg.

## Project Description

### Wind Farm Control (WFC) using a Flow Interaction Model

PhD Student: Mehdi Vali

Supervisor: Prof. Dr.-Ing. Martin Kühn

The goal of this PhD project is to develop an advanced control concept for wind farms. In comparison of the individual wind turbines, wind farm control (WFC) is much more challenging due to the aerodynamic interactions among turbines. These interactions come from the fact that downwind turbines are in the wake of upwind ones. Today commercial turbines are regulated

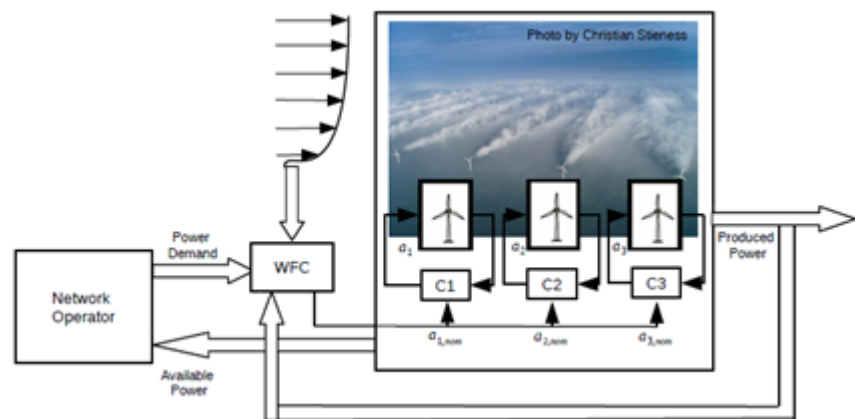

Figure 1: Schematic demonstration of distributed architecture of wind farm control.

independently regardless of their interactions i.e. greedy control. The amount of turbine interactions on one hand depends on time-varying atmospheric conditions e.g. inflow direction, speed and turbulence, and atmospheric stability. On the other hand, individual turbine control settings can influence the wake-induced velocity deficit and flow direction. Thus, this PhD project aims to elaborate the exploration in WFC to minimize wake-induced loads and energy losses. Compared with model-free WFC approaches the importance of the aerodynamic models for WFC is explored in this research.

Fig. 1 illustrates the used state-of-the-art control architecture based on the wind turbine axial induction factor (AIF). The engineering Jensen model is utilized to estimate the wake induced velocity deficit at each downstream turbine. The high-level AIF-based WFC is developed using the game theoretic (GT) approach to distribute power references which lead to the global power maximization. The individual WTCs are adjusted to influence their AIF using torque and pitch controllers. The effectiveness of the developed control scheme in power

maximization is evaluated through some simulation studies.

## Summary

The 5 PhD projects deal with different aspects how The 5 PhD projects represents a model chain with respect to temporal and spatial scales from short-term power forecasting using Numerical Weather Prediction, mesoscale wind fluctuations, interaction of turbines in a wind farm and finally the control of single turbines to ease grid integration and to reduce maintenance costs. Consequently, the participation in the PhD Programme ideally supports the ForWind's vision to increase the economic and technical efficiency of wind farms.

## References

Vali, M.; Kühn, M.: Distributed control of wind farms using a flow interaction model and a multi-agent approach, 10th PhD Seminar on Wind Energy in Europe, France, October 2014.



# Smart Nord

Carl von Ossietzky Universität Oldenburg  
Turbulence, Wind Energy and Stochastics,  
Energy Meteorology

Gerald Lohmann, M. Reza Rahimi Tabar

Funding: Ministry of Science and Culture  
of the federal state of Lower Saxony  
Ref.Nr. ZN 2764/ZN 2896

Duration: 03/2012 – 02/2015

## Introduction

The project Smart Nord (Intelligent Networks at North Germany) is funded by the Lower Saxony Ministry for Science and Culture and is an interdisciplinary research project in the context of renewable energies. By the substitution of nuclear energy by renewable sources we will - with increasing share of such sources – have to face a fundamental change in the structure and control systems of power grids. This requires research concerning reliability and climate-friendly as well as affordable design of renewable energy supplies.

Among the renewable energy sources the use of wind power and photovoltaic has a priority in the future and they should become a reliable substitute for conventional large-scale power plants. The aim of the interdisciplinary research in Smart Nord is the development of coordination systems for efficient embedding of intermittent renewable sources and control strategies for the contributions of decentralized power resources.

## Project Description

The interdisciplinary research project Smart Nord is working on the development of new features for efficient embedding of decentralized renewable sources and ensuring power grid stability under influence of such sources. More than 40 scientists are working in this project, which is divided into six subprojects TP1 to TP6. ForWind is working on subproject TP5 and aims to i) characterize the short term, strongly intermittent solar and wind power inputs using available high frequency time series, ii) non-parametric estimation of stochastic dynamical equations for the solar and wind powers with strong jumps and iii) study the effect of short term extreme fluctuations of solar and wind powers on the grid dynamics as, e.g., the voltage stability.

## Results

For the first part of project we characterized the stochastic properties of the wind and solar energy sources by studying their spectrum and multifractal exponents. The computed power spectrum from high frequency time series of solar irradiance and wind power reveals a power-law behaviour with an exponent  $\sim 5/3$  (Kolmogorov exponent) for frequencies of  $0.001 \text{ Hz} < f < 0.05 \text{ Hz}$ , which means that the power grid is being fed by turbulent-like sources. These results are derived from data measured on operating wind turbines and continuous solar irradiance measurements with sampling rate 1 Hz, in Germany and in the United States. The wind farm studied has 12 wind turbines spread over an area of roughly  $4 \text{ km}^2$ . The United States National Renewable Energy Laboratory (NREL) performed a one-year measurement campaign at Kalaheo Airport, Hawaii, USA, from March 2010 until March 2011 using 19 LI-COR LI-200 pyranometers to measure effective solar radiation on horizontal

and inclined surfaces with a 1Hz temporal resolution. From this publicly available data, the subset of effective horizontal solar radiation was selected, processed and checked to yield about  $\sim 10^7$  synchronised values of 1Hz temporal resolution measured by the aforementioned 17 pyranometers on 378 days.

We note that linear techniques, such as spectral and correlation analysis, can uncover only linear structures of given time series. However, due to the nonlinear relation of wind velocity and its power (i.e.  $P(t) \sim u^3(t)$ ), the power output for a single wind turbine is more intermittent than the wind velocity itself. We studied also the non-linear properties and intermittent behaviour of these time series by deriving their multi-fractal exponents. For such time series, intermittent behaviour can be quantified through increments statistics in some time lag  $\tau$ , i.e.  $\Delta x_{\tau} = x(t+\tau) - x(t)$ , where  $x(t)$  is the wind power, solar irradiance or clear sky index time series. Extreme values of increments can be seen as gusts and strong jumps in the increments of wind power and solar irradiance, respectively.

Let us denote  $S(n, \tau)$  the order  $n$  absolute moment of  $x(t)$  and it behaves as  $S(n, \tau) = \langle |\Delta x_{\tau}|^n \rangle \sim \tau^{\xi_n}$ . We say that the process is scale invariant, if the scale behavior of the absolute moment  $S(n, \tau)$  (known as structure function) has a power law behaviour in a certain range of  $\tau$ . The process is called monofractal if  $\xi_n$  is a linear function of  $n$  and multifractal if  $\xi_n$  is nonlinear with respect to  $n$ .

An estimation of exponents  $\xi_n$  for given time series can be questioned if the time series do not, as is often the case, exhibit power-law behaviour over a broad interval. In such cases, instead of rejecting outright the existence of scale invariance, one can first explore the possibility of scale invari-



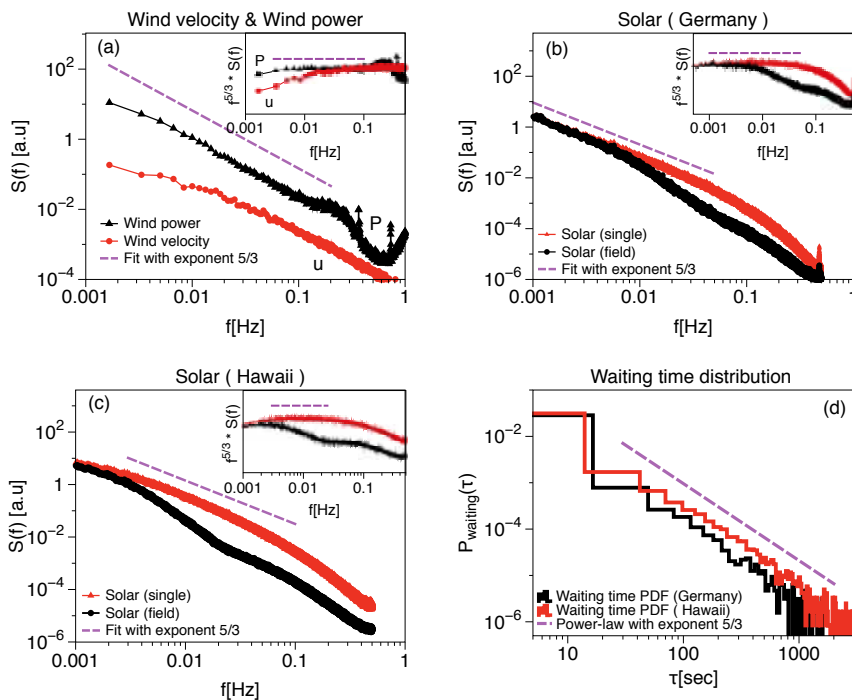

Figure 1: Power spectra of wind velocity, wind power and irradiance fluctuations in log-log scale. The Kolmogorov exponents  $-5/3$  are represented by dashed lines. (a) Power spectrum of wind velocity and wind power. (b, c) Spectrum of solar irradiance measured in Germany and Hawaii. In the insets of (a) and (b), log-log plots of the compensated energy spectra  $f^{5/3} S(f)$  versus frequency  $f$  are shown. The turbulence type  $-5/3$ -law presented in irradiance fluctuations is seen for single sensor, for frequencies  $0.001 < f < 0.05$  Hz. (c) Power spectra of irradiance fluctuations for single (red) and averaged over 17 sensors (black) in log-log scale measured in Hawaii. (d) Waiting time distribution functions of cloudy sky state. For time scales  $10 \text{ s} < \tau < 2000 \text{ s}$ , it shows a power law behaviour with exponent  $\sim -5/3$ .

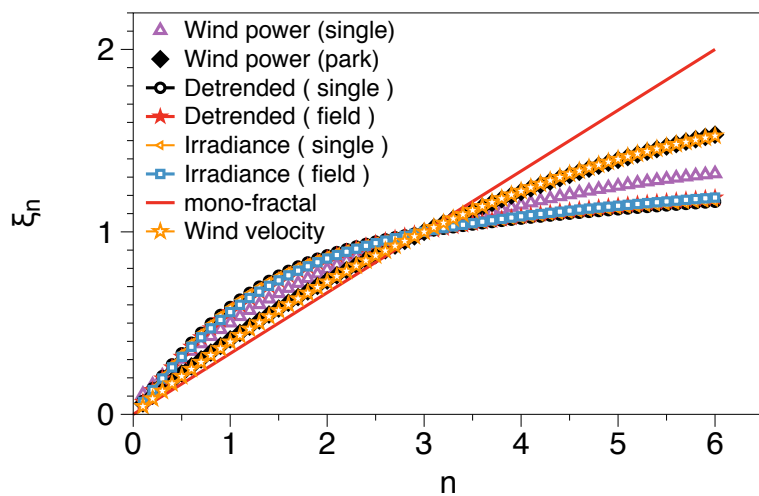

Figure 2: Multi-fractal exponents of solar irradiance, clear sky index (detrended), wind power and wind velocity fluctuations. Multi-fractality has been checked by the scaling behaviour of the moments  $S(n, \tau)$  relative to the third moment, i.e. extended self-similarity ESS [1]. We observed that all of the moments (up to  $n=6$ ) of solar irradiance and wind power time series behave as  $S(3)^{\xi_{n-3}}$  within the scaling region 10-1000 s, see text.

ance via the concept of extended self-similarity (ESS) [1].

The estimated scaling exponents  $\xi_n$  from ESS are displayed in Fig. 2, for single wind power, wind farm, single irradiance measurements, irradiance of field, clear sky index (detrended) and finally for the measured wind velocity. In this respect, the solar data (irradiance and clear sky index) are strongly intermittent, and in turn, the wind power (single) and wind power (field) are less intermittent.

As a first result, it is important to recognise here the intermittent nature of such energy sources in order to properly adapt their integration in power grids. This is especially useful as large synchronous generators are progressively replaced by such volatile power plants. In particular, the nature and amplitude of possible fluctuations must be known to design and dimension appropriate solutions such as storage or, even better, new optimised control systems to suppress the extreme fluctuations.

#### References

- [1] Tabar, M.; Reza Rahimi, et al.: Kolmogorov spectrum of renewable wind and solar power fluctuations, *European Physical Journal* (2014), in press.
- [2] Lohmann, G. et al.: Flickering Events in Wind and Solar Power, *Proceedings of the 28th International Conference on Informatics for Environmental Protection*, Oldenburg, Germany (2014).

# Smart Nord

Leibniz Universität Hannover  
 Institute for Drive Systems and Power  
 Electronics (IAL)

Axel Mertens, Felix Fuchs, René Dietz

Funding: Ministry of Science and Culture  
 of Lower Saxony (MWK)

Duration: 03/2012 – 02/2015

## Introduction

In the IAL subproject of Smart Nord, the influence of grid resonances on the control behavior of grid-connected of wind turbines is analyzed. In addition, the general behavior and interaction of grid connected converters are analyzed.

## Project Description

As a member of the research association “Smart Nord – Intelligent Grids Northern Germany” funded by the Ministry of Science and Culture of Lower Saxony, Germany, the IAL deals with the question how to optimize converter control in renewable power systems with respect to their overall dynamics. In this context, research especially focuses on the definition of the operational limits.

Another focus of the project is resonances within the grid and how they can deteriorate the control behavior of grid-connected converters. An equivalent circuit of the system is given in Fig. 1.

Resonances are the result of capacitive elements in the network. An analysis considering capacitive cable elements is performed. It is demonstrated that the resonance evoked by the cable can bring the wind turbine current control to oscillatory behavior. For validation, a three-phase simulation model is set up, Fig. 2. The simulation results validate the predicted dynamic behavior which can be seen in Fig. 3.

In the next steps of this project topic, an analysis of general grid resonances and their interaction with the converter control are performed [2]. The interdisciplinary aspects of the project are demonstrated in [3].

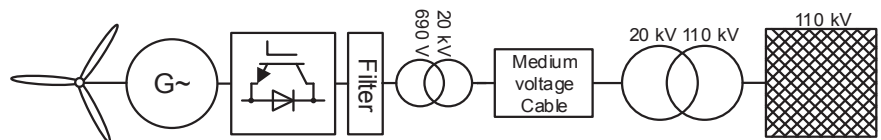

Figure 1: Single-phase equivalent circuit of analyzed grid connected wind turbine

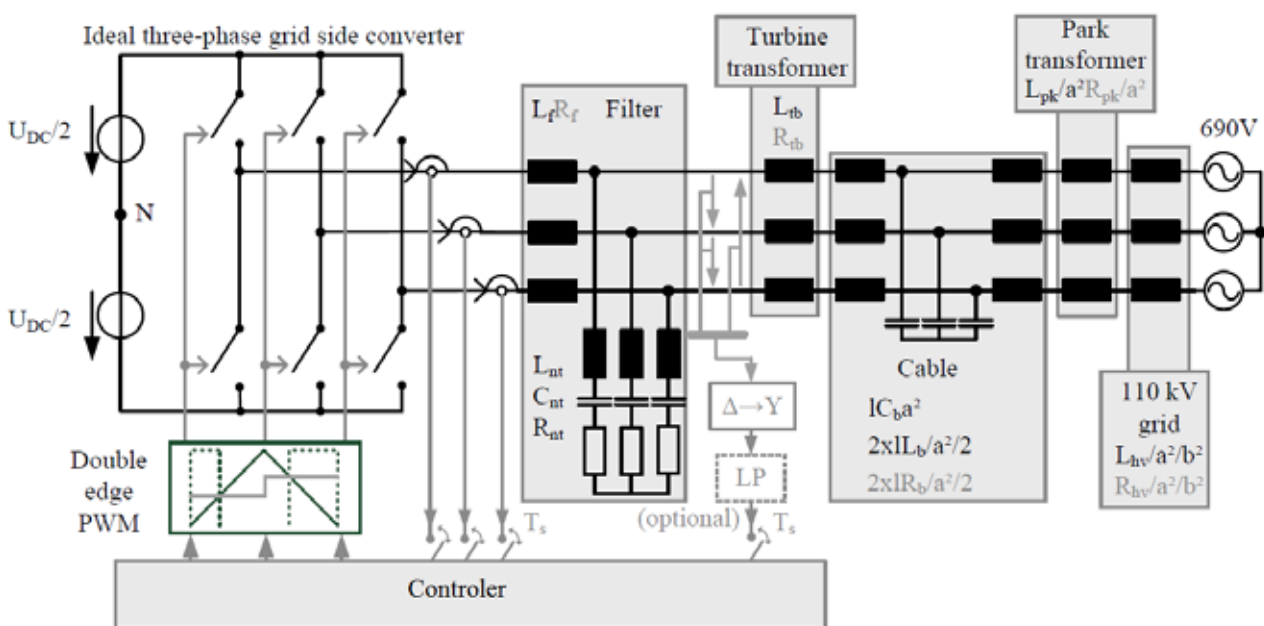

Figure 2: Grid-connected converter model including cable capacitances [1]

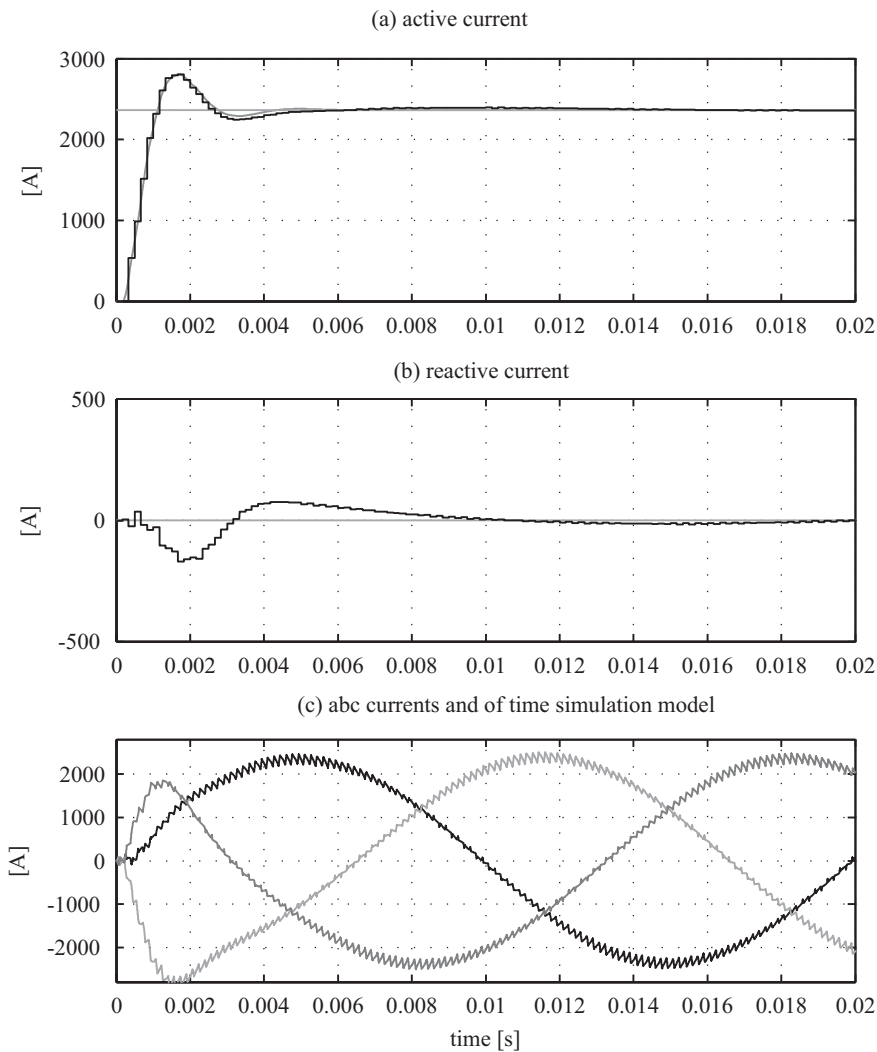

Figure 3 a: Three phase simulation results and theoretical predicted step response [1]

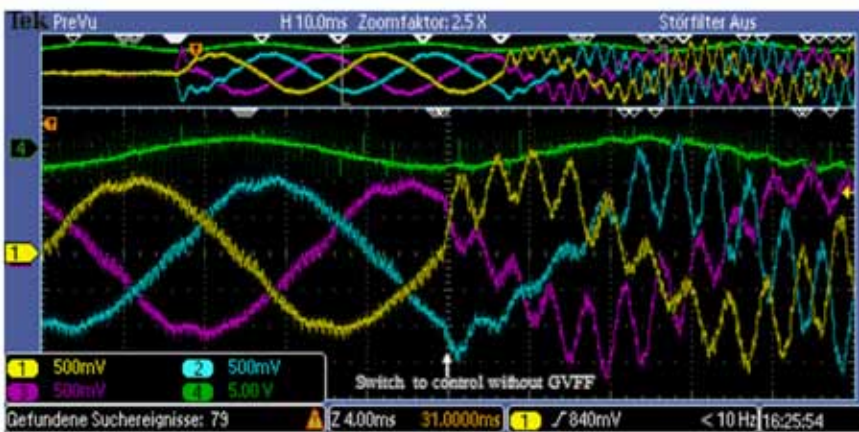

Figure 3 b: Current oscillations resulting from grid resonance [2]

### Summary

Within the project Smart Nord the Institute for Drive Systems and Power Electronics developed an analysed stationary and dynamic models for wind and solar energy sources. The current controller was analysed with respect to the influence of a variable grid resonance. This analysis was done considering cable capacitances and power factor compensation capacitances. It could be shown that controllers with voltage feed forward are in general less sensitive to grid resonances. The conventional power controller was analysed in direct and indirect configuration. Since a first extension with a derivative term did not lead to a simple model with locally known parameters, a new controller with a decoupling matrix was developed. With this improved extension, decoupled step responses could be achieved.

### References

- [1] Fuchs, F.; Pham, V. D.; Mertens, A.: Analysis of Grid Current Control in Consideration of Voltage Feedforward and Cable Capacitance Demonstrated on a Fully Sized Wind Turbine Installed in a Wind Park, IEEE Energy Conversion Congress & Exposition (ECCE), Denver, CO, USA, 2013, pp. 3325-3332
- [2] Fuchs, F.; Mertens, A.: Prediction and avoidance of grid-connected converter's instability caused by wind park typical, load-varying grid resonance, IEEE Energy Conversion Congress and Exposition (ECCE), Pittsburgh, PA, USA, 2014, pp. 2633-2640
- [3] Fuchs, F.; Dietz, R.; Garske, S.; Breithaupt, T.; Mertens, A.; Hofmann, L.: Challenges of grid integration of distributed generation in the interdisciplinary research project Smart Nord, IEEE 5th International Symposium on Power Electronics for Distributed Generation Systems (PEDG), 2014, pp. 1-7

# Control of Wind Power Stations as a Fictitious Turbine-Generator-System

Universität Bremen  
Institute for Electrical Drives,  
Power Electronics and Devices

Markus Schmidt, Bernd Orlik

Funding: German Research Foundation  
(DFG)  
Ref.Nr. DFG OR 81/17-1

Duration: 2010-2013

## Introduction

The development of renewable energy sources is constantly pressed ahead. But it is not only crucial how many wind energy farms are built, but also how every single wind power station behaves as seen by the power grid. At the moment thermal power plants are used to guarantee power grid stability. The kinetic energy stored in the plant's turbines and generators is used as important instantaneous reserve for grid stabilization. They also hold available control energy for seconds and minutes reserves. These reserves are released in case of a grid frequency or voltage disturbance.

The electrical feed of wind power stations to the power grid solely depends on wind speed and is maximized at all times. From an economical point of view this is the most profitable solution. But because of this they do not possess the ability for power grid control mechanisms. With an ever rising count of renewable energy sources replacing conventional power plants, there will be a lack of instantaneous and primary reserve power, which could lead to a destabilization of the power grid. Therefore it is necessary to include grid control features into wind power stations to enable them to contribute to ancillary services to stabilize future energy grids.

## Project Description

The power distribution system is shaped by all power plant generators that are connected to the power grid. With wind power stations replacing conventional power plants a feasible solution is to transfer the behaviour of the latter towards the former. The properties of a steam power plant, consisting of a turbine with a synchronous generator, have to be emulated by a state of the art wind power station with a fully-fed converter. By this, every wind power station can contribute to ancillary services to a certain degree, providing instantaneous reserve and primary balancing. Figure 1 gives an overview of the classifications for power grid reserves and controls.

Combined with the proposed control method, the components of a wind power station are able to emulate the behaviour of a turbine in a steam power plant. As controlling element the pitch angle is used to control the power conversion, analog to the main steam valve. By limiting the maximum power conversion a primary reserve can be held available at all times. The grid-tied converter is controlled by a fictitious electrical excited synchronous generator with amortisseur. This leads to a current profile similar to the dynamic behaviour of a power plant generator, as seen by the power grid. The implemented amortisseur is able to damp grid oscillations during load changes. By this all advantages of a steam power plant can be used by the new control method.

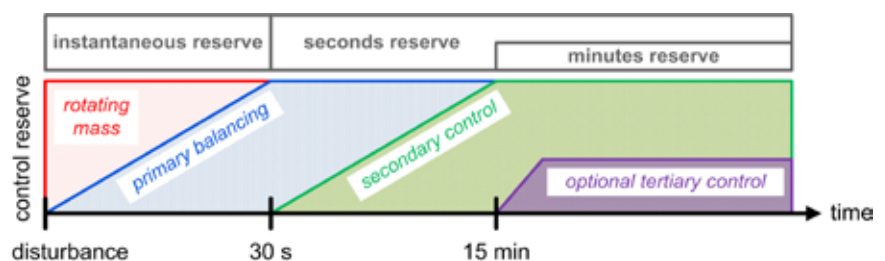

Figure 1: Classification of the different reserves in power grids

For this purpose a novel approach is proposed, which transfers the system management of today's conventional steam power plants to wind power stations with a fully-fed converter and a synchronous generator. The aim is that droop based control methods can be used and an instantaneous reserve can be provided by wind power stations. A fundamental difference to conventional wind power station control concepts was made: Control of the DC-link voltage is no longer done by the grid-tied converter, but by the generator-tied converter, using the synchronous generator with a connected wind wheel.

A power plant control is used to control rotation speed and excitation voltage to adjust the feed of active and reactive power.

This approach was tested successfully by simulations at first. For validation a laboratory test stand was developed and put into operation, which is shown in fig. 2. It consists of a torque controlled motor to emulate wind profiles, which is connected to a permanent magnet excited synchronous generator. A grid emulator is used to test the reaction of the grid-tied converter to reproducible disturbances.



Figure 2: Test bench with synchronous generator (30 kW) and induction motor (45 kW) as drive

First experimental analyses were carried out to verify the proposed method. Fig. 3 shows how the DC-link voltage is balanced after a 5 kW step load change. It can be seen that the response time from voltage drop to re-balancing is within tolerable boundaries.

## Summary

A novel control method for wind power stations allows adding ancillary services to renewable energy sources, where no hardware modifications are necessary. There is no need to modify the electrical or mechanical hardware of existing wind power stations. The proposed control methods can be implemented into existing systems by software changes only.

Simulation results showed that the new wind power station can emulate the behaviour of a conventional steam power plant. This was validated by laboratory experiments. The generator-tied inverter works analog to a steam turbine, where the pitch angle represents the main steam valve. The grid-tied inverter is controlled by a fictitious synchronous generator. The DC-link represents the shaft between both components and is stabilized by the generator-tied in-

verter. Standard control strategies are implemented for primary balancing over droops. The moment of inertia of the wind turbine is used as an instantaneous reserve during grid disturbances.

With the new control algorithm the wind power station has nearly same behaviour as a steam power plant, where well known control strategies can be used. Through this solution the wind power station can be adapted into the existing energy distribution system.

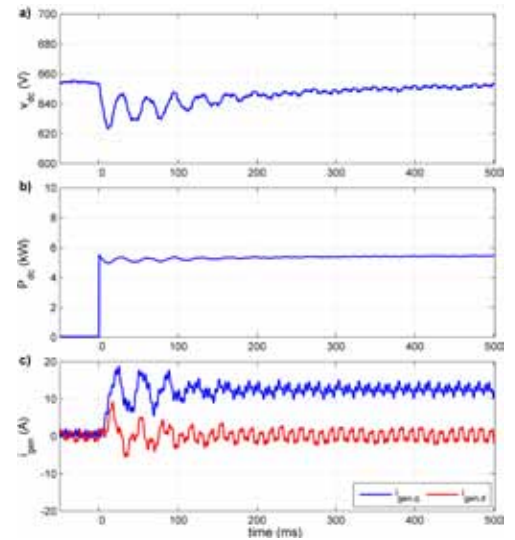

Figure 3: Behaviour of the new generator-tied inverter DC-link voltage control towards a resistive load step change of 5 kW.

- a) DC-link voltage  $v_{DC}$ , controlled by the inverter
- b) resistive load step change power  $P_{DC}$ , directly at the DC-link
- c) resulting controlled generator direct-axis ( $I_{gd}$ ) and quadrature-axis currents ( $I_{gq}$ ) to compensate the load step change

## References

- [1] Orlik, B.; Schmidt, M.; Florian, F.: Control of a wind power station with the strategy of a conventional power plant, IEEE EPQU 2011, Lisbon/Portugal, May 17th-19th 2011
- [2] Schmidt, M.; Fein, F.; Orlik, B.: Grid integration of a wind power station with control concept like in a steam power plant, Dewek 2012, Bremen/Germany, November 7th-8th 2012
- [3] Fein, F.; Schmidt, M.; Groke, H.; Orlik, B.: A Paradigm Change in Wind Power Station Control through Emulation of Conventional Power Plant Behaviour, Power Electronics and Applications (EPE) 15th European Conference, Lille/France, September 3rd-5th 2013

# Wind Power Ramp Event Prediction with Support Vector Machines

Carl von Ossietzky Universität Oldenburg  
Dpt. of Computing Science –  
Environmental Informatics &  
Computational Intelligence

Oliver Kramer, Nils André Treiber,  
Michael Sonnenschein

Funding: University of Oldenburg

Duration: 2012/6 – 2015/5

## Introduction

Important aspects for the integration of wind power into the grid are sudden and large changes known as wind power ramp events. In our project, we consider the wind ramp prediction task as data-driven statistical learning problem that can be solved based on measurements of wind power and wind velocities. Under the assumption that large wind data sets exist with high temporal and spatial resolution, machine learning algorithms can be employed to predict future situations. The main focus for solving this problem is based on support vector machines (SVMs), one of the state-of-the-art methods in machine learning. For new unknown wind situations, the SVM computes reasonable predictions, which are based on a previous training process. We introduce the wind power ramp event detection problem as classification problem, which we solve using SVMs. Wind power features from neighbored turbines are employed in a spatio-temporal classification approach. The problem of imbalanced training and test sets w.r.t. the number of no-ramp events is analyzed experimentally and the implications on practical ramp detection scenarios are discussed. Basis of the experimental analysis is the *Western Wind* data set by the US National Renewable Energy Laboratory (NREL).

## Project Description

A critical aspect for power grid stability when integrating wind is the occurrence of ramp events, i.e. sudden changes of wind power (up or down). In literature, ramps are not clearly defined [1] and may vary from turbine to turbine depending on locations and sizes (for parks respectively). Let  $p(t)$  be the wind power time-series of the target turbine, for which we determine the forecast. A ramp event is defined as a wind energy change by ramp height  $\theta \in (0, p_{\max}]$  from time step  $t \in \mathbb{N}$  to time step  $t + \lambda$  with  $\lambda \in \mathbb{N}$ , i.e. for a ramp-up event, it holds  $p(t + \lambda) - p(t) > \theta$ , for a ramp-down event it holds  $p(t + \lambda) - p(t) < -\theta$ .

We define the ramp prediction problem as the task to predict whether a ramp-up or a ramp-down event starts at time  $t$ , i.e. an energy change from time  $t$  to time  $t + \lambda$ . This problem can be defined as classification problem, for which we construct a pattern  $x_i \in \mathbb{R}^d$  from the wind power features of the target turbine and the surrounding turbines using the regression approach by Kramer et al. [2]. The ramp event serves as label  $y$  (0 for no-ramp, +1 for ramp-up, and -1 for ramp-down). Fig. 1 shows the construction of a pattern  $x_i$  based on the radius  $r$  around the target turbine (see also Kramer et al. [2]).

Besides the classifier accuracy  $\delta$ , i.e. the rate of correct classifications using indica-

tor function  $I$  to compare model output and label, we will employ two quality measures to evaluate the quality of a ramp prediction method. Let  $f(x_i)$  be the output of the classifier based on the observed wind pattern  $x_i$ . We define the following quality parameters for the prediction model:

- $f_t$  is the number of true ramp forecasts ( $f(x_i) = +1$  and  $y_i = +1$ ) or ( $f(x_i) = -1$  and  $y_i = -1$ )
- $f_f$  is the number of false forecasts ( $f(x_i) = \pm 1$  and  $y_i = 0$ )
- $r_m$  is the number of missed ramps ( $f(x_i) = 0$  and  $y_i = \pm 1$ )

Then,  $f_a = f_t / (f_t + f_f)$  is the *forecast accuracy*, which is an indicator for the ability of the model to be correct in case of predicting a ramp. The *ramp capture*  $r_c = f_t / (f_t + r_m)$  is an indicator for the ability of the model to hit each ramp. The balance of labels in training and test sets significantly influences the learning and the evaluation result. A well-balanced data set employs approximately the same number of patterns for all labels. For prediction of wind ramp events, this effect has an important implication for the ramp event prediction problem. First, we illustrate the imbalance problem for a classifier trained on a balanced training set, predicting the labels on an imbalanced set (see Fig. 2). The *ramp capture* result  $r_c$  is independent of the number of no-ramp patterns. The accuracy score of the classifier

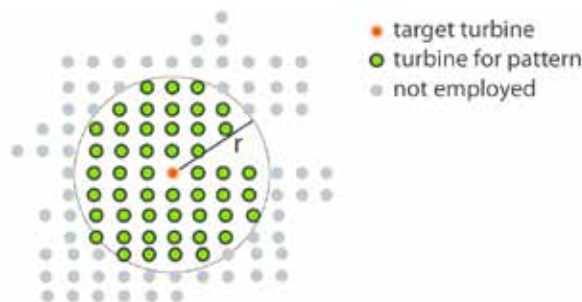

Figure 1: Illustration of feature construction based on  $d$  turbines in a radius  $r$  around the target turbine resulting in a pattern  $x_i \in \mathbb{R}^d$  of wind power measurements.

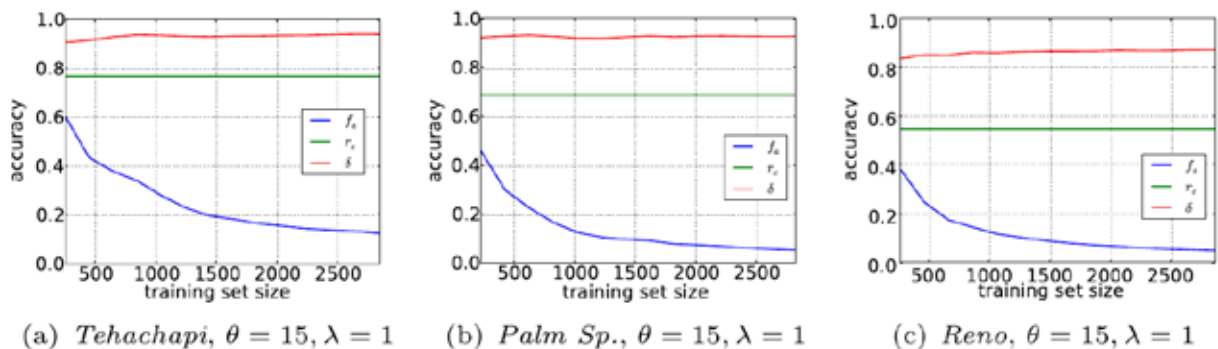

Figure 2: SVM ramp prediction with balanced training set and test set with increasing number of no-ramp patterns for references turbines in (a) Tehachapi, (b) Palm Springs, and (c) Reno with  $\theta = 15$  and  $\lambda = 1$ .

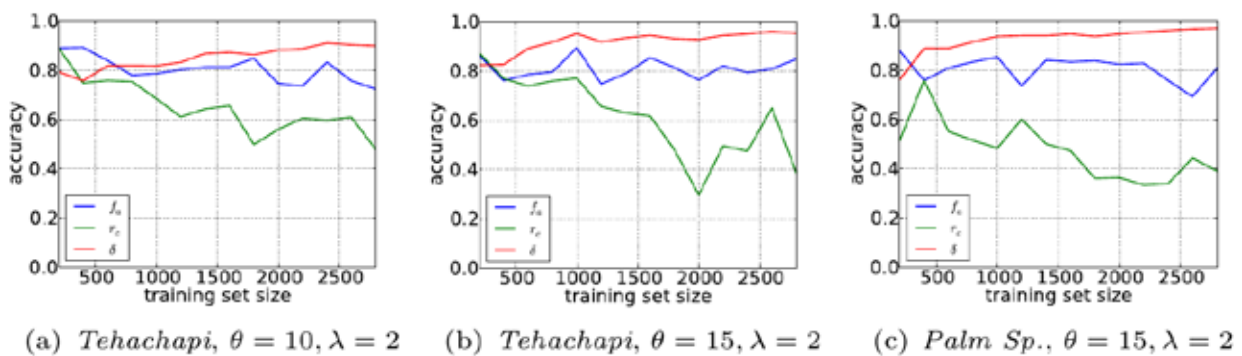

Figure 3: SVM ramp prediction with unbalanced training sets, i.e., increasing number of no-ramp patterns in *Tehachapi* with (a)  $\theta = 10$ ,  $\lambda = 2$ , (b)  $\theta = 15$ ,  $\lambda = 2$ , and (c) *Palm Springs* with  $\theta = 15$ ,  $\lambda = 2$ .

increases from 0.91 to 0.98. But we can observe that the forecast accuracy drops out significantly. The reason is that the number of false forecasts is dramatically increasing.

Fig. 3 shows the result of SVM-based ramp event predictions w.r.t. a training set with increasing number of no-ramps. We can observe that forecast accuracy  $f_a$  and the ramp capture  $r_c$  decrease with an increasing amount of no-ramps, while the accuracy score is even slightly increasing. But the forecast accuracy is still much better than in case of the balanced training set and the increasing test set. The reason is that the classifier better learns to distinguish ramp-events from each other and from no-ramp events with more examples in the training set. But the cost that has to be paid is the ramp capture  $r_c$ , as the number of true forecasts  $f_t$  decreases. The imbalance of class labels has a dramatic implication on the ramp prediction problem. Although SVMs turn out to be comparatively strong classifiers, the number of false positives is too

large in case of a strongly unbalanced test data set. In practical recognition scenarios, the number of no-ramps is significantly larger (about 150 to 300 times assuming 10-minute time steps) than the number of ramp events. Consequently, the accuracy of a classifier would have to exceed about  $\delta = 1 - 365/52560 = 0.995$  to allow at most one false alarm a day. The spatio-temporal model based on the turbine infrastructure is not sufficient to achieve such an accuracy rate, and more explaining features must be added.

## Summary

Although a high precision has been achieved in the classification process by SVM, the precision is not sufficient to reduce the number of false ramp event forecasts in practical applications. The reason is that ramp events are rare, which leads to an imbalanced data set. Ramp events may accidentally be predicted in normal situations. The only solu-

tion to this problem is a further increase of forecast accuracies: more data is necessary, e.g. with higher spatial and temporal resolutions. The combination with physical simulations, i.e. numerical weather predictions, may also be a possibility to increase the classifier accuracy.

## References

- [1] Focken, U.; Lange, M.: Wind power forecasting pilot project in alberta. Technical Report. energy & meteo systems, 2008.
- [2] O. Kramer, O.; Gieseke, F.; Satzger, B.; Wind energy prediction and monitoring with neural computation. *Neurocomputing*, 109:84–93, 2013.
- [3] Kramer, O.; Treiber, N. A.; Sonnenschein, M.: Wind Power Ramp Event Prediction with Support Vector Machines, in: Proc. International Conference on Hybrid Artificial Intelligence Systems (HAIS), 2014.

# Cooperative Demand Response in the Pacific Northwest: Mitigating Wind Power Ramp Events using a Distributed Control Concept

Carl von Ossietzky Universität Oldenburg  
Department of Computing Science –  
Environmental Informatics

Christian Hinrichs, Michael Sonnenschein

Funding: University of Oldenburg,  
German Academic Exchange Service

Duration: 02/2014 – 04/2014

## Introduction

The increasing pervasion of information and communication technology in the power grid motivates innovative research towards intelligent system control. In this project, a distributed control concept for the online scheduling of responsive loads is used as an alternative to the traditional centralized control. By distributing the decision making process, no global state information about the participating devices has to be gathered beforehand. The approach is applied to the mitigation of wind power fluctuations on a minute basis by controllable heat pumps. This is a joint work with the Institute for Integrated Energy Systems, University of Victoria, BC, Canada.

## Project Description

The volatility of renewable energy generation adds an increased supply-side uncertainty. Due to the natural variance of wind speeds, the feed-in of wind turbines is unpredictable on this scale. Demand response (DR) is a possibility to mitigate this problem. The project focuses on short term fluctuations of wind power supply. In par-

ticular, the reduction of variability in the residual load on a time scale of 1 minute using controllable residential heat pumps is targeted. The distributed approach COHDA (Combinatorial Optimization Heuristic for Distributed Agents) is employed [1]. The optimization target is announced by the utility operator in each time step and may constitute an arbitrary type of ancillary service regulation signal. According to [2], ancillary service types can be subdivided into load-following and regulation. The former usually addresses power balancing tasks on a scale of 5 to 30 minutes, while the latter responds to rapid fluctuations on a minute scale. By separating the power profile into base-load, load-following and regulation components, respective objective functions can be defined independently for each ancillary service type. We focus on the regulation aspect in the following. By assuming that base-load and load-following components are properly optimized and provided elsewhere, this allows us to formulate the regulation objective function based on ramp-rate only, which is defined as the change of load over time. So instead of tracking the actual power profile to achieve a supply-demand matching, we neglect the base-load and load-following aspects and configure the control strategy to minimize the power gradients of the residual load. For each time step  $k$ , given the the current wind power  $P_w(k)$  as well as the wind power  $P_w(k-1)$  and the aggregate load of the heat pump population  $P_l(k-1)$  at the previous time step, the target aggregate load for the current time step is calculated as:

$$P_l^{(\text{target})}(k) = P_l(k-1) - (P_w(k) - P_w(k-1))$$

In our study, both an uncontrolled reference simulation as well as a simulation with the COHDA scheduling approach

were performed. Consequently, we used the following metric to measure the performance of the simulations based on residual gradients. Given the residual load of both the reference case and the controlled case as  $res_r = P_w + P_l^{(\text{reference})}$  and  $res_c = P_w + P_l^{(\text{controlled})}$ , respectively, the performance of the control strategy for a time span  $[i, j]$  is calculated as:

$$ROF = \frac{(\sum_{k=i}^j |res_c(k) - res_c(k-1)|) \cdot 100}{\sum_{k=i}^j |res_r(k) - res_r(k-1)|} - 100$$

This way, ROF can be interpreted as percentage reduction of fluctuation in  $res_c$  with respect to  $res_r$  and thus gives us an easily understandable performance measure.

Fig. 1 shows the results for an exemplary simulation run. Wind power data was generated using the simulation model in [3], configured to represent a single 1.5 MW wind turbine. Similarly, a simulated population of 1000 heterogeneous houses equipped with air-source heat pumps was generated as described in [3]. Wind speed and temperature data was obtained from the NREL NWTC M2 Tower [4].

The upper chart depicts wind power (dashed line), dispatched heat pump power (solid line) as well as the maximal possible ramp-rate (both up and down) of the load population. The middle chart emphasizes the difference between wind power and dispatched power and thus depicts the remaining objective error of the optimization in the controlled case. The lower chart shows the actual residual load, for both the reference case and the controlled case. In this simulation, a performance of  $ROF=45.79$  was achieved, meaning that the fluctuations in the uncontrolled reference case could be mitigated by 45.79 %. Several rather large spikes are present



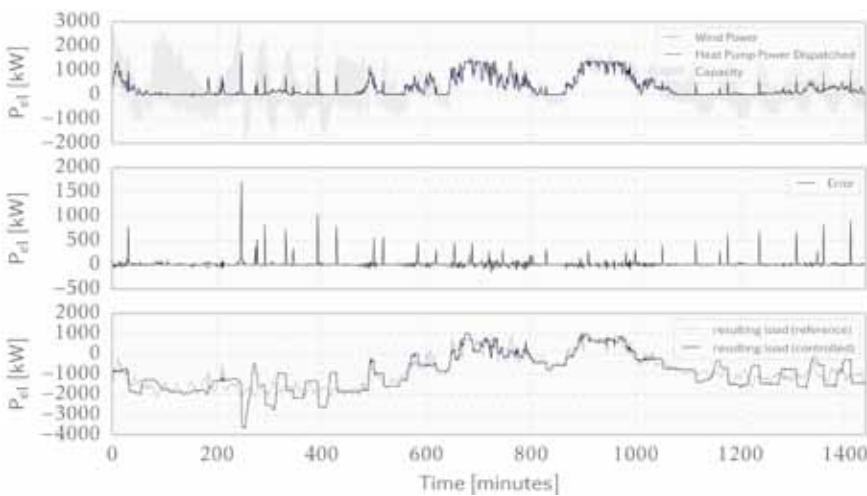

Figure 1: Results of a single simulation run: wind power, dispatched heat pump power and ramp-rate (upper chart), objective error (middle chart), residual load (reference and controlled, lower chart).

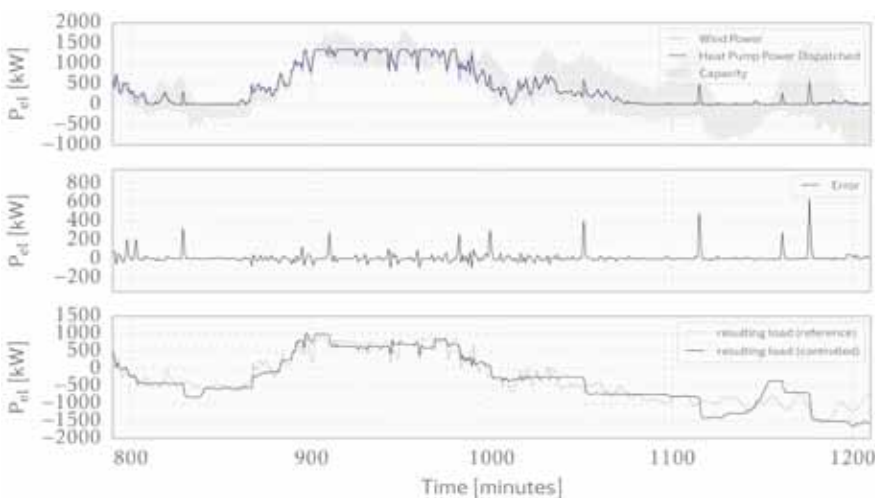

Figure 2: Results of a single simulation run, magnified part (time steps 800–1200).

in the visualization of the objective error (middle chart). These are almost evenly distributed during time intervals with no wind power. On the other hand, during intervals with considerably fluctuating wind power, the control strategy performs exceptionally well. For a closer look, a magnified part of the simulation (time steps 800–1200) is shown in Fig 2.

Here, the described effects are visible in detail. During intervals with highly fluctuating wind power, the dispatched load follows the target very closely. Further, even in the presence of a constant wind power, the dispatched load is generally able to follow the target, but is regularly interrupted by synchronized forced state switches.

## Summary

The results indicate that an accurate online scheduling of responsive loads without a centralized controller is possible. In its current state, the approach performs well for highly fluctuating target trajectories, but does not cope well with constant targets. However, simple extensions to the objective function should be able to overcome this problem, e.g. by simply disabling the control approach during such intervals, or by desynchronizing the load population continuously as proposed in [5].

## References

[1] Hinrichs, C.; S. Lehnhoff, S.; Sonnenschein, M.: COHDA: A Combinatorial Optimization Heuristic for Distributed Agents, in *Agents and Artificial Intelligence, Communications in Computer and Information Science*, vol. 449, J. Filipe and A. Fred, Eds. Berlin, Heidelberg: Springer Berlin Heidelberg, 2014, pp. 23–29.

[2] Hirst E.; Kirby, B.: Separating and measuring the regulation and load-following ancillary services, *Util. Policy*, vol. 8, no. 2, pp. 75–81, 1999.  
 [3] Parkinson, S. C.: *Managing Sustainable Demand-side Infrastructure for Power System Ancillary Services*, M.A.Sc., University of Victoria, BC, Canada, 2011.  
 [4] National Renewable Energy Laboratory (NREL), NREL: MIDC/National Wind Technology Center M2 Tower (39.91 N, 105.235 W, 1855 m, GMT-7).

[Online]. Available: [http://www.nrel.gov/midc/nwtc\\_m2/](http://www.nrel.gov/midc/nwtc_m2/). [Accessed: 01-Mar-2014].

[5] Hinrichs, C.; Vogel, U.; Sonnenschein, M.: Modelling and Evaluation of Desynchronization Strategies for Controllable Cooling Devices, in *6th Vienna International Conference on Mathematical Modelling (Mathmod 2009)*, 2009, pp. 220–225.

# Monitoring SBJ: Monitoring Suction Bucket Jacket

Leibniz Universität Hannover  
Institute of Geotechnical Engineering  
(IGtH)  
Institute of Structural Analysis (ISD)

Martin Achmus, Christian Schröder, Klaus Thieken, Tim Gerlach,  
Jann-Eike Saathoff (IGtH)  
Raimund Rolfes, Nikolai Penner, Andreas Ehrmann, Tanja Griebmann (ISD)

Partner: Ørsted A/S (formerly DONG Energy), Federal Institute for Materials Research and Testing (BAM)

Funding: Federal Ministry for Economic Affairs and Energy (BMWi)  
Ref.-no. 0325766A

Duration: 08/2014 – 07/2016

## Introduction

The research project “Monitoring SBJ” is a joint project between DONG Energy, Leibniz Universität Hannover (LUH), and the Federal Institute for Materials Research and Testing (BAM). It is based on measured data gathered from the comprehensive monitoring system mounted on the recently installed Suction Bucket Jacket prototype foundation, located at the offshore wind farm Borkum Riffgrund 1. The tasks of ISD are measurement data analysis of ambient vibration data during installation and operation and the improvement of a simulation model in terms of soil stiffness updating.

The overall goal of the project is the assessment of the design and installation feasibility of bucket foundations in the

German seas. The IGtH investigates the installation process, but also the overall soil-structure interaction by means of the foundation stiffness as well as the bearing capacity and deformation accumulation over time.

## Project Description

Driven piles are still state of the art for foundations of offshore wind energy converters. The pile driving process is tied with considerable hydro sound emissions regularly exceeding the limiting values. As an alternative to existing noise reduction methods, foundation types that can be built without pulsed piling noise are currently intensively being researched. In this context support structures like a jacket in combination with suction buckets are promising solutions that

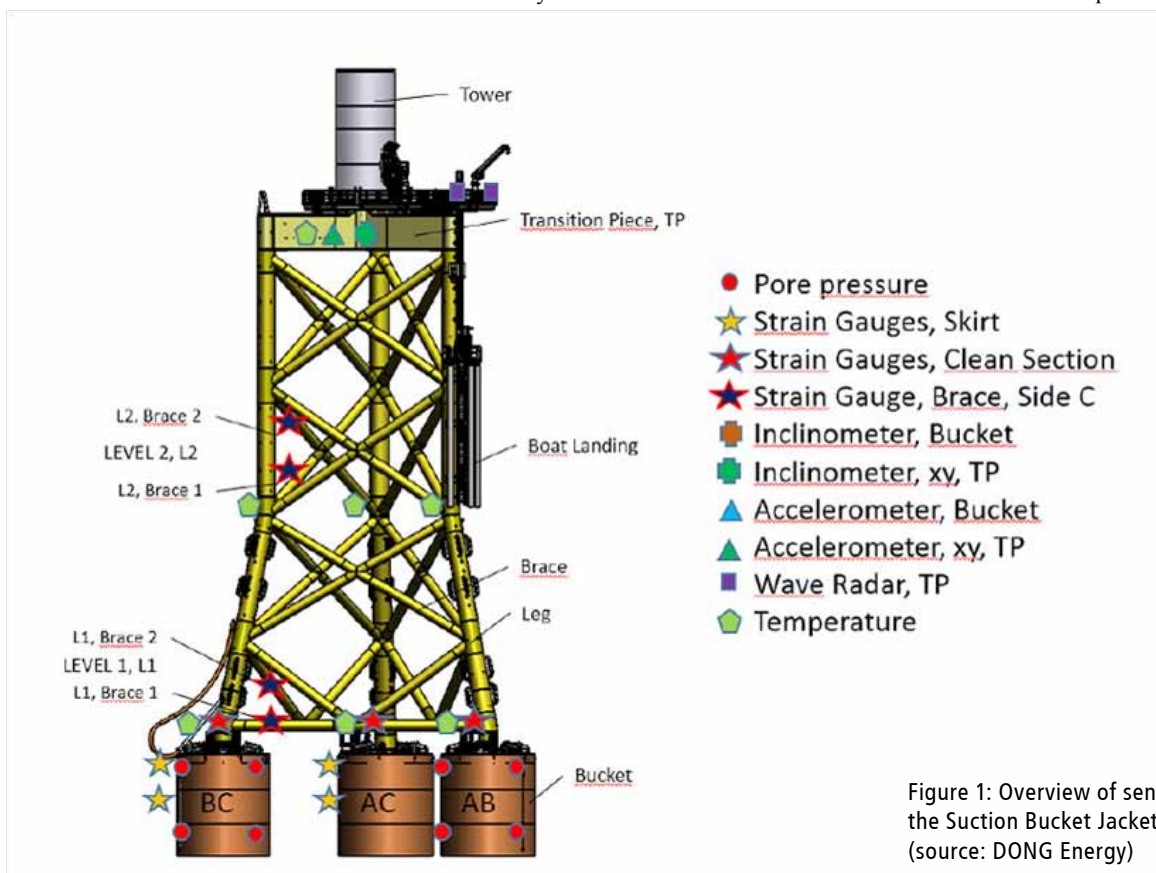

Figure 1: Overview of sensor positions at the Suction Bucket Jacket (source: DONG Energy)

impose only a minimal interference to the marine environment compared to gravity based structures.

This research project complements the research of the WindBucket project [1]. The collected extensive measurement data from 121 sensors at the Jacket and Suction Buckets during and after the construction process were prepared by data preprocessing and analysis for use in the work packages.

For this purpose a list of requirements was created in cooperation with all partners, which summarizes the required data analysis. The measurement data is necessary to validate all developed calculation methods and structural models. In particular, the movements of the Buckets and the Jacket described by measurements identify the real stresses and enable realistic global modeling.

In addition, underwater noise measurements were carried out during construction, which have provided evidence that the installation of the substructure with Suction Buckets is a low noise construction method. The measurements were carried out in 500 and 750 meters distance from the construction site at four measurement positions in two directions.

In the context of model validation of the structural model by the ISD also an efficient global modeling is pursued. An essential requirement for realistic determination of soil-structure interaction is an accurate description of the soil stiffness. To investigate the influence of soil stiffness on the global dynamics of the support structure, a finite element model of the structure was created.

In the design, there is a lack of practical experience with SBJ foundation structures under the typical load situations for offshore wind turbines. Consequently, there are neither standardized methods of calculation nor proof concepts available. Also validated structure models are missing that take the nonlinear and load history dependent soil structure interaction into account and with whom the bearing behavior due to cyclic and dynamic loads can be calculated. In this

project both the installation and the bearing behavior of the foundation and the overall structure were observed intensively by a monitoring system. The IGtH works with several numerical models on the understanding of the general mechanism for the installation of buckets as well as the general response of the foundations in terms of bearing behavior and soil-structure interaction.

### Summary

The ISD has started the scientific work on the Suction Bucket Jacket prototype. The first measurement data is available and analyzed for all partners after creating the list of requirements. During installation underwater measurements were performed to confirm the assumption of the low-noise construction method. The ISD has built a

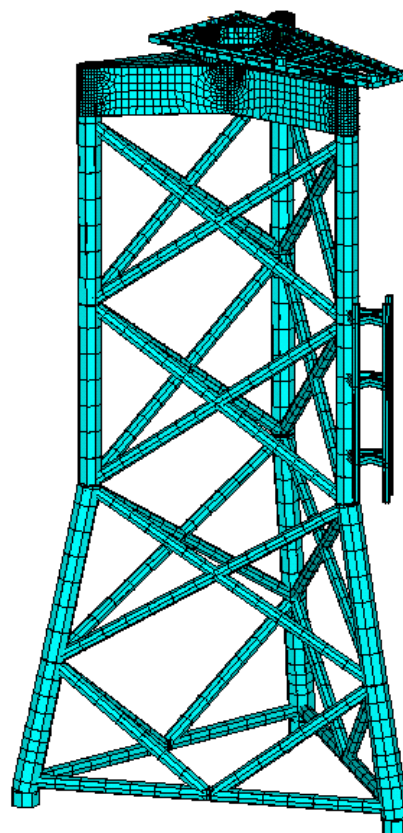

Figure 2: Finite Element Model of the Suction Bucket Jacket

finite element model of the entire structure, which enables adjustment of soil stiffness and validation of the structural model.

The IGtH has started to evaluate the soil exploration data delivered by Ørsted in order to derive a geotechnical soil model containing the relevant soil parameters for further calculations. The soil parameters are derived by CPT correlations. Furthermore, first numerical models have been generated, which capture the correct soil behavior and first response mechanisms are identified. Special care is taken of the investigation of the bearing behaviour of suction buckets under tensile loading in homogenous and especially layered subsoil. Besides pure axial tensile loading, inclined loads are accounted for.

Regarding the overall SBJ model, the nonlinear soil-structure interaction represents an essential part for both the design of the foundation as well as for the entire structure. Only a sufficiently accurate estimation of the foundation stiffness in the overall model allows the sustainable design of the structure by utilizing the existing soil resistances. Based on these needed features, the development of an innovative interface between the geotechnical model and the overall model has started. The work is done with a close interconnection between the joint project partners.

### References

- [1] Schröder, C., Ehrmann, A., Griebmann, T.K., Gottschalk, M., Rzeczkowski, P., Scholle, N., von der Haar, C., Achmus, M., Rolfes, R., Schaumann, P., Lohaus, L., Marx, S.: WindBucket – Suction Bucket Gründungen als innovatives und montageschallreduzierendes Konzept für Offshore-Windenergieanlagen, Abschlussbericht 0325406B, Leibniz Universität Hannover (2015)

# SHM\_Rotorblatt: System for Early Damage and Ice Detection for Rotor Blades of Offshore Wind Turbines

Leibniz Universität Hannover  
Institute of Structural Analysis  
(project coordination)  
Raimund Rolfes, Stavroula Tsiapoki,  
Tanja Griebmann

Institute for Information Processing  
Jörn Ostermann, Thomas Krause,  
Stephan Preihs

Funding: Federal Ministry for the Environment, Nature Conservation, Building and Nuclear Safety (BMUB)

Ref.Nr. 0325388

Duration: 12/2011 – 05/2015

## Introduction

The rotor blades of a wind turbine form a vital part of the overall structure and their continuous monitoring is therefore of great significance. The production of rotor blades is still mostly performed manually and leads to a varying quality. Defects due to fabrication, fatigue and extreme loads are the main reasons for the beginning and propagation of damage. Among the most often encountered damages are bondline failure between the upper and lower shell of the blade and delamination of the composite material. Both damage types can influence the load bearing behavior of the rotor blade and potentially disturb the operation of the wind turbine.

The annual failure rate of rotor blades is relatively low compared to other components of the turbine, such as the electrical system, but an occurrence of damage on the rotor blades causes a longer period of down time that can reach up to 5 days [1]. The standstill of the wind turbine results in great costs, which are even higher in the case of offshore wind turbines. Therefore,

the rotor blades should be continuously monitored and structural health monitoring methods have to be developed, in order to detect damage at an early stage and prevent the total loss of the blade structure.

Structural health monitoring contributes to early damage detection and to the improvement of competitiveness by preventing high maintenance and repair costs. Despite the existence of various monitoring systems, the visual inspections are still necessary, since the existing systems have not reached a satisfying level of reliability.

## Project Description

Within the preceding project „Adaption and application of an early damage detection and load monitoring system for composite rotor blades of wind turbines“ (FKZ 0327644B) a method based on the proportionality of the velocity in the position of maximum displacement and maximum dynamic stress was developed [2]. The aforementioned proportionality method could successfully be implemented during the fatigue test of a wind turbine rotor blade. During this fatigue test the existence and propagation of damage were successfully detected [3].

In the current project the Institute of Structural Analysis (ISD) in cooperation with the Institute for Information Processing (TNT) develop respectively a mechanical and an acoustic approach for structural health monitoring purposes. The objective of the current project is the improvement of the proportionality method and the extension of its application for ice detection, as well as its further development by additionally implementing an acoustic component.

Mechanical and acoustic data have to be gained both under test facility conditions

and at operating state. For this purpose a fatigue test on a 34 m rotor blade and measurements on a 50.8m blade of a wind turbine in operation are planned. The fatigue test includes an eigenfrequency test, an ice-accretion detection test, as well as a fatigue test in the edgewise direction until the development and propagation of damage. During the measurements in operation the mechanical and the acoustic system will be installed in a 3.4 MW wind turbine, in order to obtain data that correspond to the real operating conditions.

The extensions pursued in the current work concern the applicability of the proportionality method for non-harmonic excitation, which approximates the stochastic excitation applied to a rotor blade during the operation of a wind turbine, and the modification of the method for application to other quantities than velocity, i.e. for acceleration, as well as the applicability of the method using convenient sensors. The processing of data from a wind turbine in operation, which did not include any damage incident, indicated that the damage indicator of the proportionality method for the case of wind stochastic excitation generally remained at a constant level but at the same time presented high variations. In Figure 1 the proportionality factor that occurs from the maximum values of velocity ( $p_{max}$ ) and from the root mean square values of velocity ( $p_{rms}$ ) is presented for the case of operation of a wind turbine. Thus, there is a need for classification of the measured data, according to the different operating and environmental conditions.

Concerning the acoustic system, a detection algorithm using airborne sound was developed based on the signal analysis, which showed that airborne sound provides adequate features for cracking sound detection. The developed real-time capable detection algorithm is based on the com-

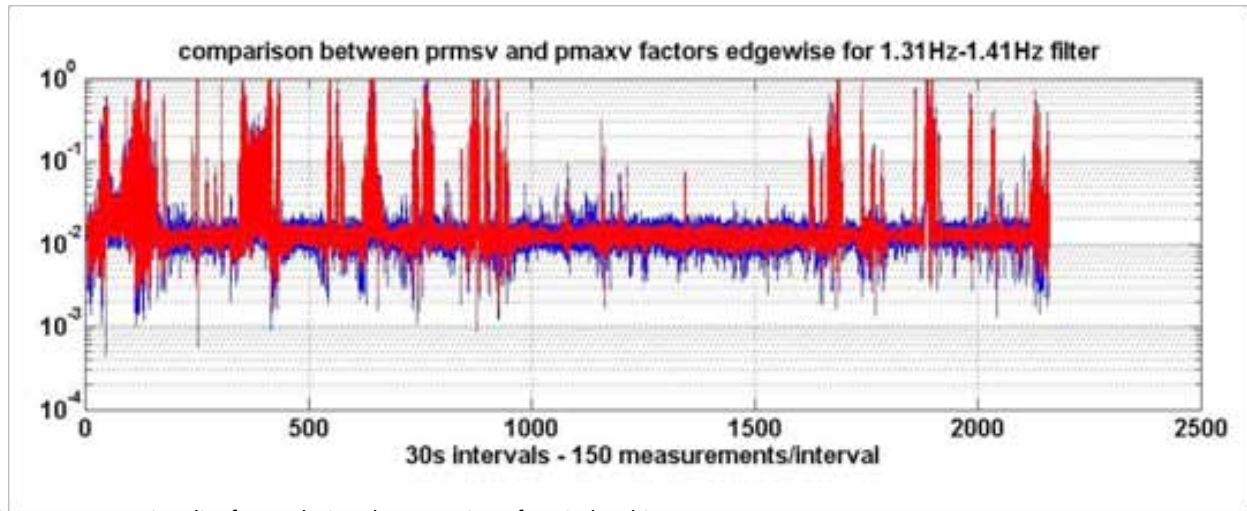

Figure 1: Proportionality factor during the operation of a wind turbine

parison of the input signal with a model of the cracking sound. The model describes a non-tonal sound with a sudden increase in power, a specific characteristic in power over frequency at the beginning of the impulse and a model for the decrease in signal power over time. To represent the characteristics of the cracking sounds, five audio features were designed and used. The algorithm was optimized and tested with the airborne sound recordings of the rotor blade test. In the first three days of the fatigue test the algorithm detected nine events per day. 79% of the events were cracking sounds. In the remaining 73 days of the fatigue test the algorithm detected about one event per day. The research results have been accepted for publication at the European Workshop on Structural Health Monitoring 2014 [4].

It is planned to analyze the correlation between cracking sound types and damage types and to improve the detection results of the algorithm with the upcoming measurement data. The measurement campaigns are also planned to give information about the limits and restrictions of the acoustic approach and to get data, which help to combine accurately the mechanical and the acoustic approach.

## Summary

The existence of damage on a rotor blade may be a reason for suspending the operation of the turbine or may even lead to the total loss of the rotor blade. Structural health monitoring of the rotor blades of onshore and especially offshore wind turbines is therefore of great significance, since the detection of damage at an early stage can prevent long downtimes and great repair costs. Within this project the extension and improvement of the existing proportionality method is being examined, while an acoustic component is simultaneously taken into account. The combination of the mechanical and acoustic approach is implemented, in order to offer a higher sensitivity to the monitoring system and avoid false alarms. For this purpose two measurement campaigns are planned: a full scale fatigue test in the edgewise direction and measurements in a rotor blade of a wind turbine in operation. Both mechanical and acoustic approach will be applied for the case of the fatigue test, in order to detect the existence of damage and for the case of measurements in a 3.4MW wind turbine in order to take into account the signals that occur under operation conditions.

## References

- [1] ISET, Germany, [http://www.iset.uni-kassel.de/pls/w3isetdad/www\\_iset\\_new.main\\_page](http://www.iset.uni-kassel.de/pls/w3isetdad/www_iset_new.main_page)
- [2] Gasch, R.: Eignung der Schwingungsmessung zur Ermittlung der dynamischen Beanspruchung in Bauteilen, PhD Dissertation, Technische Universität Berlin, Faculty of Mechanical Engineering, Berichte aus der Bauforschung Nr. 58 (1968)
- [3] Zerbst, S.: 2011, Global approach for early damage detection on rotor blades of wind energy, PhD Dissertation, Gottfried Wilhelm Leibniz Universität Hannover, Faculty of Civil Engineering, Institute of Structural Analysis, ISSN 1862-4650 (2011)
- [4] T. Krause, S. Preihs and J. Ostermann. Detection of Impulse-Like Airborne Sound for Damage Identification in Rotor Blades of Wind Turbines, accepted for EWSH July 2014

# European Wind Energy Master (EWEM) – Erasmus Mundus Master Course

Carl von Ossietzky Universität Oldenburg,  
ForWind

Martin Kühn, Joachim Peinke,  
Detlev Heinemann, Moses Kärn

Funding: Erasmus Mundus programme  
of the European Community (EACEA –  
Executive Agency Education, Audiovisual  
and Culture)

Ref.: 520316-1-2011-1-NL-ERA MUNDUS-  
EMMC

Duration: From 01 January 2012 for  
5 biennial editions of EWEM (2012-2014,  
2013-2015, 2014-2016, 2015-2017, 2016-  
2018)

## Introduction

ForWind is co-founder of the European Wind Energy Master (EWEM), an Erasmus Mundus Master Course supported by the European Commission. The consortium operating the European Wind Energy Master is composed of four universities:

- Coordinator is the Delft University of Technology (TU Delft)
- Technical University of Denmark (DTU)
- Norwegian University of Science and Technology (NTNU)
- ForWind Institute at the Carl von Ossietzky Universität Oldenburg (UniOL)

This consortium is teamed up by more than 40 associated partners from wind energy research institutions, companies, and NGOs. Leibniz Universität Hannover is one of them.

## Project Description

The EWEM- European Wind Energy Master is an advanced research oriented 2 year (120 ECTS) master course with four areas of specialization:

- Wind Physics
- Rotor Design
- Electric Power Systems
- Offshore Engineering

The students acquire knowledge in theoretical and applied sciences underlying wind energy systems, and specific competencies necessary to operate in the chosen area of specialization. EWEM prepares graduates for a career in research, both in industry and in academia, and is closely linked to the research taking place at the four universities. Thus, the specialization tracks are offered by the four universities according to their particular main field of research, as shown in Fig. 1.

EWEM students receive double-degrees from the universities operating the tracks. In the wind physics track these are the MSc Engineering Physics from the University of Oldenburg and the MSc Wind Energy from the Technical University of Denmark (DTU).

The first cohort of EWEM students started in October 2012 with a total number of 39 students, and the following cohorts had 36 and 37 students respectively. Table 1 gives an overview of the student numbers per track.

The European Commission's Erasmus Mundus programme is a cooperation and mobility programme that aims to enhance the quality in higher education between Europe and the rest of the world. Erasmus Mundus is a prestigious quality label and provides support to higher education institutions, individual students, researchers

and university staff and any organisation active in the field of higher education. Competition has been strong: in July 2011 30 proposals, including EWEM, were selected from a total of 177. Selected master courses receive funding for scholarships and fellowships for students and visiting scholars.

## Summary

The European Wind Energy Master (EWEM) is a cooperative master course supported by the European Commission's Erasmus Mundus programme. ForWind/University of Oldenburg is member in the consortium operating the programme. Since the start in 2012 three cohorts of students have been participating with a total number of 111 students.

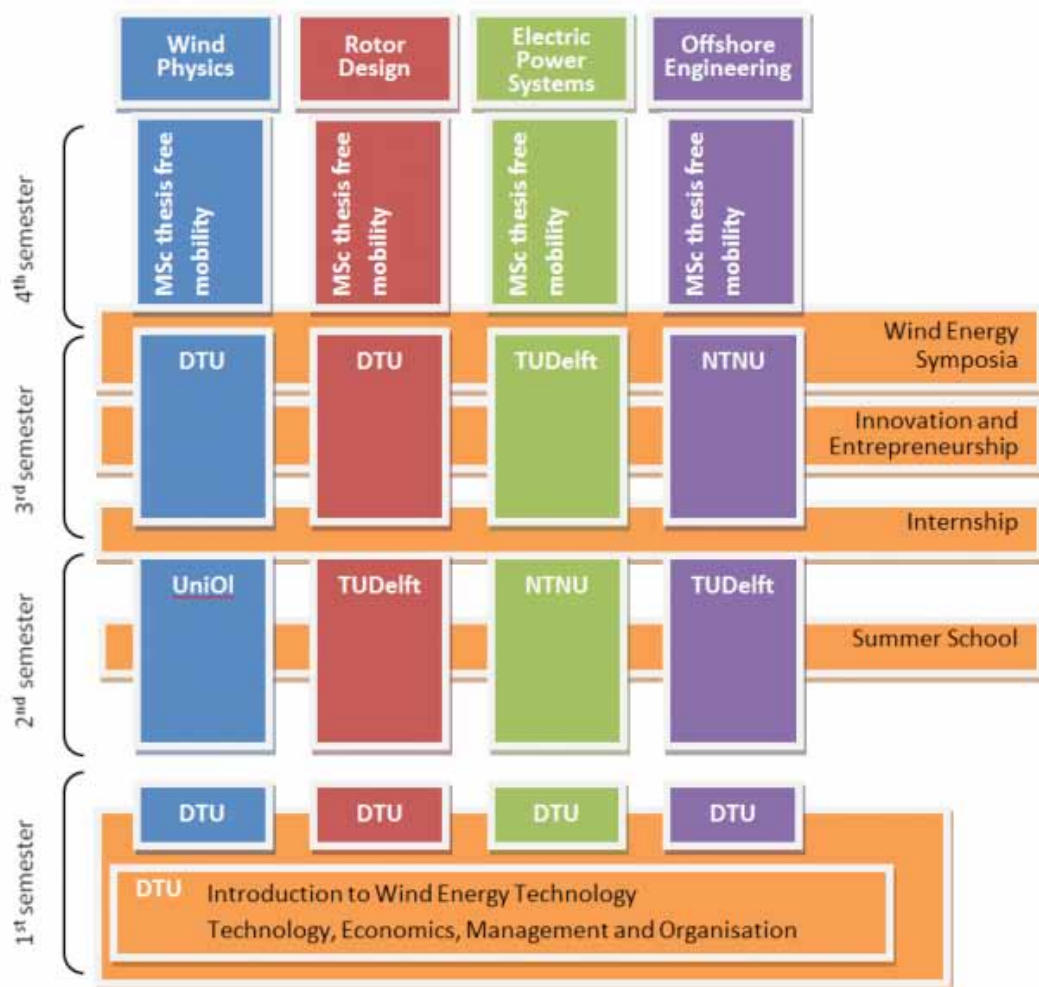

Figure 1: Structure of the European Wind Energy Master (EWEM). Abbreviations: Delft University of Technology (TU Delft), Technical University of Denmark (DTU), Norwegian University of Science and Technology (NTNU), Carl von Ossietzky Universität Oldenburg / ForWind (UniOL).

	Rotor Design	Wind Physics	Electrical Power Systems	Offshore Engineering	Total
1st cohort	17	5	4	11	37
2nd cohort	19	1	9	7	36
3rd cohort	17	4	7	9	37

Table 1: Number of students in EWEM and in its four tracks.

Link:  
Further information:  
[www.windenergymaster.eu](http://www.windenergymaster.eu)

# Master Programme on Wind Energy Engineering

Leibniz Universität Hannover, ForWind

Claudio Balzani, Andreas Reuter,  
Raimund Rolfes

Duration: Since 10/2011

## The Need for Experts

The wind energy sector has developed from a niche industry into an internationally operating, professional economic sector, so that well qualified engineers are in high demand. Specialist knowledge and skills from all areas of engineering are needed, as are an understanding of the systems involved and an interdisciplinary way of thinking.

Engineers in the wind energy sector are faced with a wide range of challenges. The rapid growth of this industry calls for a high degree of innovation and creativity. The close alliance of different engineering disciplines and also non-technical areas requires interdisciplinary working practices and the relevant training. The large bandwidth of required engineering skills is highlighted by a large diversity of possible employer, which are e.g.:

- Wind turbine manufacturers
- Energy suppliers
- Project developers
- Banks, insurances and investors
- Engineering offices or certification bodies
- Municipal building authorities, local government and administration
- Suppliers from the mechanical engineering, electrical engineering, or construction industry
- Research institutions.

## Become an Expert – in Hannover

The Wind Energy Engineering master at Leibniz Universität Hannover (LUH) is the first university master's programme in this field offered in Germany. The associated Master's degree (MSc.) qualifies for traditional civil, electrical or mechanical engineering professions, but also for interdisciplinary expert positions focusing on wind energy. It combines all the required aspects in an interesting and varied range of studies. Aerodynamics, power electronics, numerical simulation methods, steel construction – no matter what, students in the master's programme are taught an extensive range of subjects. Students will make use of the most up-to-date scientific

methods and will experience heavily practice-oriented education and interdisciplinary collaboration with other fields in the natural sciences and engineering.

As experience shows, students benefit from a medium-size team of fellow students that is highly networked, cooperative, and helpful. Besides classical lectures and tutorials special features are offered by the institutes, such as the popular Composite Labs, where students laminate their own little composite samples and rotor blades inlabs of our test center support structures and of our major research partner, the Fraunhofer Institute of Wind Energy and Energy System Technology in Bremerhaven, see Fig. 1.



Figure 1: Student trimming the trailing edge of the small rotor blade model laminated during the Composite Lab (picture provided by Daria Horte, 2012).



## Content and Structure of the Wind Energy Engineering Master

The degree in Wind Energy Engineering at LUH is organized as a 4 semester consecutive Master's Programme comprising 120 credits. The objective is to provide students with extensive basic knowledge to prepare them for professional life and to illustrate the responsibility of the wind energy engineer through practice-oriented education. Through corresponding course options, students will be given the opportunity to specialize in different areas in order to successfully progress to professional life as specialists.

Students with a Bachelor degree in an engineering topic are evaluated and – if accepted – classified in the basic competences civil (CE), electrical (EE), or mechanical engineering (ME). The lectures are subdivided into interdisciplinary (50 credits) and

competence-specific (70 credits) contents, see Figure 2. Depending on their basic competence, students can choose from the following four competence fields of their specialization, which define the competence-specific contents:

- Dimensioning of load-bearing structures (CE)
- Electrical energy conversion and grid connection (EE)
- Project planning, production, construction and operation (CE + ME)
- Wind and mechanical energy conversion (ME)

## Required Skills and Application Procedure

Applicants must hold a Bachelor degree in civil, electrical, or mechanical engineering. A Bachelor degree in a related engineering

discipline is also welcome. Besides of that, the demanding tasks in Wind Energy Engineering require creativity and imagination, awareness of responsibility, decisiveness and assertiveness. Enjoyment of problems in mathematics and natural sciences will make the degree easier.

A good working knowledge of German is required. Selected optional courses are offered in English. English skills are therefore recommended, but not compulsory.

The Wind Energy Engineering Master can be started in winter and summer semesters. The application deadlines and general information about the application procedure can be found here:

<https://www.uni-hannover.de/en/studium/studienfuehrer/windenergie>

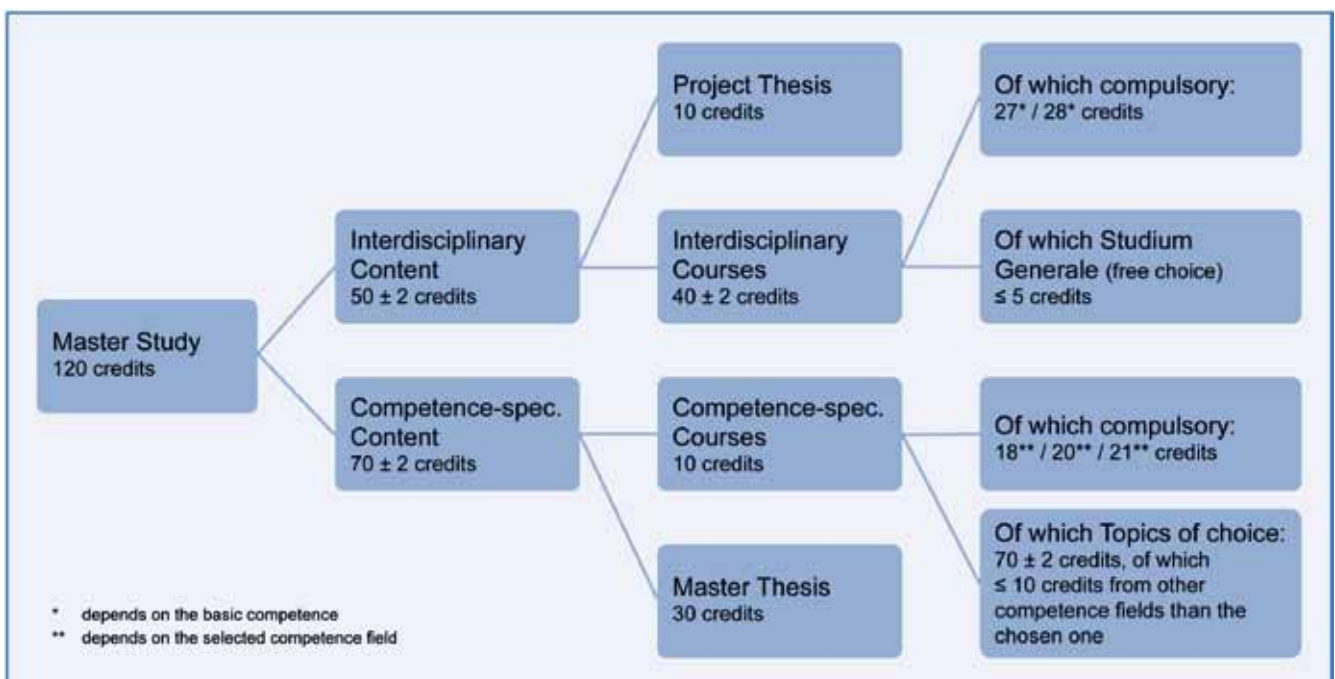

Figure 2: Structure of the Wind Energy Engineering Master Programme with interdisciplinary and competence-specific contents.

# Continuing Studies Programme Wind Energy Technology and Management

Carl von Ossietzky Universität Oldenburg,  
ForWind

Moses Kärn, Christoph Schwarzer

Partners: Wind Energy Agency WAB,  
City of Oldenburg

Funding: Participants' fees and co-spon-  
soring by Bremer Landesbank, GE Wind  
Energy GmbH, WSB Service GmbH

## Introduction

In its eighth and ninth years of existence the *Continuing Studies Programme Wind Energy Technology and Management* ("Windstudium") is still a unique offer for professionals with academic background to obtain part-time professional education. The programme has been developed in close cooperation between ForWind and WAB. Numerous partners from research, education, industry, and businesses in the field of wind energy supported the realization of this continuing academic education for professionals. The programme is funding sponsored by GE Energy, Bremer Landesbank, and WSB Service GmbH.

## Description

Wind energy is a highly innovative and interdisciplinary industry sector whose further successful development will be closely tied to the availability of highly skilled and educated experts from various backgrounds. Because of the complex nature of the field part-time education is an important instrument to provide professionals with high-level systematic know-how and interdisciplinary understanding of wind energy technology, projects, and economic issues.

The *Continuing Studies Programme Wind Energy Technology and Management* is especially designed to support companies of the wind energy sector, and is directed to professionals in the field as well as to those who wish to enter this field. It offers comprehensive systematic understanding of wind energy projects from scientific grounds to technical, legal and economic realization, as well as skills in planning and project management.

The programme offers a mix of learning methods and is therefore designed to fit the requirements of professionals. It: self-study of reading materials, a two-day seminar once every month, and project work in teams. The total duration of the programme is eleven months. The certificate "Certified Wind Energy Expert" is issued by the University of Oldenburg upon successfully passing the examinations.

The realization of wind energy projects requires that experts from a variety of differently disciplines work closely together. This innovative program of study is one that addresses exactly such interdisciplinary challenges, and furthermore fosters a 'know-how-transfer' from acknowledged experts in the field and from Universities, thus providing current and expert knowledge. The program's study materials were developed in partnership with the University of Oldenburg's continuing education experts and satisfy the highest of academic didactic standards.

The interdisciplinary approach is the central theme that the program is based upon and is represented by the following special characteristics.

**Group Dynamics:** The selection process will be based on bringing together a group of people with a wide range of experience in their academic and occupational areas,

be it technological, planning management, administration, or law. Thus the student group's line-up will reflect the heterogeneous profiles, which are often found within a company's typical departmental work group.

**Project Work:** For the duration of the program an eight-person team will work on a complex wind energy project. During this process, questions will arise relevant to all areas of the curriculum and the students will collectively resolve these issues and the project's tasks. The project work will provide a lot of practical experience, which will reflect what the students have been learning, and 'real' experience in communication with experts from a variety of disciplines.

**Teaching Material:** The course pack is divided into basic and speciality areas. The basic areas are obligatory for all of the students and within the specialized areas half will be examinable. The students will choose the speciality areas they wish to be examined upon, therefore allowing them to focus on their personal areas of expertise and interest.

The programme is constantly evaluated and further developed in close consultation with a wind energy advisory board that meets annually to advise the programme's administrators, and to arrange the co-instructors and guest speakers. The co-instructors are experienced representatives from the industry who present concrete aspects and expert knowledge, which complements the main instructors' teachings.

The administrators of the *Continuing Studies Programme in Wind Energy Technology and Management* operate an active network of alumni in order for the students to continue to stay in touch with each other, to assist them in the exchange of professional information, and to support further



Field trips, here to the construction site of a wind farm in Oldenburg, enrich the practical experience of students in the *Continuing Studies Programme Wind Energy Technology and Management*. (Photo: ForWind)

continuing education possibilities. Yearly alumni meetings take place in Oldenburg or Bremerhaven. In 2013 the first exclusive two day alumni journey to Brande, Esbjerg and Kiel took place.

After seven fully booked course cycles (24 students each year), the demand has slightly decreased: the eighth course had 22 graduates and the ninth course was finished by 17. Nevertheless, the programme has consolidated its position in the market.

The start of the ninth course is in September 2014 (application deadline June 30th 2014).

### Summary

The Continuing Studies Programme Wind Energy Technology and Management is especially designed to support companies and professionals of the wind energy sector. After nine years of successful op-

eration it has consolidated its position as well-established programme of continuing academic education in the wind energy sector even if the numbers of applications and participants has been declining. The tenth course will start in September 2015.

Link:

[www.windstudium.de](http://www.windstudium.de)

# Continuing Studies Programme Offshore Wind Energy

Carl von Ossietzky Universität Oldenburg  
ForWind

Moses Kärn, Juliane Reichel,  
Christoph Schwarzer

Partners: Wind Energy Agency WAB, City of  
Oldenburg

Funding: Participants' fees and co-spon-  
soring by Bremer Landesbank, nkt cables  
GmbH, Nordwest Assekuranzmakler GmbH  
& CO KG, and Siemens AG

## Introduction

Offshore wind energy is developing into a full-size industry sector. The complexity and size of offshore wind farm projects, the speed of innovations, and the dynamic change processes, along with the high risks involved are factors that put the jobs of experts and managers on a very high level of responsibility. Thus, offshore wind has a need for highly skilled specialists with multi-disciplinary know-how and experience. Structured and specialized academic study programmes with offshore wind energy focus are only slowly emerging and will still not be able to meet the market's growing demand. Thus, ForWind, the Wind Energy Agency WAB and the City of Oldenburg had joined forces in a project to develop the new professional part-time studies programme Continuing Studies Programme Offshore Wind Energy in 2011. In 2013 the first pilot course has been finished in May, and the second run started in October.

## Project Description

The Continuing Studies Programme Offshore Wind Energy is a part-time studies programme using a "blended learning mix" of distance education, e-learning, classroom teaching, and project work. The pilot course in 2012/2013 was operated with 25 participants, and the second course in the academic year 2013/2014 started with 9 participants. While the first pilot course could be successfully operated, its further establishment on the market for lifelong learning programmes proved to be difficult – most likely due to the economic developments in the offshore wind energy industry. Nevertheless, the second course could be started, and the nine participants finished the course in June 2014.

The design and curriculum of the programme have to be flexible in order to be able to react to new industry and market developments. The programme intends to give an "overview" and interdisciplinary understanding of projects with very high complexity, high costs and high risks – a challenging demand for the design of a continuing studies programme. Therefore the focus of the curriculum is on interface, risk and project management. And, in the offshore wind industry formerly separate industries and businesses have to come together, merge, or cooperate: the wind industry meets the maritime sector, both having very peculiar business traditions like wind turbine manufacturing or charter contracting, and that has caused a lot of problems for both sides.

A central aim of the Continuing Studies Programme Offshore Wind Energy is to also support the companies and their staff in the development and change process that they are facing when they are involved in offshore wind energy projects. The curriculum of the Continuing Studies Programme Offshore Wind Energy introduces

the students systematically to the technology and the management of offshore wind energy projects – e.g. offshore technology, maritime environment, project development, finance, insurance, logistics, installation, operation and maintenance – and puts these separate pieces of a puzzle into the whole picture.

The syllabus is divided into five modules: Offshore Conditions and Wind Farm Design, Project Development, Offshore Wind Farm Components and Procurement, Offshore Wind Farm Logistics and Installation, and Offshore Wind Farm Operation. These five modules correspond to five classroom instruction periods that are organised on a bi-monthly schedule. They not only provide in-depth insights into all phases of an offshore wind farm's life cycle, but simultaneously form the substantive framework for case study work.

In order to enable students to learn in different ways while they stay in their jobs the course uses a well-established portfolio of different learning and teaching methods, a so called "blended-learning" mix: classroom instruction periods once every two months, private study periods, internet based support, and case study work in project teams.

The project orientation is essential for the programme. The participants come from different professions – be it a technical, commercial or legal background –, and project work in interdisciplinary teams provides a perfect learning environment for the students. The programme fosters professional skills which are needed in the highly dynamical business of offshore wind energy. This puts high expectations on the professional skills such as multi-disciplinary expertise, management skills and acting on an international level. By working on praxis-oriented case studies those skills are directly trained.

During the nine month period of the programme participants and lecturers can intensively network. Graduates of the Continuing Studies Programme Offshore Wind Energy are organized in an alumni work which supports professional exchange and support. In November 2013 a two-day field-trip to the manufacturing site of Siemens Wind Power and the Port of Esbjerg was accomplished for alumni.

The start of the third course in October 2014 could not take place because of the

number of applications. For 2015 we are planning to integrate international partners from Denmark and UK to promote the programme in these countries.

### Summary

The Continuing Studies Programme Offshore Wind Energy is especially designed to meet the needs of the growing offshore wind energy industry. It teaches experts and managers on academic level in the dif-

ferent fields the necessary know-how to improve the management of complex offshore wind farm projects.

The programme covers all specific offshore wind energy topics from technical, legal and economic points of view.

Special attention is given to the whole life cycle of an offshore wind farm and the complex management challenges.



Field Trip to Esbjerg,  
Continuing Studies Programme Offshore Wind Energy 2013/2014

### References

[www.offshore-wind-studies.com](http://www.offshore-wind-studies.com)

# mint.online: Certificate Programme in Advanced Wind Energy (AWE)

Carl von Ossietzky Universität Oldenburg,  
ForWind

Martin Kühn, Andreas Schmidt,  
Moses Kärn

Partner: Fraunhofer Gesellschaft München,  
FernUniversität Hagen, Universität Kassel,  
Universität Stuttgart, NEXT ENERGY (EWE-  
Forschungszentrum für Energietechnologie  
e. V., Oldenburg).

Funding: Federal Ministry of Education and  
Research (BMBF)  
Ref.-Nr. (Förderkennzeichen): 16OH11042;  
(Kassenzeichen: 810302523747)

Duration: 10/2011 – 03/2015

## Introduction

The University of Oldenburg is one of the contributors to the project "mint.online – Aufbau berufsbegleitender Studienangebote in MINT-Fächern" (English: "mint.online – Establishing Extra-Occupational Study Programmes in STEM Subjects"). mint.online is one of 26 projects funded by the German Federal Ministry of Education and Research (BMBF) under the framework "Aufstieg durch Bildung: Offene Hochschulen" (English: "Advancement through Education: Open Universities"). The aim of this framework is to improve the position of German universities in the education market for continuing academic education in the fields of mathematics, computer science, natural sciences and technology (STEM-subjects; German acronym: MINT).

mint.online is a joint project by Carl von Ossietzky Universität Oldenburg, Fraunhofer Gesellschaft München, FernUniversität Hagen, Universität Kassel, Universität Stuttgart, and the research institute NEXT ENERGY (EWE-Forschungszentrum für

Energietechnologie e. V., Oldenburg). The project is managed by the Center for Long Life Learning (C3L) at the University of Oldenburg. Within mint.online, nine study programmes are developed. Collaboration within mint.online is organized along cross-sectional project groups – i. e. management, educational and technical realization, instructional design, online teaching technologies.

All mint.online programmes are designed as internet based "blended-learning" courses with a mix of online based self-instruction and classroom teaching periods. Due to their design they are especially attractive to non-traditional students, i. e.:

- management trainees and future executives, who want to study parallel to their job,
- employees currently on family leave, or unemployed who want to return to the job,
- bachelor graduates with job experience who want to proceed to a master degree.

One of these programmes is the Certificate in Advanced Wind Energy (AWE).

## Project Description

The certificate programme "Advanced Wind Energy – Computational Fluid and System Dynamics" (AWE) addresses electrical and mechanical engineers and physicists with a graduate degree or equivalent. Graduates with these backgrounds can take part in this programme, if they e.g. want to get a specialization for wind energy after their degree or want to change their industrial sector. The certificate programme AWE will be offered worldwide in order to educate available, highly qualified employees for research and development in the field of wind energy utilization.

The structure of AWE includes a bridge module which is intended to build up the basic knowledge for all students (see Fig. 1). After this, the students can choose between two specialization tracks: Energy Meteorology or Wind Energy Systems. The final extension module is intended to teach the handling of data and show practical examples of measurement and research. The collaboration within mint.online offers possibilities to gain synergetic effects by mutual use of course modules. This ap-

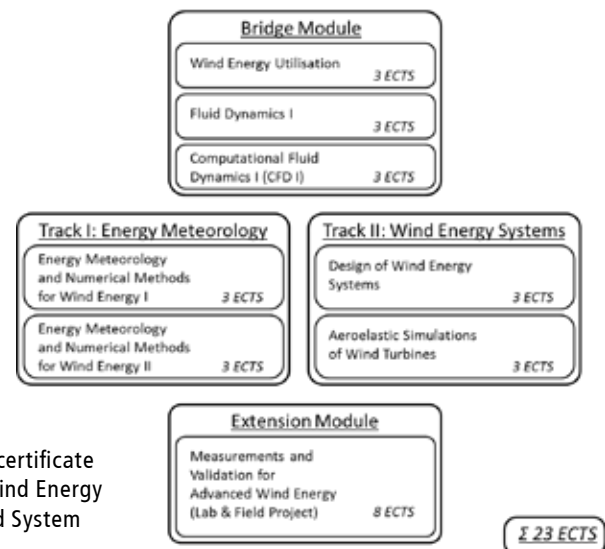

Figure 1: Structure of the certificate programme "Advanced Wind Energy – Computational Fluid and System Dynamics" (AWE)

plies also for the AWE programme of ForWind: Its modules – as well as those of the Certificate Programme Decentralized Energy Storage Systems (DEES) of NEXT ENERGY – will become also elective courses of the master programme "mint.online Renewable Energy" ("MORE", University of Oldenburg; see Fig. 2).

Therefore, a close collaboration among these three programmes exists since 2012 and continued in 2013 and 2014 successfully. This collaboration allows for

- improved coordination and balancing of the study material,
- planning of joint propaedeutic courses,
- joint commissioning of study materials or translations, and
- joint marketing and public relations.

## Project Development

During 2013 study material for the courses has been developed. The offered modules of the programme are based on the lectures and seminars that are regularly held by the institute of physics of the University of Oldenburg. The start of the first pilot course, Computational Fluid Dynamics, is prepared for summer term 2014.

In 2013 the AWE project of ForWind took part in the central project meeting in Kassel (September), Workshop meetings (26-27th March in Oldenburg, 18th October in Oldenburg) and several online webinars. Additionally, an online training for mentors given by the instruction design group in order to prepare for the online courses was completed. In 2014 the course books and exercises have been further developed. In summer semester 2014, a pilot course of the module "Computational Fluid Dynamics" (CFD) has been executed. At the same time, pilot courses of the above mentioned programmes MORE and DEES took place. A joint promotion for these programmes was developed (information flyer, poster, presentation at the job and education fair „zukunftsenergien nordwest 2014“).

The pilot course of CFD had applicants from all over the world. Many of the par-

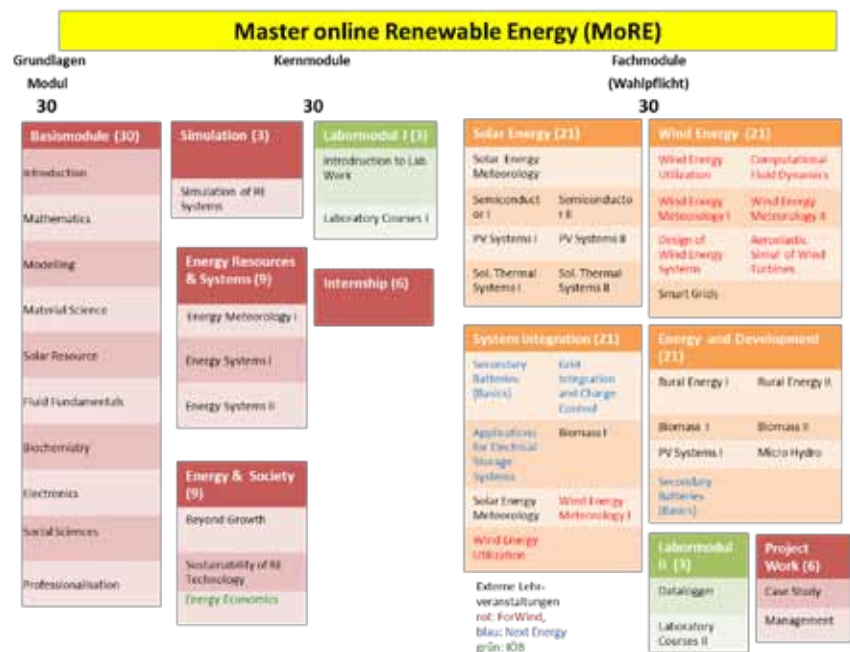

Figure 2 : Integration of the two certificates AWE of ForWind (red letters) and DEES of NEXT Energy (blue letters) into the master programme MORE

ticipants were alumni of the Master "Post-graduate Programme Renewable Energy (PPRE)" of the University of Oldenburg. The other participants obviously have searched the internet for this kind of distance learning offer. The pilot course of CFD has been evaluated and is currently updated for the re-run. The online learning platform for this course was provided by the Center for Lifelong Learning (C3L) of the University of Oldenburg. The development of AWE is tightly integrated into the project and quality management of the mint.online project lead by C3L. ForWind took part in the following meetings of the project mint.online: webinar Gender (February 2014), mint.online project meeting in Berlin (March 2014), webinar about concepts of mentoring (Mai 2014), mint.online project meeting (September 2014).

## Project Management

Corporate principles for the Certificate Advanced Wind Energy have been fixed in a document as foundation for future activities. ForWind took part in the following meetings of the project mint.online:

- Webinar Gender (February `14)

- Central mint.online project meeting in Berlin (March `14)
- Webinar about concepts of mentoring (May `14)
- Central mint.online project meeting (September `14)

## Summary

ForWind is developing the "Certificate Programme in Advanced Wind Energy (AWE)" within the "mint.online" project funded by the Federal Ministry of Education and Research (BMBWF). AWE will be an academic continuing studies programme for scientists and engineers. A first test run of the module "CFD 1" has been executed in the summer semester of 2014. The second project phase will start in April 2015 and end in September 2017.

Link:  
<https://www.uni-oldenburg.de/en/physics/studies/courseofstudies/ppres/master-online-renewable-energy/partner-programmes/certificate-programme-advanced-wind-energy/>

# ForWind-Academy

Carl von Ossietzky Universität Oldenburg,  
ForWind

Stephan Barth, Katharina Segelken,  
Moses Kärn, Christoph Schwarzer

Partner: Dr. Hans-Peter (Igor) Waldl  
(Overspeed GmbH & Co. KG),  
Bernd Hömberg (Haus der Technik e. V.,  
Essen)

## Introduction

ForWind-Academy's aim is to support the onshore and offshore wind energy industry by knowledge transfer from research to application and to spread the know-how within the industries. Onshore and offshore wind energy are both highly competitive and innovative industry sectors. ForWind-Academy launched in 2008 stands for high level continuing education for wind energy specialists and executives in Germany.

## Project Description

ForWind-Academy provides comprehensive qualification on academic level for the wind energy sector by seminars, in-house courses, workshops and individual coaching. ForWind-Academy is a joint project of ForWind and Overspeed GmbH & Co. KG. This co-operation opens up a great possibility to provide high-quality seminars and advanced education on topics ranging from research to application in the industry. The wide network of ForWind makes it possible to provide expert speakers from inside and outside the university. Dr. Hans-Peter (Igor) Waldl himself, managing director of Overspeed GmbH & Co. KG, possesses an expertise as a consultant and course instructor with 20 years of wind energy experience. The seminar program comprises wind energy topics of planning, management, financ-

ing as well as technology. Seminars on offer take up current issues occurring in the real-world and present interfaces to scientific knowledge gained from research and development. The Academy is particularly adept when it comes to a high level of expertise and the didactic preparation of seminar topics and content. ForWind-Academy is not merely offering introductory knowledge in a rush. Seminars convey fundamental knowledge, give insight into research questions, and offer practice oriented know-how.

The ForWind-Academy offers a platform for intensive advanced education and the exchange of ideas among experts in the field. It brings together people with different occupations, experience, and careers. Target groups are young professionals as well as experts and decision makers in the wind energy sector. Also, those who wish to enter this field find seminars that suit their needs for an introduction into wind energy.

In 2013, a total of 19 one-, two- and three-day seminars were offered with round about 200 participants. Compared to 2012, three completely newly developed seminars have been offered in 2013 covering the following topics: "Corrosion and anticorrosive coating for offshore wind constructions", a workshop with the topic "Calculation of profitability" and a special seminar with the topic "Health and safety for offshore wind energy workers". In 2014 a total of 16 seminars were offered with around 120 participants were offered, e. g. "Operation and maintenance of offshore wind farms". A lot of practical elements like field trips and group work have been added to most of our seminars to make them more interactive. Participants highlighted these new elements in our seminar evaluations as very positive. In 2013 and 2014 the co-operation with Haus der Technik e.V. (HdT), Essen, has been extended and consolidated. But, ForWind-Academy and HdT – like all seminar providers in wind energy – are facing

a decline in numbers of participants. This is most likely due to the fact that the wind energy sector, like all renewable energy sectors, is highly sensitive to political debates about the and economic framework, and the years 2013 and 2014 were years of very intense debates about the cost of the "Energiewende". ForWind-Academy is doing active networking and marketing for continuing education in wind energy, building on the alumni network of the academy and the "Windstudium". Representatives of the ForWind-Academy were also present at the following events: the jobfair "zukunftsenergien nordwest" in March 2013 and 2014, the Hanover fair in April 2014, the WindEnergy 2014 in Hamburg. ForWind-Academy has joined the "Windenergiertage 2013" in Rheinsberg and "Windenergiertage 2014" in Potsdam. This conference in the Berlin/Brandenburg area has been visited by round about 1000 participants. Christoph Schwarzer and Katharina Segelken were in charge of the session "Wissen ist Macht" (knowledge is power).

## Summary

ForWind-Academy offers continuing education for wind energy specialists and executives in Germany. Together with Overspeed GmbH & Co. KG., has established its reputation as one of the leading providers for high-level seminars dealing with current topics on an academic level and with a high degree of relevance to practical applications: ranging from planning, management, financing to science and technology. In 2015, ForWind-Academy will continue the co-operation with Haus der Technik e.V. in Essen, Germany, and will aim at a further adaption of seminars according to current developments of the wind energy branch.

Link:  
[www.forwind-academy.com](http://www.forwind-academy.com)



# Job and Education Fair "zukunftsenergien nordwest" 2014

Carl von Ossietzky Universität Oldenburg,  
ForWind

Corinna Wermke, Christoph Schwarzer

#### Partners:

WAB e.V., Oldenburger Energiecluster (OLEC) e.V., Bremerhavener Gesellschaft für Investitionsförderung und Stadtentwicklung mbH (BIS), Wirtschaftsförderung Bremen GmbH, Wirtschaftsförderung Stadt Oldenburg, Hochschule Bremerhaven

#### Sponsored by:

Bremer Landesbank, Enercon GmbH

## Introduction

The renewable energies are an important economic factor in Germany and especially in the northwest region. Their potential for growth is high, and they offer an important perspective for future employment. With more than 370.000 employees nationwide the renewable energies are a job-motor already. Experts predict a further development of more than 500.000 jobs until 2030. But at the same time, the renewable energies sector, like many others, suffers from a lack of specialists. And there still are not enough adequately specialized training and further education programs. The renewable energies are a relatively new occupational area and always in competition to other well established career paths in traditional industries. Therefore the job and education fair in the Northwest, the "zukunftsenergien nordwest", is still an important event for the region demonstrating its rich job and qualification opportunities in renewable energies.

## Project Description

The job and education fair for renewable energies and energy efficiency, the "zukunftsenergien nordwest", opened its gates for the fourth time on the 1st and 2nd March 2013 in Bremen and for the fifth time on the 21st and 22nd March 2014 in Oldenburg. 79 exhibitors in 2013 and 68 exhibitors in 2014 were presenting themselves on the job fair: companies, universities, institutes for further training and research institutes involved in renewable energies and energy efficiency. 4.500 visitors in 2013 and 3.000 in 2014 met attractive employers with open job opportunities and traineeships. They informed themselves on prospects for further education, and received insight into

the branch by taking part in workshops and company presentations. The "zukunftsenergien nordwest" offered exhibitors a high-profile public platform where companies and service providers meet together with an audience interested in their sector along with potential young applicants and those looking to enter from other fields of expertise. This program was complemented by excursions to well known companies and regional facilities as well as application trainings.

The "zukunftsenergien nordwest" is supposed to take place once a year alternating in Oldenburg and Bremen. It started 2010 in Oldenburg.



Job and Education Fair "zukunftsenergien nordwest 2014"

**zukunftsenergien**  
**nordwest** JOB- & BILDUNGSMESSE

# ForWind-Events 2013

## ForWind Course of Lectures

ForWind Head Office

Elke Seidel

After a pause ForWind restarted the public course of lectures "ForWind Vortragsreihe" concerning various, predominantly technical aspects of energy research and supply, focussing on wind energy, serving as a connecting link among research institutions, universities and the industry, inviting national and international speakers and discussing their area of expertise.

Winter Term 2013/2014

**Neues Konzept für ein Offshore-Umspannwerk – schwimmend transportiert, umweltverträglich installiert und immer bewohnt**  
 Dr. Claus Burkhardt,  
 Geschäftsführer Technik Betrieb, Global Tech I Offshore Wind GmbH

**Riffgat – Errichtung eines Offshore-Windparks in der Nordsee**  
 Irina Lucke,  
 Geschäftsführerin, EWE Offshore Service & Solutions GmbH

**HGÜ-Erdkabel: Potentiale und Erfahrungen on- und offshore**  
 Heike Klaus,  
 Projektleiterin Genehmigungen Near- und Onshore Offshore Kaufmännische Aufgaben und Initiierung | Projektinitiierung, TenneT Offshore GmbH

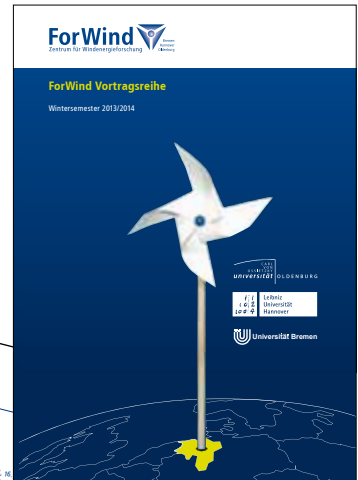

**DyNaLab – der großtechnische Prüfstand für komplette Gondeln von Windenergieanlagen**  
 Prof. Dr.-Ing. Jan Wenske,  
 stellvertretender Institutsleiter Fraunhofer-Institut für Windenergie und Energiesystemtechnik IWES Bremerhaven

**Bauwerk Offshore Windenergieanlage – wie baut man das aus Beton?**  
 Prof. Dr.-Ing. Steffen Marx, Geschäftsführender Leiter des Instituts für Massivbau, Leibniz Universität Hannover

**Smart Nord – Intelligente Netze Norddeutschland**  
 Prof. Dr. Michael Sonnenschein,  
 Sprecher des Forschungsverbundes und Leiter der Abteilung Umwelthinformatik, Carl von Ossietzky Universität Oldenburg

**Challenges for a base and service port in the offshore wind industry – the Port of Esbjerg**  
 Søren Clemmensen,  
 Sales Manager Port of Esbjerg





Dr. Claus Burkhardt,  
Global Tech I Offshore Wind GmbH



Prof. Dr.-Ing. Jan Wenske,  
Fraunhofer-Institut für Windenergie und Energiesystemtechnik  
IWES



Irina Lucke,  
EWE Offshore Service & Solutions GmbH



Prof. Dr.-Ing. Steffen Marx,  
Leibniz Universität Hannover



Heike Klaus,  
TenneT Offshore GmbH



Prof. Dr. Michael Sonnenschein,  
Carl von Ossietzky Universität Oldenburg

## Hannover Messe 2013, April 8th - 12th

ForWind Head Office

Elke Seidel

Also in April 2013 ForWind participated again in the Hannover Messe – the world's biggest industrial fair – at the joint stand of Lower Saxony “Energie aus Niedersachsen“, introducing ForWind and its services in research, consultancy, education, further education and events.

For the first time, ForWind presented the newly developed compact wind LiDAR „Whirlwind“ for integration in wind turbines supporting the control system by direct inflow measurements and thus reducing loads induced by wind gusts.

ForWind also presented two additional measurement methods:

Multi-LiDAR and the enhanced 2D-Laser-Cantilever-Anemometer.

Multi-LiDAR is a measurement facility which is under development at ForWind based on LIDAR – Light Detection And Ranging.

Multi-LiDAR allows for velocity measurements in complex atmospheric flows in three dimensions with a high temporal and spatial resolution.

The further enhanced 2D-Laser-Cantilever-Anemometer for high-precision measurements of wind speeds and directions is

a method for laboratory wind flows, which could be used and tested by visitors on the spot.

In the field of further education ForWind presented its two study programs „Continuing Studies Program Wind Energy Technology and Management“ and „Continuing Studies Program Offshore Wind Energy“ as well as the seminar program of the ForWind Academy, a partner for qualification in the wind energy sector.

Within organized tours of the initiative "Tectoyou" several pupils choose to inform themselves about wind energy at ForWind. Using exhibits, it was inter alia explained why wind power turbines have to cut out during a storm.

ForWind was glad to welcome two of Lower Saxony's Ministers as well as representatives of the EU amongst many other visitors.

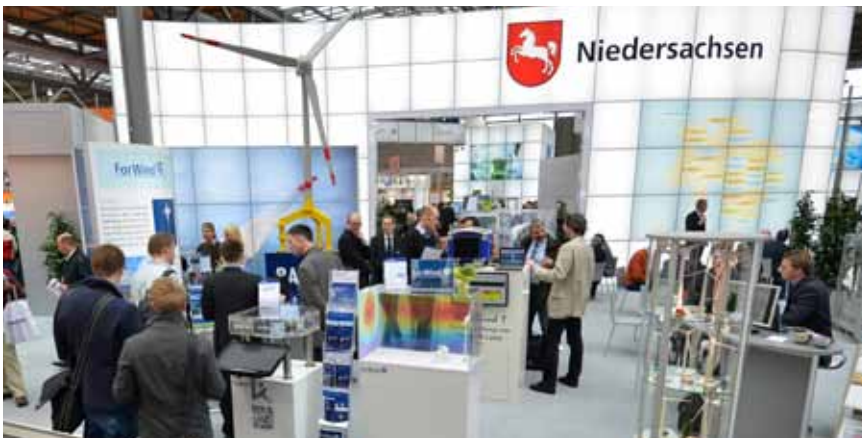

EU-Commissioner for Research, Innovation and Science Máire Geoghegan Quinn



EU delegate Matthias Groote



Almut Kottwitz, State secretary of the Ministry for Environment, Energy and Climate Protection



The Minister of Science and Culture Dr. Gabriele Heinen-Kljajić



Dietmar Schütz, President of the German Renewable Energy Federation BEE (Bundesverband Erneuerbare Energie e.V.)



The new compact wind LiDAR



The Minister for Economics, Labour and Transport Olaf Lies



International Delegations



Trade visitors



Visits of pupils organized by Tectoyou



Knowledge transfer by exhibits



Industry experts

# German Unity Day Tag der Deutschen Einheit 2013 in Stuttgart

ForWind Head Office

Elke Seidel



ForWind was asked to give an insight into wind energy and wind energy research in the pavilion of Lower Saxony during the festivities around the German Unity Day 2013 in Stuttgart October 2nd – 3rd, starting already with a welcome opening party on the evening of October 1st.

To demonstrate how huge wind turbines have become, ForWind exhibited an original offshore wire cross section and an original screw and winding combination

used in the tower which could be touched and hold.

In addition the laser measurement technique LiDAR (light detection and ranging) was shown as well as an activity exhibit to create a storm deactivation of a wind turbine model.

The main attraction and a great success was a photo session offered by ForWind with a wind turbine model and a group of

true-to-life sheep. Visitors could take their photograph home as a postcard with an invitation to visit Hannover on the German Unity Day 2014.

Several thousand people visited the festivities and ForWind distributed more than 850 photographs to all kinds of visitors, young and old – between them the Prime Minister of Lower Saxony Stefan Weil and the Minister of Justice and Antje Niewisch-Lennartz.





# Research Alliance for Wind Energy Signing of the Cooperation Agreement

ForWind Head Office

Elke Seidel, Stephan Barth

Partners:

German Aerospace Centre (DLR),  
Fraunhofer Institute for Wind Energy and  
Energy Systems Technology (IWES)

A unique alliance for German wind energy research was officially formed in Berlin on January 31st – the Research Alliance for Wind Energy.

Representatives of the three partners, the German Aerospace Centre (DLR), ForWind, the Center for Wind Energy Research of the Universities Oldenburg, Hannover and Bremen, and the Fraunhofer Insti-

tute for Wind Energy and Energy Systems Technology (IWES) signed the cooperation agreement. The combined know-how of more than 600 scientists will pave the way for ground-breaking impulses for a renewable energy future based on on- and offshore wind energy.

The research alliance, through its personnel strength and by networking knowledge and expertise, will be able to successfully process long term and strategically important major projects.

A research infrastructure with test centres and laboratories will process innovative issues and set standards across the globe.

The partners' content-related cooperation starts directly in the BMU funded project "Smart Blades – Development and Con-

struction of Intelligent Rotor Blades" which has a project volume of 12 million Euros and a runtime of 39 months.

Turbine builders so far have shied away from the development and use of smart blades. The great challenge will be that through use of active mechanisms the rotor blades do not become less reliable, heavier and more maintenance intensive and prime costs do not increase. Therefore, the target of the research project is proving the feasibility, efficiency and reliability of smart blades.

The kick-off for this first major alliance project was also on January 31st in Berlin, meaning that work, using one „passive“ and two alternative „active“ technologies, on the rotor blade design tasks could go ahead immediately.





# Research Alliance for Wind Energy First Research Colloquium on October 8th in Bremen

ForWind Head Office

ForWind Oldenburg:  
Elke Seidel, Stephan Barth  
ForWind Bremen:  
Birgit Erdfelder, Klaus-Dieter Thoben, BIBA

Partners:  
German Aerospace Centre (DLR),  
Fraunhofer Institute for Wind Energy and  
Energy Systems Technology (IWES)

Following the official signment of the coop-  
eration agreement in January, the Research  
Alliance for Wind Energy decided to organ-  
ize an annually meeting to get to know the  
institutions' colleagues, exchange results

and ideas and discuss further needs for wind  
energy research as well as the future strat-  
egy for the research alliance.

The first research colloquium took place  
in Bremen at the BIBA, a scientific engi-  
neering research institute. In general talks  
and discussions the main research topics  
were identified by voting and lively talked

through in smaller groups. The results  
again being presented afterwards in full as-  
sembly.

The first meeting was a success, and will  
be followed by a meeting in 2014 in Braun-  
schweig. Since February 2013 the research  
alliance has got its own logo.



## Research Alliance Wind Energy



## Research Alliance for Wind Energy Meeting with Federal Minister for the Environment, Nature Conservation, Building and Nuclear Safety Peter Altmaier

ForWind Head Office

Elke Seidel

Partners:

German Aerospace Centre (DLR),  
Fraunhofer Institute for Wind Energy and  
Energy Systems Technology (IWES)

On January 17th the coordinators of the Research Alliance for Wind Energy had the possibility to meet the German Federal Minister for the Environment, Nature Conservation, Building and Nuclear Safety (BMU) Peter Altmaier in Berlin.

Dr. Jan Teßmer, German Aerospace Center (DLR), Dr. Stephan Barth, ForWind – Center for Wind Energy Research and Prof. Dr.

Andreas Reuter, Fraunhofer Institute for Wind Energy and Energy System Technology IWES presented the Research Alliance and discussed the need of sustaining political framework for wind energy research. Part of the talk was the BMU funded project “Smart Blades – Development and Construction of Intelligent Rotor Blades”, the first joint research programme of the research alliance.



## European Academy of Wind Energy – Head Office in Oldenburg

The EAWE e.V. is a registered body of research institutes and universities in Europe working on wind energy research and development. The Academy was founded in 2004 to formulate and execute joint R&D projects and to coordinate high quality scientific research and education on wind energy at a European level.\*

At the end of 2013 the Ministry of Science and Culture of Lower Saxony granted financial support for the EAWE to establish a head office in Oldenburg to support the annually elected President, Vice President and Past President.

\*Source: [www.eawe.eu](http://www.eawe.eu)



European Academy of Wind Energy

## Selection of International Events and Visits

### Dutch Wind Energy Professor Gijs van Kuik for research visit in Germany

In cooperation with ForWind Oldenburg Professor Dr. Gijs van Kuik, stayed as a „Fellow“ for a three months fellowship at the Hanse-Wissenschaftskolleg (HWK) in Delmenhorst from April to June 2013. Van Kuik is professor at the Delft University of Technology and inter alia scientific

director of the wind energy research organization DUWIND and longtime member of EAWE, of which he was president in 2008/2009. Free of academic obligations van Kuik could spend time at the University of Oldenburg on chosen scientific projects.



### EAWE-Seminar „Long-term Scientific Challenges in Wind Energy Development“

In the midst of May 2013 the first EAWE seminar „Long-term Scientific Challenges in Wind Energy Development“ took place, organized by Prof. Dr. Joachim Peinke (Universität Oldenburg), Prof. Dr. Gijs van Kuik (University of Delft) und Carlos Simão Ferreira (University of Delft) in cooperation with the Hanse-Wissenschafts-

kolleg (HWK) in Delmenhorst. Intention was a working paper of the needed future direction of wind energy research which being mutually developed online by the EAWE members afterwards should be used to also include basic research in future research programmes.



### Newspaper Readers won ForWind Visit in Competition

An exclusive insight in ForWind's laboratories and wind tunnel in Oldenburg was the prize for a group of newspaper readers in July who took successfully part in a competition. Within two hours a LiDAR (light detection and ranging) measurement facility on the university's roof was visited

as well as the wind tunnel on the ground floor with possible speed rates up to 50 m/s. Inter alia also a smaller wind tunnel with an active mesh was shown, used to create turbulent flows and needed for the more an more important turbulent research.



# ForWind-Events 2014

## ForWind Course of Lectures

ForWind Head Office

Elke Seidel

After a pause ForWind again started its public course of lectures concerning various, predominantly technical aspects of energy research and supply, focussing on wind energy, serving as a connecting link among research institutions, universities and the industry, inviting national and international speakers and discussing their area of expertise.

Summer Term 2014

### Niedersachsen macht Kohle – CO2-neutrale Kohle aus biogenen Rest- und Abfallstoffen

Thomas Greve, Institut für Physik, Universität Oldenburg

### Testzentrum für Tragstrukturen – ein Beitrag zur Optimierung von Onshore- und Offshore-Windenergieanlagen

Dr.-Ing. Maik Wefer, Abteilungsleiter Tragstrukturen, Fraunhofer-Institut für Windenergie und Energiesystemtechnik IWES | Hannover



**ForWind**  
Zentrum für Windenergieforschung

**ForWind Vortragsreihe**  
Sommersemester 2014

Ammerländer Heerstr. 136  
26129 Oldenburg  
Gebäude V02, Seminarraum 114, 1. Stock

---

**Donnerstag, 08.05.2014, 16:15 Uhr**  
**Niedersachsen macht Kohle**  
**CO<sub>2</sub>-neutrale Kohle aus biogenen Rest- und Abfallstoffen**  
Thomas Greve, Institut für Physik, Universität Oldenburg

Kohle gilt zu Recht als „dreckiger“ Energieträger. Der Begriff „Biotonne“ wirkt daher wie ein Widerspruch in sich. Tatsächlich verbirgt sich hinter dem Verfahren der Hydrotrennung Celluloseerzeug (WCE) ein Forschungsfeld, das stark durch Nachhaltigkeit geprägt ist: Nutzung von Rest- und Abfallstoffen, Kreislaufwirtschaft, CO<sub>2</sub>-neutrale Energie und sogar die Möglichkeit, der Atmosphäre CO<sub>2</sub> zu entziehen und in Böden einzulagern. In diesem Vortrag wird das Thema Bioenergie anhand des in Niedersachsen aktuell laufenden EU-Forschungsprojekts zur WCE im Gesamtzusammenhang vorgestellt.

---

**Donnerstag, 12.06.2014, 16:15 Uhr**  
**Testzentrum für Tragstrukturen – ein Beitrag zur Optimierung von Onshore- und Offshore-Windenergieanlagen**  
Dr.-Ing. Maik Wefer, Abteilungsleiter Tragstrukturen, Fraunhofer-Institut für Windenergie und Energiesystemtechnik IWES | Hannover

Die größten Ausbaupotenziale regenerativer Energieformen liegen in On- und Offshore-Windenergie. Hier ergeben sich insbesondere für Tragstrukturen neue Herausforderungen und Forschungsbedarf: Offshore steigen bei großen Wassertiefen die Investitionskosten für Tragstruktur und Gründung der Anlagen stark an und müssen werden immer höhere Türme angestrebt. Die Entwicklung neuer Konzepte ergibt erhebliches ökonomisches und ökologisches Einsparpotenzial bei On- und Offshore-Windenergieanlagen. An der Universität Hannover entsteht daher in Kooperation mit dem Fraunhofer-Institut für Windenergie und Energiesystemtechnik IWES das Testzentrum für Tragstrukturen.

---

**Donnerstag, 10.7.2014, 16:15 Uhr**  
**Wie wird das Wetter morgen?**  
**Innovative Wetter- und Leistungsprognosemodelle für die Netzintegration wetterabhängiger Energieträger – das Forschungsprojekt EWEliNE**  
Dr. Malte Siefert, Projektleiter des Forschungsprojekts EWEliNE, Fraunhofer-Institut für Windenergie und Energiesystemtechnik IWES | Kassel

Um ein Stromversorgungssystem mit sehr großen Anteilen wetterabhängiger Erzeuger sicher betreiben zu können, muss man den primären Antrieb – das Wetter – nicht nur global sondern auch regional sehr detailliert kennen und vor allem vorhersagen können. Das Wetter hat somit einen direkten Einfluss auf die Steuerung von fossilen Kraftwerken und den Netzbetrieb. Neben der Entwicklung und Etablierung neuartiger Prognosewerkzeuge spielt die Integration energiewirtschaftlicher Informationen (wie beispielsweise aktueller Windleistungsdaten) in die Berechnungen der Wettermodelle eine besondere Rolle.

---

**Donnerstag, 17.07.2014, 16:15 Uhr**  
**Offshore-Windparks in Nord- und Ostsee – Was ist im Genehmigungsverfahren zu beachten?**  
Dr. Nico Nolte, Leiter des Referates „Ordnung des Meeres“ am Bundesamt für Seeschifffahrt und Hydrographie (BSH)

Bis 2020 sollen Offshore-Windparks mit einer Leistung von 6,5 Gigawatt ins elektrische Netz eingespeist. Dr. Nico Nolte gibt einen Überblick über sicher realisierte Offshore-Windparks, geplante Bauvorhaben und deren technische Herausforderungen sowie die Anforderungen für sicheren und zuverlässigen Betrieb. Das BSH bearbeitet und genehmigt die Beanträge innerhalb der deutschen ausschließlichen Wirtschaftszone und prüft unter anderem, ob Beeinträchtigungen für die Sicherheit und Leichtigkeit des Verkehrs, die Sicherheit der Bundesverteidigung oder Gefährdungen für die Meeresumwelt und den Vogeltzug vorliegen.

---

**Donnerstag, 24.07.2014, 16:15 Uhr**  
**Holz – der neue Baustoff für Windenergieanlagen der Multimegawattklasse?**  
Christian Kreyenschmidt, Produktentwickler und Bauleiter, TimberTower GmbH

Die TimberTower GmbH entwickelt Windenergieanlagen, bei denen der nachwachsende Rohstoff Holz als Baustoffalternative zu Stahl und Beton für Türme und Fundamente eingesetzt wird. Eine 1,5 Megawatt-Anlage mit einem Holzturm und einer Bauwerkshöhe von 138,5m wurde in Hannover-Mariemünde realisiert und sendet bereits Strom für 1.000 Haushalte um. Der Bau eines Holzturmes für eine 2,5 Megawatt-Anlage mit einer Nabenhöhe von 140m ist für 2014 geplant. Der Vortrag erklärt, wo und warum Holz-basierte Materialien in Bezug auf Belastbarkeit, Langlebigkeit und Verlässlichkeit ersetzen kann.

Weitere Informationen zu den Veranstaltungen finden Sie unter www.forwind.de/vortragsreihe  
Die Veranstaltungen finden im kostenlosen offenen Hörsaalgebäude statt und sind für alle Interessierten offen. Die Veranstaltung ist kostenlos und kann online in der Webinarreihe unter [www.forwind.de](http://www.forwind.de) verfolgt werden.

### Wie wird das Wetter morgen? Innovative Wetter- und Leistungsprognosemodelle für die Netzintegration wetterabhängiger Energieträger – das Forschungsprojekt EWEliNE

Dr. Malte Siefert, Projektleiter des Forschungsprojekts EWEliNE, Fraunhofer-Institut für Windenergie und Energiesystemtechnik IWES | Kassel

### Offshore-Windparks in Nord- und Ostsee – Was ist im Genehmigungsverfahren zu beachten?

Dr. Nico Nolte, Leiter des Referates „Ordnung des Meeres“ am Bundesamt für Seeschifffahrt und Hydrographie (BSH)

### Holz – der neue Baustoff für Windenergieanlagen der Multimegawattklasse?

Christian Kreyenschmidt, Produktentwickler und Bauleiter, TimberTower GmbH





Thomas Greve, Institute of Physics, Universität Oldenburg



Dr.-Ing. Maik Wefer, Head of department Support Structures, Fraunhofer Institute for Wind Energy Systems IWES | Hanover



Dr. Malte Siefert, project manager of the research project EWeLiNE, Fraunhofer Institute for Wind Energy Systems IWES | Kassel



Dr. Nico Nolte, head of the unit „Ordnung des Meeres“ at the Federal Maritime and Hydrographic Agency of Germany (BSH)



Christian Kreyenschmidt, product designer and construction manager, TimberTower GmbH



## Hannover Messe 2014, April 7th - 11th

ForWind Head Office

Elke Seidel

At the Hannover Messe in April 2014, the world's biggest industrial fair, ForWind was again amongst the presenting partners at the joint stand of Lower Saxony "Energie aus Niedersachsen".

Introducing ForWind and its services in research, consultancy, education, further education and events, ForWind also focussed on exhibiting measurement techniques:

The compact wind LiDAR "Whirlwind", developed at the University of Oldenburg for integration in wind turbines supports the control system by direct inflow meas-

urements, thus reducing loads induced by wind gusts.

Multi-LiDAR a measurement facility under development at ForWind (based on LIDAR – Light Detection And Ranging) allows for velocity measurements in complex atmospheric flows in three dimensions with a high temporal and spatial resolution.

With the new sphere anemometer, ForWind Oldenburg features a sensor prototype which provides a high temporal and spatial resolution. The absence of moving parts makes it a durable and low-maintenance sensor for offshore use. In the field of education ForWind informed about several study courses and course specialisations in Wind Energy, the further education study programmes "Continuing Stud-

ies Programme Wind Energy Technology and Management" and "Continuing Studies Programme Offshore Wind Energy" as well as the seminar programme of the ForWind Academy, a partner for qualification in the wind energy sector. Next to trade visitors from public service, research and industry, international delegations and students also several groups of interested pupils within the organized tours of the initiative "Tectoyou" were welcomed.

ForWind was especially glad to meet the Prime Minister of Lower Saxony Stefan Weil, the Federal Minister of Education and Research Prof. Dr. Johanna Wanka, the Minister for Economics, Labour and Transport Olaf Lies and the Minister for Environment, Energy and Climate Protection Stefan Wenzel.



The new compact wind LiDAR

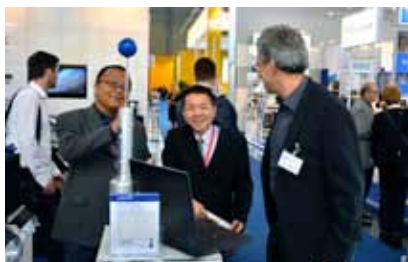

Trade Visitors

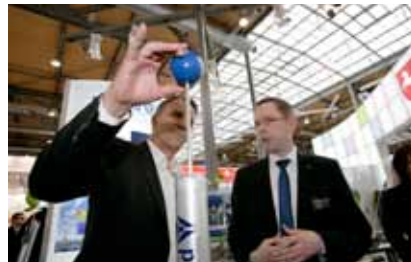

The Minister for Environment, Energy and Climate Protection Stefan Wenzel



Meeting experts from Ministry and Industry



The Federal Minister of Education and Research Prof. Dr. Johanna Wanka



Public talk within the forum of the German Renewable Energy Federation BEE (Bundesverband Erneuerbare Energie e.V.)



Visit of ForWind's Scientific Advisory Council



The Prime Minister of Lower Saxony Stefan Weil



International Delegations



Informational talk



The Minister for Economics, Labour and Transport Olaf Lies



Organized tours for pupils by the initiative "Tectoyou"



International groups of students

## Tenth Anniversary of ForWind

### ForWind Head Office

Combining research on wind energy and promoting the transfer of knowledge between science, industry and politics – this is the goal of ForWind, the Center for Wind Energy Research, which was launched in 2004. Nine research groups from the universities of Oldenburg and Hanover joined forces. The University of Bremen joined the Centre in 2009. Today ForWind has 28 working groups at its three locations with almost 300 employees. They conduct engineering and physical research in all areas of wind energy.

ForWind celebrates its tenth anniversary with a ceremony in the lecture hall centre of the University of Oldenburg

On February 18th ForWind celebrated its tenth anniversary with a ceremony in the lecture hall center of the University of Oldenburg and looked back on a dynamic development. Guests included the Minister of Science and Culture of Lower Saxony, Dr. Gabriele Heinen-Kljajic, Prof. Dr. Katharina Al-Shamery, Vice President for Research at Oldenburg University, Prof. Dr.-Ing. Erich Barke, President of Leibniz University Hannover and Dr. Martin Mehrrens, Chancellor of Bremen University, as representatives of the participating universities and numerous personalities from politics, business and science.

"The ForWind research alliance provides important impulses for the future of renewable energies," said Dr. Gabriele Heinen-Kljajic, Lower Saxony's Minister of Science and Culture, on the occasion of the institution's tenth anniversary. "With its strong international engagement and close cooperation with partners from science and industry, ForWind has contributed to making the Northwest a leading location for wind energy research."





# Research Alliance for Wind Energy is awarded the "Norddeutsche Wissenschaftspreis 2014"

ForWind Head Office  
Stefan Barth, Elke Seidel

The Research Alliance for Wind Energy of the three partners, the German Aerospace Centre (DLR), ForWind, the Center for Wind Energy Research of the Universities Oldenburg, Hannover and Bremen, and the Fraunhofer Institute for Wind Energy and Energy Systems Technology (IWES) won the "Norddeutsche Wissenschaftspreis 2014".

The northern federal states of Germany (Bremen, Hamburg, Mecklenburg-West Pomerania, Lower Saxony and Schleswig-Holstein) aim to further strengthen research within their states and improve research networking between them.

Therefore since 2012 they are offering a mutual open competition for northern cross-national project cooperation in the field of science.

The goal is to not only support cross-national cooperation within the northern federal states but also to increase its visibility.

Each year the ceremony is organised by a different federal state with a varying focus. In 2014 the focus was energy research and the ceremony took place in Hannover, Lower Saxony. The award is endowed with prize money of 50.000,00 Euros.



Norddeutscher Wissenschaftspreis 2014 – awarded by the Minister of Science and Culture of Lower Saxony Dr. Gabriele Heinen-Kljajić  
Foto: Daniel Pilar/Nds. Ministerium Wissenschaft und Kultur



Norddeutscher Wissenschaftspreis 2014 – representatives of the ministries and senators of the northern federal states, of the award winners  
Foto: Daniel Pilar/Nds. Ministerium Wissenschaft und Kultur

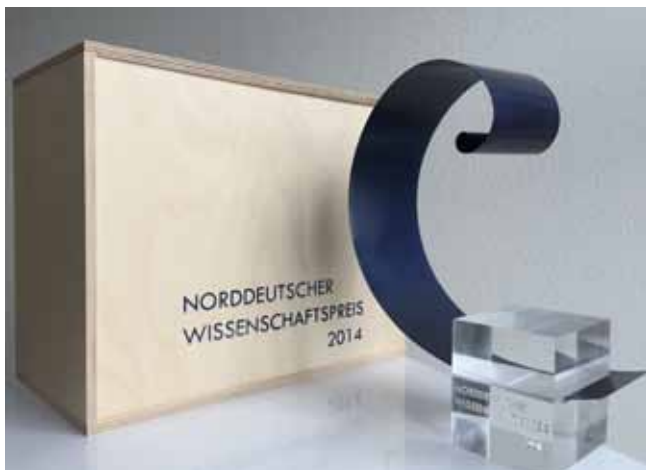

Norddeutscher Wissenschaftspreis 2014 – The Award



## Testing Towers and Foundations – Opening of the Wind Energy Test Centre for Support Structures (Testzentrum für Tragstrukturen, TTH) in Hannover-Marienwerder in September 2014

Leibniz Universität Hannover  
Forwind

Raimund Rolfes, Peter Schaumann

One of the most spectacular new construction projects of the Leibniz Universität Hannover was opened in September 2014 after almost two years of construction. The new Test Centre for Support Structures is located in Hannover-Marienwerder. It will perform high-level strategic research in the area of onshore and offshore wind turbines, for instance optimization of the design of support structures and construction technology. For the ceremonious opening,

high-ranking representatives from politics and the economy were greeted: Stephan Weil, Prime Minister of Lower Saxony, and Uwe Beckmeyer, Parliamentary State Secretary in the Federal Ministry for Economic Affairs and Energy.

For a successful energy turnaround technological innovations are needed. The new Test Centre for Support Structures (TTH) can make a substantial contribution in order to meet this objective and to step up the wind energy research in Lower Saxony. The business location Germany benefits immensely from the excellent transfer of practical experience. Hence, the Federal Ministry for Economic Affairs and Energy

decided to finance the Test Center by allocating 17.8 million Euro.

Fraunhofer Institute for Wind Energy and Energy System Technology (IWES) and the Leibniz Universität Hannover have signed a cooperation agreement through joint activities in the area of wind energy research. The construction of the Test Centre is part of the cooperation agreement. The Test Center facilitates realistic testing and shortens the time to market readiness of the design of support structures.

For the ceremonious opening, high-ranking representatives from politics and the economy were greeted: Stephan Weil,



Test Centre for Support Structures (TTH) in Hannover-Marienwerder, picture: Mathias Schumacher, Leibniz Universität Hannover

Prime Minister of Lower Saxony, and Uwe Beckmeyer, Parliamentary State Secretary in the Federal Ministry for Economic Affairs and Energy.

For a successful energy turnaround technological innovations are needed. The new Test Centre for Support Structures (TTH) can make a substantial contribution in order to meet this objective and to step up the wind energy research in Lower Saxony. The business location Germany benefits immensely from the excellent transfer of practical experience. Hence, the Federal Ministry for Economic Affairs and Energy decided to finance the Test Center by allocating 17.8 million Euro.

Fraunhofer Institute for Wind Energy and Energy System Technology (IWES) and the Leibniz Universität Hannover have

signed a cooperation agreement through joint activities in the area of wind energy research. The construction of the Test Centre is part of the cooperation agreement. The Test Center facilitates realistic testing and shortens the time to market readiness of the design of support structures.

Together with scientists from the Fraunhofer Institute for Wind Energy and Energy System Technology (IWES) and various LUH institutes, private and public sector clients have the opportunity to develop robust support structures.

The Test Center for Support Structures (TTH) for onshore and offshore wind turbines offers a unique infrastructure for testing all types of support structures (towers and foundations) on a scale of 1:10 and larger.

The foundation test pit and the span can be used to investigate fatigue and extreme load behavior under multi-axial loading. The test center also offers four specially equipped laboratories to carry out scientific investigations. The “Structural Health Monitoring laboratory”, the “soil mechanics laboratory”, the “concrete laboratory” and the “fiber composite laboratory” complete the infrastructure of the test center.

Clearly defined testing procedures up to extreme loads provide reproducible results and thus allow complex questions to be answered. Bringing together structural models, numerical analyses and large-scale experiments, simulation models can be validated, and wind turbines with improved availability and better cost effectiveness can be realized.



Ceremonious opening of the Test Center by Prof. Dr.-Ing. Raimund Rolfes, Prime Minister of Lower Saxony Stefan Weil, Parliamentary State Secretary in the Federal Ministry for Economic Affairs and Energy Uwe Beckmeyer, President of the Leibniz Universität Hannover Prof. Dr. Ing. Erich Barke, Prof. Dr.-Ing. Thorsten Schlurmann and Prof. Dr.-Ing. Peter Schaumann (from left to right), picture: Mathias Schumacher, Leibniz Universität Hannover



Foundation test pit of the Test Center, picture: Mathias Schumacher, Leibniz Universität Hannover

The structure's dynamic and fatigue behavior under long-term cyclic loading by waves, wind and operation can be reproduced in short time, i.e., tests lasting three to four months can provide meaningful results.

System reserves can be determined, further optimization potential can be defined, and the structural design can be adapted accordingly. Constructing more slender structures while maintaining structural safety and reliability enables savings on materials and logistics. Besides, more environmentally acceptable and economical construction methods can be developed and tested at TTH.

Adapted to the requirements of wind power plants, the Generator Converter Laboratory (GeCoLab) with a test bench for generators and converters will be available. The

generator converter test bench consists of a test bench (IMW) with the most common generator types (permanent-magnet synchronous machine and double-fed asynchronous machine). Both are connected by gear. A 3 MW net emulator can simulate all important grid situations. The focus of research lies on interactions of generator and converter, grid supporting strategies for wind turbines (converter control) and aspects of generators (early fault recognition, fault-tolerant operation, bearing current).

The Test Center for Support Structures is property of Leibniz Universität Hannover and ForWind. Fraunhofer IWES is the main user of the infrastructure.

The facilities at the centre are rounded off with special laboratories for concrete, fibre composite materials and geotechnical investigations along with a resonance testing

machine and a climate chamber. This results in reproducible data for extreme and cyclic loading of components and materials. Three to four months are required in the hall to simulate the requirements during a wind turbine's entire lifespan. The interplay of models, large-scale experiments and numerical calculations make it possible to design wind turbines more precisely and to validate simulation programmes.



Experimental setup with span, electrical machinery and connector panel, picture: Institute for Drive Systems and Power Electronics, Leibniz Universität Hannover

Further information:

<https://www.tth.uni-hannover.de/>

# International Wind Engineering Conference 2014 – Support Structures and Electrical Systems – (IWEC 2014)

## Introduction

Climate change and the dangers arising from the nuclear energy have led to a re-think in energy supply in German politics and society. The transformation of the energy system into regenerative energies, which is characterized as an energy transformation – here, in particular, wind power – is a major challenge for science and industry.

## Background

From 3 to 4 September 2014, the IWEC 2014 took place in Hanover at the Leibniz University. Organized by representatives of the Leibniz University, Fraunhofer IWES and the ForWind research group, the focus was on the exchange of current research results at an interdisciplinary level.

The main focus was on support structures, generators and power electronics as well as installation and operation. The "opening lecture", held by Jos Beurskens (ECN, Netherlands), focused on wind energy research with regard to cost reduction and cost-effectiveness. The three keynote lectures were held by Michael Muskulus (NTNU, Norway), Hans-Dietrich Haasis (University of Bremen, Germany) and Freede Blaabjerg (AAU, Denmark). The scientific contributions of the conference participants ranged from the use of air bubbles to the reduction of noise pollution during the construction of offshore wind turbines over the behavior of double-fed asynchronous machines in the case of network faults and structural health monitoring (SHM) in offshore wind energy installations.

Several presentations from industry representatives with new developments and innovations have been added to the agenda of the scientific lecture program.

Here, for example, the key supplier for offshore foundations is EEW Special Pipe Construction GmbH and the specialist in modern offshore engineering and design Overdick GmbH & Co. KG.

The IWEC 2014 was concluded with the ceremonial opening of the Test Center for Support Structures in the presence of the Prime Minister of Lower Saxony Stephan Weil and the Parliamentary State Secretary in the Federal Ministry for Economic Affairs and Energy, Uwe Beckmeyer. Additionally, the 83 participants of the IWEC and 160 invited representatives from academia and industry participated in the opening ceremony.

## Goals

The main objective during the IWEC 2014 planning phase was to enable and promote the exchange of current international research results at an interdisciplinary level. This has been quite successful with a total of 43 contributions, which were divided into 10 sessions.

With 18 contributions from Hanover, the Leibniz University also boosts its position as an international research centre in the field of wind energy.

The fact that the vast majority of participants did not originate from Hanover is another indication that the conference was well received in wind energy research. Including German scientists, the IWEC also attracted participants from 6 other nations, among them were representatives from Spain, Norway, the Netherlands, China and India. The large number of external conference participants also led to excellent networking opportunities for the scientific staff and professors from Hanover who were inspired by the pleasant atmosphere during the "Conference Reception".

The research infrastructure of the Leibniz University of Hanover was presented to a large audience at the ceremonial opening of the Test Center for Support Structures (TTH). With a total of almost 250 guests, the event, which was an integral part of IWEC, was very well attended. The lectures were held at the opening of the test center in the buildings of the large wave channel. Furthermore the research infrastructures were unveiled.

A particular focus here was on the foundation test pit and the span, where large-scale models can be tested for their offshore suitability. In addition to this, other specialized laboratories, which were located in the Test Center, were also opened and could be visited by the participants throughout the day.

## Conclusion

From the organizers point of view, the IWEC 2014 was thus regarded as a complete success. We were able to meet all of our targets in full.

The only deficit was, with regard to the previous planning work, the number of active conference participants. Some 200 active participants have been included in the conference. The EEG reform 2014 affected the IWEC indirectly. Due to the long-term unexplained revision of the EEG, 2014 is a difficult year for the wind energy industry. Scientific conferences on renewable energies were generally less frequented. Especially in industry, waiting for the reformed EEG has led to a decline in participation in scientific conferences. However, the small number of participants will not be considered a disadvantage for the IWEC. Despite less active contributions than expected, a lively scientific exchange took place. There was a lot of room for scientific discussions, which were highly intensive. The professional exchange between experts at the confer-

ence was appreciated by many participants. Again, there was a very positive feedback from the conference participants and guests. In addition, the unique research infrastructure at the Leibniz University was presented to a broad specialist audience of 250 people. The national, European and international networking of the Hanover Research Center in the area of wind energy could thus be promoted and the wind energy research in Hanover could be brought to a large audience.

## Outlook

Due to the positive feedback of conference participants and banquets, the IWEC 2014 is regarded as a great success. In the long-term view, scientific meetings in Hanover will be established as international conferences on wind energy engineering as part of a conference series in Lower Saxony.

# Research Alliance for Wind Energy at WindEnergy Hamburg, September 23rd – 26th

ForWind Head Office

Elke Seidel

Partners:

German Aerospace Centre (DLR)  
Fraunhofer Institute for Wind Energy and  
Energy Systems Technology (IWES)

At the trade fair Hamburg WindEnergy, September 23rd – 26th, the Research Alliance for Wind Energy of the three partners

German Aerospace Centre (DLR), ForWind – Center for Wind Energy Research and Fraunhofer Institute for Wind Energy and Energy Systems Technology (IWES) introduced its portfolio in research, development and higher education.

The research alliance welcomed visitors from all areas of research, industry and politics and used the occasion for several expert meetings. To demonstrate research topics and developments in a more vivid way, the research alliance presented a

modified drive train with lower service intensity, a rotor blade model with active flap system for load reduction, a rotor blade tool form with new production technology and a system for the early detection of damages in rotor blades. The focus on rotor blades was due to the joint research project of the research alliance “Smart Blades – Development and Construction of Intelligent Rotor Blades”.



## Forschungsverbund Windenergie



**Forschungsverbund**  
Windenergie

Gemeinsam forschen für den Wandel  
*Joint Research for the Age of Renewables*

FORSCHUNG		
	ENTWICKLUNG	
TEST- INFRASTRUKTUR		STUDIUM & WISSENSCHAFTLICHE WEITERBILDUNG



## Global Wind Day with ForWind

ForWind Head Office

Elke Seidel

"Global Wind Day" is a worldwide event that occurs annually on 15 June. It is a day for discovering wind, its power and the possibilities it holds to reshape our energy systems, decarbonise our economies and boost jobs and growth. (...) Global Wind Day is a coordinated action between the European Wind Energy Association, the Global Wind Energy Council and the national associations to introduce the general public to wind energy through a series of activities. In the run-up to 15th June, hundreds of public events will be held all over the world from family outings and wind farm visits to seminars with experts and leading industry figures.\*\*

Within the Global Wind Day 2014 ForWind supported the study group of pupils „Na, Erde?“ of the Neue Gymnasium, Oldenburg and the start of the event series „Junior Science Café“, a part of the research project „Wissenschaft debattieren“, funded by German Federal Ministry of Research and Technology (BMBF) at the Schlaues Haus Oldenburg.

The pupils organized and moderated an information evening about the design of wind turbines including a panel discussion. For the preparation ForWind welcomed the study group to clarify questions, discuss possibilities and provide exhibits. At the evening event ForWind was also part of the panel discussion.



\*Source: (<http://www.globalwindday.org/about-wind-day/>)



# Coordination Office ForWind at Leibniz Universität Hannover

## Summary of 2013 and 2014

The coordination office ForWind at Leibniz Universität Hannover (LUH) coordinates the research of LUH in the field of wind energy. New project ideas are collected and joint project proposals are coordinated. In order to realize this, the coordination office integrates all associate ForWind Institutes at LUH. The associated institutes are supported in acquisition of funded projects, in searching for suitable industry partners and in integration into research networks in Germany and abroad. This is done in close coordination with the ForWind main office in Oldenburg.

### 1. European Activities of the Coordination Office ForWind

As part of the associate EERA-Membership (European Energy Research Alliance) of ForWind-Hannover, the coordination office was involved in several activities in 2013 and 2014.

For the research project „InnWind.eu“, started in 2012, from the 7th framework programme of the EU, the coordination office took over the financial coordination between the involved ForWind-Members of LUH. The “Financial Report” was created and submitted to the EU-Commission. Therefore, a close cooperation with the project-coordinator as well as a carefully observance of the given EU guidelines is very important. The well internal communication structure between the involved ForWind-Members helps to work things out in an uncomplicated way.

Not only „InnWind.eu“ is supervised by the coordination office, there is also the research project “IRP-Wind” which is also funded by the 7th framework programme of the EU. In 2013, the coordination office was part of the application phase of the project and offered its help to the Hannover ForWind-Members. And even in the operative phase

of the project it took over some administrative work. This project is also accustomed by the coordination office in the field of finance. Similarly, it is responsible for the internal communication and the close cooperation with the project-coordinator and the EU-Commission. ForWind-Hannover was represented by the coordination office at the kick off-meeting, which was held in march 2014.

A very strong part of work did the coordination Office in 2014 while processing the project proposal COREWIND, directed by Professor Raimund Rolfes (ISD) for the EU program Horizon 2020. It accomplished an important part of the proposal by administrative work. The coordination office always stood in close touch with the LUH-project-participants as well as with the international participants from research and industry. To support the core group of the consortium, the coordination office offered assistance during the stage of application by administrative help at project meetings and conference calls. The project meetings in Hannover and Barcelona were both organized by the coordination office. It was responsible for the substantive work as well as for the preparation and the follow up of the meetings.

The coordination office took part in two EERA Horizon 2020 Workshops in 2014 to continue giving advice and support to the ForWind Institutes in Hannover regarding the application procedure for EU funded research projects.

### 2. Participation in conferences

The coordination office planned a miniSymposium named „Computational Methods in Offshore Wind Energy“ within the context of the ECCOMAS (European Community on Computational Methods in Applied Sciences) Conference on Computational Meth-

ods in Marine Engineering. The symposium was organized on behalf of the ForWind-Board members Professor Schaumann (IfS) and Professor Rolfes (ISD).

As a member of the EAWE (European Academy of Wind Energy), the coordination office attended the EAWE board meeting in Sweden in September 2013. Also on the EAWE PhD Seminar on Wind Energy, which ran parallel to the Board Meeting, the coordination office was present.

In 2014, the coordination office participated in the „EWEA Annual Conference “in Barcelona as well as in the „IRP-Wind Conference“ in Amsterdam.

The first „International Wind Engineering Conference – IWEC 2014“ took place in Hannover in September 2014. The conference was not only supported by contributions from the associated ForWind-Hannover Institutes, the accurate implementation of the two-day-Conference was also organized by the ForWind coordination office. The organization for the IWEC started already in 2012. The coordination office set up an internal organizing committee which worked out the pioneering way of the first IWEC in cooperation with the coordination office. To establish the IWEC internationally, the coordination office gave its help to support the internal organizing committee of the LUH to constitute the „Scientific Committee “as well as the „Organizing Committee“ with national and international scientists from the field of Wind energy.

With this support and with the cooperation to Fraunhofer-IWES, the “Call for Paper” could be placed on several distinguished organizations. The coordination office was not only responsible for planning the conference; it even cared about the financial aspect of the event. It put in an application for the public tender „Pro Niedersachsen“ of the Niedersächsisches Ministerium für Wis-

senschaft und Kultur (MWK). The MWK approved the application and funded the conference.

The two conference days in Hannover ended up with a highlight. In a ceremonial act the inauguration of the test center for support structures (TTH) was celebrated. Integrated into the conference planning, the inauguration of the TTH was also organized by the coordination office.

### 3. Representation of ForWind Hannover on Fairs and Exhibitions

The ForWind coordination office represented the ForWind-Alliance of Hannover on several national fairs and exhibitions in 2013 and 2014.

For the „Energieforschungsmesse“ of the „Leibniz Forschungsinitiative Energie 2050“ (now: Leibniz Forschungszentrum Energie 2050) the coordination office organized an extensive exhibition of posters from the current ForWind Hannover research projects. Thereby a detailed overview of the varied field of research from ForWind Hannover was given. A wind turbine blade from the Institute of Structural Analysis and an inspection robot for rotor blades of wind turbines designed and built by a mechanical engineering student were also organized by the coordination office to be shown at the fair.

Even on the „Zukunftsenergien Nordwest“, the job fair in Bremen, the coordination office presented in 2013 the wind turbine blade as well as the Master's degree in wind energy engineering of the LUH. This master's degree was also presented at the following job fair in Oldenburg in 2014.

As part of the Research Alliance of Wind energy (FVWE) the coordination office took part in the “WindEnergy Hamburg 2014”. On the common exhibition stand of the FVWE, the coordination office represented the associated ForWind partners from Hannover.

### 4. Teaching in the field of wind energy at Leibniz Universität Hannover

Due to the positive feedback of conference participants and banquets, the IWEC 2014 is regarded as a great success. In the long-term view, scientific meetings in Hannover will be established as international conferences on wind energy engineering as part of a conference series in Lower Saxony.

### 5. Support of the Test Center for Support Structures Hannover (TTH)

During the two-year period of building the Test Center, the coordination office did supporting work to help building and to commission the Test Center.

### 6. Cooperation with the Research Alliance of Wind Energy (FVWE)

ForWind is one of three strong partners within the research alliance. The Fraunhofer Institutes für Windenergie und Energiesystemtechnik (IWES) North-West, the German Aerospace Center (DLR) and ForWind are part of a common network.

The coordination office gives technical advice to the FVWE-Partners and supports them in planning and permission processes regarding installation of research-wind-turbines (DLR and ForWind). It was on-site in Wieringermeer, Netherlands with the alliance partners of ForWind and DLR to carry out subject-specific inquiries at the testpark of the Energy Research Centre of the Netherlands (ECN).

During the further process the coordination office took part in the permission process for the FVWE-Testpark as well as in talks with the regarding city government. And even the meetings with all project partners in Hannover were organized by the coordination office.

To ensure a constant flow of information within the FVWE a weekly exchange is held with the Alliance-Partners via confer-

ence call. Also, the coordination office takes part in these regular discussions and is continuously informed about the latest research projects and problems.

In October 2013, the first Colloquium of the FVWE was held in Bremen. The coordination office was on-site to exchange information and experiences between the Alliance-Partners.

# Documentation

## Publication Lists

### Peer Reviewed Articles

Achmus, M., Akdag, C.T., Thieken, K.:  
**Load-bearing behavior of suction bucket foundations in sand**  
Applied Ocean Research (43), pp. 157-165 (2013)

Bastine, D., Witha, B., Wächter, M., Peinke, J.:  
**POD Analysis of a Wind Turbine Wake in a Turbulent Atmospheric Boundary Layer**  
J. Phys.: Conf. Ser., 524, 012153, doi:10.1088/1742-6596/524/1/012153, (2014)

Dörenkämper, M., Tambke, J., Steinfeld, G., Heinemann, D., Kühn, M.:  
**Atmospheric Impacts on Power Curves of Multi-Megawatt Offshore Wind Turbines**  
J. Phys.: Conf. Ser., 555, 012029, (2014)

Dubois, J.; Muskulus, M.; Schaumann, P.:  
**Advanced Representation of Tubular Joints in Jacket Models for Offshore Wind Turbine Simulation**  
DeepWind Conference, Trondheim, Norway, Energy Procedia, Elsevier Ltd. (2013)

Garcia Sanchez, R.; Pehlken, A.; Lewandowski, M.:  
**On the sustainability of wind energy regarding material usage**  
Acta Technica Cornviniensis, 7, pp. 69-76 (2014)

Häckell, M. W.; Rolfes, R.:  
**Monitoring a 5MW offshore wind energy converter – Condition parameters and triangulation based extraction of modal parameters**  
Mechanical Systems and Signal Processing, 40(1), pp. 322-343. (2013)  
Link: <http://linkinghub.elsevier.com/doi/pii/S0888327013001908>  
doi:10.1016/j.ymssp.2013.04.004

Hansen, M.; Schmidt, B.:  
**Sicherheit von Offshore Windenergieanlagen**  
Bautechnik 91, Heft 8, pp. 525-532, DOI: 10.1002/bate.201400048 (2014)

Hassel, T., Konya, R., Schaumann, P., Collmann, M., Priebe, S., Deißer, T.A., Beniyash, A., Murray, N., Bach, Fr.-W.:  
**Economical joining of tubular steel towers for wind turbines employing non-vacuum electron beam welding for high-strength steels in comparison with submerged arc welding**  
Welding in the World, Vol. 57, pp. 551-559, Springer Verlag. (2013)

Hofmeister, P. G.; Bollig, C.; Fayed, S.; Kunze, M.; Reuter, R.:  
**A compact Doppler wind lidar for controlling the operation of wind turbines**  
EARSeL eProceedings, 14(1), 1-12; [http://www.e proceedings.org/static/vol14\\_1/14\\_1\\_hofmeister1.html](http://www.e proceedings.org/static/vol14_1/14_1_hofmeister1.html) (2015)

Junk, C., von Bremen, L., Kühn, M., Späth, S., Heinemann, D.:  
**Comparison of Postprocessing Methods for the Calibration of 100-m Wind Ensemble Forecasts at Off- and Onshore Sites**  
J. Appl. Meteor. Climatol., 53, pp. 950-969, (2014)

Kelma, S.; Schmoor, K.; Werner, M.; Goretzka, J.; Hansen, M.:  
**Sicherheitsaspekte der Tragstruktur von Offshore-Windenergieanlagen**  
Bautechnik 91 (8), pp. 543-553 (2014)

Knebel, P.; Kittel, A.; Peinke, J.:  
**Atmospheric Wind Field Conditions Generated by Active Grids**  
Experiments in Fluid, 51, pp. 471-481 (2011)

Lohaus, L.; Schaumann, P.; Lochte-Holtgreven, S.; Bechtel, A.; Griese, R.; Lindschulte, N.:  
**Zustimmungen im Einzelfall für Grout-Verbindungen in Tragstrukturen für die Offshore-Windenergie**  
Bautechnik, Vol. 90, pp. 402-409, Ernst & Sohn Verlag. (2013)

Pehlken, A.; Decker, A.; Kirchner, A.; Kottwoski, C.; Thoben, K.-D.:  
**Energy Efficiency in processing of natural raw materials under consideration of uncertainties**  
Journal of Cleaner Production, (In Press) (2014)

Reuter, A.; Rollert, B.:  
**Nachhaltige Energieversorgung – das Potenzial der Windenergie**  
In: Fouad, N. A.: Bauphysikkalender 2013, Wilhelm Ernst & Sohn, Berlin, Germany, pp. 57-68, ISBN: 978-3433030196 (2013)

Rolfes, R.; Schaumann, P.; Achmus, M.; Huhn, H.; Lohaus, L.; Schlurmann, T.:  
**Ganzheitliches Dimensionierungskonzept für OWEA-Tragstrukturen anhand von Messungen im Offshore-Testfeld alpha ventus – Abschlussbericht GIGAWIND alpha ventus**  
In: Raimund Rolfes und Peter Schaumann (ed.): Berichte aus dem Bauwesen  
Herausgeber: Shaker Verlag, Aachen (2013) ISBN: 978-3-8440-1762-5

- Schaumann, P.; Bechtel, A.:  
**Konstruktions- und Planungsaspekte von Offshore-Windenergieanlagen**  
Bauingenieur VDI-Bautechnik Jahressausgabe 2013/2014, Vol. 88, pp. 81-83, Springer-VDI-Verlag. (2013)
- Schaumann, P.; Bechtel, A.:  
**Nachhaltigkeitsbewertung stählerner Tragkonstruktionen von Windenergieanlagen**  
Stahlbau, Vol. 82, pp. 665-670, Ernst & Sohn Verlag. (2013)
- Schaumann, P.; Collmann, M.:  
**Influence of Weld Defects on the Fatigue Resistance of Thick Steel Plates**  
5th Fatigue Design Conference, Senlis, Procedia Engineering, Elsevier Ltd. (2013)
- Schaumann, P.; Steppeler, S.:  
**Fatigue tests of axially loaded butt welds up to very high cycles**  
5th Fatigue Design Conference, Senlis, Procedia Engineering, Elsevier Ltd. (2013)
- Schaumann, P.; Gottschalk, M.:  
**Numerically based assessment of suction bucket foundation shells, Proceedings of Shell Structures**  
Proceeding of Shell Structures : Theory and Applications, Gdansk, Poland, Vol. 3, pp. 559-562, Engineering, ISBN 978-1-138-00082-7 (2013)
- Schlipf, D.; Schlipf, D. J.; Kühn M.:  
**Nonlinear Model Predictive Control of Wind Turbines Using LIDAR**  
Wind Energy, Vol. 16, no. 7, pp. 1107-1129, October 2013
- Shimada, S., Ohsawa, T., Kogaki, T., Steinfeld, G., Heinemann, D.:  
**Effects of sea surface temperature accuracy on offshore wind resource assessment using a mesoscale model**  
**Wind Energy**, doi:10.1002/we.1796, (2014)
- Schmidt, B.; Ernst, B.; Wilms, M.; Hildebrandt, A.; Hansen, M.:  
**Messdatenbasierte Empfehlungen von Wind- und Wellenparametern für die Auslegung von Offshore-Windenergieanlagen**  
Bautechnik 91, Heft 8, pp. 533-542. DOI: 10.1002/bate.201400033 (2014)
- Schmidt, B.; Göthel, O.; Göhlmann, J.; Grünberg, J.; Marx, S.:  
**Wellenbeanspruchung auf hydrodynamisch kompakte Betonstrukturen für Offshore-Windenergieanlagen**  
Beton- und Stahlbetonbau Vol. 109, Issue 4, pp. 265-274, April 2014
- Stranghöner, N.; Berg, J.; Gorbachov, A.; Schaumann, P.; Bechtel, A.; Eichstädt, R.; Wagner, H.-J.; Baack, C.; Lohmann, J.:  
**Nachhaltigkeitsbewertung stählerner Tragkonstruktionen Erneuerbarer Energien**  
Stahlbau, Vol.82, pp. 42-48 (2013)
- Thiemann, P.; Geilert, P.; Wagner, A.:  
**Schleifbrand - Ansätze zur Erkennung und Vermeidung beim Verzahnungsschleifen**  
In: 4. Kongress zur Getriebeproduktion, GETPRO, Würzburg, pp. 209-221. (2013)
- Turker, B., Arroyo Klein, S., Komsiyyska, L., Trujillo, J. J., von Bremen, L., Kühn, M., Busse, M.:  
**Utilizing a vanadium redox flow battery to avoid wind power deviation penalties in an electricity market**  
Energy Conversion and Management, 76, pp. 1150-1157, (2013)
- von Freyberg, A.; Stöbener, D.; Lübke, K.; Goch, G.:  
**Flexible manufacturing of modified involute gears**  
The proceedings of MTTRF 2013 Meeting, San Francisco, California, USA, pp. 143-160. (2013)
- Witha, B., Steinfeld, G., Dörenkämper, M., Heinemann, D.:  
**Large-eddy simulation of multiple wakes in offshore wind farms**  
J. Phys.: Conf. Ser., 555, 012108, doi:10.1088/1742-6596/555/1/012108, (2014)
- Witha, B., Steinfeld, G., Heinemann, D.:  
**High-resolution offshore wake simulations with the LES model PALM**  
Wind Energy – Impact of Turbulence, Research Topics in Wind Energy 2, pp. 175-181, Springer Berlin Heidelberg, doi: 10.1007/978-3-642-54696-9\_26, (2014)

Articles,  
Conference Proceedings,  
Conference Contributions

Abdel-Rahman, K., Achmus, M.,  
Kuo, Y.-S.:

**A New Approach for the Derivation of  
Interaction Diagrams for Piles under  
Cyclic Axial Loading**

8th International Conference on  
Structural and Geotechnical Engineering,  
Alexandria, Egypt (2014)

Abdel-Rahman, K., Achmus, M.,  
Kuo, Y.-S.:

**A Numerical Model for the Simulation  
of Pile Capacity Degradation under  
cyclic axial Loading**

8th European Conference on Numerical  
Methods in Geotechnical Engineering  
(NUMGE), Delft, The Netherlands  
(accepted) (2014)

Achmus, M., Thieken, K., Akdag, C.T.,  
Schröder, C., Spohn, C.:

**Load bearing behavior of bucket  
foundations in sand**

Proceedings of the 3rd International  
Symposium on Computational Geome-  
chanics (ComGeo III), Krakow, Poland,  
pp. 586-597 (2013)

Barth, S.:

**Wind Power Plants – it's more than  
just turbines. Where R&D supports the  
industry.**

invited talk 5th TOWER Conference,  
Houston, TX, USA, Sept. 10th 2014

Barth, S.:

**Technologische Herausforderungen  
und Entwicklungen der Windenergie**

invited talk 5th TOWER Conference,  
Houston, TX, USA, Sept. 10th 2014

Baruschka, L.; Mertens, A.:

**A New 3-Phase Direct Modular  
Multi-level Converter**

Proceedings of the 14th European  
Conference on Power Electronics and  
Applications, 2011, EPE 2011, pp. 1-10  
(2011)

Bastine, D., Witha, B., Wächter, M.,  
Peinke, J.:

**POD Analysis of a Wind Turbine Wake  
in a Turbulent Atmospheric Boundary  
Layer**

The Science of Making Torque from Wind  
2014, Copenhagen, Denmark,  
June 18th-20th 2014

Böske, L.; Heinze, R.; Raasch, S.:

**A Continuous Large Eddy Simulation  
Covering Multiple Days and Wea-  
ther Conditions in the Mid-Latitudes**

ACEEES Forum 2014, Dec. 12th-16th 2014,  
Perth, Western Australia, Australia

Bollig C.; Hofmeister, P. G.; Kunze, M.;  
Schmidt, J.; Fayed, S.; Reuter, R.:

**Efficient single-frequency pulsed  
all-fire amplifier for coherent lidar**

European Conference on Lasers and  
Electro-Optics and XIIIth International  
Quantum Electronics Conference CLEO  
EUROPE/IQEC, 1 S., doi: 10.1109/CLEOE-  
IQEC.2013.6801383 (2013)

Brand, C.R.; Seume, J.R.:

**Quantifizierung der globalen Schall-  
emission eines skalierten Flügelprofils  
mit Hinterkantenklappe für  
Windenergieanlagen**

40. Jahrestagung für Akustik – DAGA  
2014, Oldenburg, Germany,  
March 10th-13th 2014

Brand, C.R.; Seume, J.R.:

**Flaps for Wind Turbine Applications:  
Noise Source Localization on a Test  
Airfoil**

10th EAWE PhD. Seminar on Wind Energy  
in Europe 2014, Orléans, France,  
Oct. 28th-31th 2014

Brand, C.R.; Seume, J.R.:

**Flaps for Wind Turbine Applications:  
First Results of the Experimental  
Investigations**

Wind Turbine Sound 2014 - EWEA Techno-  
logy Workshop, Malmö, Sweden, Dec.  
9th-10th 2014

Brand, A.; Bot, E.; Özdemir, H.;  
Steinfeld, G.; Drüke, S.; Schmidt, M.;  
Mittelmeier, N.:

**Accurate wind farm development and  
operation – Advanced wake modelling**  
Proceedings of the EWEA Offshore 2013,  
2013, EOW2013, pp. 1-10. (2013)

Brand, A.; Bot, E.; Özdemir, H.;  
Steinfeld, G.; Drüke, S.; Schmidt, M.;  
Mittelmeier, N.:

**Accurate wind farm development and  
operation – Advanced wake modelling**  
EWEA Offshore 2013, Frankfurt, Germany  
November 19th-21th 2013

Dörenkämper, M., Optis, M.,  
Monahan, A., Steinfeld, G.,  
Heinemann, D.:

**On the impact of sea fetch, roughness  
lengths and atmospheric stability on  
offshore winds**

Proceedings of Grand Renewable Energy  
2014, pp. 1-4, (2014)

Dörenkämper, M.; Steinfeld, G.;  
Witha, B.; Drüke, S.; Heinemann, D.;  
Kühn, M.:

**Influence of the atmospheric boundary  
layer on wind turbine wakes within  
the offshore wind farm EnBW Baltic 1**

EMS, Reading (UK), August 9th-13th 2013

Dörenkämper, M.; Witha, B.;  
Steinfeld, G.; Tambke, J.; Heinemann, D.;  
Kühn, M.:

**Influence of the atmospheric boundary  
layer on wind turbine wakes within  
the offshore wind farm EnBW Baltic 1**

13th EMS Annual Meeting & 11th Eu-  
ropean Conference on Applications of  
Meteorology, Reading, United Kingdom,  
September 9th-13th 2013

Dörenkämper, M., Witha, B.,  
Steinfeld, G., Heinemann, D., Kühn, M.:  
**An LES study of wind turbine wakes  
within the offshore wind farm EnBW  
Baltic 1**

14th EMS Annual Meeting, Prague, Czech  
Republic,  
October 6th-10th 2014

Dörenkämper, M., Optis, M.,  
Monahan, A., Steinfeld, G.,  
Heinemann, D.:

**On the impact of sea fetch, roughness lengths and atmospheric stability on offshore winds**

Grand Renewable Energy 2014, Tokyo, Japan,  
July 27th-August 1st 2014

Dörenkämper, M., Witha, B.,  
Steinfeld, G., Heinemann, D., Kühn, M.:

**The role of stable atmospheric boundary layers on wind turbine wakes within offshore wind farms**

6th International Symposium on Computational Wind Engineering (CWE 2014), Hamburg, Germany,  
June 8th-12th 2014

Dollinger, C.:

**Messverfahren zur akustisch-aerodynamischen Optimierung von Rotorblättern im Windkanal**

DFMRS-Windenergetagung 2013.  
Bremen, Nov. 7th 2013.

Droste, R., Hahn A.

**Modellbasierte Planung und Analyse von Offshore-Operationen**

Torsten Eymann, Editor, Doctoral Consortium im Vorfeld der 11. Internationalen Tagung Wirtschaftsinformatik 2013, volume No. 54 of Bayreuther Arbeitspapiere zur Wirtschaftsinformatik, pp.74–81. Lehrstuhl für Wirtschaftsinformatik – Information Systems Management, Universität Bayreuth,  
February 2013

Drüke, S.; Steinfeld, G.; Witha, B.;  
Dörenkämper, M.:

**Comparison of Large-Eddy Simulation and Engineering Wake Model Results for Offshore and Onshore Sites**

13th EMS Annual Meeting & 11th European Conference on Applications of Meteorology, Reading, United Kingdom,  
September 9th-13th 2013

Drüke, S., Janssen, N., Steinfeld, G.:

**How do uncertainties of numerical weather forecasts propagate into power predictions for offshore wind farms?**

14th EMS Annual Meeting, Prague, Czech Republic,  
October 6th-10th 2014

Drüke, S., Witha, B., Steinfeld, G.:

**Comparison between model results and measurements to determine the quality of the models**

6. International Symposium on Computational Wind Engineering (CWE 2014), Hamburg, Germany,  
June 8th-12th 2014

Drüke, S., Steinfeld, G., Heinemann, D.,  
Günther, R.:

**Generation of a wind and stability atlas for the optimized utilization of offshore wind resources in the North Sea Region**

EGU General Assembly 2014, Vienna, Austria,  
April 27th-May 2nd 2014

Dubois, J.; Muskulus, M., Schaumann, P.:

**Advanced Representation of Tubular Joints in Jacket Models for Offshore Wind Turbine Simulation**

DeepWind 2013 Conference,  
January 24th-25th, Trondheim, Norway  
(2013)

Ernst, B.; Schmitt, H.; Seume, J.R.:

**Effect of Geometric Uncertainties on the Aerodynamic Characteristic of Offshore Wind Turbine Blades**

The Science of Making Torque from Wind 2012, Journal of Physics: Conference Series 555 012033 DOI:10.1088/1742-6596/555/1/012033. (2014)

Ernst, B.; Seume, J.R.:

**Modelling Structural Uncertainty of Wind Turbine Rotor Blades for Aeroelastic Investigations**

Seventh M.I.T. Conference on Computational Fluid and Solid Mechanics - Focus: Multiphysics & Multiscale,  
June 12th-14th, 2013, Massachusetts Institute of Technology, Cambridge, MA 02139 USA (2013)

Fein, F.; Schmidt M.; Groke, H.; Orlik, B.:

**A Paradigm Change in Wind Power Station Control through Emulation of Conventional Power Plant Behaviour**

15th European Conference on Power Electronics and Applications (EPE), 2013, EPE 2013, pp. 1-10 (2013)

Fein, F., Orlik, B.:

**Dual HVDC system with line- and self-commutated converters for grid connection of offshore wind farms**

International Conference on Renewable Energy Research and Applications (ICRERA), 2013, ICRERA 2013, pp. 280-285 (2013)

Franke, J.:

**Entwicklung von Handhabungseinrichtungen für biegeeweiche Materialien – Herausforderungen einer kontinuierlichen Direktablage**

Kolloquium des Forschungsverbund Windenergie, Braunschweig,  
Nov. 12th 2014

Garcia Sanchez, R.; Pehlken, A.;  
Lewandowski, M.:

**Potential usage for used glass fibre reinforced plastics (GFRP) and carbon fibre reinforced plastics (CFRP)**

Proceedings of 4th International Conference on Industrial and Hazardous Waste Management, pp. XX-XX (2014)

Häckell, M. W.; Rolfes, R.:

**Long-term Monitoring of Modal Parameters for SHM at a 5 MW Offshore Wind Turbine**

Proceedings of the 9th International Workshop on Structural Health Monitoring, 1310-1317. Chang, F.-K. (Ed.), DEStech Publications Inc., Stanford, CA, USA, (2013)

Hahn, A.:

**Risk Assessment of Human Machine Interaction for Control and Navigation Systems of Marine Vessels**

IFAC Conference on Control Application in Marine Systems, Osaka, in Control Applications in Marine Systems, Volume# 9, Part# 1, ISBN: 978-3-902823-52-6, IFAC, 2013

Hahn, A.:

**Human Factors**

eNavigation Usability Workshop, 2013-03-05, AMSA Kingscliff, Australien  
Hahna.  
IMO eNavigation Standardisierung, DGON Workshop, May 15th 2013, DGON, Hamburg

Heinemann, D.:

**Energiemeteorologie: Forschung für eine neue Energieversorgung**

3. Fachtagung Energiemeteorologie, Grainau, Germany, June 4th-6th 2013

Hinrichs, C.; Bremer, J.;

Sonnenschein, M.:

**Distributed Hybrid Constraint Handling in Large Scale Virtual Power Plants**

IEEE PES Conference on Innovative Smart Grid Technologies Europe (ISGT Europe) (2013)

Hofmeister P. G.; Bollig, C.; Kunze M.;

Reuter, R.:

**A Doppler lidar for remote sensing of wind fields in offshore wind farms**

6th EARSeL Workshop on Remote Sensing of the Coastal Zone, June 7th-9th 2013, Matera (Italy)

Hofmeister P. G. Bollig, C.; Kunze, M.;

Fayed, S.; Bayrak, L. M.; Reuter, R.:

**A Doppler lidar for remote sensing of wind fields in offshore wind farms**

34th EARSeL Symposium, June 16th-20th 2014, Warschau, Poland

Hornauer, S., Hahn, A.:

**Towards Marine Collision Avoidance Based on Automatic Route Exchange**

IFAC Conference on Control Application in Marine Systems, Osaka, in Control Applications in Marine Systems, Volume# 9, Part# 1, ISBN: 978-3-902823-52-6, IFAC, 2013

Junk, C.; von Bremen, L.; Heinemann, D.:

**Reforecast-based calibration of probabilistic wind predictions**

EWEA 2013 Annual Event, Vienna, Austria, February 4th-7th 2013

Junk, C.; von Bremen, L.; Heinemann, D.;

Kühn, M.

**Calibration of ensemble wind forecasts for wind energy applications**

EWEA 2013, Vienna, Austria, February 4th-7th 2013

Junk, C.; von Bremen, L.; Kühn, M.; Späth,

S.; Heinemann, D.:

**Calibration of ensemble wind forecasts at on- and offshore sites**

PhD Workshop on System Integration of Renewable Energy, Delmenhorst, 2013

Junk, C.; von Bremen, L.; Heinemann, D.;

Späth, S.:

**Calibration of ensemble wind forecasts for wind energy applications**

13th EMS Annual Meeting & 11th European Conference on Applications of Meteorology, Reading, United Kingdom, September 9th-13th 2013

Junk, C., Delle Monache, L.,

Alessandrini, S., von Bremen, L.,

Späth, S.:

**Optimizing the analog ensemble for probabilistic wind power forecasting at four on and offshore wind farms**

14th EMS Annual Meeting, Prague, Czech Republic, October 6th-10th 2014

Kärn, M:

**Windenergie studieren – in Vollzeit und berufsbegleitend**

Energie Interdisziplinär, Oldenburg May 21st 2014

Kärn, M:

**Das berufsbegleitende Offshore-Windstudium: Continuing Studies Programme Offshore Wind Energy**

8. Euroforum-Konferenz: Herausforderung Offshore-Windpark, Hamburg January 29th 2014

Kärn, M.,

**Educating Experts and Executives: Continuing Studies Programme Offshore Wind Energy**

EWEA OFFSHORE 2013, Frankfurt November 20th 2013

Kärn, M., Schwarzer, C.:

**Workshop Windenergie**

Wissensdrehscheibe Energie, Oldenburg September 2nd 2013

Kärn, M.:

**Continuing Studies Programmes in Onshore and Offshore Wind Energy**

SEEIT Workshop, Oldenburg April 25th 2013

Kapp, S.; Heß, F.; Kühn, M.:

**Sensitivity of Lidar Measurement Chain Uncertainties on Wind Turbine Load Reductions Applying Feedforward Pitch Control**

European Wind Energy association Conference (EWEA 2013)

Kies, A., von Bremen, L., Heinemann, D., Nag, K., Lorenz, E.:

**Impacts of North African CSP and Norwegian hydro power on storage needs in an European energy system dominated by Renewables**

Proc. Of Wind Integration Workshop 2014, pp. 1-6, (2014)



Kies, A., Nag, K., von Bremen, L.,  
Lorenz, E., Heinemann, D.:

**Simulation of long term renewable energy feed-in for European power system studies**

EGU General Assembly 2014, Vienna, Austria,  
April 27th-May 2nd 2014

Kies, A., von Bremen, L., Nag, K.,  
Lorenz, E., Heinemann, D.:

**Investigation of balancing effects in long term renewable energy feed-in with respect to the transmission grid**

14th EMS Annual Meeting, Prague, Czech Republic,  
October 6th-10th 2014

Kies, A., von Bremen, L., Heinemann, D.,  
Nag, K., Lorenz, E.:

**Impacts of North African CSP and Norwegian hydro power on storage needs in an European energy system dominated by Renewables**

Wind Integration Workshop 2014, Berlin, Germany,  
November 11th-13th 2014

Knigge, C.; Raasch, S:

**Analysis of one- and two-dimensional mean gust shapes using a large-eddy simulation model**

6. International Symposium on Computational Wind Engineering, Hamburg, Germany (2014)

Kramer, O., Treiber, N. A.,  
Sonnenschein, M.:

**Wind Power Ramp Event Prediction with Support Vector Machines**

Hybrid Artificial Intelligence Systems, Lecture Notes in Computer Science Volume 8480, pp. 37-48 (2014)

Läsche, C.; Gollücke, V.; Hahn, A.

**Using an HLA Simulation Environment for Safety Concept Certification of Offshore Operations**

Webjørn Rekdalsbakken, Robin T. Bye, Houxiang Zhang, editors, 27th European Conference on Modelling and Simulation, pp. 156–162. European Council for Modeling and Simulation, 2013.

Lewandowski, L.; Oelker, S.;  
Garcia Sanchez, R.; Thoben, K.D.:

**Closed-Loop Product Life Cycle Management for Offshore Wind Turbines by utilising Enhanced Maintenance Concepts**

Proceedings of International Wind Engineering Conference, IWECC 2014, pp. 421-428 (2014)

Mehrens, A., von Bremen, L.,  
Heinemann, D.:

**The relation between spatial and temporal mesoscale wind fluctuations**

14th EMS Annual Meeting, Prague, Czech Republic,  
October 6th-10th 2014

Mittelmeier, N.; Amelsberg, S.;  
Blodau, T.; Brand, A.; Drüke, S.; Kühn, M.;  
Neumann, K.; Steinfeld, G.:

**Wind farm performance monitoring with advanced wake models**

Proceedings of the EWEA Offshore 2013, 2013, EOW2013, pp. 1-10. (2013)

Mittelmeier, N.; Amelsberg, S.; Blodau, T.;  
Brand, A.; Drüke, S.; Kühn, M.;  
Neumann, K.; Steinfeld, G.:

**Wind farm performance monitoring with advanced wake models**

EWEA Offshore 2013, Frankfurt, Germany  
November 19th-21th 2013

Mittelmeier, N.; Amelsberg, S.; Blodau, T.;  
Brand, A.; Drüke, S.; Kühn, M.;  
Neumann, K.; Steinfeld, G.:

**Wind farm performance monitoring with advanced wake models**

Proceedings of the EWEA Offshore 2013, 2013, EOW2013, pp. 1-10

Nag, K., Lorenz E., Kies, K., von Bremen, L.,  
Heinemann, D.:

**Simulation of long term solar power feed-in and solar balancing potential in European countries**

14th EMS Annual Meeting, Prague, Czech Republic,  
October 6th-10th 2014

Ohlendorf, J.-H.; Rolbiecki, M.;  
Thoben, K.-D.:

**Entwicklung von Handhabungseinrichtungen für biegeeweiche Materialien – Anforderungsanalyse zur Produktentwicklung.**

Proceedings of 11th Gemeinsames Kolloquium Konstruktionstechnik, KT2013, pp. 305-314 (2013)

Ohlendorf, J.-H., Rolbiecki, M.;  
Thoben, K.-D.:

**The mapretec research project – automation technology for rotor blade production (part I),**

2nd Conference Advances in Rotor Blades for Wind Turbines, Bremen,  
Feb. 25th-27th 2013

Ohlendorf, J.-H., Thoben, K.-D.:

**Entwicklung von Handhabungstechnologien zur automatisierten Herstellung von FKV – Eine Frage der Materialeigenschaften,**

4. VDI-Fachkonferenz Rotoren und Rotorblätter von Windenergieanlagen, Bremen, May 21st-22nd 2014

Ohsawa, T.; Shimada, S.; Heinemann, D.;  
Steinfeld, G.; Schmidt, M.; von Bremen, L.;  
Tambke, J.:

**Offshore wind resource maps in German coastal waters based on WRF simulation**

Proceedings of the EWEA Offshore 2013, 2013, EOW2013, pp. 1-8. (2013)

Ohsawa, T.; Shimada, S.; Heinemann, D.;  
Steinfeld, G.; Schmidt, M.;  
von Bremen, L.; Tambke, J.:

**Offshore wind resource maps in German coastal waters based on WRF simulation**

EWEA Offshore 2013, Frankfurt, Germany  
November 19th-21th 2013

Ortega Gómez, J.; Balzani, C.:

**Load Reduction Potential on Large Wind Turbines Using Active Trailing Edge Flaps**

Conference of the Wind Power Community (COWEC), VDI Wissensforum, Berlin, Germany,  
June 18th-19th 2013

Ortega Gómez, J.; Balzani, C.; Reuter, A.:  
**Effect of Trailing Edge Flaps on Load Reduction of Large Wind Turbines**  
PhD Seminar, Bremerhaven, Germany, June 26th 2013

Perrone, F.; Kühn, M.  
**Hydrodynamic and aerodynamic loads alleviation of an offshore wind turbine by adaptive control**  
EAWE 9th PhD Seminar, Gotland, Sweden, September 18th–20th 2013

Reuter, A.:  
**How to Improve Turbine Reliability**  
China Wind Power 2013, Beijing, China, October 16th–18th 2013

Reuter, A.:  
**Bedeutung der Sensorik für die Energiewende**  
Fachtagung Sensorik für erneuerbare Energien und Energieeffizienz des FVEE und des AMA Fachverbandes für Sensorik, Berlin, Germany, 2013

Rolbiecki, M.; Diecks K.:  
**Handhabung textiler Halbzeuge in der Prozesskette zur Fertigung von Rotorblättern für WEA**  
Proceedings of Logistik für die Windenergie – Herausforderungen und Lösungen für moderne Windkraftwerke, pp. 151–159 (2014)

Rolbiecki, M.; Ohlendorf, J.-H.; Thoben, K.-D.:  
**Einsatz virtueller und experimenteller Methoden im Produktentwicklungsprozess von Effektoren für technische Textilien**  
Proceedings of 12th Gemeinsames Kolloquium Konstruktionstechnik, KT2014, pp. 23–32 (2014)

Rustemeier, J.; Griebmann, T.; Rolfes, R.:  
**Modelle zur Berechnung der Schallminderung von Blasenschleiern**  
AK Hydroschall, Hamburg, Germany (2013)

Santos-Alamillos, F.J.; von Bremen, L.; Heinemann, D.; Pozo-Vázquez, D.; Ruiz-Arias, J.A.; Tovar-Pescador, J.; Lara-Fanego, A.; Linares-Rodríguez, A.; Martínez-Valenzuela, J.; Arbizu-Barrena, C.; Quesada-Ruiz, S.; Junk, C.:  
**Sensitivity analysis of the WRF model to different PBL parameterization schemes for reproducing wind speed fluctuations associated with convective phenomena in the North Sea**  
13th EMS Annual Meeting & 11th European Conference on Applications of Meteorology, Reading, United Kingdom, September 9th–13th 2013

Schaumann, P.; Bechtel, A.; Lochte-Holtgreven, S.:  
**Grouted Joints for Offshore Wind Turbine Jackets under Full Reversal Axially Loading Conditions**  
Proceedings of the Twenty-third International Offshore and Polar Engineering Conference, Anchorage, Alaska, USA, pp. 173–180, ISBN 978-1-880653-99-9, ISSN 1098-9189 (2013)

Schaumann, P.; Bechtel, A.; Lochte-Holtgreven, S.; Lohaus, L.; Lindschulte, L.; Griese, R.:  
**Approvals for Grouted Joints in Offshore Structures in Germany**  
Proceedings of EWEA 2013, February 4th – 7th 2013, Vienna, Austria (2013)

Schaumann, P.; Bechtel, A.; Lochte-Holtgreven, S.:  
**Grouted Joints for Offshore Wind Turbine Jackets under Full Reversal Axially Loading Conditions**  
Twenty-third International Offshore and Polar Engineering Conference, Anchorage, Alaska, USA Conference, June 30th–July 5, Anchorage, Alaska, USA (2013)

Schaumann, P.; Bechtel, A.; Lochte-Holtgreven, S.; Lohaus, L.; Lindschulte, L.; Griese, R.:  
**Approvals for Grouted Joints in Offshore Structures in Germany**  
EWEA 2013, February 4th–7th, Vienna, Austria (2013)

Schaumann, P.; Collmann, M.:  
**Influence of Weld Defects on the Fatigue Resistance of Thick Steel Plates**  
5th Fatigue Design Conference, November 27th–28th, Senlis (2013)

Schaumann, P.; Dubois, J.; Gottschalk, M.:  
**Komplexe Modelle zur Lastsimulation und Ermüdungsberechnung von Tragstrukturen für Offshore-Windenergieanlagen**  
Proceedings of the Darmstädter Ingenieurkongress, ISBN 978-3-8440-1747-2 (2013)

Schaumann, P.; Dubois, J.:  
**Advanced simulation models of jackets for offshore wind turbines**  
EWEA 2013, February 4th–7th, Vienna, Austria (2013)

Schaumann, P.; Lochte-Holtgreven, S.; Eichstädt, R.; Camp, T.; McCann, G.:  
**Numerical Investigations on Local Degradation and Vertical Misalignments of Grouted Joints in Monopile Foundations**  
Proceedings of the Twenty-third International Offshore and Polar Engineering Conference, Anchorage, Alaska, USA, pp. 164–179, ISBN 978-1-880653-99-9, ISSN 1098-9189 (2013)

Schaumann, P.; Lochte-Holtgreven, S.:  
**A Novel Plasticity-Based Failure Model for Grouts in Grouted Joints for Offshore Wind Turbines with Monopiles**  
Proceedings of the V International Conference on Computational Methods in Marine Engineering, Brinkmann, B. and Wriggers, P. (Eds), ISBN 978-84-941407-4-7 (2013)

Schaumann, P.; Lochte-Holtgreven, S.; Eichstädt, R.; Camp, T.; McCann, G.:  
**Numerical Investigations on Local Degradation and Vertical Misalignments of Grouted Joints in Monopile Foundations**  
Twenty-third International Offshore and Polar Engineering Conference, June 30th–July 5th, Anchorage, Alaska, USA (2013)

- Schaumann, P.; Steppeler, S.:  
**Fatigue tests of axially loaded butt welds up to very high cycles**  
 5th Fatigue Design Conference,  
 November 27th-28th, Senlis (2013)
- Schaumann, P.; Raba, A.; Bechtel, A.:  
**Impact of Contact Interface Conditions on the Axial Load Bearing Capacity of Grouted Connections**  
 Proceedings of EWEA 2013,  
 February 4th- 7th 2013, Vienna, Austria  
 (2013)
- Schaumann, P., Raba, A.; Bechtel, A.:  
**Impact of Contact Interface Conditions on the Axial Load Bearing Capacity of Grouted Connections**  
 EWEA 2013, February 4th-7th, Vienna,  
 Austria. 2013
- Schmidt, B.; Hansen, M.:  
**Analyse mehrjähriger Messzeitreihen zur Ermittlung designrelevanter Lastparameter für Offshore-Windenergieanlagen**  
 DVW-Seminar "Zeitabhängige Messgrößen", Feb. 26th-27th 2014,  
 Hannover
- Schmidt, B.:  
**Windenergie in schwerer See**  
 Neue Energie (6), Wissenschaftlich betrachtet, pp. 56-57, (2014)
- Schmidt, M.; Mücke, T.; Milan, P.:  
**Windmodellierung für das Design von Windenergieanlagen in Taifun-gefährdeten Gebieten**  
 3. Fachtagung Energiemeteorologie,  
 Grainau, Germany,  
 June 4th-6th 2013
- Schmidt, M.; Tambke, J.; Steinfeld, G.; Heinemann, D.:  
**Ein verbesserter Korrekturalgorithmus für Ultraschalldaten**  
 Deutsch-Österreichisch-Schweizerische Meteorologentagung DACH 2013, Innsbruck, Austria,  
 September 2nd-6th 2013
- Schmidt, M., Tambke, J., Steinfeld, G., Heinemann, D.:  
**Conventional measurement data: good enough for offshore meteorology?**  
 EGU General Assembly 2014, Vienna, Austria,  
 April 27th-May 2nd 2014
- Schmohl, T.:  
**Entwicklung von Handhabungseinrichtungen für biegeweiche Materialien – Großflächiges preforming für die Rotorblattfertigung**  
 Kolloquium des Forschungsverbund Windenergie, Braunschweig,  
 Nov. 12th 2014
- Schmoor, K.A., Achmus, M.:  
**On the validation of reliability and partial safety factors for axially loaded piles in dense sand**  
 4th International Symposium on Geotechnical Safety and Risk (4th ISGSR),  
 Hong Kong, Dec. 4th-6th 2013
- Schneemann, J.; Trujillo, J. J.; Trabucchi, D.; Beck, H.; Unguran, R.; Voß, S.; Kühn, M.:  
**GW Wakes - Measuring wake effects in "alpha ventus" using a long range multi lidar**  
 FINO Conference, Kiel Presentation misc jjt/ Schneemann-2013
- Schneider, S.:  
**Strain rate dependency of concrete fatigue.**  
 In: Justnes, H. (Ed.): Proceedings of the 1st Concrete Innovation Conference (CIC) 2014, June 11th-14th 2014,  
 Oslo (Norwegen)
- Sonnenschein, M.; Tröschel, M.; Lünsdorf, O.:  
**Smart Grids for Optimised Utilisation of Renewable Energy Supply**  
 Environmental Informatics and Renewable Energies - 27th International Conference on Informatics for Environmental Protection, pp. 178-187 (2013)
- Schwarzer, C.:  
**Niedersachsen: Schlüsselland der Energiewende durch (Offshore-) Windenergie?**  
 Der Klimawandel in Niedersachsen und seine Folgen für Meer und Küste  
 Workshop der Evangelischen Akademie Loccum, Cuxhaven/Duhnen,  
 November 16th 2014
- Schwarzer, C.:  
**Qualifizierung für die Windenergie: Das Windstudium und das Offshore Windstudium**  
 22. Windenergietage 2014, Potsdam  
 November 12th 2014
- Schwarzer, C.:  
**Berufsbegleitende Studienangebote Windenergie**  
 9. Job- und Bildungsmesse,  
 Wilhelmshaven  
 November 5th 2014
- Schwarzer, C.:  
**Überblick über die Offshore-Windenergie**  
 Mitgliederversammlung der Raiffeisen-Volksbank, Varel-Rodenkirchen  
 Oktober 23rd 2014
- Schwarzer, C.:  
**Qualifizierung für die Erneuerbaren Energien am Beispiel Windenergie**  
 FORUM ERNEUERBARE ENERGIEN auf der HANNOVER MESSE 2014, Hannover  
 April 11th 2014
- Schwarzer, C.:  
**Weiterbildung in der Windenergiebranche**  
 22. Windenergietage 2013, Rheinsberg  
 November 14th 2013

- Späth, S., von Bremen, L., Junk, C.:  
**Ways to generate probabilistic wind power forecasts from ensemble weather forecasts**  
Proc. Of Wind Integration Workshop 2014, pp. 1-6, (2014)
- Späth, S.; von Bremen, L.; Junk, C.:  
**Verifikation bodennaher Windvorhersagen des COSMO-DE EPS für Anwendungen in der Windenergie**  
Deutsch-Österreichisch-Schweizerische Meteorologentagung DACH 2013, Innsbruck, Austria, September 2nd-6th 2013
- Späth, S., von Bremen, L., Junk, C., Heinemann, D.:  
**Probabilistic regional wind power forecasts based on calibrated Numerical Weather Forecast ensembles**  
EGU General Assembly 2014, Vienna, Austria, April 27th-May 2nd 2014
- Späth, S., von Bremen, L., Junk, C., Heinemann, D.:  
**Calibration of COSMO-DE EPS wind forecasts and their application to short-term wind power predictions**  
COSMO/CLM User Seminar 2014, Offenbach, Germany, March 17th-19th 2014
- Späth, S., von Bremen, L., Junk, C.:  
**Ways to generate probabilistic wind power forecasts from ensemble weather forecasts**  
Wind Integration Workshop 2014, Berlin, Germany, November 11th-13th 2014
- Steinfeld, G., Witha, B., Dörenkämper, M., Bromm, M., Vollmer, L., Heinemann, D.:  
**Analysis of wind turbine wakes and wind farm flows with the large-eddy simulation model PALM**  
Proceedings of Grand Renewable Energy 2014, pp. 1-4, (2014)
- Steinfeld, G., Witha, B., Dörenkämper, M., Vollmer, L., Wurps, H., Heinemann, D.:  
**Improvement of a wind farm parameterization for mesoscale models based on a parameter study with the large-eddy simulation model PALM**  
14th EMS Annual Meeting, Prague, Czech Republic, October 6th-10th 2014
- Steinfeld, G., Witha, B., Dörenkämper, M., Bromm, M., Vollmer, L., Heinemann, D.:  
**Analysis of wind turbine wakes and wind farm flows with the large-eddy simulation model PALM**  
Grand Renewable Energy 2014, Tokyo, Japan, July 27th-August 1st 2014
- Stoffels, N.; von Bremen, L.; Heinemann, D.:  
**Systematische Untersuchung zur Entstehung von Vergleichmäßigkeiten von Vorhersagefehlern bei der Windleistungsvorhersage**  
Deutsch-Österreichisch-Schweizerische Meteorologentagung DACH 2013, Innsbruck, Austria, September 2nd-6th 2013
- Tambke, J., Bye, J., A., T, Schmidt, M., Wolff, J.-O.:  
**Measuring and modelling the frictional velocity  $u^*$ , turbulence and heat fluxes above the North Sea**  
EGU General Assembly 2014, Vienna, Austria, April 27th-May 2nd 2014
- Thiemann, P.; Dollinger, C.:  
**Zerstörungsfreie und zuverlässige Detektion thermischer Schädigungen bei Schleifprozessen in Echtzeit**  
DFMRS-Windenergietagung 2013. Bremen, Nov. 7th 2013
- Thiemann, P.; Geilert, P.; Wagner, A.:  
**Schleifbrand – Ansätze zur Erkennung und Vermeidung beim Verzahnungsschleifen**  
In: 4. Kongress zur Getriebeproduktion, GETPRO, Würzburg, pp. 209-221. (2013)
- Trabucchi, D.; Beck, H.; Schneemann, J.; Trujillo, J. J.; Ungurán, R.; Voss, S.; Kühn, M.:  
**Offshore wind farm flow characteristics measured by a long range multi-lidar system: development and preliminary results**  
EWEA Offshore November Presentation misc jttl Trabucchi-2013
- Vera Tudela, L.; Kühn M.  
**Fatigue load monitoring of wind turbines in a wind farm based on standard signals**  
9th PhD EAWC Seminar on Wind Energy in Europe Gotland, 2013, Sweden
- Vollmer, L., Bromm, M., Steinfeld, G., Heinemann, D., Kühn, M.:  
**Wind turbine wake deflection in different atmospheric stratifications**  
14th EMS Annual Meeting, Prague, Czech Republic, October 6th-10th 2014
- von Bremen, L.:  
**Key drivers for improved short-term wind power forecasting over the last decade: a diagnosis**  
2nd International Conference Energy & Meteorology, Toulouse, France, June 25th-28th 2013
- von Bremen, L. :  
**Increased wind power forecast skill due to improved NWP in the last decade**  
EWEA Technology Workshop: Wind Power Forecasting, Rotterdam, The Netherlands, December 3rd-4th 2013
- von der Haar, C.:  
**Design Aspects of Concrete Towers for Wind Turbines.**  
In: International Seminar on Design of Wind Turbine Support Structures, Sept. 3rd.2014, Stellenbosch, Süd Afrika.

von Freyberg, A.; Stöbener, D.; Lübke, K.; Goch, G.:

**Flexible manufacturing of modified involute gears**

The proceedings of MTTRF 2013 Meeting, San Francisco, California, USA, pp. 143-160 (2013)

Winstroth, J.; Seume, J. R.:

**Wind Turbine Rotor Blade Monitoring Using Digital Image Correlation: Assessment on a Scaled Model**

32nd ASME Wind Energy Symposium, National Harbor, Maryland. (2014)

Winstroth, J.; Seume, J. R.:

**Wind Turbine Rotor Blade Monitoring Using Digital Image Correlation: 3d Simulation of the Experimental Setup**

EWEA 2014, Barcelona. (2014)

Winstroth, J.; Schön, L.; Ernst, B.; Seume, J. R.:

**Wind Turbine Rotor Blade Monitoring Using Digital Image Correlation: A Comparison to Aeroelastic Simulations of a Multi-Megawatt Wind Turbine**

Journal of Physics: Conference Series, p. 524, June. (2014)

Witha, B.; Steinfeld, G.;

Dörenkämper, M.; Heinemann, D.:

**Hochaufgelöste Nachlaufsimulationen mit dem LES-Modell PALM: Vergleich verschiedener Turbinenmodelle und Anwendung im Offshore-Windpark „EnBW Baltic 1“**

3. Fachtagung Energiemetereologie, Grainau, Germany, June 4th-6th 2013

Witha, B.; Steinfeld, G.;

Dörenkämper, M.; Heinemann, D.:

**Large-Eddy Simulationen des Nachlaufs von Windenergieanlagen: Vergleich verschiedener Turbinenmodelle und Anwendung im Offshore-Windpark „EnBW Baltic 1“**

Deutsch-Österreichisch-Schweizerische Meteorologentagung DACH 2013, Innsbruck, Austria, September 2nd-6th 2013

Witha, B., Steinfeld, G., Heinemann, D.:

**Large-eddy simulations of the internal boundary layer and wake flow within very large wind farms**

14th EMS Annual Meeting, Prague, Czech Republic, October 6th-10th 2014

Witha, B., Steinfeld, G., Heinemann, D.:

**Advanced turbine parameterizations in offshore LES wake simulations**

6. International Symposium on Computational Wind Engineering (CWE 2014), Hamburg, Germany, June 8th-12th 2014

Wolff, T.; Ernst, B.; Seume, J. R.:

**Aerodynamic behavior of an airfoil with morphing trailing edge for wind turbine applications**

J. Phys.: Conf. Ser. 524, 012018, DOI: 10.1088/1742-6596/524/1/012018. (2014)

Wolff, T.; Seume, J.R.:

**Airfoil with Morphing Trailing Edge for Load Reduction in Wind Turbines**

33rd Wind Energy Symposium, Kissimmee, FL/USA, DOI: 10.2514/6.2015-1662. (2015)

Wolff, T.; Seume, J. R.:

**Numerical investigation of an airfoil with morphing trailing edge for load reduction**

10th PhD Seminar on Wind Energy in Europe 2014, Orléans, France, Oct 28th-31th 2014

Wurps, H., Tambke, J., Steinfeld, G., von Bremen, L.:

**Evaluation of planetary boundary layer schemes in meso-scale simulations above the North and Baltic Sea**

EGU General Assembly 2014, Vienna, Austria, April 27th-May 2nd 2014

Public Lectures, Articles in  
Magazines and Other Publications

Barth, S.:

**Herausforderungen in der  
Windenergieforschung**

invited talk

Public lectures, Schlaues Haus,  
Oldenburg, Germany, Feb. 16th 2013

Barth, S.:

**Panel discussion "Energiewende in  
Europa und Niedersachsen"**

Osnabrück, Germany,  
May 30th 2013

Barth, S.:

**Herausforderungen in der  
Windenergieforschung**

invited talk, UGO-Forum,  
Wittmund, Germany,  
Aug. 27th 2013

Barth, S.:

**TV-Interview**

NDR Hallo Niedersachsen  
Sept. 5th 2013

Barth, S.:

**Herausforderungen in der  
Windenergieforschung**

Wirtschaft trifft Wissenschaft: IHK-Besuch  
Oldenburg, Germany, Nov. 7th 2013

Barth, S.:

**Moderation**

10th Anniversary Celebration ForWind  
Oldenburg  
Feb 18th 2014

Barth, S.:

**Das EEG – Bundestagsfraktion und  
Energiewende in Europa**

Panel discussion Rastede, Germany  
May 14th 2014

Barth, S.:

**TV-Interview**

NDR Bingo Umweltlotterie  
Aug. 8th 2014

Barth, S.:

**Herausforderungen in der Windenergie-  
forschung**

invited talk

Lions Club Nordenham / Elsfleth  
Elsfleth, Germany, Oct. 6th 2014

Barth, S.:

**Der Forschungsverbund Windenergie**

Preisverleihung Norddeutscher Wissen-  
schaftspreis 2014  
Hannover, Germany, 28.11.2014

Barth, S.:

**TV-Interview**

NDR Hallo Niedersachsen  
Nov. 28th 2014

Barth, S.:

**Herausforderungen in der  
Windenergieforschung**

IHK-Beirat Delmenhorst/Oldenburg-Land  
Wardenburg, Germany, Dec. 1st 2014

Dollinger, C.; Sorg, M.; Thiemann, P.:

**Aeroacoustic Optimization of Wind  
Turbine Airfoils by Combining  
Thermographic and Acoustic  
Measurement Data**

DEWI Magazin No. 43, Wilhelmshaven,  
2013, pp. 61-64

Franke, J.; Thoben, K.-D.:

**Binderapplikation für biegeweiche  
Materialien**

MM Maschinen Markt/CW Composites  
World, 1, pp. 15-17 (2014)

Hansen, M. et al.:

**Probabilistic Safety Assessment of  
Offshore Wind Turbines**

Annual Report 2013 in Project Safety  
Assessment of Offshore Wind Turbines,  
Hannover, Germany, (2014)

Hansen, M.; Schaumann, P.; Kelma, S.  
et al.:

**Foundation and Support Structure  
(WP 4)**

in Probabilistic Safety Assessment of  
Offshore Wind Turbines  
Annual Project Report PSA-OWEA 2012,  
pp. 19-26 (2013)

Hansen, M.:

**Offshore – Technisches Risiko.**

Neue Energie (5), Wissenschaftlich  
betrachtet pp., 46-47, (2014)

Ischtschuk, L.; Ohlendorf, J.-H.:

**Mapretec: a new production process  
for the wind energy sector**

JEC Composite Magazin, 90, pp. 30-32  
(2014)

Kühn, M.; Steinfeld, G., Cheng, P.-W.;  
Schaumann, P.; Neumann, T. (Ed.):

**Abschlussbericht des RAVE-Projekts  
» Verifikation von Offshore-  
Windenergieanlagen« (OWEA)**

Final Report of BMU Project OWEA,  
pp. 1-338, 2013

Kühn, M.; Trabucchi, D.:

**IEA Wind Task 32 – Lidar**

IEA Wind Annual Report 2013

Marx Gómez, J., Sonnenschein, M.,  
Vogel, U., Winter, A., Rapp, B., Giesen,  
N. (Eds.):

**Proceedings of the 28th  
Conference on Environmental Informa-  
tics – EnviroInfo 2014 – ICT for Energy  
Efficiency. BIS-Verlag, Oldenburg (2014)**

Marx, S.; von der Haar, C.:

**Stahlbeton- und Spannbeton-  
konstruktionen für Offshore  
Windenergieanlagen**

In: Design and Installation für Offshore-  
Windenergieanlagen und Konverterplatt-  
formen

arranged by ForWind Academy and Haus  
der Technik,  
Nov. 3rd-4th 2014, Hannover.

Marx, S.; von der Haar, C.; Schmidt, B.:

**Bauwerk Offshore Windenergieanlage  
– wie baut man das aus Beton?**

In: ForWind Vortragsreihe,  
Feb. 20th 2014, Oldenburg

Ohlendorf, J.-H.; Rolbiecki, M.; Schmohl,  
T.; Franke, J.; Thoben, K.-D.;

Ischtschuk, L.:

**Innovationen in der Handhabungs- und  
Textiltechnik zur Rotorblattfertigung**

Lightweight Design, 6, pp. 50-57. (2013)

Rolbiecki, M.; Ohlendorf, J.-H.; Decker, A.; Thoben, K.-D.; Ischtschuk, L.:

**Intelligente Materialbereitstellung zur automatisierten Herstellung textiler Preforms**

Lightweight Design, 7, pp. 42-49. (2014)

Rolfes, R.; Schaumann, P.; Gottschalk, M.; Vásquez-Rojas, A.; Collmann, M. et al.:

**Ganzheitliches Dimensionierungskonzept für OWEA-Tragstrukturen anhand von Messungen im Offshore-Testfeld alpa ventus**

BMU-Research Project GIGAWIND alpha ventus, Final Report, Shaker Verlag, ISBN 978-3-8440-1762-5 (2013)

Schaumann, P.; Collmann, M.; Konya, R.; Hassel T.; Bach, F.-W.; Deißer, T.A.; Priebe, S.:

**Ökologische und ökonomische Hochleistungsfügetechniken für Stahlrohtürme von Windenergieanlagen**

BMU-Research Project OPTIWELD, Final Report, Online Publication, <http://edok01.tib.uni-hannover.de/edoks/e01fb14/780376676.pdf> (2013)

Schmidt, B.:

**Windenergie in schwerer See. Neue Energie (6),**

Wissenschaftlich betrachtet, pp.56-57 (2014)

Schwarzer, C.; Kärn, M.:

**Weiterbildung für die Windbranche**

Berufsbegleitende Studienangebote qualifizieren für Fach- und Führungsaufgaben in der Windenergiebranche. Ingenieurspiegel 4 | 2013, pp. 66-67

Thiemann, P.; Dollinger, C.:

**Schleifbrand sicher detektieren**

Magazin für Oberflächentechnik 67, 2013, No. 7-8, pp. 26-28

Thiemann, P.; Ströbel, G.; Goch, G.:

**Mikromagnetische und photothermische Charakterisierung thermomechanischer Schädigungen**

tm – Technisches Messen 80, 2013, pp. 206-212

von Bremen, L.; Junk, C.:

**Impact of various ensemble configurations for wind power predictions**

Deliverable Dp-5.10 in EU Project SafeWind, pp. 1-17

von der Haar, C.:

**Design Aspects of Concrete Towers for Wind Turbines**

In: International Seminar on Design of Wind Turbine Support Structures, Sept. 3rd 2014, Stellenbosch, South Africa

**Lectures**

Achmus, M.; Schmoor, K.:

**Tragstrukturen von Offshore-Windenergieanlagen**

M.Sc.-Degree-Course "Structural Engineering"

Leibniz Universität Hannover  
Institut für Geotechnik (IGtH)  
Winter term 2014/2015

Achmus, M.; Lemke, K.:

**Grundbaukonstruktionen**

M.Sc.-Degree-Course "Structural Engineering" and "Water-, Environmental- and Coastal Engineering"

Leibniz Universität Hannover  
Institut für Geotechnik (IGtH)  
Summer term 2013

Balzani, C.; Kleineidam, P.; Reuter, A.:

**Planung und Errichtung von Windparks**

Leibniz Universität Hannover,  
Winter term 2012/2013 and 2013/2014

Bertsch, L.; Gardner, A. D.; Mulleners, K.; Richter, K.; Raffel, M.:

**Rotor Aerodynamics**

Institute of Turbomachinery and Fluid Dynamics, Leibniz Universität Hannover,  
Winter term 2013/14

Garbe, H.:

**Measurement Techniques for Signals and Systems**

Leibniz Universität Hannover,  
Summer term 2011/2012

Gomez, A. G.:

**Aerodynamics and Aeroelasticity of Wind Turbines**

Leibniz Universität Hannover,  
Winter term 2013/2014

Grießmann, T.:

**Schwingungsprobleme bei Bauwerken (lecture)**

Leibniz Universität Hannover,  
Institute of Structural Analysis,  
Winter term 2012/13

- Hahn, A.:  
**Transportation System Systems**  
Carl von Ossietzky Universität Oldenburg,  
Summer term 2011/2012
- Hansen, M.; Schmidt, B.; Piehler, J.:  
**Sonderkonstruktionen im Massivbau**  
Leibniz Universität Hannover,  
Winter term 2013/2014
- Hansen, M.; von der Haar, C.:  
**Sonderkonstruktionen im Massivbau**  
Leibniz Universität Hannover,  
Winter term 2014/2015
- Kühn, M.:  
**Mechanics**  
Carl von Ossietzky Universität Oldenburg,  
Institute of Physics  
Winter term 2012/2013
- Kühn, M.; Heinemann, D.; et. al.:  
**Introduction to Engineering Physics**  
Carl von Ossietzky Universität Oldenburg,  
Institute of Physics  
Winter term 2012/2013
- Kühn, M.; Poland, K.:  
**Finite Element Analysis**  
Carl von Ossietzky Universität Oldenburg,  
Institute of Physics  
Winter term 2012/2013
- Kühn, M.; Heinemann, D.:  
**Introduction to Renewable Energies**  
Carl von Ossietzky Universität Oldenburg,  
Institute of Physics  
Summer term 2013
- Kühn, M.; Schmidt, A.:  
**Wind Energy Utilisation**  
Carl von Ossietzky Universität Oldenburg,  
Institute of Physics  
Summer term 2013
- Kühn, M.:  
**Design of Wind Energy Systems**  
Carl von Ossietzky Universität Oldenburg,  
Institute of Physics  
Summer term 2013
- Kühn, M.; Heinemann, D.; Peinke, J.;  
Schmidt, A.; Trabucchi, D.; Späth, S.;  
Dörenkämper, M.; Hölling, M.;  
Wächter, M.:  
**Wind Physics Measurement Project**  
Carl von Ossietzky Universität Oldenburg,  
Institute of Physics  
Summer term 2013
- Kühn, M.; Heinemann, D.; Peinke, J.:  
**Arbeitsgruppenseminar Windenergie  
Themen aktueller Forschung**  
Carl von Ossietzky Universität Oldenburg,  
Institute of Physics  
Summer term 2013
- Kühn, M.:  
**Mechanics**  
Carl von Ossietzky Universität Oldenburg,  
Institute of Physics  
Winter term 2013/2014
- Kühn, M.; Heinemann, D.; et. al.:  
**Introduction to Engineering Physics**  
Carl von Ossietzky Universität Oldenburg,  
Institute of Physics  
Winter term 2013/2014
- Kühn, M.; Perrone, F.:  
**Wind Turbine Design Project**  
Carl von Ossietzky Universität Oldenburg,  
Institute of Physics  
Winter term 2013/2014
- Kühn, M.; Heinemann, D.; Peinke, J.:  
**Arbeitsgruppenseminar Windenergie  
Themen aktueller Forschung**  
Carl von Ossietzky Universität Oldenburg,  
Institute of Physics  
Winter term 2013/2014
- Kuhnle, B.; Kühn, M.:  
**Aeroelastic Simulation of Wind  
Turbines**  
Carl von Ossietzky Universität Oldenburg,  
Institute of Physics  
Summer term 2013
- Lochte-Holtgreven, S.:  
**Tragsicherheit im Stahlbau (Structural  
safety in steel constructions)**  
Leibniz Universität Hannover,  
Winter term 2013/2014
- Poland, K.:  
**Basic Laboratory I**  
Carl von Ossietzky Universität Oldenburg,  
Institute of Physics  
Winter term 2012/2013
- Poland, K.:  
**Basic Laboratory I**  
Carl von Ossietzky Universität Oldenburg,  
Institute of Physics  
Winter term 2013/2014
- Raasch, S.:  
**Turbulenz II**  
Leibniz Universität Hannover  
Winter term 2014/2015
- Raasch, S.:  
**Introduction to Large-Eddy Simulation  
Models**  
Leibniz Universität Hannover,  
Summer term 2015
- Reuter, A.; Balzani, C.:  
**Windenergie-technik I**  
Leibniz Universität Hannover,  
Winter term 2012/2013 and 2013/2014
- Reuter, A.; Balzani, C.:  
**Windenergie-technik II**  
Leibniz Universität Hannover,  
Summer term 2013
- Reuter, R.:  
**Optik der Atmosphäre und des Ozeans**  
Carl von Ossietzky Universität Oldenburg,  
Institute of Physics  
Summer term 2013
- Reuter, R.:  
**Experimentalphysik II: Elektrodynamik  
und Optik**  
Carl von Ossietzky Universität Oldenburg,  
Institute of Physics  
Summer term 2013
- Reuter, R.:  
**Experimentalphysik IV: Thermodyna-  
mik und Statistik**  
Carl von Ossietzky Universität Oldenburg,  
Institute of Physics  
Summer term 2014



- Reuter, R.:  
**Physik für Studierende der Chemie und Umweltwissenschaften**  
Carl von Ossietzky Universität Oldenburg, Institute of Physics  
Winter term 2014/2015, summer term 2015
- Rolfes, R.; Reinoso, J.:  
**Faserverbund-Leichtbaustrukturen** (lecture),  
Leibniz Universität Hannover, Institute of Structural Analysis,  
Winter term 2012/13
- Rolfes, R.; Schaumann, P.; Achmus, M.:  
**Tragstrukturen von Offshore-Windenergieanlagen** (lecture)  
Gottfried Wilhelm Leibniz Universität Hannover, Institute of Structural Analysis,  
Winter term 2012/13
- Schaumann, P.:  
**Tragstrukturen von Offshore-Windenergieanlagen (Support Structures of Offshore Wind Turbines)**  
Leibniz Universität Hannover,  
Winter term 2013/2014
- Seume, J.; Rockendorf, G.; Gómez, A.:  
**Renewable Energies**  
Institute of Turbomachinery and Fluid Dynamics, Leibniz Universität Hannover,  
Summer term 2013
- Sorg, M.; Westerkamp, J. F.:  
**Triebstrang einer Windenergieanlage**  
Universität Bremen, Bremen Institute for Metrology, Automation and Quality Science, Winter term 2012/2013, Summer term 2013
- Sorg, M.; Schröter, O.:  
**Aufbau eines Versuchsstands zur Durchführung von Untersuchungen an Rotorblättern mithilfe der IR-Thermografie**  
Universität Bremen, Bremen Institute for Metrology, Automation and Quality Science, Winter term 2013/2014
- Sorg, M.; Behrendt, W.:  
**Versuchsstand aktive IR-Thermografie (Infrarotarray)**  
Universität Bremen, Bremen Institute for Metrology, Automation and Quality Science, Winter term 2013/2014
- Thoben, K.-D.:  
**Produktdesign & Gestaltung – K-Lehre 1**  
Universität Bremen, Institute for Integrated Product Development (BIK)  
Winter term 2012/13 & Winter term 2013/14
- Thoben, K.-D.:  
**Anwendung eines 3D-CAD-Systems**  
Universität Bremen, Institute for Integrated Product Development (BIK)  
Winter term 2012/13 & Winter term 2013/14
- Thoben, K.-D.:  
**Produktdesign & Gestaltung – K-Lehre 2**  
Universität Bremen, Institute for Integrated Product Development (BIK)  
Sommer term 2013 & Sommer term 2014
- Thoben, K.-D.:  
**Konstruktionslehre – K-Lehre 3**  
Universität Bremen, Institute for Integrated Product Development (BIK)  
(BIK)  
Sommer term 2013 & Sommer term 2014
- Thoben, K.-D.:  
**Anwendung und Vergleich von Kreativitätstechniken**  
Universität Bremen, Institute for Integrated Product Development (BIK)  
Sommer term 2013 & Sommer term 2014
- Thoben, K.-D.:  
**Produktionssystematik**  
Universität Bremen, Institute for Integrated Product Development (BIK)  
Sommer term 2013 & Sommer term 2014
- Thoben, K.-D.:  
**CAD – Management und virtuelle Produktentwicklung**  
Universität Bremen, Institute for Integrated Product Development (BIK)  
Sommer term 2013 & Sommer term 2014
- Thoben, K.-D.:  
**Einführung in die Konstruktionsmethodik**  
Universität Bremen, Institute for Integrated Product Development (BIK)  
Sommer term 2012 & Sommer term 2014
- Thoben, K.-D.:  
**Anwendung von Konstruktionsmethoden**  
Universität Bremen, Institute for Integrated Product Development (BIK)  
Sommer term 2012 & Sommer term 2014
- von Bremen, L., Steinfeld, G., Heinemann, D.:  
**Seminar zu aktuellen Forschungsthemen in der Wind-Energiemeteorologie**  
Carl von Ossietzky Universität Oldenburg, Institute of Physics,  
Summer Term 2013  
Winter Term 2013/2014,  
Summer Term 2014,  
Winter Term 2014/2015
- von Freyberg, A.:  
**Geometrische Messtechnik mit Labor**  
Universität Bremen, Bremen Institute for Metrology, Automation and Quality Science,  
Winter term 2013
- Weber, F.:  
**Concurrent Engineering**  
Universität Bremen, Institute for Integrated Product Development (BIK)  
Sommer term 2013 & Sommer term 2014
- Westerkamp, J. F.:  
**Entwurf und Aufbau eines optischen Sensorsystems**  
Universität Bremen, Bremen Institute for Metrology, Automation and Quality Science,  
Winter term 2012/2013,  
Summer term 2013

## PhD Theses

Decker, A.:

**Mono-Material-Strukturen in der autonomen Anwendung zur Erhöhung der Recycelfähigkeit**

PhD Thesis,

University of Bremen (2013)

Heßling, C.:

**Entwicklung selbstoptimierender Prozesse in der NC-Verfahrenskette**

PhD Thesis,

University of Bremen (2013)

Kruse, D.:

**Photothermische Randzonenuntersuchungen an wärmebehandelten Stählen und Objekten mit thermischer Schädigung**

PhD Thesis,

Universität Bremen (2013)

Lochte-Holtgreven, S.:

**Zum Trag- und Ermüdungsverhalten biegebeanspruchter Grouted Joints in Offshore-Windenergieanlagen**

PhD Thesis,

Leibniz Universität Hannover (2013)

Shaker-Verlag Aachen, ISBN 978-3-8440-1987-2

## Diploma, Master, Bachelor, and other Theses

Amini, G.:

**Ermittlung der Tragfähigkeit von Pfählen anhand dynamischer Probelastung**

Project-Thesis,

Leibniz Universität Hannover (2013)

Attia, Y.:

**Numerische Untersuchungen von Pile-Raft-Gründungen für Offshore Windkraftanlagen**

Bachelor-Thesis,

Leibniz Universität Hannover (2013)

Aydin, N.:

**Modellierung von Logistikabläufen**

Bachelor Thesis,

Carl von Ossietzky Universität Oldenburg (2013)

Bayrak, M. L.:

**Optimierung eines optischen Erbium-dotierten Faserverstärkers für die Lidar-Anwendung in der Mess- und Regelungstechnik von Windkraftanlagen**

Master thesis,

Carl von Ossietzky University Oldenburg (2014)

Beckmann, S.:

**Alternative Messmethoden zur Bestimmung von Seegangseinwirkungen**

Project Thesis,

Leibniz Universität Hannover (2014)

Beckröge, S.; Plate, T.:

**Entwicklung eines Handhabungskonzeptes zur automatisierten Ablage textiler Bahnwaren in eine Rotorblattform**

Master Project, University of Bremen

(2014)

- Bender, T.:  
**Dynamische Lastganganalyse für eine Produktions- und Energieoptimierung beim Einsatz energieintensiver Produktionsanlagen und -maschinen gemäß vertraglicher Beschränkungen der Strombelieferung**  
Master Thesis,  
Carl von Ossietzky Universität Oldenburg (2013)
- Berger, M.:  
**Installationsvorgang von Suction-Bucket-Gründungen**  
Diploma Thesis,  
Leibniz Universität Hannover (2013)
- Berkemeyer, F.:  
**Messtechnische Erfassung der Einbaulage von meteorologischen Sensoren**  
Bachelor Thesis,  
Universität Bremen (2013)
- Best, Chr.:  
**Erhöhung der Anpassbarkeit eines Softwaresystems – Konzept zum systematischen Anpassen an kundenindividuelle Anforderungen**  
Bachelor Thesis,  
Carl von Ossietzky Universität Oldenburg (2013)
- Bloh, M.:  
**Optimization of the design of wind turbine rotor blades using the "Cuckoo Search" algorithm**  
Diploma Thesis,  
Leibniz Universität Hannover (2011)
- Blohm, K., Vorlauf S.:  
**Entwicklung eines Simulationswerkzeuges zur verteilten Agentensimulation mit unterschiedlichen Synchronisationsverfahren**  
Master Thesis,  
Carl von Ossietzky Universität Oldenburg (2013)
- Bode, M.:  
**Korrelation von Wind- und Seegangsbedingungen am Standort FINO 1**  
Diploma Thesis  
Leibniz Universität Hannover (2013)
- Bogdanski, St.:  
**Konzeption und Implementierung eines Schedulers für Delivery-Orders in Intralogistik-Systemen**  
Master Thesis,  
Carl von Ossietzky Universität Oldenburg (2013)
- Böske, L.:  
**Representing mesoscale processes in large-eddy simulations of the atmospheric boundary layer by means of larger scale forcing**  
Master Thesis,  
Leibniz Universität Hannover (2015)
- Chamoun, M.; Kantner, T.;  
Mohammad, M.:  
**Einbringung, Erfassung und Auswertung von Materialfehlern in Preforms**  
Master Project, University of Bremen (2013)
- Cordes, M.:  
**Intelligentes Management elektromobiler Flotten durch V2 G**  
Bachelor Thesis,  
Carl von Ossietzky Universität Oldenburg (2013)
- Denker, Chr.:  
**Ein dezentrales Agentensystem zur Begleitung und Steuerung des Materialflusses**  
Master Thesis  
Carl von Ossietzky Universität Oldenburg (2013)
- Diederley, J.:  
**Numerische Schädigungsuntersuchung an Spannbetontürmen für Windenergieanlagen infolge Ermüdung**  
Diploma Thesis,  
Leibniz Universität Hannover (2013)
- Dölger, Chr.:  
**Beschreibung eines Benchmarks für reaktives Planen mit Bewertungsfunktion**  
Individuelles Projekt  
Carl von Ossietzky Universität Oldenburg (2013)
- Dörgeloh, T.:  
**Optimierung der flexiblen Fertigung modifizierter Zylinderräder mit einem 5-Achs-Bearbeitungszentrum**  
Bachelor Thesis,  
Universität Bremen (2013)
- Eilers, B.:  
**Inbetriebnahme und Regelung eines selbstgeführten Wechselrichters zur aktiven Oberschwingungskompensation**  
Diplomarbeit,  
Universität Bremen (2013)
- El Asmar, A.:  
**Berechnungen zu Tragfähigkeit und Tragverhalten vertikal belasteter Pfähle**  
Bachelor-Thesis,  
Leibniz Universität Hannover (2013)
- Espenhahn, B.:  
**Bestimmung des Schwebstoffgehalts von Wasserproben mit Hilfe eines multispektralen Transmissometers**  
Bachelor thesis,  
Carl von Ossietzky University Oldenburg (2014)
- Esquembre Sáez, P.:  
**Influence of environmental effects on the uncertainty of a large coordinate measuring machine**  
Bachelor Thesis,  
Universität Bremen (2013)
- Ewert, C.:  
**Rechtliche Rahmenbedingungen bei der Installation von Offshore-Windenergieanlagen**  
Project Thesis,  
Leibniz Universität Hannover (2013)
- Fahrenbach, Y.:  
**Untersuchungen zu Stahlrohrrippenpfählen für OWEA**  
Diploma Thesis,  
Leibniz Universität Hannover (2013)

- Fauteck, M.:  
**Inbetriebnahme eines Asynchronmotors mit Ansteuerung über LabVIEW und Nachbildung einer Windturbine**  
Studienarbeit,  
Universität Bremen (2013)
- Fayed, S.:  
**Optimization of wind estimation based on coherent lidar data acquisition**  
Master thesis,  
Carl von Ossietzky University Oldenburg (2014)
- Fereydunpur, A., & Syedykh, D.:  
**Simulation der Eindringung der Hubbeine von Jackup-Schiffen im Offshore-Einsatz unter Anwendung numerischer Berechnungsmethoden**  
Bachelor-Thesis,  
Leibniz Universität Hannover (2013)
- Fiedel, M.:  
**Flutter Analysis of Wind Turbine Rotor Blades**  
Project Thesis,  
Leibniz Universität Hannover (2013)
- Fuchs, J.:  
**Theoretische und numerische Untersuchungen zum Einfluss der Kerbwirkung auf die Ermüdungsfestigkeit von Schweißverbindungen**  
Bachelor Thesis,  
Leibniz Universität Hannover (2013)
- Gäding, U.:  
**Strömungsnetzrechnungen für Suction-Bucket-Installationen**  
Project-Thesis,  
Leibniz Universität Hannover (2013)
- Gerdes, A.:  
**Optimierung eines elektrischen Drehaktuators für Anwendungen in der Unterwasserrobotik**  
Bachelor Thesis, University of Bremen (2014)
- Gerendt, C.:  
**Numerische Simulation von Walzeigenspannungen**  
Project Thesis,  
Leibniz Universität Hannover (2013)
- Gerlach, T.:  
**Gründung von Onshore-Windenergieanlagen**  
Seminar Thesis,  
Leibniz Universität Hannover (2013)
- Gerlach, T.:  
**Modellierung und rechnerische Erfassung von Wellen auf See**  
Seminar Thesis,  
Leibniz Universität Hannover (2013)
- Gharbaoui, J.; Miesner, E.; Richrath, M.:  
**Experimentelle Untersuchung von Handhabungseffekten in der Prozesskette zur Herstellung von textilen Performs**  
Master Project, University of Bremen (2014)
- Gratza, P.:  
**Ermüdungsuntersuchungen an einem Schwerkraftfundament einer Offshore-Windenergieanlage**  
Bachelor Thesis  
Leibniz Universität Hannover (2014)
- Grünefeld, M.:  
**Entwicklung einer Regelung eines für verschiedene Textilizuschnittgeometrien adaptiven Wickspeichers in der automatisierten Rotorblattproduktion**  
Master Thesis, University of Bremen (2013)
- Grundmeier, N.:  
**Konzeption und Implementation eines Simulationstools zur Planung von Servicearbeiten in Offshore Windparks**  
Master Thesis  
Carl von Ossietzky Universität Oldenburg (2013)
- Hachem, A.:  
**Berechnung zum Tragverhalten horizontal belasteter Pfähle**  
Bachelor-Thesis,  
Leibniz Universität Hannover (2013)
- Held D.:  
**Bewertung des Dynamic Wake Meandering Modells mit LiDAR-Messdaten aus dem Offshore-Windpark EnBW Baltic 1**  
Bachelor thesis,  
Carl von Ossietzky University Oldenburg (2013)
- Hellfeldt, S.:  
**Endbearbeitung von Ringflanschverbindungen in Gründungsstrukturen von OWEA**  
Project Thesis,  
Leibniz Universität Hannover (2013)
- Henneberg, J.:  
**Anwendungsgrenzen der Balkentheorie und parametrisierter Berechnungsansätze zur Beurteilung der Ermüdungsfestigkeit von Tragstrukturen für OWEA**  
Bachelor Thesis,  
Leibniz Universität Hannover (2013)
- Herthum, H.:  
**Entwicklung einer Messboje für Temperatur- und Druckmessungen in Offshore-Windparks**  
Bachelor thesis,  
Carl von Ossietzky University Oldenburg (2014)
- Hinrichs, Chr.:  
**EA-Modellierungsmöglichkeiten für Cloud-Services-Integration**  
Diploma Thesis  
Carl von Ossietzky Universität Oldenburg (2013)
- Hoppe, O.:  
**Einsatzmöglichkeiten von Bildverarbeitungsmethoden in der Werkstoffprüfung und zur Prüfstandssteuerung**  
Bachelor Thesis,  
Universität Bremen (2013)
- Hu, S.:  
**Steuerung und Regelung einer 7,5-MW-Windturbine**  
Master's Thesis,  
Leibniz Universität Hannover (2013)

- Hu, S.:  
**Modellierung und Simulation von Flugwindenergiesystemen**  
Project Thesis,  
Leibniz Universität Hannover (2013)
- Hudarew, R.:  
**Berechnungen zum Tragverhalten horizontal belasteter Pfähle**  
Project-Thesis,  
Leibniz Universität Hannover (2013)
- Jankowski, S.:  
**Validierung des Farm Layout Programms (FLaP) durch Analyse der Windparkeffekte im Offshore-Windpark EnBW Baltic 1**  
Diploma Thesis,  
Technische Universität Hamburg-Harburg (2013)
- Kahleis, E. S.:  
**Axiale Tragfähigkeit von Rammpfählen in Kreide**  
Project-Thesis,  
Leibniz Universität Hannover (2013)
- Kahms, C.:  
**Entwicklung einer Methode zur Kostenprognose intelligenter Rotorblätter von Windenergieanlagen für die frühe Entwicklungsphase**  
Project Thesis,  
Leibniz Universität Hannover (2013)
- Kerßen, J.:  
**Statische und konstruktive Bearbeitung einer Suction-Bucket Gründung aus Beton für Offshore-Windenergieanlagen**  
Master Thesis,  
Leibniz Universität Hannover (2013)
- Kim, H.:  
**Behandlung von Störungen in intermodalen maritimen Supply Chains**  
Diploma Thesis  
Carl von Ossietzky Universität Oldenburg (2013)
- Klass, A.:  
**Konzipierung eines Handhabungseffektors für die Ablage von Glasfasergelgen in eine Rotorblatt-Hauptform**  
Master Thesis, University of Bremen (2014)
- Klein, F.:  
**Erstellung eines Simulations Optimierungstools**  
Bachelor Thesis  
Carl von Ossietzky Universität Oldenburg (2013)
- Kleinfeldt, H. U.:  
**Ausarbeitung konzeptioneller und normativer Rahmenbedingungen von Suction Buckets in Betonbauweise**  
Master Thesis,  
Leibniz Universität Hannover (2014)
- Könecke, N.:  
**Bestimmung der Sensitivität von statistischen Extrapolationsverfahren für die Ermittlung von Extremlastungen von OWEA**  
Bachelor Thesis, Institute of Turbomachinery and Fluid Dynamics,  
Leibniz Universität Hannover (2013)
- Krallmann, J.:  
**Einfluss des Temperaturfelds beim Schweißen mit dem Elektronenstrahl an der Atmosphäre auf die mechanisch-technologischen Eigenschaften der Schweißverbindung**  
Bachelor Thesis,  
Leibniz Universität Hannover (2013)
- Kublanck, D.:  
**Automatisierungspotenzial in der Produktion von Faser-Kunststoff-Verbunden**  
Master Thesis, University of Bremen (2014)
- Kuhlemann, R.:  
**Untersuchung zum Einfluss turbulenter Windkanalströmungen auf das Kalibrierergebnis von Schalensternanemometer**  
Master Thesis,  
Universität Bremen (2013)
- Lohbeck U.:  
**Vergleich von ingenieurwissenschaftlichen Nachlaufmodellen mit Long-Range Lidarmessungen**  
Master thesis,  
Carl von Ossietzky University Oldenburg (2013)
- Luna, R.:  
**Numerische Untersuchungen zum Tragverhalten von kleinmaßstäblichen Grout-Verbindungen unter statischer Belastung**  
Master Thesis,  
Leibniz Universität Hannover (2013)
- Malert St.:  
**Analyse und Bewertung von Offshore-konfigurationen der Hafenlandschaft in der Deutschen Bucht**  
Bachelor Thesis  
Carl von Ossietzky Universität Oldenburg (2013)
- Martin, C.:  
**Implementierung eines selbstorganisierten Verfahrens zur optimierenden Positionsbestimmung von Windenergieanlagen in beliebig geformten Gebieten**  
BSc Thesis,  
University of Oldenburg (2013)
- Mücke, F.:  
**Foroptimierung des Transition Piece von Jackets für Offshore-Windenergieanlagen**  
Master Thesis,  
Leibniz Universität Hannover (2013)
- Muric, I.:  
**Modellierung von Logistikabläufen**  
Bachelor Thesis  
Carl von Ossietzky Universität Oldenburg (2013)
- Mussnug, S.:  
**Lifetime Extension of Wind Turbines**  
Master's Thesis,  
Leibniz Universität Hannover (2013)

- Mrukwa, A.:  
**Bewertung der Qualität von Strukturbauteilen aus Organoblechen**  
Master Thesis, University of Bremen (2014)
- Osmers, J. H.:  
**Aeroakustische Untersuchung ausgewählter Rotorblattsegmente einer Windenergieanlage mit OpenFOAM**  
Master Thesis, Universität Bremen (2013)
- Osterndorf, M. S.:  
**Vergleich des statischen und dynamischen Verhaltens einer Jacket-Gründungsstruktur unter Wellenbeanspruchung**  
Project Thesis, Leibniz Universität Hannover (2013)
- Pätzold, L.:  
**Modellentwicklung torsionsbeanspruchter Turmquerschnitte**  
Diploma Thesis, Leibniz Universität Hannover (2014)
- Radulovic, L.:  
**Influence of advanced load simulation models on fatigue design of jackets for offshore wind turbines**  
Master Thesis, Leibniz Universität Hannover (2013)
- Reinhard, B.:  
**Konstruktiver Entwurf eines Robotermoduls zur automatisierten Handhabung von flächigen Hochleistungstextilien in mehrfach gekrümmten Formwerkzeugen**  
Master Thesis, University of Bremen (2013)
- Reinke, S.:  
**Entwurf und prototypische Implementierung einer mobilen Client-Applikation für einen Cloud-Dienst zur Ablage von Multimediainhalten**  
Bachelor Thesis, Carl von Ossietzky Universität Oldenburg (2013)
- Renner, B.:  
**Zum Ermüdungsverhalten von hybriden Verbindungen bei aufgelösten Unterstrukturen von offshore-Windenergieanlagen**  
Bachelor Thesis, Leibniz Universität Hannover (2013)
- Richrath, M.:  
**Entwicklung eines parametrisierten CAD-Modells für Rotorblätter von Windkraftanlagen**  
Bachelor Thesis, University of Bremen (2013)
- Ritz, A.:  
**Wissenschaftliche Vorteile durch Smart Changing**  
Individuelles Projekt, Carl von Ossietzky Universität Oldenburg (2013)
- Sartison, M.:  
**Untersuchung von Multiagentenplattformen in Hinblick auf die Integration holonischer Ansätze**  
Bachelor Thesis, Carl von Ossietzky Universität Oldenburg (2013)
- Schansker, T.:  
**Inbetriebnahme und Regelung eines Netzemulators auf Basis eines elektrisch erregten Synchrongenerators**  
Diplomarbeit, Universität Bremen (2013)
- Schmidt, J.:  
**Analyse und Optimierung der Sendempfangsoptik eines Doppler-Wind-Lidars**  
Diploma thesis, Carl von Ossietzky University Oldenburg (2013)
- Scholl, A.:  
**Einfluss von Produktionsfehlern auf das Versagen von Rotorblättern**  
Master Thesis, University of Bremen (2014)
- Scholz, J.:  
**Anforderungsanalyse für roboterassistiertes Orbitalfräsen von Faserverbundwerkstoffen**  
Bachelor Thesis, University of Bremen (2013)
- Schroedter, S.:  
**Vergleich von dynamischem und statistischem Downscaling zur Generierung von Windeinspeiszeitreihen**  
Bachelor Thesis in Engineering Physics, Carl von Ossietzky Universität (2014)
- Schütze, E.:  
**Studie zur Verallgemeinerung der Proportionalitätsmethode für die Schadensfrüherkennung an Rotorblättern von Windenergieanlage**  
Bachelor Thesis, Leibniz Universität Hannover (2013)
- Schulz, T.:  
**Dimensionierung des Lochbildes eines Düsenrohres unter Berücksichtigung von Strömungsverlusten**  
Bachelor Thesis, Leibniz Universität Hannover (2013)
- Schwarz, Chr.:  
**Simulationsbasierte Optimierung der Vorgänge auf einem Verladehof**  
Bachelor Thesis, Carl von Ossietzky Universität Oldenburg (2013)
- Seifert J. K.:  
**Characterisation of near wake dynamics with nacelle based full field lidar measurements of offshore wind turbines**  
Bachelor thesis, Carl von Ossietzky University Oldenburg (2013)
- Sextroh, C.:  
**Konzeptentwicklung einer Handhabungseinheit zur kontinuierlichen Ablage technischer Textilien in eine Rotorblatt-Hauptform**  
Master Thesis, University of Bremen (2014)

- Shrestha, B.:  
**Influence of different wind turbulence models on offshore wind turbine loads**  
Master thesis,  
Carl von Ossietzky University Oldenburg  
(2013)
- Siltan M.:  
**Impact of Wind Turbine Generator Systems on Electromagnetic Transients of Electrical Networks during Fault Occurrence – Relevant to Grid Integration**  
Master thesis,  
Carl von Ossietzky University Oldenburg  
(2013)
- Smith, P.:  
**Anforderungen von kleinen und mittleren Unternehmen an Cloud Computing**  
Master Thesis  
Carl von Ossietzky Universität Oldenburg  
(2013)
- Spengler, S.:  
**Anforderungen an die Architektur Cloud-basierter Softwaresysteme**  
Bachelor Thesis  
Carl von Ossietzky Universität Oldenburg  
(2013)
- Spiegel, C.:  
**Bestimmung der Ausfallwahrscheinlichkeit von Rotorblättern mittels FORM und SORM**  
Master Thesis, Institute of Turbomachinery and Fluid Dynamics, Leibniz Universität Hannover (2013)
- Spohn, C.:  
**Untersuchungen zum Tragverhalten von Suction-Bucket-Gründungen**  
Diploma Thesis,  
Leibniz Universität Hannover (2013)
- Starke, D.:  
**Analyse des Bedarfes von Hilfs- und Verbrauchsstoffen im Produktionsprozess von Rotorblättern für Windkraftanlagen**  
Master Thesis, University of Bremen  
(2013)
- Steinmeyer, F.:  
**Prozessoptimierung im Condition-Monitoring durch den Einsatz der Touchtechnologie**  
Master Thesis  
Carl von Ossietzky Universität Oldenburg  
(2013)
- Stelljes, P.:  
**Untersuchung der Nachhaltigkeit von Tragstrukturelementen für Windenergieanlagen**  
Bachelor Thesis,  
Leibniz Universität Hannover (2013)
- Tiedemann, R.:  
**SPS gestützte Zustandsanalyse eines klimatisierten Messlabors**  
Bachelor Thesis,  
Universität Bremen (2013)
- Viebranz, C.:  
**Leistungskurvenbestimmung von Windenergieanlagen mittels numerischer Strömungssimulationen**  
Diploma Thesis, Institute of Turbomachinery and Fluid Dynamics, Leibniz Universität Hannover (2013)
- Voss S.:  
**Turbulenzeigenschaften gemessen mit Doppler Puls Lidar**  
Master thesis,  
Carl von Ossietzky University Oldenburg  
(2013)
- Wagenfeld, B.:  
**Erstellung von Visualisierungs-Plugins für auf JASON basierende Verkehrssimulation**  
Master Thesis  
Carl von Ossietzky Universität Oldenburg  
(2013)
- Weber, S.:  
**Untersuchungen zum progressiven Rammversagen bei offenen Stahlrohr-rampfpfählen**  
Diploma Thesis,  
(2013)
- Wedel, F.:  
**Numerische Untersuchungen zum Einfluss geometrischer Imperfektionen in Grout-Verbindungen bei Offshore-Windenergieanlagen**  
Bachelor Thesis,  
Leibniz Universität Hannover (2013)
- Weisser, S.:  
**Theorie und Anwendung von WindPRO/WASP anhand eines Beispiel-Windparks**  
Project Thesis,  
Leibniz Universität Hannover (2013)
- Wilken, M.:  
**Entwicklungsprozessanalyse anhand von Änderungsdaten**  
Bachelor Thesis  
Carl von Ossietzky Universität Oldenburg  
(2013)
- Wohlfromm, L.:  
**Konstruktiver Entwurf einer Vorrichtung zur Vermessung der Schneidegeometrie eines Ultraschall-schneidekopfes für Hochleistungstextilien**  
Bachelor Thesis, University of Bremen  
(2014)
- Wojahn, E.:  
**Konzept zur Generierung von Observer-Pattern für eine 3D-Simulation zur Visualisierung/Überwachung von Systemzuständen**  
Bachelor Thesis  
Carl von Ossietzky Universität Oldenburg  
(2013)
- Wübbeling, Chr.:  
**Evaluation und Prototypische Implementation eines Cloud-Dienstes zur Ablage von Multimediainhalten**  
Master Thesis  
Carl von Ossietzky Universität Oldenburg  
(2013)

## List of ForWind Staff Members

**Abdel-Rahman, Khalid, Dr.-Ing. M.Sc.**  
Institute for Geotechnical Engineering  
+49 511 762 2273  
khalid@igth.uni-hannover.de

**Achmus, Martin, Univ.-Prof. Dr.-Ing.**  
Institute for Geotechnical Engineering  
+49 511 762 4155  
achmus@igth.uni-hannover.de

**Albensoeder, Stefan, Dr.**  
Institute of Physics,  
AG Energy Meteorology  
+49 441 798 5075  
stefan.albensoeder@forwind.de

**Albiker, Johannes, Dipl.-Ing.**  
Institute for Geotechnical Engineering  
+49 511 762 3529  
achmus@igth.uni-hannover.de

**Ambroise, Hugues, M.Sc.**  
Institute of Physics,  
AG Energy Meteorology  
+49 441 798 5078  
ambroise.hugues@forwind.de

**Bätge, Moritz, M.Sc.**  
Institute of Wind Energy Systems  
+49 471 14290 327  
moritz.baetge@iwes.uni-hannover.de

**Balzani, Claudio, Dr.-Ing.**  
Institute of Wind Energy Systems  
+49 511 762 5612  
claudio.balzani@iwes.uni-hannover.de

**Barth, Stephan, Dr.**  
ForWind Head Office  
+49 441 798 5091  
stephan.barth@forwind.de

**Bastine, David**  
Institute of Physics,  
AG Turbulence, Wind  
Energy and Stochastics – TWIST  
+49 441 798 5054  
david.bastine@uni-oldenburg.de

**Battermann, Dagmar**  
ForWind Head Office  
+49 441 798 5060  
dagmar.battermann@forwind.de

**Bechtel, Anne, Dipl.-Ing.**  
Institute for Steel Construction  
+49 511 762 2492  
bechtel@stahl.uni-hannover.de

**Beck, Hauke, M.Sc.**  
Institute of Physics,  
AG Wind Energy Systems – WE-Sys  
+49 441 798 5064  
hauke.beck@forwind.de

**Behrendt, Werner, Dipl.-Ing.**  
Bremen Institute for Metrology,  
Automation and Quality Science (BIMAQ)  
+49 0421 218 64636  
wb@bimaq.de

**Berthold, Tim, M.Sc.**  
Institute for Risk and Reliability – IRZ  
+49 511 762 17883  
berthold@irz.uni-hannover.de

**Betcke, Jethro, M.Sc.**  
Institute of Physics,  
AG Energy Meteorology  
+49 441 798 3927  
jethro.betcke@forwind.de

**Bitter, Martin, Dr.-Ing.**  
Institute of Physics,  
AG Wind Energy Systems – WE-Sys  
+49 441 798-5065  
martin.bitter@uni-oldenburg.de

**Böske, Lennart, M.Sc.**  
Institute of Meteorology and  
Climatology  
+49 511 762-3232  
boeske@muk.uni-hannover.de

**Bode, Matthias, M.Sc.**  
Institute for Risk and Reliability – IRZ  
bode@bauinf.uni-hannover.de

**Bohne, Tobias, M.Sc.**  
Institute of Structural Analysis  
+49 551 762-2859  
t.bohne@isd.uni-hannover.de

**Brand, Carl-Robert, M.Sc.**  
Institute of Turbomachinery and Fluid  
Dynamics +49 (0)511 762-19856  
brand@tfd.uni-hannover.de

**Brencher, Janina**  
Institute of Machine Design and Tribology  
+49 511 762 2267  
brencher@imkt.uni-hannover.de

**Bromm, Marc, M.Sc.**  
Institute of Physics,  
AG Wind Energy Systems – WE-Sys  
+49 441 798 5063  
marc.bromm@uni-oldenburg.de

**Collmann, Mareike, Dipl.-Ing.**  
Institute for Steel Construction  
+49 511 762-17211  
collmann@stahl.uni-hannover.de

**Dapperheld, Jörg**  
Institute of Physics,  
AG Turbulence, Wind Energy and  
Stochastics – TWIST  
+49 441 798 3535  
joerg.dapperheld@uni-oldenburg.de

**Decker, André, Dr.-Ing.**  
BIK – Institute for integrated Product  
Development  
+49 421 218-64874  
decker@uni-bremen.de

**Dibbern, Christoph, M.Sc.**  
Department of Computing Science  
+49 441 798-4482  
christoph.dibbern@uni-oldenburg.de

**Dollinger, Christoph, M.Sc.**  
Bremen Institute for Metrology,  
Automation and Quality Science  
(BIMAQ),  
+49 421 218 64628  
dol@bimaq.de

**Dörenkämper, Martin, M.Sc.**  
Institute of Physics,  
AG Energy Meteorology  
+49 441 798 5077  
martin.doerenkaemper@forwind.de



**Dose, Bastian, M.Sc.**

Institute of Physics,  
AG Turbulence, Wind Energy and  
Stochastics – TWiST  
+49 441 798 5056  
bastian.dose@forwind.de

**Dubois, Jan, M. Sc.**

Institute for Steel Construction  
+49 511 762-2492  
dubois@stahl.uni-hannover.de

**Droste, Rainer, M.Sc.**

Department of Computing Science  
+49 441 9722-451  
rainer.droste@uni-oldenburg.de

**Drüke, Sonja, M.Sc.**

Institute of Physics,  
AG Energy Meteorology  
Tel.: +49 441 798 5078  
sonja.drueke@forwind.de

**Ehrmann, Andreas, Dipl.-Ing.**

Institute of Structural Analysis  
+49 551 762-17213  
a.ehrmann@isd.uni-hannover.de

**Eichstädt, Rasmus, Dipl.-Ing.**

Institute for Steel Construction  
+49 511 762-5949  
eichstaedt@stahl.uni-hannover.de

**El Haoum, Sabina, Dipl.-Wirt-Inf.**

Department of Computing Science  
+49 441 798-4483  
sabina.el.haoum@uni-oldenburg.de

**Ende, Johannes, M.Sc.**

Institute of Wind Energy Systems  
+49 511 762 17659  
johannes.ende@iwes.uni-hannover.de

**Engel, Franca**

ForWind Head Office  
+49 441 798 5087  
franca.engel@forwind.de

**Ernst, Benedikt, Dipl.-Wi.-Ing.**

Institute of Turbomachinery and Fluid  
Dynamics  
+49 511 762 2734  
ernst@tfd.uni-hannover.de

**Franke, Jan, Dipl.-Ing.**

BIK – Institute for Integrated Product-  
Development  
+49 421 218 64876  
j.franke@uni-bremen.de

**Fricke, Moritz, Dipl.-Ing.**

Institute of Structural Analysis  
+49 511 762 4393  
m.fricke@isd.uni-hannover.de

**Fohchu Ning, Wisdom, B.Sc**

Institute of Physics, Oldenburg

**Fuhrmann, Martina, M.Sc.**

Bremen Institute for Metrology,  
Automation and Quality Science (BIMAQ)  
+49 421 218 64612  
fuh@bimaq.de

**Gerasch, Wolf-Jürgen, Dipl.-Ing.**

Institute of Structural Analysis  
+49 511 762 2247  
wj.gerasch@isd.uni-hannover.de

**Geuter, Jürgen, Dipl.-Inform.**

Department of Computing Science  
+49 441 798-4473  
geuter@wi-ol.de

**Goch, Gert, Prof. Dr.-Ing.**

Bremen Institute for Metrology,  
Automation and Quality Science (BIMAQ)  
+49 421 218 64600  
gg@bimaq.de

**Gollücke, Volker, M.Sc.**

Department of Computing Science  
+49 441 9722-481  
golluecke@wi-ol.de

**Gomez, Alejandro, M.Sc.**

Institut für Turbomaschinen und Fluid-  
Dynamik  
+49 511 762 5148  
gomez@tfd.uni-hannover.de

**Goretzka, Jan, M.Sc.**

Institute of Structural Analysis  
+49 511 762 4273  
j.goretzka@isd.uni-hannover.de

**Gottschalk, Malte, Dipl.-Ing.**

Institute for Steel Construction  
+49 511 762 3367  
gottschalk@stahl.uni-hannover.de

**Greve, Thomas, Dipl.-Phys.**

Institute of Physics,  
AG Turbulence, Wind Energy and  
Stochastics – TWiST  
+49 441 798 5057  
thomas.greve@uni-oldenburg.de

**Grießmann, Tanja, Dr.-Ing.**

Institute of Structural Analysis  
+49 511 762 2247  
t.griessmann@isd.uni-hannover.de

**Gülker, Gerd, Dr.**

Institute of Physics,  
AG Turbulence, Wind Energy and  
Stochastics – TWiST  
+49 441 798 3511  
gerd.guelker@uni-oldenburg.de

**Günther, Robert, M.Sc.**

Institute of Physics,  
AG Energy Meteorology  
+49 441 798 5077  
robert.guenther@forwind.de

**Haack, Frederik, B.Sc.**

Institute of Physics,  
AG Energy Meteorology  
+49 441 798 5078  
frederik.haack@forwind.de

**Hadjihosseini, Ali, M.Sc.**

Institute of Physics,  
AG Turbulence, Wind Energy and  
Stochastics – TWiST  
+49 441 798 5043  
ali.hadjihosseini@uni-oldenburg.de

**Häfele, Jan, Dipl.-Ing.**

Institute of Structural Analysis  
+49 551 762-4208  
j.haeefe@isd.uni-hannover.de

**Häckell, Moritz, Dipl.-Ing.**

Institute of Structural Analysis  
+49 511 762 4393  
m.haekell@isd.uni-hannover.de

**Hahn, Axel, Prof. Dr.-Ing.**

Department of Computing Science  
+49 441 798 4480  
hahn@wi-ol.de

**Hansen, Michael, Dr.-Ing.**

Institute of Concrete Construction  
+49 511 762 3353  
hansen@ifma.uni-hannover.de

**Haunhorst, Frauke, Dipl.Kffr.**

ForWind Head Office  
+49 441 798 5090  
frauke.haunhorst@forwind.de

**Heinemann, Detlev, Dr.**

Institute of Physics,  
AG Energy Meteorology  
+49 441 798 3543  
detlev.heinemann@forwind.de

**Heißelmann, Hendrik, Dipl.-Phys.**

Institute of Physics, AG Turbulence, Wind  
Energy and Stochastics – TWiST  
+49 441 798 3643  
hendrik.heisselmann@uni-oldenburg.de

**Herraez Hernandez, Ivan, M.Sc.**

Institute of Physics,  
AG Turbulence, Wind Energy and  
Stochastics – TWiST  
+49 441 798 5055  
ivan.herraez.hernandez@uni-oldenburg.de

**Hesseling, Christina, Dipl.-Phys.**

Institute of Physics,  
AG Turbulence, Wind Energy and  
Stochastics – TWiST  
+49 441 798 3514  
christina.hesseling@uni-oldenburg.de

**Hildebrandt, Arndt, Dipl.-Ing.**

Franzius-Institute for Hydraulic,  
Waterways and Coastal Engineering  
+49 511 762 2582  
hildebrandt@fi.uni-hannover.de

**Hinrichs, Christian, M.Sc.**

Department of Computing Science  
+49 441 798 2755  
christian.hinrichs@uni-oldenburg.de

**Hölling, Michael, Dr.**

Institute of Physics,  
AG Turbulence, Wind Energy and  
Stochastics – TWiST  
+49 441 798 3951  
michael.hoelling@uni-oldenburg.de

**Hoffmann, Felix, Dipl.-Ing.**

Institute for Electrical Drives, Power  
Electronics and Devices (IALB)  
+49 421 218 62664  
felix.hoffmann@uni-bremen.de

**Hofmann, Lutz, Prof. Dr.-Ing. habil.**

Institute of Electric Power Systems  
Tel.: +49 511 762 2801  
hofmann@iee.uni-hannover.de

**Hogreve, Sebastian, Dipl.-Ing.**

Bremen Institute for Mechanical  
Engineering (bime)  
+49 421 218 64837  
hogreve@bime.de

**Homeyer, Tim, Dipl.-Phys.**

Institute of Physics,  
AG Turbulence, Wind Energy and  
Stochastics – TWiST  
+49 441 798 3514  
tim.homeyer@uni-oldenburg.de

**Hornauer, Sascha, M.Sc.**

Department of Computing Science  
+49 441 798-4482  
sascha.hornauer@uni-oldenburg.de

**Horte, Daria, Dipl.-Ing.**

Institute of Wind Energy Systems  
+49 511 762 14190  
daria.horte@iwes.uni-hannover.de

**Hübler, Clemens, M.Sc.**

Institute of Structural Analysis– ISD  
+49 511 762 2885  
c.huebler@isd.uni-hannover.de

**Jankowski, Sophie**

Institute of Physics, Oldenburg

**Janssen, Nick, B.Sc**

Institute of Physics, Oldenburg

**Junk, Constantin, M.Sc.**

Institute of Physics,  
AG Wind Energy Systems – WE-Sys  
+49 441 798 5079  
constantin.junk@forwind.de

**Kämper, Jan-Hinrich, Dipl.-Inform.**

Department of Computing Science  
+49 441 798-4473  
kaemper@wi-ol.de

**Kärn, Moses**

ForWind Head Office  
+49 441 798 5082  
moses.kaern@forwind.de

**Kaminski, Nando, Prof. Dr.-Ing.**

Institute for Electrical Drives, Power  
Electronics and Devices (IALB)  
+49 421 218 62660  
nando.kaminski@uni-bremen.de

**Kanani-Sühring, Farah, Dipl.-Met.**

Institute of Meteorology and  
Climatology  
+49 511 762-3232  
kanani@muk.uni-hannover.de

**Kelma, Sebastian, Dipl.-Ing.**

Institute for Steel Construction  
+49 511 762-4139  
kelma@stahl.uni-hannover.de

**Keshtova, Fatima, Dipl.-Phys.**

Institute of Physics, AG Turbulence, Wind  
Energy and Stochastics – TWiST  
+49 441 798 5059  
fatima.keshtova@uni-oldenburg.de

**Kies, Alexander, M.Sc.**

Institute of Physics, Oldenburg  
+49 441 798-5078  
alexander.kies@forwind.de

**Knigge, Christoph, Dr. rer. nat.**

Institute of Meteorology and  
Climatology  
+49 511 762-2680  
knigge@muk.uni-hannover.de

**Koppaetzky, Nils, Dipl.-Phys.**

Department of Computing Science  
+49 441 9722-207  
nils.koppaetzky@uni-oldenburg.de

**Kraft, Martin, Dipl.-Ing.**

Institute of Physics,  
AG Wind Energy Systems – WE-Sys  
+49 441 798-5065  
martin.kraft@uni-oldenburg.de

**Kruse, Dennis, M.Sc.**

Bremen Institute for Metrology,  
Automation and Quality Science  
(BIMAQ),  
+49 421 218 64631  
kru@bimaq.de

**Kühn, Martin, Prof. Dr. Dipl.-Ing.**

Institute of Physics,  
AG Wind Energy Systems – WE-Sys  
+49 441 798 5061  
martin.kuehn@forwind.de

**Kuhfuss, Bernd, Prof. Dr.-Ing.**

bime Bremen  
Institute for Mechanical Engineering  
+49 421 218-64800  
Kuhfuss@bime.de

**Kuhnle, Bernd, Dipl.-Ing.**

Institute of Physics,  
AG Wind Energy Systems – WE-Sys  
+49 441 798 5064  
bernd.kuhnle@forwind.de

**Langner, Michael, Dipl.-Phys.**

Institute of Physics,  
AG Turbulence, Wind Energy and  
Stochastics – TWiST  
+49 441 798 5052  
michael.langner@uni-oldenburg.de

**Lemke, Kathrin, Dipl.-Ing.**

Institute for Geotechnical Engineering  
+49 511 762 3736  
lemke@igth.uni-hannover.de

**Lewandowski, Marco, Dipl.-Wi.-Ing.**

BIK – Institute for integrated Produkt-  
Development  
+49 421 218 50122  
lew@biba.uni-bremen.de

**Lin, Shy-Yea, M.Sc.**

Institute of Turbomachinery and Fluid  
Dynamics  
+49 (0)511 762-17871  
lin@tfd.uni-hannover.de

**Lochte-Holtgreven, Stephan, Dr.-Ing.**

Institute for Steel Construction  
+49 511 762 3712  
lochte@stahl.uni-hannover.de

**Löw, Kathrin, Dipl.-Ing.**

Institute for Steel Construction  
Tel.: +49 511 762 3540  
loew@stahl.uni-hannover.de

**Lohaus, Ludger, Univ.-Prof. Dr.-Ing.**

Institute of Building Materials Science  
(IfB)  
+49 511 762 3722  
lohaus@baustoff.uni-hannover.de

**Lohmann, Gerold, Dipl. Hydrol.**

Institute of Physics, Oldenburg  
+49 441 798-3577  
gerald.lohmann@uni-oldenburg.de

**Mauch, Raphael, M. Sc.**

Bremen Institute for Metrology,  
Automation and Quality Science (BIMAQ)  
+49 0421 218 64645  
mau@bimaq.de

**Maronga, Björn, Dr. rer. nat.**

Institute of Meteorology and Climatology  
+49 511 762-2680  
maronga@muk.uni-hannover.de

**Marx, Steffen, Univ.-Prof. Dr.-Ing.**

Institute of Concrete Construction  
+49 511 762-3352  
marx@ifma.uni-hannover.de

**Medjroubi, Wided, Dr.**

Institute of Physics, AG Turbulence, Wind  
Energy and Stochastics – TWiST  
+49 441 798 5055  
wided.medjroubi@uni-oldenburg.de

**Mehrens, Anna, M.Sc.**

Institute of Physics, Oldenburg  
+49 441 798-5079  
anna.mehrens@forwind.de

**Meints, Irene**

Wind Energy Systems  
+49 441 798-5060  
irene.meints@uni-oldenburg.de

**Mertens, Axel, Prof. Dr.-Ing.**

Institute for Drive Systems and Power  
Electronics  
+49 511 762 2471  
mertens@ial.uni-hannover.de

**Meyer zu Holte, Jan Benno, M.Sc.**

Department of Computing Science  
+49 441 9722-477  
jan.meyer.zu.holte@uni-oldenburg.de

**Milan, Patrick, M.Sc.**

Institute of Physics, AG Turbulence, Wind  
Energy and Stochastics – TWiST  
+49 441 798 5054  
patrick.milan@uni-oldenburg.de

**Mörz, Tobias, Prof. Dr.**

Center for Marine Environmental Sciences –  
MARUM  
+49 421 218 65840  
tmoerz@uni-bremen.de

**Morales, Allan, M.Sc.**

Institute of Physics,  
AG Turbulence, Wind Energy and  
Stochastics – TWiST  
+49 441 798 5054  
allanfisica@gmail.com

**Neuber, Malgorzata**

Institute of Structural Analysis  
+49 511 762 2885  
m.neuber@isd.uni-hannover.de

**Neuweiler, Insa, Prof. Dr.**

Institute of Fluid Mechanics and Environ-  
mental Physics in Civil Engineering  
+49 511 762 3567  
neuweiler@hydromech.uni-hannover.de

**Ohlendorf, Jan-Hendrik, Dipl.-Wi.-Ing.**

Product- and Process Development of  
Handling Limp Materials,  
BIK – Institute for Integrated Product  
Development  
+49 421 218 64876  
johlendorf@uni-bremen.de

**Orlik, Bernd, Prof. Dr.-Ing.**

Institute for Electrical Drives, Power Elec-  
tronics and Devices (IALB)  
+49 421 218 62680  
orlik@ialb.uni-bremen.de

**Ottink, Kathrin, Dipl.-Ing.**

Institute of Machine Design and Tribology  
+49 511 762 2267  
ottink@imkt.uni-hannover.de

**Ortega Gómez, Jaione, M.Sc.**

Institute of Wind Energy Systems  
+49 511 762 14120  
jaione.ortega@iwes.uni-hannover.de

**Pahn, Thomas, Dipl.-Ing.**

Institute of Structural Analysis  
+49 0511 762 4208  
t.pahn@isd.uni-hannover.de

**Parniak, Agnieszka, Dipl.-Ing.**

Institute of Physics,  
AG Turbulence, Wind Energy and  
Stochastics – TWiST  
+49 441 798 3535  
agnieszka.parniak@mail.uni-oldenburg.de

**Parra, Jose-Placido Viol, Eng.-Aero**

Institute of Physics,  
AG Turbulence, Wind Energy and  
Stochastics – TWiST  
+49 441 798 5055  
jose-placido.parra.viol@uni-oldenburg.de

**Pawletta, Peter**

ForWind Head Office  
+49 441 798 5087  
peter.pawletta@forwind.de

**Peinke, Joachim, Prof. Dr.**

Institute of Physics,  
AG Turbulence, Wind Energy and  
Stochastics – TWiST  
+49 441 798 3536  
peinke@uni-oldenburg.de

**Penner, Nikolai, M.Sc.**

Institute of Structural Analysis  
+49 551 762-4111  
n.penner@isd.uni-hannover.de

**Perrone, Francesco, M.Sc.**

Institute of Physics,  
AG Wind Energy SyStems – WE-Sys  
+49 441 798 5063  
francesco.perrone@uni-oldenburg.de

**Podgorski, Matt, M.Sc.**

ForWind Head Office  
+49 441 798 5093  
matt.podgorski@forwind.de

**Poland, Kathleen, Dipl.-Eng.**

Institute of Physics,  
AG Wind Energy SyStems – WE-Sys  
+49 441 798 5065  
kathleen.poland@forwind.de

**Poll, Gerhard, Prof. Dr.-Ing.**

Institute of Machine Design and Tribology  
+49 511 762 2416  
poll@imkt.uni-hannover.de

**Ponick, Bernd, Prof. Dr.-Ing.**

Institute for Drive SyStems and Power  
Electronics  
+49 511 762 2571  
ponick@ial.uni-hannover.de

**Prekel, Helmut, Dipl. Phys.**

Bremen Institute for Metrology,  
Automation and Quality Science (BIMAQ)  
+49 0421 218 64629  
pre@bimaq.de

**Puczyłowski, Jaroslaw, M.Sc.**

Institute of Physics,  
AG Turbulence, Wind Energy and  
Stochastics – TWiST  
+49 441 798 3643  
jaroslaw.puczyłowski@forwind.de

**Raba, Alexander, Dipl.-Ing.**

Institute for Steel Construction  
+49 511 762-4975  
raba@stahl.uni-hannover.de

**Rahimi, Hamid, M.Sc.**

Institute of Physics,  
AG Turbulence, Wind Energy and  
Stochastics – TWiST  
+49 441 798 5065  
hamid.rahimi@forwind.de

**Ramzan, Muhammad, M.Sc.**

Institute of Physics,  
AG Turbulence, Wind Energy and  
Stochastics – TWiST  
+49 441 798 5053  
muhammad.ramzan@uni-oldenburg.de

**Raasch, Siegfried, Prof. Dr. rer. nat.**

Institute of Meteorology and  
Climatology  
+49 511 762-3253  
raasch@muk.uni-hannover.de

**Reck, Martin, M.Sc.**

Institute of Physics,  
AG Wind Energy SyStems – WE-Sys  
+49 441 798 3560  
martin.reck@forwind.de

**Redecker, Marc Allan, Dipl.-Wi.-Ing.**

BIK – Institute for integrated Produkt-  
Development  
+49 421 218-64877 maalre@uni-bremen.de

**Reichel, Juliane, Dr.**

ForWind Head Office  
+49 441 798 5085  
juliane.reichel@forwind.de

**Reil, Benjamin, M.Sc.**

Institute of Structural Analysis  
+49 511 762 17213  
b.reil@isd.uni-hannover.de

**Reinke, Nico, Dipl.-Phys.**

Institute of Physics,  
AG Turbulence, Wind Energy and  
Stochastics – TWiST  
+49 441 798 3455  
nico.reinke@uni-oldenburg.de

**Reuter, Andreas, Prof. Dr.-Ing.**

Institute of Wind Energy Systems  
+49 511 762 4712  
andreas.reuter@iwes.uni-hannover.de

**Reuter, Rainer, Dr.**

Institute of Physics, AG Marine Physics  
+49 441 798 3522  
rainer.reuter@uni-oldenburg.de

**Rinn, Philip, Dipl.-Phys.**

Institute of Physics, AG Turbulence, Wind  
Energy and Stochastics – TWiST  
+49 441 798 5052  
Philip.rinn@uni-oldenburg.de

**Rockel, Stanislav, Dipl.-Phys.**

Institute of Physics,  
AG Turbulence, Wind Energy and  
Stochastics – TWiST  
+49 441 798 3455  
stanislav.rockel@uni-oldenburg.de

**Rolbiecki, Martin, Dipl.-Wi.-Ing.**  
Institute for Integrated Product  
Development  
+49 421 218 64875  
rolbiecki@uni-bremen.de

**Rolfes, Raimund, Prof. Dr.-Ing. habil.**  
Institute of Structural Analysis  
+49 511 762 3867  
r.rolfes@isd.uni-hannover.de

**Rott, Andreas, Dipl.-Math.**  
Institute of Physics,  
AG Wind Energy Systems – WE-Sys  
+49 441 798-5064  
andreas.rott@uni-oldenburg.de

**Rustemeier, Jörg, M.Sc.**  
Institute of Structural Analysis  
+49 511 762 2885  
j.rustemeier@isd.uni-hannover.de

**Rzeczkowski, Patrick, Dipl.-Ing.**  
Institute of Building Materials Science  
+49 511 762 3258  
p.rzeczkowski@baustoff.uni-hannover.de

**Santos Allamillos, Francisco Javier, Dr.**  
Institute of Physics, Oldenburg

**Santos, Francisco, Dr.**  
Institute of Physics,  
AG Energy Meteorology  
+49 441 798 5075  
francisco.santos@forwind.de

**Sauer, Jürgen, Prof. Dr.-Ing.**  
Department of Computing Science  
+49 441 798-4488  
juergen.sauer@uni-oldenburg.de

**Schaumann, Peter, Prof. Dr.-Ing.**  
Institute for Steel Construction  
+49 511 762 3781  
schaumann@stahl.uni-hannover.de

**Schlurmann, Torsten, Prof. Dr.-Ing.**  
Franzius-Institute for Hydraulic,  
Waterways and Coastal Engineering  
+49 511 762 19021  
schlurmann@fi.uni-hannover.de

**Schmidt, Andreas Hermann,**  
Dipl. Ing.  
ForWind / Universität Oldenburg  
+49 441 798-5096  
andreas.h.schmidt@forwind.de

**Schmidt, Boso, Dipl.-Ing.**  
Institute of Concrete Construction,  
Leibniz Universität Hannover  
+49 511 762 3355  
schmidt@ifma.uni-hannover.de

**Schmidt, Michael, Dipl.-Phys.**  
Institute of Physics,  
AG Energy Meteorology  
+49 441 798 5074  
michael.schmidt@forwind.de

**Schmoch, Arne, Dipl.-Ing.**  
Institute of Structural Analysis  
+49 551 762-4208  
a.schmoch@isd.uni-hannover.de

**Schmohl, Tim, Dipl.-Ing.**  
Institute for Integrated Product  
Development  
+49 421 218 64872  
tschmoll@uni-bremen.de

**Schmoor, Kirill, Dipl.-Ing.**  
Institute for Geotechnical Engineering,  
+49 511 762 5106  
schmoor@igth.uni-hannover.de

**Schneemann, Jörg, Dipl.-Phys.**  
Institute of Physics,  
AG Wind Energy Systems – WE-Sys  
+49 441 798 5062  
joerge.schneemann@forwind.de

**Scholle, Niklaas, Dipl.-Ing.**  
Institute of Building Materials Science  
+49 511 762 3258  
n.scholle@baustoff.uni-hannover.de

**Schröder, Christian, Dipl.-Ing.**  
Institute for Geotechnical Engineering,  
+49 511 762 4152  
schroeder@igth.uni-hannover.de

**Schröder, Karsten, Dr.**  
Institute of Structural Analysis – ISD  
+49 511 762 2885  
k.schroeder@isd.uni-hannover.de

**Schröter, Onno, Dipl.-Ing (FH), M.Eng.**  
Bremen Institute for Metrology,  
Automation and Quality Science (BI-  
MAQ),  
+49 421 218 64609  
sc@bimaq.de

**Schwarz, Christoph, Dipl.-Math.**  
Department of Computing Science  
+49 441 798-4473  
christoph.schwarz@uni-oldenburg.de

**Schyska, Bruno, M.Sc.**  
Institute of Physics, Oldenburg  
+49 441 798-5078  
bruno.schyska@forwind.de

**Sühring, Matthias, Dr. rer. nat.**  
Institute of Meteorology and Climatology  
+49 511 762-4413  
suehring@muk.uni-hannover.de

**Schwarzer, Christoph, Dipl.-Oek.**  
ForWind Head Office  
+49 441 798 5084  
christoph.schwarzer@forwind.de

**Seidel, Elke**  
ForWind Head Office  
+49 441 798 5092  
elke.seidel@forwind.de

**Segelken, Katharina, M.A.**  
ForWind Head Office  
+49 441 798 5088  
katharina.segelken@forwind.de

**Segelken, Lars**  
Institute of Physics, Oldenburg  
+49 441 798-5074  
lars.segelken@forwind.de

**Seume, Jörg, Prof. Dr.-Ing.**

Institute of Turbomachinery and Fluid Dynamics  
+49 511 762 2733  
seume@tfd.uni-hannover.de

**Sevinc, Alper, Dipl.-Ing. (FH)**

Institute of Wind Energy Systems  
+49 511 762 3944  
alper.sevinc@iwes.uni-hannover.de

**Sonnenschein, Michael, Prof. Dr.**

Department of Computing Science  
+49 441 798 2750  
michael.sonnenschein@uni-oldenburg.de

**Sorg, Michael, Dipl.-Ing.**

Bremen Institute for Metrology, Automation and Quality Science (BIMAQ)  
+49 421 218 64620  
sor@bimaq.de

**Späth, Stephan, Dipl.-Met.**

Institute of Physics, AG Energy Meteorology  
+49 441 798 5079  
stephan.spaeth@forwind.de

**Stahlmann, Arne, Dipl.-Ing.**

Franzius-Institute for Hydraulic, Waterways and Coastal Engineering  
+49 511 762 2584  
stahlmann@fi.uni-hannover.de

**Steinborn, Thomas, Dr.-Ing.**

Institute of Building Materials Science  
+49 511 762 3105  
t.steinborn@baustoff.uni-hannover.de

**Steinfeld, Gerald, Dr.**

Institute of Physics, AG Energy Meteorology & AG Turbulence, Wind Energy and Stochastics – TWiST  
+49 441 798 5073  
gerald.steinfeld@forwind.de

**Steppler, Stefanie, Dipl.-Ing.**

Institute for Steel Construction  
+49 511 762 17212  
steppler@stahl.uni-hannover.de

**Stöbener, Dirk, Dipl.-Phys.**

Bremen Institute for Metrology, Automation and Quality Science (BIMAQ),  
+49 421 218 64640  
std@bimaq.de

**Stoffels, Nicole, Dipl.-Met.**

Institute of Physics, AG Energy Meteorology  
+49 441 798 5079  
nicole.stoffels@forwind.de

**Stübig, Cornelia, Dipl.-Ing.**

Institute for Drive SyStems and Power Electronics  
+49 511 762 2874  
stuebig@ial.uni-hannover.de

**Stütz, Elisabeth, Mag.**

Institute of Physics, AG Energy Meteorology  
+49 441 798 5077  
elisabeth.stuetz@forwind.de

**Surm, Hendrik, M.Sc.**

Department of Computing Science  
+49 441 9722-207  
henrik.surm@uni-oldenburg.de

**Tambke, Jens, Dipl.-Phys.**

Institute of Physics, AG Energy Meteorology  
+49 441 798 5072  
jens.tambke@forwind.de

**Terceros, Mauricio, M.Sc.**

Institute for Geotechnical Engineering  
+49 511 762 3998  
terceros@igth.uni-hannover.de

**Tegeler, Sebastian, Dipl.-Ing.**

Institute for Drive SyStems and Power Electronics  
+49 511 762 2891  
tegeler@ial.uni-hannover.de

**Thieken, Klaus, Dipl.-Ing.**

Institute for Geotechnical Engineering  
+49 511 762 4153  
thieken@igth.uni-hannover.de

**Thiemann, Philipp, M.Sc.**

Bremen Institute for Metrology, Automation and Quality Science (BIMAQ),  
+49 421 218 64664  
thi@bimaq.de

**Thoben, Klaus-Dieter, Prof. Dr.-Ing. habil.**

BIK – Institute for Integrated Product Development  
+49 421 218 50005  
tho@biba.uni-bremen.de

**Tipping, Melanie**

ForWind Head Office  
+49 441 798 5083  
melanie.tipping@forwind.de

**Tomann, Christoph, Dipl.-Ing.**

Institute of Building Materials Science  
+49 511 762 4206  
c.tomann@baustoff.uni-hannover.de

**Trabucchi, Davide, M.Sc.**

Institute of Physics, AG Wind Energy SyStems – WE-Sys  
+49 441 798 5062  
davide.trabucchi@forwind.de

**Tracht, Kirsten, Prof. Dr.Ing.**

Bremen Institute for Mechanical Engineering  
+49 421 218 64841  
tracht@bime.de

**Traphan, Dominik, Dipl.-Phys.**

Institute of Physics, AG Turbulence, Wind Energy and Stochastics – TWiST  
+49 441 7983 514  
dominik.traphan@uni-oldenburg.de

**Trujillo, Juan José, M.Sc.**

Institute of Physics, AG Wind Energy SyStems – WE-Sys:  
+49 441 798 5062  
juan.trujillo@forwind.de

**Tsiapoki, Stavroula, Dipl.-Ing.**

Institute of Structural Analysis  
+49 551 762-8063  
s.tsiapoki@isd.uni-hannover.de

**Ungurán, Robert, Dipl.-Ing.**

Institute of Physics,  
AG Wind Energy SyStems – WE-Sys  
+49 441 798 5064  
robert.unguran@forwind.de

**Vali, Mehdi, M. Sc.**

Institute of Physics,  
AG Wind Energy SyStems – WE-Sys  
+49 441 798-5063  
mehdi.vali@uni-oldenburg.de

**Vera-Tudela Carreno, Luis Enrique, M.Sc.**

Institute of Physics,  
AG Wind Energy SyStems – WE-Sys  
+49 441 798 5063  
luis.vera.tudela@forwind.de

**Völker, Thorsten, Dr.-Ing.**

Institute for Electrical Drives, Power  
Electronics and Devices (IALB)  
+49 421 218 62698  
voelker@ialb.uni-bremen.de

**Vogel, Ute, Dr.**

Department for Computing Science  
+49 441 798 2752  
ute.vogel@informatik.uni-oldenburg.de

**Vollmer, Lukas, M.Sc.**

Institute of Physics, Oldenburg  
+49 441 798-5077  
lukas.vollmer@forwind.de

**von Bremen, Lueder, Dr.**

Institute of Physics,  
AG Energy Meteorology  
+49 441 798 5071  
lueder.von.bremen@forwind.de

**von der Haar, Christoph, Dipl.-Ing.**

Institute of Concrete Construction,  
Leibniz Universität Hannover  
+49 511 762 17461  
vonderhaar@ifma.uni-hannover.de

**Vorspel, Lena, M.Sc.**

Institute of Physics,  
AG Turbulence, Wind  
Energy and Stochastics – TWiST  
+49 441 798 5056  
lena.vorspel@uni-oldenburg.de

**Voss, Stephan M.Sc.**

Institute of Physics,  
AG Wind Energy SyStems – WE-Sys  
+49 441 798 5065  
stephan.voss@uni-oldenburg.de

**Wächter, Matthias, Dr.**

Institute of Physics, AG Turbulence, Wind  
Energy and Stochastics – TWiST  
+49 441 798 5051  
matthias.waechter@uni-oldenburg.de

**Weicken, Hannes, Dipl.-Ing.**

Institute of Building Materials Science  
+49 511 762 8966  
h.weicken@baustoff.uni-hannover.de

**Wermke, Corinna, Dipl.-Sozialwiss.**

ForWind Head Office  
+49 441 798 5086  
corinna.wermke@forwind.de

**Werner, Michael, Dipl.-Ing.**

Institute of Building Materials Science  
+49 511 762 3477  
m.werner@baustoff.uni-hannover.de

**Westerkamp, Jan F., Dipl.-Ing.**

Bremen Institute for Metrology,  
Automation and Quality Science (BIMAQ)  
+49 421 218 64609  
wes@bimaq.de

**Wilms, Mayumi, Dipl.-Ing.**

Franzius-Institute for Hydraulic,  
Waterways and Coastal Engineering  
+49 511 762 5179  
wilms@fi.uni-hannover.de

**Winstroth, Jan, Dipl.-Ing.**

Institute of Turbomachinery and Fluid  
Dynamics  
+49 511 762 8925  
winstroth@tfd.uni-hannover.de

**Witha, Björn, Dipl.-Met.**

Institute of Physics,  
AG Energy Meteorology  
+49 441 798 5075  
bjoern.witha@forwind.de

**Wöhrmann, Michael, Dipl.-Ing.**

Institute for Drive SyStems and Power  
Electronics  
+49 511 762 3770  
woehrmann@ial.uni-hannover.de

**Wolff, Miriam, Dipl.-Inform.**

AG Energy Meteorology  
+49 441 798 5092  
miriam.wolff@forwind.de

**Wolff, Thorben, Dipl.-Ing.**

Institute of Turbomachinery and Fluid  
Dynamics +49 (0)511 762-17865  
wolff@tfd.uni-hannover.de

**Wurps, Hauke, M.Sc.**

Institute of Physics, Oldenburg  
+49 441 798-5074  
hauke.wurps@forwind.de

**Zack, Charis**

ForWind Head Office  
+49 441 798 5081  
charis.zack@forwind.de

**Zadorozhnyy, Andre, Dipl.-Ing.**

Institute of Physics, Oldenburg

**Zielke, Werner, Prof.em.Dr.-Ing., Dr.h.c.**

Institute of Fluid Mechanics and Environ-  
mental Physics in Civil Engineering  
+49 511 762 4294 or 3568  
zielke@hydromech.uni-hannover.de

**Zorn, Christian, Dipl.-Ing.**

Institute for Electrical Drives, Power  
Electronics and Devices (IALB)  
+49 421 218 62669  
czorn@uni-bremen.de

## Imprint

### **Publisher**

ForWind –  
Center for Wind Energy Research of the  
Universities of Oldenburg, Hannover and  
Bremen

### **Executive Board**

Prof. Dr.-Ing. Bernd Orlik  
Prof. Dr.-Ing. habil. Raimund Rolfes  
Prof. Dr.-Ing. Klaus Dieter Thoben  
Prof. Dr. Martin Kühn  
Prof. Dr. Joachim Peinke  
Prof. Dr.-Ing. Peter Schaumann

### **Address**

Ammerländer Heerstraße 136  
26129 Oldenburg  
Germany

Phone: +49 441 798-5090

Fax: +49 441 798-5099

[info@forwind.de](mailto:info@forwind.de)

[www.forwind.de](http://www.forwind.de)

### **Editorial Coordination**

Dr. Stephan Barth  
Elke Seidel

### **Photos**

ForWind

### **Layout**

Dagmar Weinreich-Brunner